

(19) World Intellectual Property Organization  
International Bureau



(43) International Publication Date  
25 March 2010 (25.03.2010)

(10) International Publication Number  
**WO 2010/032235 A1**

(51) International Patent Classification:  
A61B 18/18 (2006.01)

60850 Shoham (IL). VAYNBERG, Boris [IL/IL]; 48  
Bareket Street, 30900 Zichron Yaakov (IL).

(21) International Application Number:  
PCT/IL2009/000817

(74) Agent: BRONSTEIN, Rafi; Daltan Consulting Ltd., P.O.  
Box 1146, 44110 Kefar Sava (IL).

(22) International Filing Date:  
20 August 2009 (20.08.2009)

(81) Designated States (unless otherwise indicated, for every  
kind of national protection available): AE, AG, AL, AM,  
AO, AT, AU, AZ, BA, BB, BG, BH, BR, BW, BY, BZ,  
CA, CH, CL, CN, CO, CR, CU, CZ, DE, DK, DM, DO,  
DZ, EC, EE, EG, ES, FI, GB, GD, GE, GH, GM, GT,  
HN, HR, HU, ID, IL, IN, IS, JP, KE, KG, KM, KN, KP,  
KR, KZ, LA, LC, LK, LR, LS, LT, LU, LY, MA, MD,  
ME, MG, MK, MN, MW, MX, MY, MZ, NA, NG, NI,  
NO, NZ, OM, PE, PG, PH, PL, PT, RO, RS, RU, SC, SD,  
SE, SG, SK, SL, SM, ST, SV, SY, TJ, TM, TN, TR, TT,  
TZ, UA, UG, US, UZ, VC, VN, ZA, ZM, ZW.

(25) Filing Language: English

(26) Publication Language: English

(30) Priority Data:  
61/098,774 21 September 2008 (21.09.2008) US  
61/180,901 25 May 2009 (25.05.2009) US

(71) Applicant (for all designated States except US):  
SYNERON MEDICAL LTD. [IL/IL]; Industrial Zone,  
Tavor Building, P.O. Box 550, 20692 Yoqneam Illit (IL).

(72) Inventors; and

(75) Inventors/Applicants (for US only): ECKHOUSE, Shi-  
mon [IL/IL]; 55 Hague Street, 34980 Haifa (IL). KUT-  
SHER, Tuvia Dror [IL/IL]; 79B Hamacabeem Street,

(84) Designated States (unless otherwise indicated, for every  
kind of regional protection available): ARIPO (BW, GH,  
GM, KE, LS, MW, MZ, NA, SD, SL, SZ, TZ, UG, ZM,  
ZW), Eurasian (AM, AZ, BY, KG, KZ, MD, RU, TJ,  
TM), European (AT, BE, BG, CH, CY, CZ, DE, DK, EE,

[Continued on next page]

(54) Title: A METHOD AND APPARATUS FOR PERSONAL SKIN TREATMENT

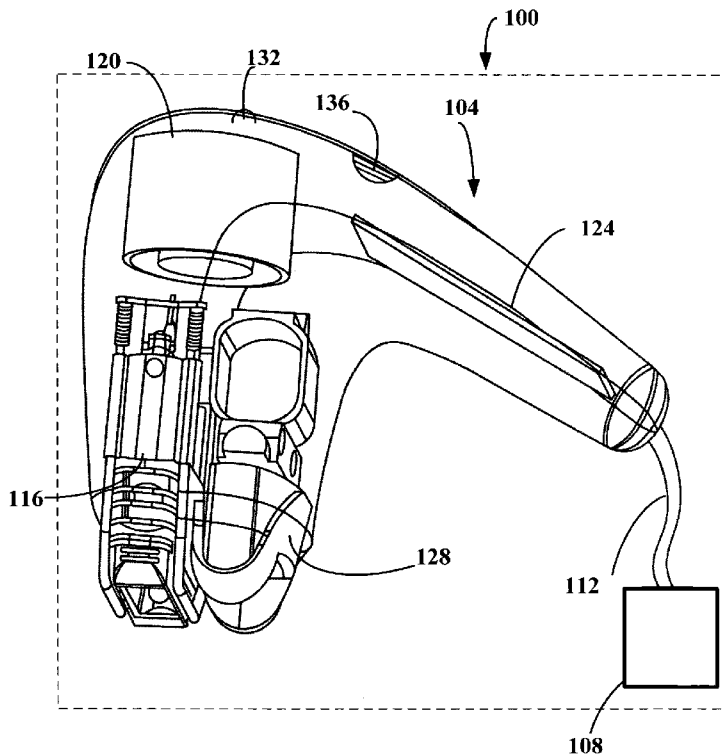

FIG. 1

(57) Abstract: Disclosed is a skin treatment  
device for personal use. The device includes  
an optical radiation providing module operat-  
ing in pulsed or continuous operation mode, a  
mechanism for continuously displacing the  
device across the skin, and a device displacement  
speed monitoring arrangement. When the de-  
vice is applied to skin, the optical pulses rep-  
etition rate establishes the power of the optical  
radiation as a function of the device displace-  
ment speed. The device a hair removal mech-  
anism configured to mechanically remove hair  
from the treated segment of the skin.

WO 2010/032235 A1

ES, FI, FR, GB, GR, HR, HU, IE, IS, IT, LT, LU, LV,  
MC, MK, MT, NL, NO, PL, PT, RO, SE, SI, SK, SM,  
TR), OAPI (BF, BJ, CF, CG, CI, CM, GA, GN, GQ, GW,  
ML, MR, NE, SN, TD, TG).

**Published:**

- *with international search report (Art. 21(3))*
- *with amended claims (Art. 19(1))*

**Declarations under Rule 4.17:**

- *of inventorship (Rule 4.17(iv))*

## A METHOD AND APPARATUS FOR PERSONAL SKIN TREATMENT

## TECHNOLOGY FIELD

[001] The present method and apparatus relate in general to the field of skin treatment and in particular to hair removal.

## [002] BACKGROUND

[003] External appearance is important to practically every person. In recent years, methods and apparatuses have been developed for different cosmetic and dermatological treatments. Among these are hair removal, treatment of vascular lesions, wrinkle removal, skin rejuvenation and others. In some of these treatments, the skin surface is illuminated to heat deeper skin or tissue volumes to a sufficiently high temperature as to achieve a desired effect, which is typically in the range of 38-60 degrees Celsius. The effect may be weakening of the hair shaft or even hair follicle or root destruction.

[004] Another desired effect may be hair re-growth retardation, which is typically achieved by illumination of earlier depilated skin surface by laser, LED, Xenon lamp, Intense Pulsed Light (IPL), or incandescent lamp radiation, generally termed optical radiation. The optical radiation may have a single wavelength for example, lasers, or several wavelengths, or a broad band spectrum. The wavelengths are selected to be optimal for the color of the contrasted component of the treated skin segment, and are typically in the range of 400 to 1800 nm. The optical radiation, usually flashing or pulsed light, is applied to the skin with the help of an applicator having an aperture of a given dimension. In order to "cover" the entire skin surface, the aperture has to be moved from place to place, in a relatively accurate fashion on a step equal to at least one aperture dimension, so that no areas of the skin will be missed or treated twice. In order to avoid this, the individual visually tracks applicator location. The light pulses inevitably reach his/her eyes, disturb the

individual, and affect the applicator location tracking and hair removal process. These devices achieve the desired effect only if a certain energy density is applied to the skin tissue. If the device is moved too quick or too slow across the skin, the device may be less efficacious or cause burns, respectively.

[005] Concurrently a number of Radio Frequency (RF) to skin application based methods for treatment of deeper skin or tissue layers have been developed. In these methods, electrodes are applied to the skin and an RF voltage in pulse or continuous waveform (CW) is applied across the electrodes. The properties of the RF voltage are selected to generate RF induced current in a volume or layer of tissue to be treated. The current heats the tissue to the required temperature, which is typically in the range of 38-60 degrees Celsius. The temperature destroys or injures the hair follicle or root and delays further hair grows.

[006] Equipment that combines light and RF treatment exists. Usually this equipment is configured to illuminate a defined segment of a subject skin generally similar or equal to the surface of the aperture through which optical radiation is directed to the skin segment. The electrodes are typically located proximal to the periphery of the aperture and the RF typically may heat deeper tissue layers than those heated by light thus destroying/injuring hair bulbs and/or hair follicle. There is a delicate relation between the amount of RF energy and optical radiation applied to the same skin segment. Exceeding the optimal proportion between them leads to skin burns, whereas application of lower than optimal proportion RF energy and optical radiation does not bring the desired treatment results.

[007] There is a need on the market for a small size, low cost, and safe to use apparatus that may be operated by the user enabling him/her to

- i) avoid skin burns or non sufficient skin treatment results.
- ii) avoid tediously looking at the treated area, during the course of treatment.

#### BRIEF SUMMARY

[008] A skin treatment device for personal use for skin treatment and hair removal. The device includes an optical radiation providing module operating in pulsed or

continuous operation mode, a hair removal mechanism, and a mechanism for continuously displacing the device across the skin. The hair removal mechanism may be a mechanical device and the mechanism for continuously displacing the device across the skin may be an optional mechanism. The user applies the device to the skin, operates the hair removal mechanism and optical radiation module and displaces the device manually or with the help of a built-in displacement mechanism across the skin segment to be treated. An optional displacement speed monitoring arrangement monitors the displacement speed and establishes the optical power as a function of the device displacement speed.

#### BRIEF LIST OF DRAWINGS

- [009] The apparatus and the method are particularly pointed out and distinctly claimed in the concluding portion of the specification. The apparatus and the method, however, both as to organization and method of operation, may best be understood by reference to the following detailed description when read with the accompanying drawings, in which like reference characters refer to the same parts throughout the different views. The drawings are not necessarily to scale, emphasis instead being placed upon illustrating the principles of the method.
- [0010] FIG. 1 is a schematic illustration of an exemplary embodiment of the apparatus for personal use for hair removal.
- [0011] FIG. 2 is a schematic illustration of an exemplary embodiment of the infrastructure assembly of the applicator or device for personal use for hair removal.
- [0012] FIG. 3 is a schematic illustration of an exemplary embodiment of the infrastructure assembly shown without the hair removal mechanism.
- [0013] FIG. 4 is a schematic illustration of an exemplary embodiment of the reflector of the optical radiation providing module and its cooling method.
- [0014] FIG. 5A is a schematic illustration of an exemplary embodiment of the device displacement mechanism.

[0015] FIG. 5B is a schematic illustration of another exemplary embodiment of the device displacement mechanism.

[0016] FIG. 5C is a schematic illustration of an additional exemplary embodiment of the device displacement mechanism.

[0017] FIG. 6 is a schematic illustration of an exemplary embodiment of the device displacement speed sensing mechanism.

[0018] FIG. 7 is a schematic illustration of an exemplary embodiment of the electrodes of the device for personal use for hair removal.

[0019] FIG. 8 is a schematic illustration of an exemplary disposable and exchangeable skin rejuvenation device for use with the present apparatus.

[0020] FIG. 9 is a schematic illustration of another exemplary method of skin treatment using the present device and apparatus.

[0021] FIG. 10 is a schematic illustration of a cross section of another exemplary embodiment of the optical radiation providing module and its cooling method.

[0022] FIG. 11 is a schematic illustration of an additional exemplary embodiment of the optical radiation providing module and its cooling method.

#### DETAILED DESCRIPTION OF EXEMPLARY EMBODIMENTS

[0023] In the following detailed description, reference is made to the accompanying drawings that form a part hereof. This is shown by way of illustration of different embodiments in which the apparatus and method may be practiced. Because components of embodiments of the present apparatus can be in several different orientations, the directional terminology is used for purposes of illustration and is in no way limiting. It is to be understood that other embodiments may be utilized, and structural or logical changes may be made without departing from the scope of the present method and apparatus. The following detailed description, therefore, is not to be taken in a limiting sense, and the scope of the present apparatus and method is defined by the appended claims.

[0024] As used herein, the term "skin treatment" includes hair removal and treatment of various skin layers such as stratum corneum, dermis, epidermis, skin

rejuvenation procedures, wrinkle removal, and such procedures as collagen shrinking or destruction.

[0025] The term "skin surface" relates to the most external skin layer, which may be stratum corneum.

[0026] Reference is made to FIG 1, which is a schematic illustration of an exemplary embodiment of the apparatus for personal skin treatment. Apparatus 100 includes an applicator or device 104 adapted for sliding movement on a subject skin; a base 108 comprising a controller, power supply module and a charge storage mechanism, such as a capacitor (not shown), where the power supply may include a transformer with or without current rectifier, and an umbilical cord 112 connecting between applicator 104 and base 108. Apparatus 100 may receive power supply from a regular electric supply network receptacle, or from a rechargeable or conventional battery. Applicator or device 104 is designed as a convenient to hold body (shown as having a transparent envelop) incorporating infrastructure 116, cooling means such as axial fan or blower 120, control circuit 124 controlling the operation of apparatus 100, and hair removal mechanism 128 attached to infrastructure frame 116 or assembled on a common frame. Hair removal mechanism 128 may be one of a group of a shaver head, a plucking or tweezing epilator like head, or razor. Head 128 may be a detachable head. For safety reasons head 128 electric contacts may be configured to activate electricity supply to hair removal mechanism only when it is inserted in the appropriate location. In an additional embodiment, hair removal mechanism may be replaced by a skin rejuvenation head (FIG. 8).

[0027] At least one visual status indicator 132 such as a LED informing or signifying user on the operational status of apparatus and/or skin treatment process parameters is attached to device 104. At least one optional audio status indicator 136 such as a buzzer signaling to the user the status of skin treatment process parameters is also attached to device 104 or located in base 108.

[0028] FIG. 2 is a schematic illustration of an exemplary embodiment of the infrastructure assembly of the applicator or device for personal skin treatment. Mounted on the infrastructure 116 are an optical radiation providing module 200, a

mechanism or arrangement shown in FIGS. 5A – 5C for continuously displacing device 104 across the skin, a displacement speed monitoring mechanism (FIG. 5A), and a safety switch (FIG. 3) mounted on the infrastructure frame 116 (FIG. 1) and activated by the radiation providing module 200 (FIG. 2). Hair removal mechanism 128 operatively configured to mechanically remove hair from the treated or target segment of the skin, is attached to infrastructure frame 116. Optionally, a pair of electrodes 220 may be attached to infrastructure frame 116.

[0029] FIG. 3 is a schematic illustration of an exemplary embodiment of the infrastructure frame 116 assembly shown without the hair removal mechanism 128 (FIG. 1). It illustrates a safety switch 300 mounted on infrastructure frame 116 and device 104 displacement direction sensor 528 shown in FIG. 5A. Insertion of radiation providing module 200 (FIG. 2), into its location in frame 116 activates safety switch 300. This prevents idle or erroneous operation of module 200. For example no high voltages will be present and “alive” in the electrodes of the applicator 104 so that no one is subject to high voltage danger if the disposable cartridge is removed.

[0030] According to some embodiments of the disclosure, an RFID device is connected to control circuit 124 (FIG. 1). The RFID device is preloaded with a maximal number of pulses to be emitted before the radiation providing module 200 has to be replaced and decreases the count with every emitted pulse. Alternatively, the RFID device is preloaded with a total energy that may be applied to the skin in a single treatment before the radiation providing module 200 (FIG. 2) has to be replaced. The RFID device may also serve as an additional safety measure, where the control circuit 124 prevents the radiation providing module 200 from emitting pulses if the RFID is not identified, namely the radiation providing module 200 has not been installed correctly.

[0031] In an additional embodiment, a 1024 Bit 1-Wire EEPROM such as DS2431 commercially available from Maxim/Dallas Semiconductors, Inc., Sunnyvale, CA 94086 U.S.A. 1-Wire EEPROM operating as a counter can be assembled on the control printed circuit 124 that among others controls the radiation providing module 200. Similar to the RFID the counter may be pre-loaded with the desired

information. The same 1-Wire EEPROM may function for radiation providing module 200 authenticity identification.

[0032] FIG 4 is a schematic illustration of an exemplary embodiment of the reflector of the optical radiation-providing module and its cooling method. Module 200 is implemented as a disposable cartridge including a source of optical radiation 400, a reflector 404 configured to reflect the emitted optical radiation to the segment of the skin to be treated, and a dielectric coated protective window 408. Window 408 defines the aperture through which the optical radiation is emitted to the skin. The source of optical radiation 400, shown in broken lines, may be an incandescent lamp such as AGAC 4627 high power density Xenon flash lamp commercially available from PerkinElmer Optoelectronics Wenzel-Jaksch Str. 31 65199 Wiesbaden, Germany or any one of a group of LED, laser diode, solid state laser, a gas laser, or a Xenon IPL (Intense Pulsed Light) lamp.

[0033] Reflector 404 is a prismatic case or body with flat facets and polygonal cross section or a tubular case or body with an optional curvature of second or higher power. It may be a simple round cylinder cross section, a parabolic cross section or any other cross section allowing the optical radiation to be concentrated and distributed uniformly across the aperture of window 408 through which the optical radiation is emitted to the skin. The dielectric coating of window 408 is selected such as to transmit the relevant sections of optical radiation spectrum to the treated segment of the skin and reflect the other. Reflector 404 has openings 412 allowing air passage inside the reflector. Openings 412 are located about the apex of reflector 404. The dielectric coated protective window 408 located adjacent or attached to the open longitudinal section of reflector 404 forms with the reflector 404 an air-conducting channel 420 bound on one side by reflector 404 and on the other side by window 408. A part of the stream of cooling air 424 generated by a cooling element such as an axial fan 120 (FIG 1) enters channel 420 through openings 412. It is directed into the air-conducting channel 420 along the source of optical radiation 400 shown in broken lines and cools it. Butt end openings 428 of reflector 404 terminate air-conducting channel on both of its ends and serve as

cooling air exhaust openings. The area of openings air exhaust openings 428 is at least equal or larger to the area of openings

412 allowing air passage into inner part of reflector 404 and air conducting channel 420. The other part of cooling air stream 424 flows around the external section of reflector 404 and cools the outer section of reflector 404.

[0034] According to some embodiments of the disclosure, as depicted schematically in FIG 10, the cooling means comprise a rotary blower 1000. Blower 1000 blows air shown by arrows 1010 into one side of the optical radiation providing module 200 (FIG. 2), where the air flows in parallel (along) to the source of optical radiation 400 and the reflector 404 (FIG. 4) and emerges from the opposite side as shown by arrows 1020 of the optical radiation providing module 200.

[0035] According to some embodiments of the disclosure, as also depicted schematically in FIG. 10, a second glass window 1030 is installed in parallel to window 408 and part of the cooling air blown by the blower 1000 and marked by arrow 1040 flows between the two windows 408 and 1030. A slanted lamp electrode 1100, as shown in FIG 11, may be installed on the air intake side of the optical radiation source 400, to enhance air flow in the direction of the windows. Arrows 1130 schematically illustrate the cooling air flow inside and outside reflector 404 and between the windows 408 and 1030. Reflector 404 is shown in FIG. 11 as a prismatic structure.

[0036] According to some embodiments of the disclosure, a fan 120, as depicted in FIG 1, may also be used to cool the air between the two glass windows. It was experimentally proven that three or more windows parallel to window 408 with cooling air flow between them provide a good thermal isolation and the part of the device being in contact with the skin almost does not change its temperature.

[0037] According to some embodiments of the disclosure, a thermal sensor 1050, such as a thermistor, or any other type of temperature measuring means may be installed on either the inflow or the outflow end of the cooling air, as a safeguard against overheating in case of malfunction of the cooling means.

[0038] Windows 408 and 1030 may be made of pyrex, sapphire, quartz, or specially treated borosilicate glass. Window 1030 or both windows may be coated with a

dielectric coating serving as a filter for reflecting back undesired wave lengths, such as UV and certain IR wavelengths, emitted from the optical radiation source 400.

[0039] According to some embodiments of the disclosure, as also shown in FIG. 11, two reflectors (1110, 1120) may be mounted between the two windows (1030, 408), on both sides thereof, to prevent light scattering outside the treatment area.

[0040] The architecture of optical radiation providing module 200 and method of cooling it allows a compact and effective optical radiation source to be produced and provide sufficient power for skin treatment. Module 200 may operate in pulsed or continuous operation mode. It is known that low repetition rate optical radiation or light pulses are annoying the user who may be constantly visually tracking the applicator location. In order to ease the user's sensation, the optical radiation source may emit a number of low power light pulses interleaved between high power treatment pulses, increasing the repetition rate of the light pulses and alleviating the annoying and eye disturbing effects of low repetition rate light pulses.

[0041] FIG. 5A is a schematic illustration of an exemplary embodiment of the device displacement mechanism. It illustrates a bottom view of an exemplary mechanism for continuously displacing device 104 across the skin. The mechanism includes a DC motor 500 of suitable size and power coupled by means of one or more gears 504 to one or more drive wheels 508 or a caterpillar type track. The user attaches device 104 to the skin 512 (FIG. 5B) and applies minimal force preventing the device from falling off the skin. Device 104 may have additional auxiliary wheels 516 in any proper amount, as required. Operation of DC motor 500 allows displacing device 104 across skin 512 with variable speed. A wheel or roller 528 of a known diameter is in contact with the skin. The roller 528 rotates as the device moves. Measuring the rotation speed of roller 528 makes it possible to determine the device displacement speed by methods known to those skilled in the art. Alternatively, one of the wheels 508 or 516 may have a known diameter.

[0042] In another exemplary embodiment of the device displacement mechanism shown in FIG. 5B a peristaltic piezoceramic motor 516 implemented as a

caterpillar type track displaces device 104 across the skin 512 as illustrated by arrow 540. In still an additional exemplary embodiment of the device displacement mechanism illustrated in FIG. 5C a belt 520 driven by a piezoceramic motor 524 or other type of motor displaces device 104 across the skin 512 as shown by arrow 544.

[0043] The device displacement mechanisms described above allow displacing device 104 with variable speed to be adapted to different skin treatment conditions. This however requires ability of sensing or monitoring and correcting the device displacement speed. FIG. 6 is a schematic illustration of an exemplary embodiment of the device displacement speed and displacement direction sensing arrangement. Device 104 (FIG. 1 and 5) displacement speed monitoring arrangement 600 may be a rotating wheel 602 or roller of known diameter being in permanent contact with skin 512. Wheel 602 may have an O-ring 604 tensioned on the periphery of wheel 602. Displacement speed monitoring arrangement 600 may be implemented as a wheel 602-I (FIG. 6B) with openings 606 and located between a LED 608 with a detector 612 configured to generate pulses when an opening passes between them. Alternatively, the wheel may be connected to a speed measurement device for example, such as a tachometer being in communication with control circuit 124. According to the speed-readings, control circuit 124 (FIG. 1) may change the displacement speed of device 104. In an alternative embodiment, an arrangement similar to an optical mouse monitors device 104 displacement speed.

[0044] Continuous sensing of the device displacement speed or velocity and direction of advance, coupled with visual or audio signals informing the user on the status of the treatment, releases the user from the annoying task of constantly tracking the applicator location visually. The user still has to ascertain that applicator displacement velocity is in accordance to the desired applicator velocity related to at least the radiation source pulse repeat rate and the active size of the aperture. The visual signal indicator and audio signal indicator provide the user the information necessary for deciding on the skin treatment status, and the user is free from memorizing the location of the previously treated strip or strips.

[0045] Direction displacement sensor may be a wheel 528 (FIG. 5) that may have asymmetric openings 614 and a LED 608 with a detector 612 configured to generate pulses when an opening passes between them. Alternatively, one of the wheels 508 or 516 may have asymmetric openings. Depending on the displacement direction the pulses caused by modulation of LED radiation by the openings 612 will have a different rise time, indicating on the displacement direction. When treatment of the skin segment is completed the operator changes the displacement direction of the applicator.

[0046] FIG 7 is a schematic illustration of an exemplary embodiment of the electrodes of the hair removal device for personal use. Skin treatment device 104 optionally includes a pair of optionally detachable electrodes 220 (FIG. 2) operatively configured to apply RF energy to a segment of the skin. RF electrodes 220 have an elongated body arranged along at least one side of protective window or aperture 408 (FIG. 4). RF electrodes 220 are suspended on springs 700 with respect to infrastructure frame 116. Alternatively, electrodes 220 may comprise solid metal strips 710 attached to the external side of the optical radiation providing module 200 housing. Metal coating deposited on suitable, may be even plastic, surfaces of module 200 may also serve as electrodes 220. During skin treatment RF electrodes 220 are in permanent contact with skin and accurately follow the skin topography. RF electrodes 220 or 710 may have a bare metal surface and be in conductive coupling with the skin, or may be dielectric coated electrodes and be in capacitive coupling with the skin.

[0047] FIG 8 illustrates an exemplary disposable and exchangeable skin rejuvenation device for use with the present apparatus. Device 800 may be mounted instead of hair removal mechanism 128. Device 800 is a cylindrical or other three-dimensional shape carrier 802 on the surface of which are dome shaped conductive elements 804 configured such that domes 804 protrude from external surface 812 of the carrier 802. Carrier 802 may be produced by stretching a flexible substrate over a carcass. This may be a solid cylinder or a squirrel cage type structure. Sides 816 of carrier 802 may bear contact strips 820 through which RF voltage can be supplied to domes 804. Such configuration of the carrier allows applying and

translating it over relatively large segments of the skin. In the context of the present disclosure, "large segment of skin" signifies a segment of skin dimensions which exceed the dimensions of the surface of the carrier, or circumference of the surface of the contact electrode or electrodes carrier. Carrier 802 has a rotational symmetry and can be easily repositioned for treatment of a neighboring skin segment by rolling it on the skin, thus providing a reasonable time for thermal relaxation of the skin segment treated earlier, and returned back to the same skin segment treated previously. The repositioning of the carrier does not leave segments or patches of the skin that were not treated and eliminates the residual patchwork type skin pattern. This type of skin treatment actually represents a continuous skin surface treatment process. Carrier 802 may be a reusable or disposable part.

[0048] FIG. 9 is a schematic illustration of an exemplary method of skin treatment using the present device and apparatus. For skin treatment, device 104 is applied to a segment of skin 900 to be treated, enabling permanent or at least mostly permanent contact between the RF electrodes 220 (FIG. 2) and the skin. Optical radiation providing module 200 is activated, and the mechanism for continuously displacing the device across the skin displaces device 104 in a desired direction, for example, along the segment of the skin to be treated. In one embodiment, optical radiation is directed through aperture 408 to irradiate a segment of skin to be treated by a constant optical radiation power, supplied in continuous or pulsed mode, and displacement speed monitoring arrangement 600 (FIG. 6) sets a proper displacement speed. The displacement speed - optical radiation power dependence may be prepared and loaded as a look-up-table (LUT) into control circuit 124. As the treatment progresses and device 104 advances across the skin, it reaches the border of the skin segment to be treated. As device 104 reaches the end of the treated or shaved skin segment, the user manually repositions device 104 on the next segment of skin to be treated or on another non-treated segment of the skin and sets it for displacement into the same or opposite direction. The danger of causing skin burns by treating the same segment of skin twice is reduced, since there is some time for the skin to cool down between successive skin treatments by

device 104. Optical radiation retards future hair growth on the treated segment of the skin by heating hair follicle. RF energy applied to the same skin segment heats deeper skin layers where hair bulbs and follicles are located, and the heat generated by the RF energy destroys them, enhancing the hair removal process performed by the optical radiation.

[0049] In an additional exemplary method of skin treatment using the present device and apparatus, the user applies the skin treatment device 104 to a skin segment from which hair has to be removed. The hair is removed from the skin segment by mechanical means, for example by shaving it or plucking it. Following mechanical hair removal, optical radiation of proper power and wavelength is applied to the same segment of skin that was treated. Optionally, RF energy may be applied to the same segment of skin. Application of optical radiation and RF energy retards further hair growth and removes hair residuals left after mechanical hair removal from the treated skin segment. Similar to the earlier disclosed method the device treating the skin segment displaces itself automatically from a treated skin segment to another untreated skin segment.

[0050] A number of embodiments have been described. Nevertheless, it will be understood that various modifications may be made without departing from the spirit and scope of the method. Accordingly, other embodiments are within the scope of the following claims:

What is claimed is:

1. A skin treatment device for personal use, said device comprising:
  - an optical radiation providing module operating in pulsed or continuous operation mode; and
  - a mechanism for continuously displacing the device across the skin.
2. The skin treatment device according to claim 1 further comprising a hair removal mechanism operatively configured to mechanically remove hair from the target segment of the skin.
3. The skin treatment device according to claim 2 wherein the hair removal mechanism is at least one of a group of a shaver, an epilator, and a razor.
4. The skin treatment device according to claim 1 wherein the optical radiation providing module is a disposable cartridge comprising:
  - a source of optical radiation;
  - a reflector configured to reflect the emitted optical radiation to the segment of the skin;
  - cooling means operatively adapted to cool the source of optical radiation; and
  - at least one dielectric coated protective window.
5. The skin treatment device according to claim 4 wherein the cooling means are one of a group consisting of a fan and a blower.
6. The skin treatment device according to claim 4 wherein the reflector is a tubular or prismatic case configured to have openings located about the apex of the reflector and allowing air passage in a direction perpendicular to the source of optical radiation and where the air exhaust openings are located at the open butt ends of the reflector.
7. The skin treatment device according to claim 4 wherein the cooling means are operatively configured to form an air flow along the source of optical radiation.

8. The skin treatment device according to claim 4 wherein the source of optical radiation is one of a group of incandescent lamp, LED, laser diode, solid state laser, a gas laser, or a Xenon IPL lamp.
9. The skin treatment device according to claim 4 wherein the optical radiation providing module is a disposable module.
10. The skin treatment device according to claim 4 wherein the dielectric coated protective window serves as a filter and defines the spectrum of the radiation directed to the skin and the aperture through which the radiation is emitted to the skin.
11. The skin treatment device according to claim 4 further comprising at least one additional window, mounted in parallel to said dielectric coated protective window.
12. The skin treatment device according to claim 4, wherein said cooling means are designed to form an air flow between the two windows.
13. The skin treatment device according to claim 4, additionally comprising a slanted lamp electrode mounted on the air intake side of the optical radiation source, said slanted lamp electrode is operative to induce air flow between the two windows.
14. The skin treatment device according to claim 11, wherein at least one window is coated with a dielectric coating designed to reflect back undesired wavelengths emitted from the source of optical radiation.
15. The skin treatment device according to claim 11, further comprising two reflectors mounted between said two windows, on both sides thereof, said reflectors designed to prevent light scattering.
16. The skin treatment device according to claim 4 further comprising a pair of electrodes operatively configured to apply RF energy to a segment of the skin.
17. The skin treatment device according to claim 16 wherein said pair of electrodes is one of a group consisting of metal strips or metal coated non-conductive material and wherein the RF electrodes have an elongated body arranged along at least one side of the protective window.
18. The skin treatment device according to claim 17 wherein the RF electrodes are at least one of a group of uncoated or dielectric coated electrodes.

19. The skin treatment device according to any one of claims 1 and 2 further comprising an infrastructure frame incorporating:
- the radiation providing module;
  - a device across the skin displacement speed monitoring arrangement and a displacement direction sensor attached to the infrastructure frame; and
  - a safety switch mounted on the infrastructure frame and activated by insertion of the radiation providing module.
20. The skin treatment device according to claim 1 further comprising at least one visual status indicator and at least one audio status indicator.
21. The skin treatment device according to claim 19 wherein the RF electrodes are suspended with respect to the infrastructure frame.
22. The skin treatment device according to claim 16 wherein the RF electrodes are at least one of a group of uncoated or dielectric coated electrodes.
23. The skin treatment device according to claim 19 wherein the RF electrodes are in permanent contact with the skin and follow the skin topography.
24. The skin treatment device according to claim 19 wherein the mechanism for continuously displacing the device across the skin is at least one of a group consisting of a DC motor with a gear, a peristaltic piezoceramic motor, or a caterpillar driven by a piezoceramic motor.
25. The skin treatment device according to claim 1 wherein the radiation-providing module operates in a pulse or continuous operation mode and wherein when the radiation providing module operates in pulse mode it radiates pulses of high power interleaved by pulses of low power.
26. The skin treatment device according to claim 1 additionally comprising a device configured to perform a countdown of the number of pulses emitted from the optical radiation providing module and wherein the device is one of a group consisting of an RFID or an EEPROM.
27. The skin treatment device according to claim 1 further comprising cooling air temperature measuring means.
28. A skin treatment device for personal use, said device comprising:

- an optical radiation providing module operating in pulsed or continuous operation mode;
  - a device displacement speed monitoring arrangement ; and
- wherein the optical radiation power and optical radiation pulses repetition rate establish the device displacement speed.

29. A skin treatment device for personal use, said device comprising:

- an optical radiation providing module operating in pulsed or continuous operation mode;
- a mechanism for continuously displacing the device across the skin;
- a device displacement speed monitoring arrangement;
- a skin rejuvenation head; and

wherein the optical pulses repetition rate establishes the power of the optical radiation as a function of the device displacement speed.

30. The skin treatment device according to claim 29 wherein the skin rejuvenation head is a rotating roller with protruding dome shaped contacts.

31. A method of skin treatment, said method comprising:

- applying to a segment of skin a device comprising at least a pair of RF electrodes, an optical radiation providing module, a mechanism operatively configured to continuously displace the device across the skin, a displacement speed monitoring arrangement, and a displacement direction sensor;
- operating the optical radiation providing module to irradiate the segment of the skin;
- monitoring the device displacement speed and providing a speed feedback to a user controlling the device; and

wherein, based on said speed feedback, the device operates the mechanism operatively configured to displace the device and wherein the mechanism automatically displaces the device across the skin as a function of at least the optical radiation power.

32. The method according to claim 31 wherein the device displacement is along the segment of the skin to be treated.

33. The method according to claim 31 wherein when the device reaches the border of the treated skin segment, it is displaced by the user to treat the next skin segment.
34. The method according to claim 31 further comprising enabling contact between the RF electrodes and the skin and coupling RF energy to the skin.
35. The method according to claim 31 further comprising sensing the device displacement direction by a displacement direction sensor, and setting the mechanism to displace the device in a proper direction.
36. The method according to claim 31 further comprising hair removal from said segment of skin and wherein the hair removal precedes skin treatment.
37. The method according to claim 31 wherein the optical radiation providing module irradiates the skin in continuous or pulse mode and wherein the radiation providing module operates in pulse mode to irradiate the skin by pulses of high power interleaved by pulses of low power.
38. A method of safe skin treatment, said method comprising:
- applying a skin treatment device to a skin segment from which hair has to be removed;
  - removing the hair from the skin segment by mechanical means;
  - applying to said skin segment optical radiation of proper power and wavelength and optional RF energy;
  - removing from said skin segment hair residuals left after mechanical hair removal; and
- wherein the device treating the skin segment displaces itself automatically from a treated skin segment to another not treated skin segment.
39. The method for skin treatment according to claim 38 wherein mechanical means removing the hair from the skin segment are at least one of a group of a shaver or a hair epilator.
40. The method for skin treatment according to claim 38 wherein optical radiation of proper power and wavelength removes hair residuals left after mechanical hair removal.

41. A cooling arrangement for cooling a radiation providing module, said arrangement comprising:
- a source of radiation;
  - an elongated reflector with air passage openings allowing air passage inside the reflector, said openings located about the apex of the reflector and along the longitudinal axis of said reflector; and
  - air exhaust openings located at the butt-end of the reflector.
42. The cooling arrangement according to claim 41 wherein the area of the air exhausts openings is equal to or greater than the area of air passage openings located along the longitudinal axis of the reflector.
43. The cooling arrangement according to claim 41 further comprising a dielectric coated protective window adjacent to the open section of the elongated reflector.
44. The cooling arrangement according to claim 43 wherein the elongated reflector and the dielectric coated window form an air-conducting channel.
45. The cooling arrangement according to claim 41 wherein the elongated reflector has a curved or polygonal cross section.
46. The cooling arrangement according to claim 41 wherein air flows in the air conducting channel through longitudinal air passage openings, flows along the channel and is exhausted into the air exhaust openings.
47. A method for cooling an optical radiation providing module, said method comprising:
- directing a stream of cooling air to a reflector of optical radiation providing module;
  - dividing the stream of cooling air such that a part of said air cools the external section of the reflector and a part of the air enters through air passage openings inside the reflector; and
  - cooling the radiation source by directing the air stream inside the reflector along the radiation source, and exhausting the air through butt end openings of the reflector.

48. The method of cooling according to claim 47 further comprising forming an air conducting channel by attaching a glass window to the reflector.
49. The method of cooling according to claim 48 wherein interaction of the air stream with the radiation source and glass window directs the air stream inside the reflector along the radiation source.
50. The method of cooling according to claim 48 wherein the surface of the air exhaust openings is equal to or greater than the surface of longitudinal air passage openings in the reflector.
51. A skin rejuvenation device for personal use, said device comprising:
- a skin rejuvenation head including a source of optical radiation providing high power pulses interleaved with low power pulses at a frequency not annoying a user;
  - at least a pair of RF electrodes operatively configured to apply RF energy to the treated skin segment; and
  - a cooling arrangement operatively configured to cool the source of optical radiation and a temperature sensor operatively configured to sense the cooling air temperature.
52. A skin rejuvenation device according to claim 51 further comprising a mechanism for continuously displacing the device across the skin.
53. A skin rejuvenation device for personal use, said device comprising:
- a skin rejuvenation head including a source of optical radiation providing high power pulses interleaved with low power pulses at a frequency not annoying a user;
  - a counter counting at least the high power; and
  - a device displacement speed monitoring arrangement.
54. A disposable cartridge for cosmetic skin treatment cooling arrangement for cooling a radiation providing module, said arrangement comprising:
- a source of radiation;
  - an elongated tubular or prismatic reflector having a curved or polygonal cross section and air passage openings located about the apex of the

reflector and along the longitudinal axis of said reflector allowing air passage inside the reflector;

- air exhaust openings located at the butt-end of the reflector; and
- a dielectric coated protective window adjacent to the open section of the reflector; and
- a pair of electrodes operatively configured to provide to the treated skin segment RF energy.

55. A skin treatment device for personal use, said device comprising:

- a source of optical radiation operating in pulsed or continuous operation mode;
- a pair of electrodes operatively configured to apply RF energy to a segment of the skin;
- cooling means operatively adapted to cool the source of optical radiation; and
- a hair removal mechanism operatively configured to mechanically remove hair from the target segment of the skin.

56. The skin treatment device according to claim 55 wherein the hair removal mechanism is at least one of a group of a shaver, an epilator, and a razor.

57. The skin treatment device according to claim 55 further comprising a mechanism for continuously displacing the device across the skin.

58. The skin treatment device according to claim 55 wherein the source of optical radiation is a disposable cartridge comprising:

- a reflector configured to reflect the emitted optical radiation to the segment of the skin; and
- at least one dielectric coated protective window.

59. A skin treatment device for personal use, said device comprising:

- a source of optical radiation including a lamp, a reflector configured to reflect the emitted optical radiation to the segment of the skin, and at least one dielectric coated protective window;
- a pair of electrodes operatively configured to apply RF energy to a segment of the skin; and

- cooling means operatively adapted to cool the source of optical radiation.
60. The skin treatment device according to claim 59 further comprising a hair removal mechanism operatively configured to mechanically remove hair from the target segment of the skin.
  61. The skin treatment device according to claim 59 further comprising a mechanism for continuously displacing the device across the skin.
  62. The skin treatment device according to claim 59 further comprising a mechanism for continuously monitoring the device displacement speed across the target segment of the skin.

**AMENDED CLAIMS**

received by the International Bureau on 14 FEBRUARY 2010 (14.02.10)

What is claimed is:

1. A skin treatment device for personal use, said device comprising:
  - an optical radiation providing module operating in pulsed or continuous operation mode;
  - a pair of dielectric coated electrodes operative to couple RF to a segment of skin;
  - a mechanism for continuously displacing the device across the skin; and wherein the mechanism for continuously displacing the device across the skin is at least one of a group consisting of a DC motor with a gear, a peristaltic piezoceramic motor, or a caterpillar driven by a piezoceramic motor.
2. The skin treatment device according to claim 1, further comprising a hair removal mechanism operatively configured to mechanically remove hair from the target segment of the skin.
3. The skin treatment device according to claim 2, wherein the hair removal mechanism is at least one of a group of a shaver, an epilator, and a razor.
4. The skin treatment device according to claim 1, wherein the optical radiation providing module is a disposable cartridge comprising:
  - a source of optical radiation;
  - a reflector configured to reflect the emitted optical radiation to the segment of the skin;
  - cooling means operatively adapted to cool the source of optical radiation; and
  - at least one dielectric coated protective window.
5. The skin treatment device according to claim 4, wherein the cooling means are one of a group consisting of a fan and a blower.
6. The skin treatment device according to claim 4, wherein the reflector is a tubular or prismatic case configured to have openings located about the apex of the

- reflector and allowing air passage in a direction perpendicular to the source of optical radiation and where the air exhaust openings are located at the open butt ends of the reflector.
7. The skin treatment device according to claim 4, wherein the cooling means are operatively configured to form an air flow along the source of optical radiation.
  8. The skin treatment device according to claim 4, wherein the source of optical radiation is one of a group of incandescent lamp, LED, laser diode, solid state laser, a gas laser, or a Xenon IPL lamp.
  9. The skin treatment device according to claim 4, wherein the optical radiation providing module is a disposable module.
  10. The skin treatment device according to claim 4, wherein the dielectric coated protective window serves as a filter and defines the spectrum of the radiation directed to the skin and the aperture through which the radiation is emitted to the skin.
  11. The skin treatment device according to claim 4, further comprising at least one additional window, mounted in parallel to said dielectric coated protective window.
  12. The skin treatment device according to claim 4, wherein said cooling means are designed to form an air flow between the two windows.
  13. The skin treatment device according to claim 4, additionally comprising a slanted lamp electrode mounted on the air intake side of the optical radiation source, said slanted lamp electrode is operative to induce air flow between the two windows.
  14. The skin treatment device according to claim 11, wherein at least one window is coated with a dielectric coating designed to reflect back undesired wavelengths emitted from the source of optical radiation.
  15. The skin treatment device according to claim 11, further comprising two reflectors mounted between said two windows, on both sides thereof, said reflectors designed to prevent light scattering.
  16. The skin treatment device according to claim 1, wherein said pair of RF electrodes and wherein the RF electrodes have an elongated body arranged along at least on one side of the protective window.

17. The skin treatment device according to any one of claims 1 and 2, further comprising an infrastructure frame incorporating:
- the radiation providing module;
  - a device across the skin displacement speed monitoring arrangement and a displacement direction sensor attached to the infrastructure frame; and
  - a safety switch mounted on the infrastructure frame and activated by insertion of the radiation providing module.
18. The skin treatment device according to claim 1, further comprising at least one visual status indicator and at least one audio status indicator.
19. The skin treatment device according to claim 17, wherein the RF electrodes are suspended with respect to the infrastructure frame.
20. The skin treatment device according to claim 16, wherein the RF electrodes are at least one of a group of uncoated or dielectric coated electrodes.
21. The skin treatment device according to claim 17, wherein the RF electrodes are in permanent contact with the skin and follow the skin topography.
22. The skin treatment device according to claim 17, wherein the mechanism for continuously displacing the device across the skin is at least one of a group consisting of a DC motor with a gear, a peristaltic piezoceramic motor, or a caterpillar driven by a piezoceramic motor.
23. The skin treatment device according to claim 1, wherein the radiation-providing module operates in a pulse or continuous operation mode and wherein when the radiation providing module operates in pulse mode it radiates pulses of high power interleaved by pulses of low power.
24. The skin treatment device according to claim 1 additionally comprising a device configured to perform a countdown of the number of pulses emitted from the optical radiation providing module and wherein the device is one of a group consisting of an RFID or an EEPROM.
25. The skin treatment device according to claim 1 further comprising cooling air temperature measuring means.
26. A skin treatment device for personal use, said device comprising:

- an optical radiation providing module operating in pulsed or continuous operation mode;
  - a device displacement speed monitoring arrangement; and
- wherein the optical radiation power and optical radiation pulses repetition rate establish the device displacement speed.

27. A skin treatment device for personal use, said device comprising:

- an optical radiation providing module operating in pulsed or continuous operation mode;
- a mechanism for continuously displacing the device across the skin;
- a device displacement speed and displacement direction monitoring arrangement;
- a skin rejuvenation head in form of a rotating roller with protruding dome shaped contacts; and

wherein the optical pulses repetition rate establishes the power of the optical radiation as a function of the device displacement speed.

28. A method of skin treatment, said method comprising:

- applying to a segment of skin a device comprising at least a pair of RF electrodes, an optical radiation providing module, a mechanism operatively configured to continuously displace the device across the skin, a displacement speed monitoring arrangement, and a displacement direction sensor;
- operating the optical radiation providing module to irradiate the segment of the skin;
- monitoring the device displacement speed and providing a speed feedback to a user controlling the device; and

wherein, based on said speed feedback, the device operates the mechanism operatively configured to displace the device and wherein the mechanism automatically displaces the device across the skin as a function of at least the optical radiation power.

29. The method according to claim 28, wherein the device displacement is along the segment of the skin to be treated.
30. The method according to claim 28, wherein when the device reaches the border of the treated skin segment, it is displaced by the user to treat the next skin segment.
31. The method according to claim 28, further comprising enabling contact between the RF electrodes and the skin and coupling RF energy to the skin.
32. The method according to claim 28, further comprising sensing the device displacement direction by a displacement direction sensor, and setting the mechanism to displace the device in a proper direction.
33. The method according to claim 28, further comprising hair removal from said segment of skin and wherein the hair removal precedes skin treatment.
34. The method according to claim 28, wherein the optical radiation providing module irradiates the skin in continuous or pulse mode and wherein the radiation providing module operates in pulse mode to irradiate the skin by pulses of high power interleaved by pulses of low power.
35. A method of safe skin treatment, said method comprising:
- applying a skin treatment device to a skin segment from which hair has to be removed;
  - removing the hair from the skin segment by mechanical means;
  - applying to said skin segment optical radiation of proper power and wavelength and optional RF energy;
  - removing from said skin segment hair residuals left after mechanical hair removal; and
- wherein the device treating the skin segment displaces itself automatically from a treated skin segment to another not treated skin segment.
36. The method for skin treatment according to claim 35, wherein mechanical means removing the hair from the skin segment are at least one of a group of a shaver or a hair epilator.

37. The method for skin treatment according to claim 35, wherein optical radiation of proper power and wavelength removes hair residuals left after mechanical hair removal.
38. A cooling arrangement for cooling a radiation providing module, said arrangement comprising:
- a source of radiation;
  - an elongated reflector with air passage openings allowing air passage inside the reflector, said openings located about the apex of the reflector and along the longitudinal axis of said reflector; and
  - air exhaust openings located at the butt-end of the reflector.
39. The cooling arrangement according to claim 38, wherein the area of the air exhausts openings is equal to or greater than the area of air passage openings located along the longitudinal axis of the reflector.
40. The cooling arrangement according to claim 38, further comprising a dielectric coated protective window adjacent to the open section of the elongated reflector and wherein the elongated reflector and the dielectric coated window form an air-conducting channel.
41. The cooling arrangement according to claim 38, wherein the elongated reflector has a curved or polygonal cross section.
42. The cooling arrangement according to claim 38, wherein air flows in the air conducting channel through longitudinal air passage openings, flows along the channel and is exhausted into the air exhaust openings.
43. A method for cooling an optical radiation providing module, said method comprising:
- directing a stream of cooling air to a reflector of optical radiation providing module;
  - dividing the stream of cooling air such that a part of said air cools the external section of the reflector and a part of the air enters through air passage openings inside the reflector; and

- cooling the radiation source by directing the air stream inside the reflector along the radiation source, and exhausting the air through butt end openings of the reflector.
44. The method of cooling according to claim 43, further comprising forming an air conducting channel by attaching a glass window to the reflector.
45. The method of cooling according to claim 44, wherein interaction of the air stream with the radiation source and glass window directs the air stream inside the reflector along the radiation source.
46. The method of cooling according to claim 44, wherein the surface of the air exhaust openings is equal to or greater than the surface of longitudinal air passage openings in the reflector.
47. A skin rejuvenation device for personal use, said device comprising:
- a skin rejuvenation head including a source of optical radiation providing high power pulses interleaved with low power pulses at a frequency not annoying a user;
  - at least a pair of RF electrodes operatively configured to apply RF energy to the treated skin segment; and
  - a cooling arrangement operatively configured to cool the source of optical radiation and a temperature sensor operatively configured to sense the cooling air temperature.
48. A skin rejuvenation device according to claim 47, further comprising a mechanism for continuously displacing the device across the skin.
49. A skin rejuvenation device for personal use, said device comprising:
- a skin rejuvenation head including a source of optical radiation providing high power pulses interleaved with low power pulses at a frequency not annoying a user;
  - a counter counting at least the high power; and
  - a device displacement speed monitoring arrangement.
50. A disposable cartridge for cosmetic skin treatment cooling arrangement for cooling a radiation providing module, said arrangement comprising:

- a source of radiation;
- an elongated tubular or prismatic reflector having a curved or polygonal cross section and air passage openings located about the apex of the reflector and along the longitudinal axis of said reflector allowing air passage inside the reflector;
- air exhaust openings located at the butt-end of the reflector; and
- a dielectric coated protective window adjacent to the open section of the reflector; and
- a pair of dielectric coated electrodes operatively configured to provide to the treated skin segment RF energy.

51. A skin treatment device for personal use, said device comprising:

- a source of optical radiation operating in pulsed or continuous operation mode;
- a pair of dielectric coated electrodes operatively configured to apply RF energy to a segment of the skin;
- cooling means operatively adapted to cool the source of optical radiation; and
- a hair removal mechanism operatively configured to mechanically remove hair from the target segment of the skin.

52. The skin treatment device according to claim 51, wherein the hair removal mechanism is at least one of a group of a shaver, an epilator, and a razor.

53. The skin treatment device according to claim 51, further comprising a mechanism for continuously displacing the device across the skin.

54. The skin treatment device according to claim 51, wherein the source of optical radiation is a disposable cartridge comprising:

- a reflector configured to reflect the emitted optical radiation to the segment of the skin; and
- at least one dielectric coated protective window.

55. A skin treatment device for personal use, said device comprising:

- a source of optical radiation including a lamp, a reflector configured to reflect the emitted optical radiation to the segment of the skin, and at least one dielectric coated protective window;
  - a pair of dielectric coated electrodes operatively configured to apply RF energy to a segment of the skin; and
  - cooling means operatively adapted to cool the source of optical radiation.
56. The skin treatment device according to claim 55, further comprising a hair removal mechanism operatively configured to mechanically remove hair from the target segment of the skin.
57. The skin treatment device according to claim 55, further comprising a mechanism for continuously displacing the device across the skin.
58. The skin treatment device according to claim 55, further comprising a mechanism for continuously monitoring the device displacement speed across the target segment of the skin.
59. A skin treatment device for personal use, said device comprising:
- at least one source of optical radiation operatively configured to apply optical radiation to a treated segment of skin, said radiation being composed of high power pulses interleaved with low power pulses at a repetition rate not annoying a user;
  - at least one hair removal mechanism operatively configured to remove hair from the treated skin segment; and
- wherein the hair removal mechanism is at least one of a group of cartridges consisting of an electric shaver, an electric epilator, and a razor and wherein the hair removal cartridges are exchangeable between them.
60. The skin treatment device according to claim 59, further comprising at least a pair of RF electrodes operative to apply RF voltage to a treated segment of skin.
61. The skin treatment device according to claim 59, further comprising a skin rejuvenation cartridge, said module exchangeable with at least one of the hair removal cartridges.
62. A skin treatment device for personal use, said device comprising:

- at least one source of optical radiation operatively configured to apply optical radiation to a treated segment of skin, said radiation being composed of pulses at a repetition rate not annoying a user;
- at least one hair removal mechanism operatively configured to remove hair from the treated skin segment;
- a pair of dielectric coated electrodes operatively configured to apply RF energy to a segment of the skin; and

wherein the hair removal mechanism is at least one of a group of mechanisms consisting of a shaver, an epilator, and a razor and wherein the hair removal mechanisms.

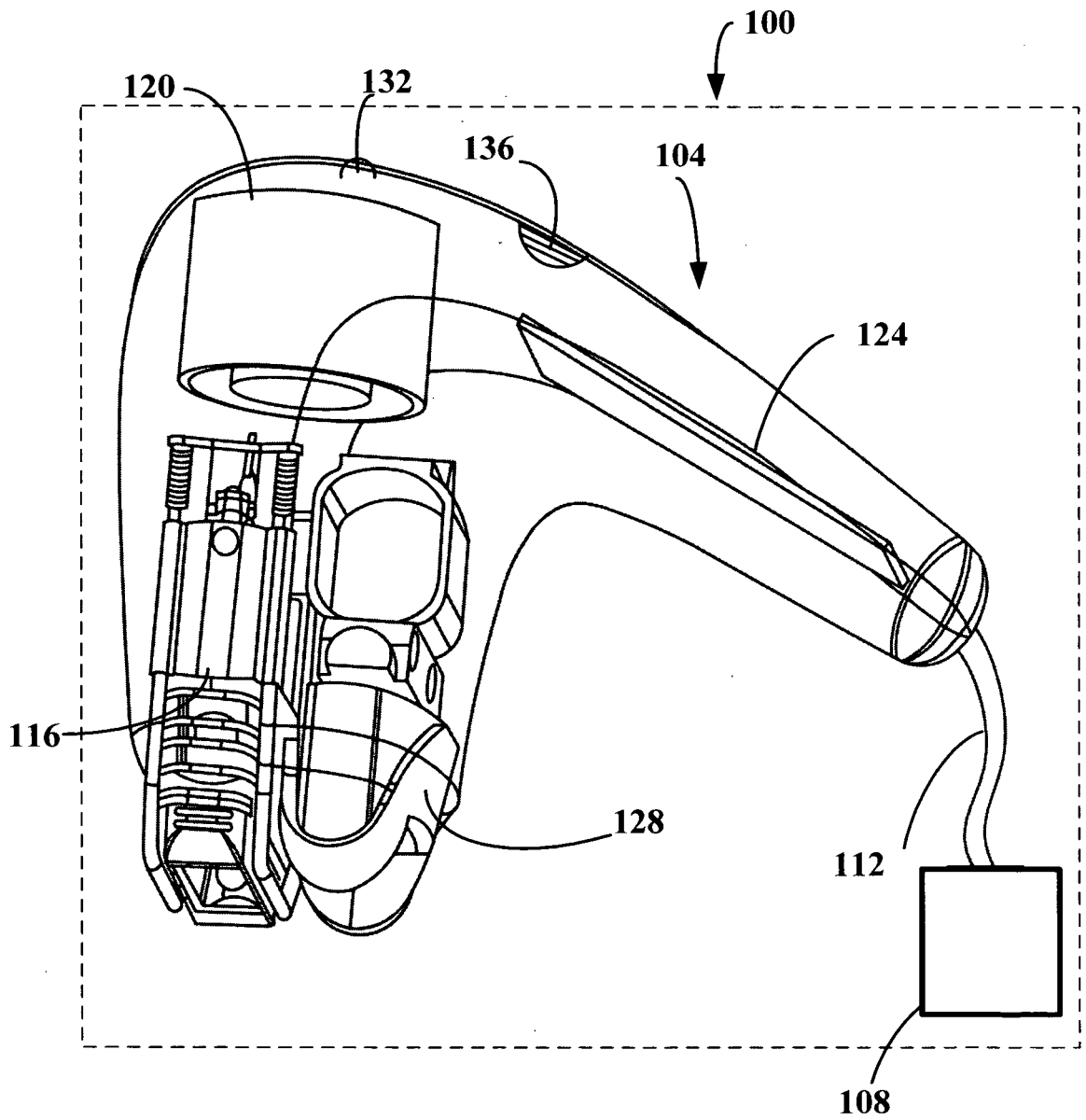

FIG. 1

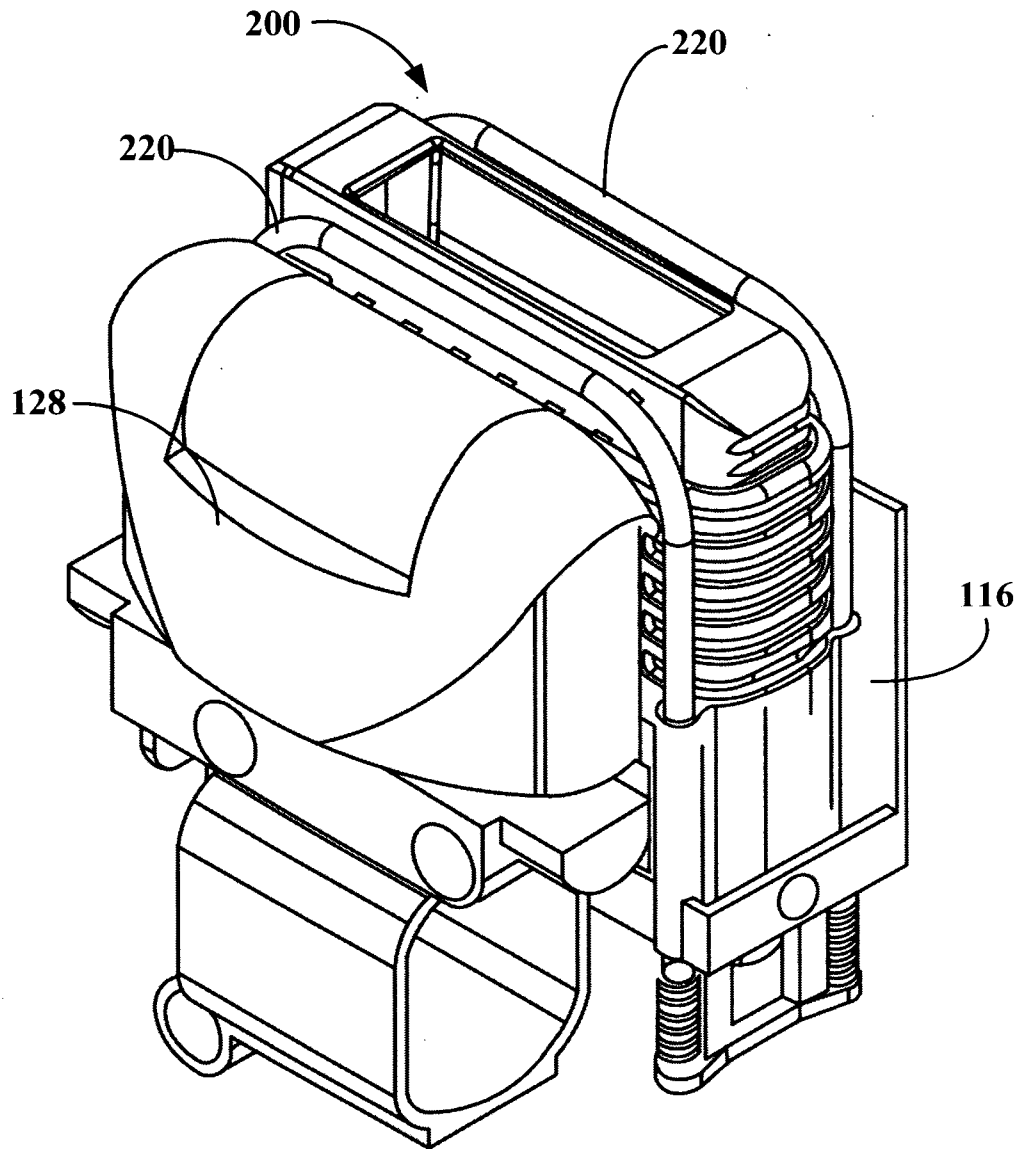
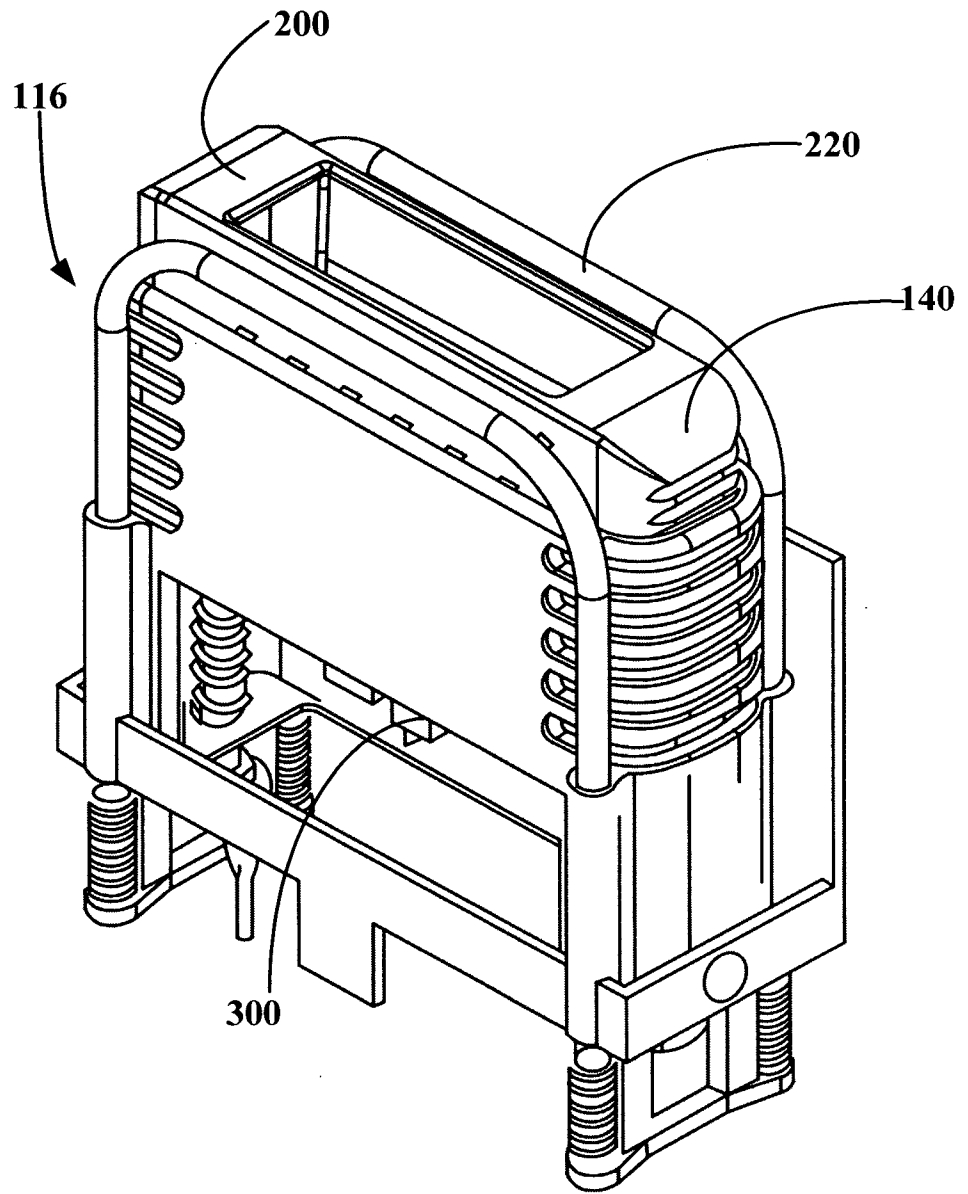

FIG. 2



**FIG. 3**

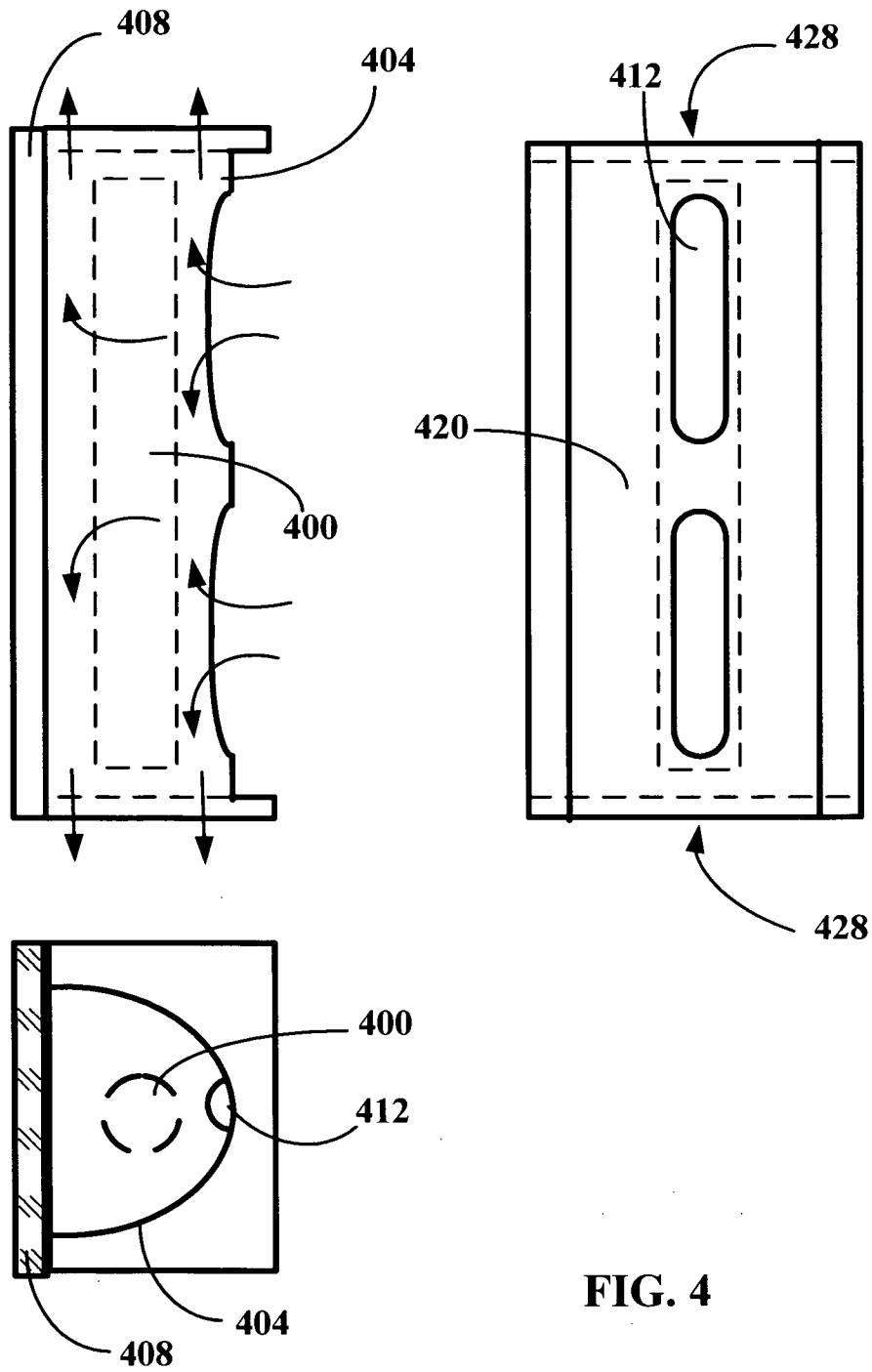
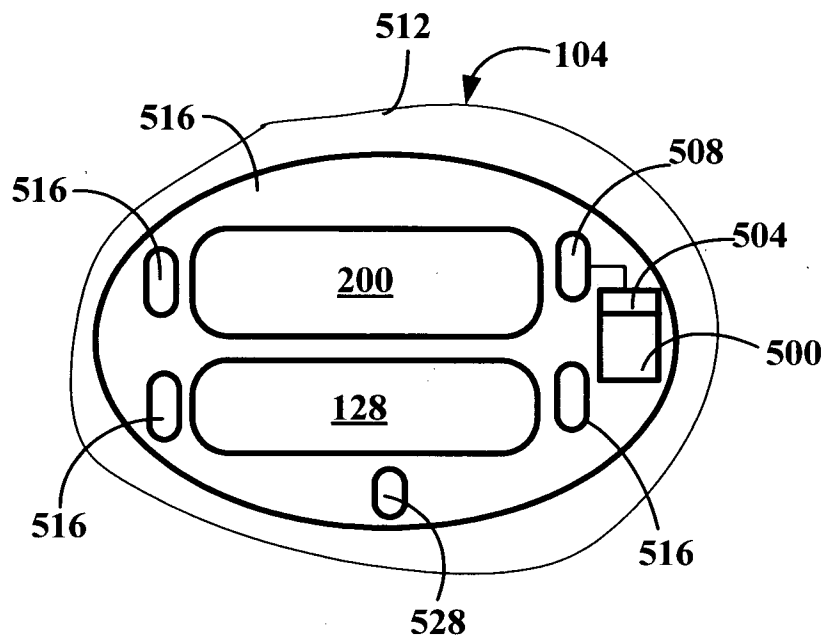
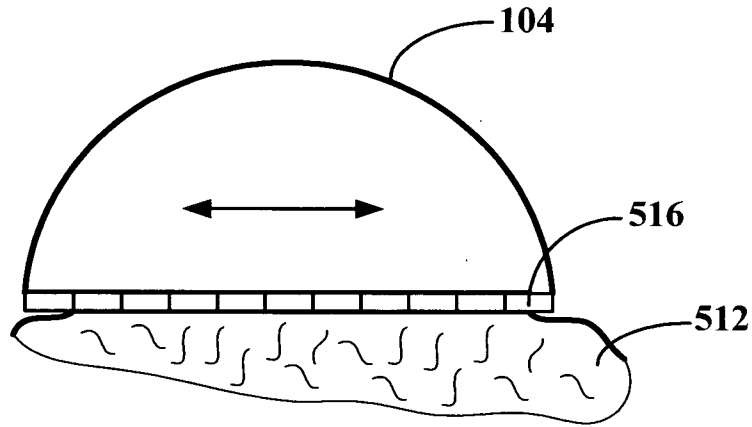

FIG. 4



**FIG. 5A**



**FIG. 5B**

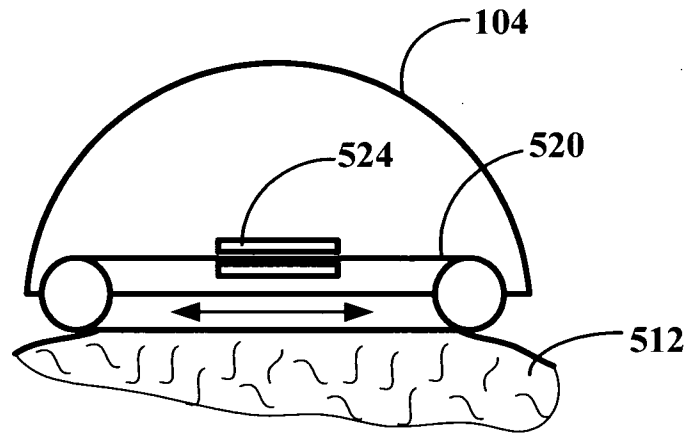

**FIG. 5C**

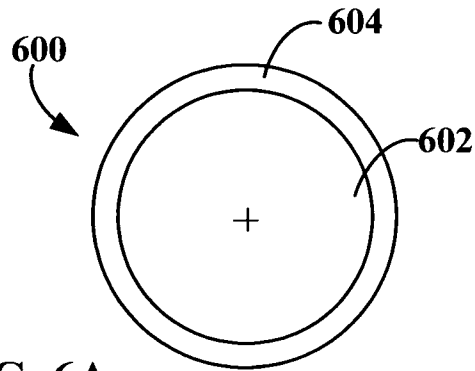

FIG. 6A

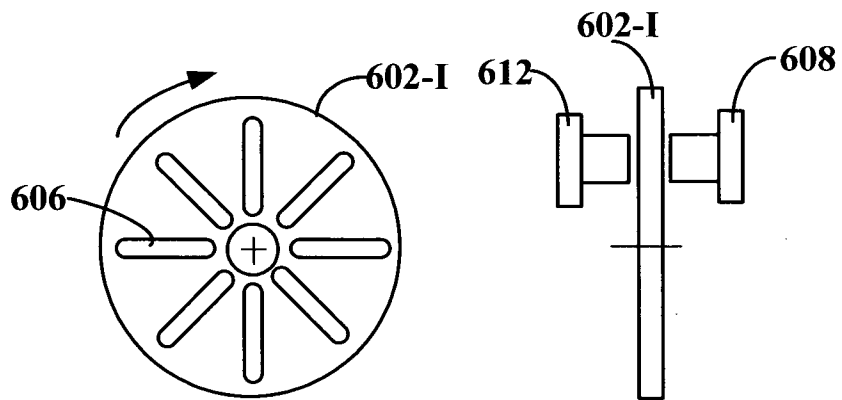

FIG. 6B

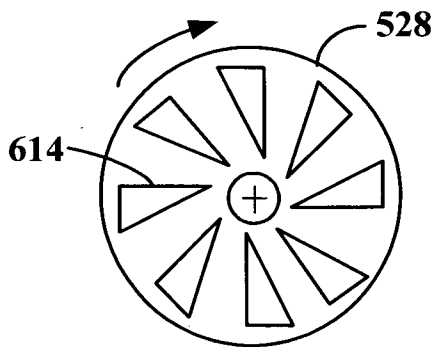

FIG. 6C

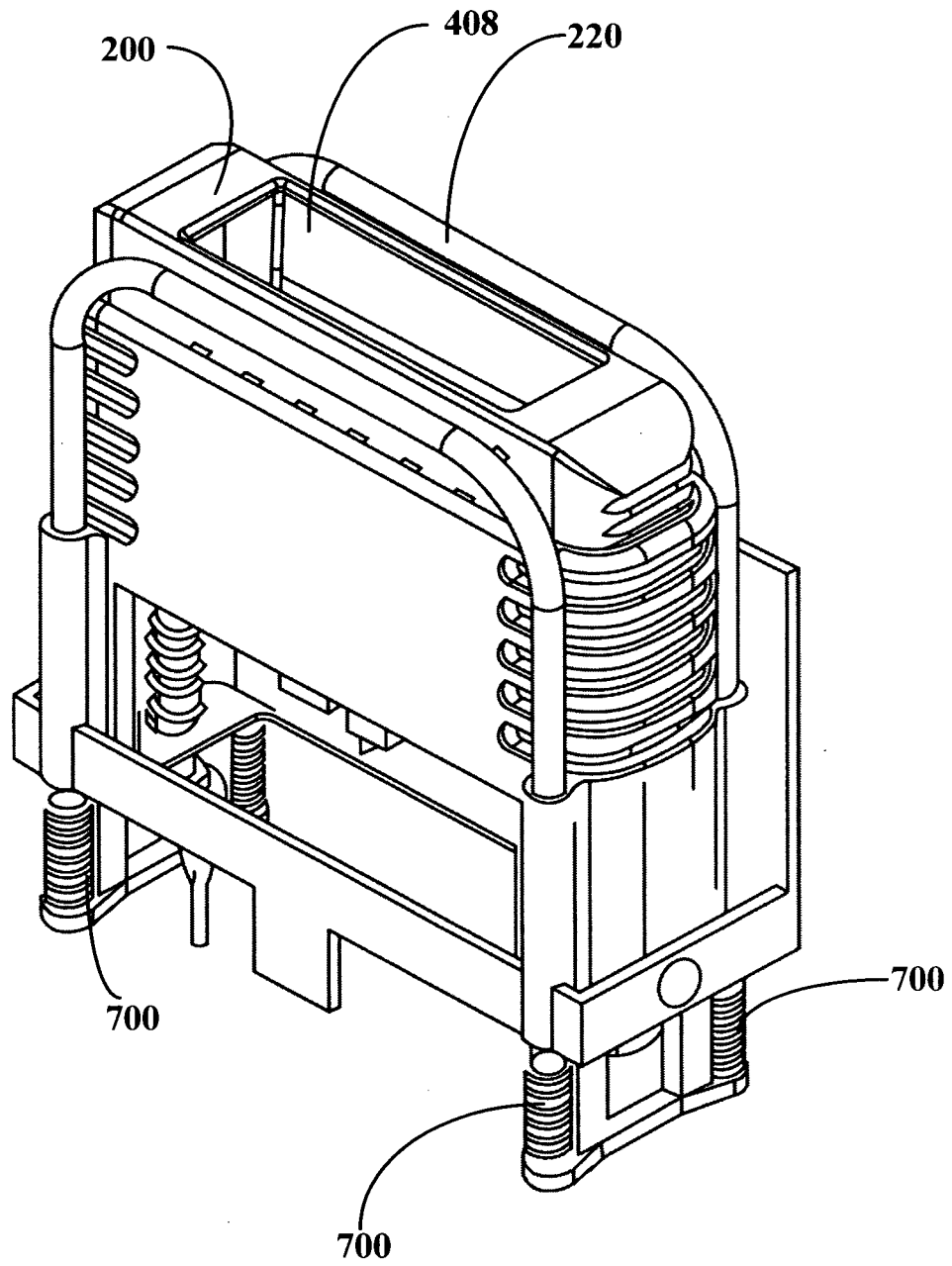
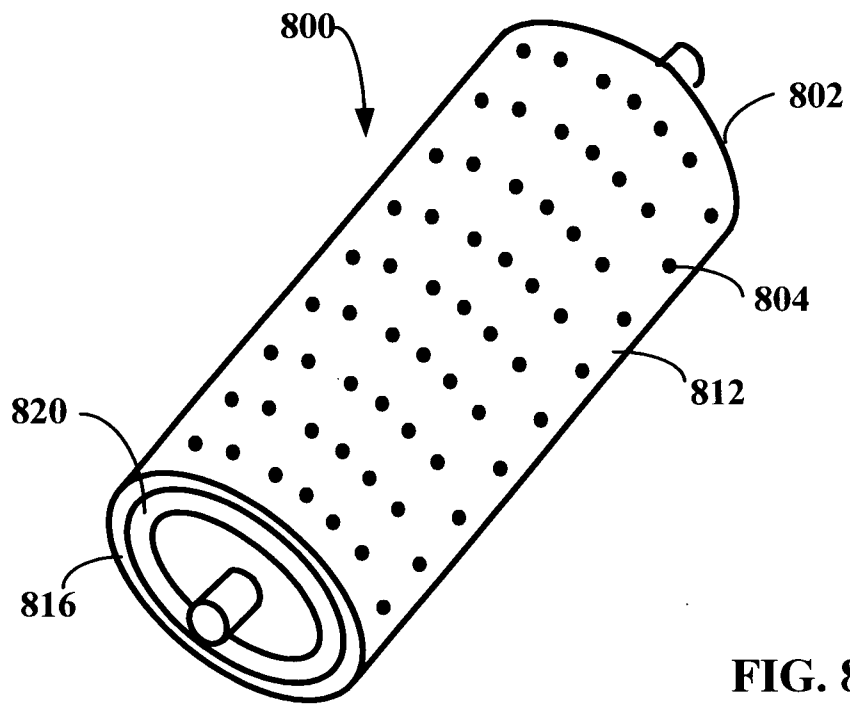

FIG. 7



**FIG. 8**

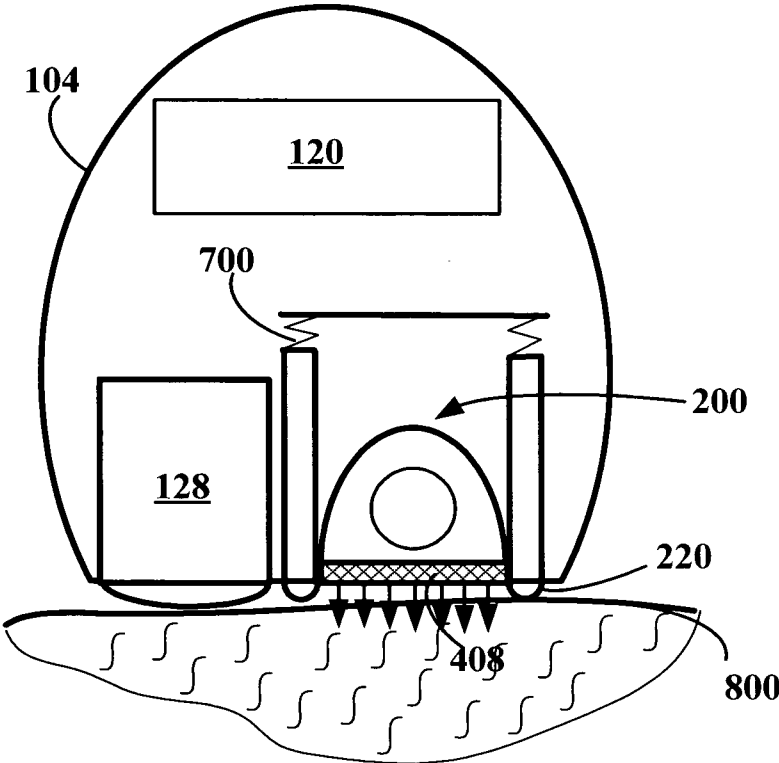

FIG. 9

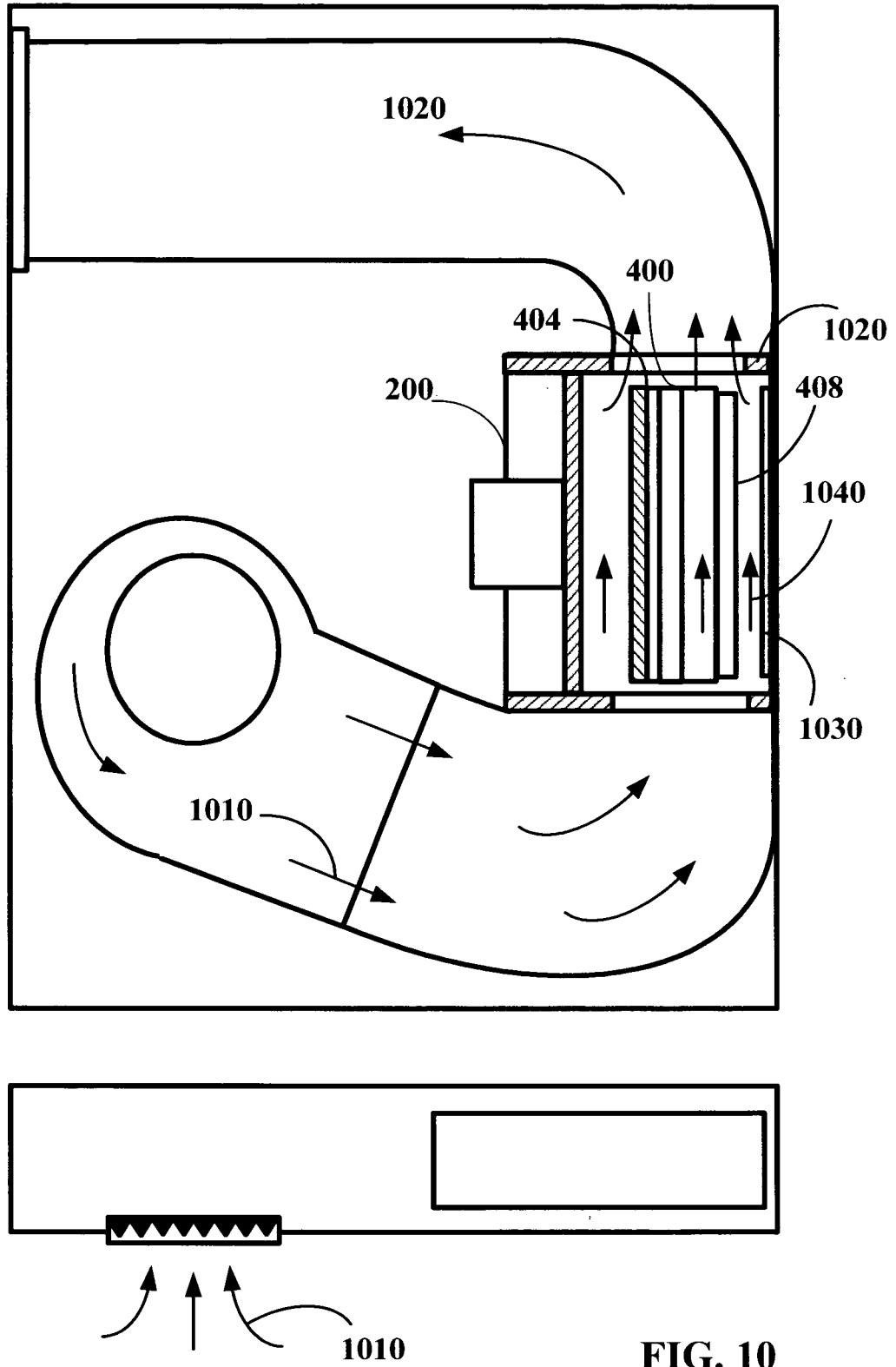

FIG. 10

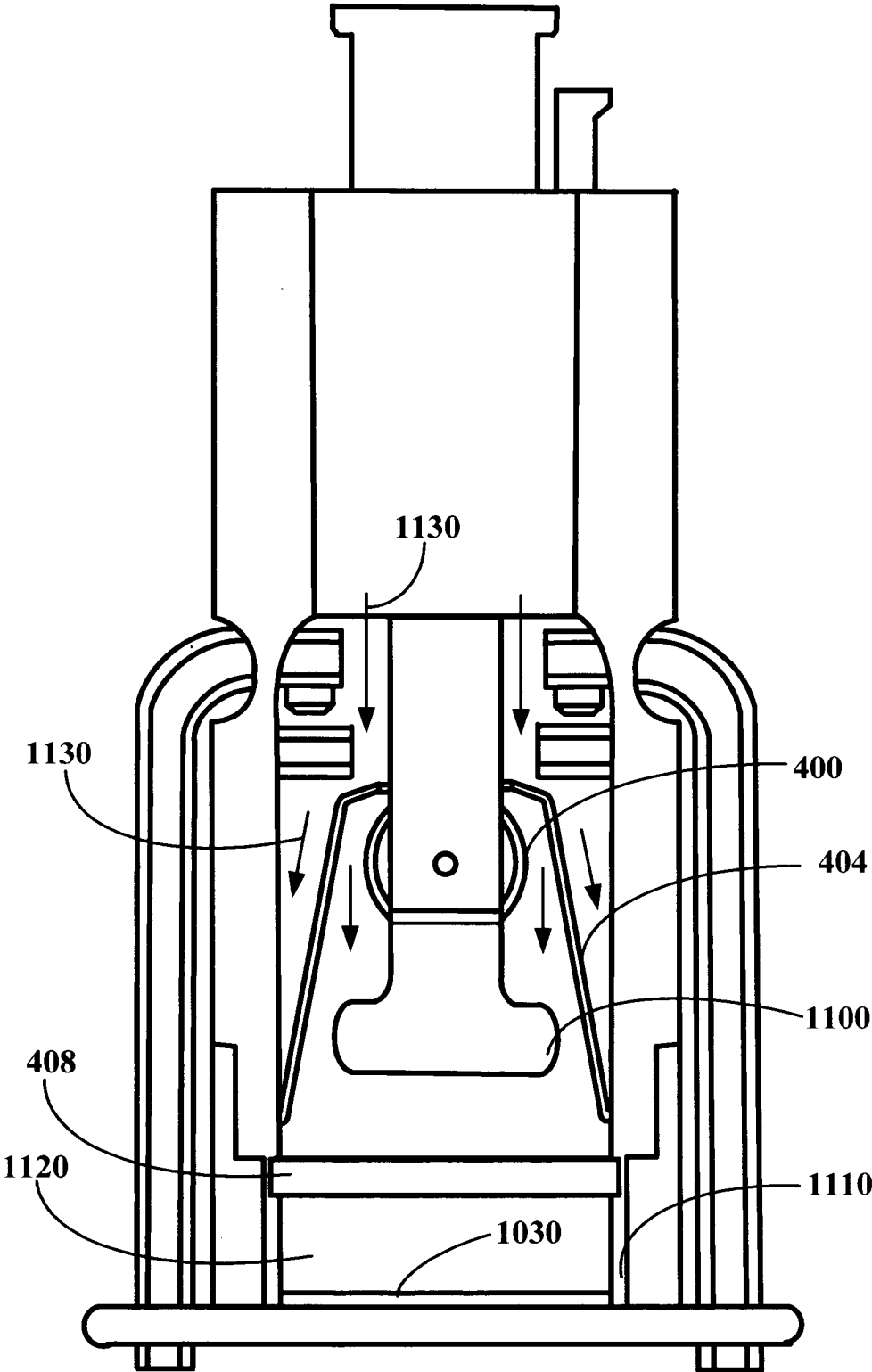

FIG. 11

**INTERNATIONAL SEARCH REPORT**

International application No.

PCT/IL 09/00817

<p><b>A. CLASSIFICATION OF SUBJECT MATTER</b>                  IPC(8) - A61B 18/18 (2009.01)                  USPC - 606/9                  According to International Patent Classification (IPC) or to both national classification and IPC</p>																																
<p><b>B. FIELDS SEARCHED</b></p> <p>Minimum documentation searched (classification system followed by classification symbols)                  USPC: 606/9</p> <p>Documentation searched other than minimum documentation to the extent that such documents are included in the fields searched                  USPC: 606/9; 604/20, 22; 607/88, 89                  See Search Terms Below</p> <p>Electronic data base consulted during the international search (name of data base and, where practicable, search terms used)                  pubWEST(PGPB,USPT,EPAB,JPAB); USPTO; Google Web                  Search Terms Used: rf, electrode, exhaust, vent, shaver, razor, epilator, cool\$3, fan, optical, energy, source, radiation, hair, remov\$3, skin, tissue, treat\$3, motor, mov\$, distance, displacement</p>																																
<p><b>C. DOCUMENTS CONSIDERED TO BE RELEVANT</b></p> <table border="1"> <thead> <tr> <th>Category*</th> <th>Citation of document, with indication, where appropriate, of the relevant passages</th> <th>Relevant to claim No.</th> </tr> </thead> <tbody> <tr> <td>X</td> <td>US 2007/0129711 A1 (Altschuler et al) 07 June 2007 (07.06.2007) para [0073], [0077]-[0078], [0081], [0082], [0089], [0102], [0109], [0125], [0129], [0131], [0135], [0139], [0141]-[0142], [0150]-[0152], [0156], [0158], [0165]-[0166], [0171], [0176], [0188], [0202], fig 6D, 13</td> <td>28, 51, 53, 55-56, 58-60</td> </tr> <tr> <td>Y</td> <td>US 2004/0236269 A1 (MARCHITTO et al) 25 November 2004 (25.11.2004); Fig. 1; para [0039]</td> <td>1-27, 29-50, 52, 54, 57, 61-62</td> </tr> <tr> <td>Y</td> <td>US 2004/0143308 A1 (LUNDAHL et al) 22 July 2004 (22.07.2004) para [0064], [0067]-[0068], fig 1</td> <td>1-27, 29-40, 52, 57, 61-62</td> </tr> <tr> <td>Y</td> <td>US 2004/0143308 A1 (LUNDAHL et al) 22 July 2004 (22.07.2004) para [0064], [0067]-[0068], fig 1</td> <td>5-6, 41-50, 54</td> </tr> <tr> <td>Y</td> <td>US 6,770,069 B1 (HOBART et al) 03 August 2004 (03.08.2004) col 5, ln 37-41, fig 3A</td> <td>12</td> </tr> <tr> <td>Y</td> <td>US 2008/0215124 A1 (WAGENAAR et al) 04 September 2008 (04.09.2008) para [0046]</td> <td>13</td> </tr> <tr> <td>Y</td> <td>US 2005/0015042 A1 (SUN et al) 20 January 2005 (20.01.2005) para [0161]</td> <td>18, 22</td> </tr> <tr> <td>Y</td> <td>US 2006/0231568 A1 (LYNN et al) 19 October 2006 (19.10.2006) para [0042]</td> <td>26</td> </tr> <tr> <td>Y</td> <td>US 2008/0221504 A1 (AGHION) 11 September 2008 (11.09.2008); Fig. 1A; para[0033]</td> <td>30</td> </tr> </tbody> </table>			Category*	Citation of document, with indication, where appropriate, of the relevant passages	Relevant to claim No.	X	US 2007/0129711 A1 (Altschuler et al) 07 June 2007 (07.06.2007) para [0073], [0077]-[0078], [0081], [0082], [0089], [0102], [0109], [0125], [0129], [0131], [0135], [0139], [0141]-[0142], [0150]-[0152], [0156], [0158], [0165]-[0166], [0171], [0176], [0188], [0202], fig 6D, 13	28, 51, 53, 55-56, 58-60	Y	US 2004/0236269 A1 (MARCHITTO et al) 25 November 2004 (25.11.2004); Fig. 1; para [0039]	1-27, 29-50, 52, 54, 57, 61-62	Y	US 2004/0143308 A1 (LUNDAHL et al) 22 July 2004 (22.07.2004) para [0064], [0067]-[0068], fig 1	1-27, 29-40, 52, 57, 61-62	Y	US 2004/0143308 A1 (LUNDAHL et al) 22 July 2004 (22.07.2004) para [0064], [0067]-[0068], fig 1	5-6, 41-50, 54	Y	US 6,770,069 B1 (HOBART et al) 03 August 2004 (03.08.2004) col 5, ln 37-41, fig 3A	12	Y	US 2008/0215124 A1 (WAGENAAR et al) 04 September 2008 (04.09.2008) para [0046]	13	Y	US 2005/0015042 A1 (SUN et al) 20 January 2005 (20.01.2005) para [0161]	18, 22	Y	US 2006/0231568 A1 (LYNN et al) 19 October 2006 (19.10.2006) para [0042]	26	Y	US 2008/0221504 A1 (AGHION) 11 September 2008 (11.09.2008); Fig. 1A; para[0033]	30
Category*	Citation of document, with indication, where appropriate, of the relevant passages	Relevant to claim No.																														
X	US 2007/0129711 A1 (Altschuler et al) 07 June 2007 (07.06.2007) para [0073], [0077]-[0078], [0081], [0082], [0089], [0102], [0109], [0125], [0129], [0131], [0135], [0139], [0141]-[0142], [0150]-[0152], [0156], [0158], [0165]-[0166], [0171], [0176], [0188], [0202], fig 6D, 13	28, 51, 53, 55-56, 58-60																														
Y	US 2004/0236269 A1 (MARCHITTO et al) 25 November 2004 (25.11.2004); Fig. 1; para [0039]	1-27, 29-50, 52, 54, 57, 61-62																														
Y	US 2004/0143308 A1 (LUNDAHL et al) 22 July 2004 (22.07.2004) para [0064], [0067]-[0068], fig 1	1-27, 29-40, 52, 57, 61-62																														
Y	US 2004/0143308 A1 (LUNDAHL et al) 22 July 2004 (22.07.2004) para [0064], [0067]-[0068], fig 1	5-6, 41-50, 54																														
Y	US 6,770,069 B1 (HOBART et al) 03 August 2004 (03.08.2004) col 5, ln 37-41, fig 3A	12																														
Y	US 2008/0215124 A1 (WAGENAAR et al) 04 September 2008 (04.09.2008) para [0046]	13																														
Y	US 2005/0015042 A1 (SUN et al) 20 January 2005 (20.01.2005) para [0161]	18, 22																														
Y	US 2006/0231568 A1 (LYNN et al) 19 October 2006 (19.10.2006) para [0042]	26																														
Y	US 2008/0221504 A1 (AGHION) 11 September 2008 (11.09.2008); Fig. 1A; para[0033]	30																														
<p><input type="checkbox"/> Further documents are listed in the continuation of Box C. <input type="checkbox"/></p>																																
<p>* Special categories of cited documents:</p> <table border="0"> <tr> <td>"A" document defining the general state of the art which is not considered to be of particular relevance</td> <td>"T" later document published after the international filing date or priority date and not in conflict with the application but cited to understand the principle or theory underlying the invention</td> </tr> <tr> <td>"E" earlier application or patent but published on or after the international filing date</td> <td>"X" document of particular relevance; the claimed invention cannot be considered novel or cannot be considered to involve an inventive step when the document is taken alone</td> </tr> <tr> <td>"L" document which may throw doubts on priority claim(s) or which is cited to establish the publication date of another citation or other special reason (as specified)</td> <td>"Y" document of particular relevance; the claimed invention cannot be considered to involve an inventive step when the document is combined with one or more other such documents, such combination being obvious to a person skilled in the art</td> </tr> <tr> <td>"O" document referring to an oral disclosure, use, exhibition or other means</td> <td>"&amp;" document member of the same patent family</td> </tr> <tr> <td>"P" document published prior to the international filing date but later than the priority date claimed</td> <td></td> </tr> </table>			"A" document defining the general state of the art which is not considered to be of particular relevance	"T" later document published after the international filing date or priority date and not in conflict with the application but cited to understand the principle or theory underlying the invention	"E" earlier application or patent but published on or after the international filing date	"X" document of particular relevance; the claimed invention cannot be considered novel or cannot be considered to involve an inventive step when the document is taken alone	"L" document which may throw doubts on priority claim(s) or which is cited to establish the publication date of another citation or other special reason (as specified)	"Y" document of particular relevance; the claimed invention cannot be considered to involve an inventive step when the document is combined with one or more other such documents, such combination being obvious to a person skilled in the art	"O" document referring to an oral disclosure, use, exhibition or other means	"&" document member of the same patent family	"P" document published prior to the international filing date but later than the priority date claimed																					
"A" document defining the general state of the art which is not considered to be of particular relevance	"T" later document published after the international filing date or priority date and not in conflict with the application but cited to understand the principle or theory underlying the invention																															
"E" earlier application or patent but published on or after the international filing date	"X" document of particular relevance; the claimed invention cannot be considered novel or cannot be considered to involve an inventive step when the document is taken alone																															
"L" document which may throw doubts on priority claim(s) or which is cited to establish the publication date of another citation or other special reason (as specified)	"Y" document of particular relevance; the claimed invention cannot be considered to involve an inventive step when the document is combined with one or more other such documents, such combination being obvious to a person skilled in the art																															
"O" document referring to an oral disclosure, use, exhibition or other means	"&" document member of the same patent family																															
"P" document published prior to the international filing date but later than the priority date claimed																																
<p>Date of the actual completion of the international search                  14 December 2009 (14.12.2009)</p>		<p>Date of mailing of the international search report  <b>07 JAN 2010</b></p>																														
<p>Name and mailing address of the ISA/US                  Mail Stop PCT, Attn: ISA/US, Commissioner for Patents                  P.O. Box 1450, Alexandria, Virginia 22313-1450                  Facsimile No. 571-273-3201</p>		<p>Authorized officer:                  Lee W. Young                  PCT Helpdesk: 571-272-4300                  PCT OSP: 571-272-7774</p>																														