

(12) STANDARD PATENT
(19) AUSTRALIAN PATENT OFFICE

(11) Application No. **AU 2013221124 B2**

(54) Title
Dual venturi for combustion apparatus

(51) International Patent Classification(s)
F23D 14/46 (2006.01) **F23D 14/62** (2006.01)
F23D 14/60 (2006.01) **F23N 5/00** (2006.01)

(21) Application No: **2013221124** (22) Date of Filing: **2013.01.18**

(87) WIPO No: **WO13/122332**

(30) Priority Data

(31) Number	(32) Date	(33) Country
10-2012-0015097	2012.02.15	KR

(43) Publication Date: **2013.08.22**

(44) Accepted Journal Date: **2015.10.01**

(71) Applicant(s)
Kyungdong Navien Co., Ltd.

(72) Inventor(s)
Yu, Jeong Gi

(74) Agent / Attorney
AJ PARK, L 9 Nishi 2 Phillip Law St, Canberra, ACT, 2601

(56) Related Art
US 2011/0139045
KR 10-2002-0033858
KR 10-2006-0028583
KR 20-0387916
JP 11-108352

(12) 특허협력조약에 의하여 공개된 국제출원

(19) 세계지식재산권기구
국제사무국



(43) 국제공개일
2013년 8월 22일 (22.08.2013)

WIPO | PCT

(10) 국제공개번호
WO 2013/122332 A1

- (51) 국제특허분류:
F23D 14/46 (2006.01) F23D 14/60 (2006.01)
F23D 14/62 (2006.01) F23N 5/00 (2006.01)
- (21) 국제출원번호: PCT/KR2013/000429
- (22) 국제출원일: 2013년 1월 18일 (18.01.2013)
- (25) 출원언어: 한국어
- (26) 공개언어: 한국어
- (30) 우선권정보:
10-2012-0015097 2012년 2월 15일 (15.02.2012) KR
- (71) 출원인: 주식회사 경동나비엔 (KYUNG DONG NAVI-EN CO., LTD.) [KR/KR]; 450-818 경기도 평택시 세교동 437, Gyeonggi-do (KR).
- (72) 발명자: 유정기 (YU, Jeong Gi); 423-704 경기도 광명시 광명 4동 한진아파트 108동 1206호, Gyeonggi-do (KR).
- (74) 대리인: 조철현 (CHO, Chul-Hyun); 135-748 서울시 강남구 역삼1동 648-23 여삼빌딩 13층 1301호 우리특허법률사무소, Seoul (KR).
- (81) 지정국 (별도의 표시가 없는 한, 가능한 모든 종류의 국내 권리의 보호를 위하여): AE, AG, AL, AM, AO, AT, AU, AZ, BA, BB, BG, BH, BN, BR, BW, BY, BZ, CA, CH, CL, CN, CO, CR, CU, CZ, DE, DK, DM, DO, DZ, EC, EE, EG, ES, FI, GB, GD, GE, GH, GM, GT, HN, HR, HU, ID, IL, IN, IS, JP, KE, KG, KM, KN, KP, KZ, LA, LC, LK, LR, LS, LT, LU, LY, MA, MD, ME, MG, MK, MN, MW, MX, MY, MZ, NA, NG, NI, NO, NZ, OM, PA, PE, PG, PH, PL, PT, QA, RO, RS, RU, RW, SC, SD, SE, SG, SK, SL, SM, ST, SV, SY, TH, TJ, TM, TN, TR, TT, TZ, UA, UG, US, UZ, VC, VN, ZA, ZM, ZW.
- (84) 지정국 (별도의 표시가 없는 한, 가능한 모든 종류의 역내 권리의 보호를 위하여): ARIPO (BW, GH, GM, KE, LR, LS, MW, MZ, NA, RW, SD, SL, SZ, TZ, UG, ZM, ZW), 유라시아 (AM, AZ, BY, KG, KZ, RU, TJ, TM), 유럽 (AL, AT, BE, BG, CH, CY, CZ, DE, DK, EE, ES, FI, FR, GB, GR, HR, HU, IE, IS, IT, LT, LU, LV, MC, MK, MT, NL, NO, PL, PT, RO, RS, SE, SI, SK, SM, TR), OAPI (BF, BJ, CF, CG, CI, CM, GA, GN, GQ, GW, ML, MR, NE, SN, TD, TG).

공개:

— 국제조사보고서와 함께 (조약 제 21 조(3))

(54) Title: DUAL VENTURI FOR COMBUSTION APPARATUS

(54) 발명의 명칭 : 연소기기용 듀얼 벤츄리

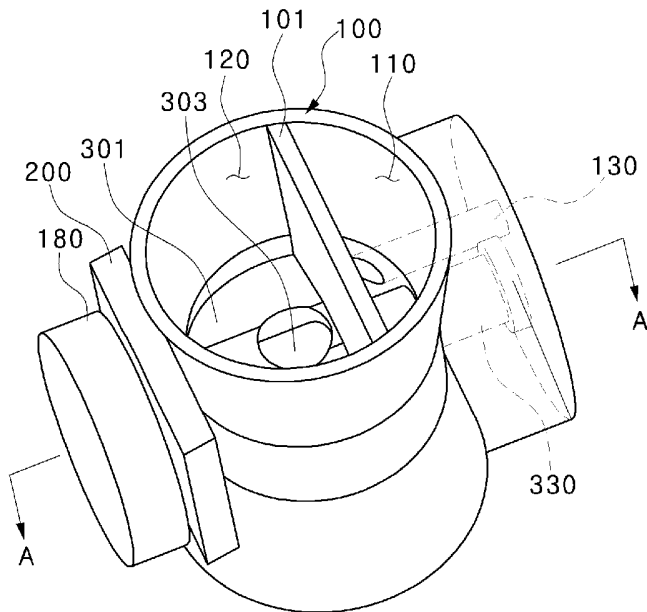

(57) Abstract: The present invention relates to a dual venturi for a combustion apparatus, and more particularly, to a dual venturi for a combustion apparatus that is capable of effectively controlling calorific power since the amount of gas for a burner provided in a water heater and the amount of supplied air are controlled in two phases, and a motor and a damper are coupled to each other so that the damper opens or blocks inlets for secondary air and the gas at the same time that the damper is rotated by the driving of the motor. The present invention includes: a housing that is a cylindrical duct where a first passage and a second passage are formed therein partitioned by a partition wall, wherein a first gas inlet pipe is formed in one side portion of the first passage; a damper which is disposed in the second passage of the housing so as to open or block the flow of the secondary air according to the state of rotation, wherein a damper hole is formed in the damper; a secondary gas inlet pipe having one end portion coupled with the damper, wherein a secondary gas outlet is formed on the same circumference as the damper hole, a secondary gas flows into the other end portion, and the secondary gas outlet and the damper hole selectively communicate with each other according to the angle of rotation of the damper; and a motor for rotating in a coupled state with the damper which is disposed outside

of the housing.

(57) 요약서:

[다음 쪽 계속]

WO 2013/122332 A1



본 발명은 연소기기용 듀얼 벤츄리(dual venturi)에 관한 것으로, 구체적으로는 운수기에 구비되는 버너측 가스 및 공기를 공급하는 양을 2단계로 제어하되, 모터와 댐퍼를 결합하여 모터의 구동에 의하여 댐퍼가 회전됨에 따라 댐퍼가 2차 공기 및 가스의 유입구를 동시에 개방 또는 차단하므로 효율적인 열량 제어가 가능한 연소기기용 듀얼 벤츄리에 관한 것이다. 본 발명은 원통형상의 덕트로서 내부에 격벽에 의해 구획되어 1차통로 및 2차통로가 형성되며, 상기 1차통로의 측부에는 1차가스유입관이 형성된 하우징; 상기 하우징의 2차통로 내에 위치하여 회전 상태에 따라 2차공기의 흐름을 개폐하도록 설치됨과 아울러, 댐퍼공이 형성되는 댐퍼; 일단부가 상기 댐퍼와 결합되고, 댐퍼공과 동일 원주상에 2차가스출구가 형성되며, 타단부에 2차가스가 유입되며, 상기 댐퍼의 회전 각도에 따라서 2차가스출구와 상기 댐퍼공이 선택적으로 연통되는 2차가스유입관 및 상기 하우징의 외측에 회전축이 상기 댐퍼와 결합되어 회전시키는 모터를 포함한다.

【DESCRIPTION】

【Invention Title】

DUAL VENTURI FOR COMBUSTION APPARATUS

【Technical Field】

5 The present invention relates to a dual venturi for a
combustion apparatus, and more particularly, to a dual
venturi for a combustion apparatus, capable of effectively
controlling a heating value since respective amounts of gas
and air supplied to a burner provided in a water heater are
10 controlled in a two-step manner and a motor is coupled to a
damper so that the damper simultaneously opens or closes
inlets for secondary air and gas along with rotation of the
damper by driving of the motor.

【Background Art】

15 In general, combustion apparatuses such as boilers and
water heaters for the purpose of use of heating and hot
water are classified into an oil boiler, a gas boiler, an
electric boiler and a water heater depending on the fuel it
is supplied with, and are variously developed and used
20 according to installation applications.

 In such combustion apparatuses, particularly the gas
boiler and the water heater typically use a bunsen burner or
a premixed burner to burn gas fuel. The premixed burner
among others has a combustion method of mixing gas and air
25 in a mixing ratio for optimal combustion and then supplying

a mixture (air + gas) to a flame hole section so that the mixture is burned.

In addition, the performance of the combustion apparatuses is evaluated as a TDR (Turn-Down Ratio). The TDR refers to "a ratio of maximum gas consumption to minimum gas consumption" in a gas combustion device in which an amount of gas is variably controlled. For example, when the maximum gas consumption is 24,000 kcal/h and the minimum gas consumption is 8,000 kcal/h, the TDR is 3:1. The TDR is constrained by whether flame is stably maintained to some degree under minimum gas consumption.

In the gas boiler and the water heater, convenience for use of heating and hot water is increased as the TDR becomes greater. That is, when the burner is actuated in a region in which the TDR is small (namely, the minimum gas consumption is high) and loads of heating and hot water are small, the combustion apparatuses are frequently turned on/off. For this reason, variation in temperature control is increased and durability of the apparatuses is deteriorated. Thus, in order to improve these problems, various methods for improving the TDR of the burner applied to the combustion apparatuses have been developed.

In such a modulating control burner, valves allowing for supply of gas are mainly classified into an electrical modulating gas valve controlled by current values and a

pneumatic modulating gas valve controlled by differential pressures generated during supply of air.

The pneumatic modulating gas valve controls an amount of gas supplied to the burner by differential pressures generated when air required for combustion is supplied to the burner by a blower. In this case, air and gas required for combustion are mixed in a gas-air mixer and then supplied to the burner in a mixture (air + gas) form.

In the gas-air mixer of the gas burner using the above pneumatic modulating gas valve, the TDR is basically constrained by a factor such as a relation between gas consumption Q and differential pressure ΔP . The relation between flow rate and differential pressure of a fluid is generally as follows.

$$Q = k\sqrt{\Delta P}$$

That is, as seen in the above relational equation, in order to double the flow rate of the fluid, the differential pressure has to be quadrupled.

Accordingly, the ratio of pressure differences has to be defined as 9:1 for defining the TDR as 3:1 and the ratio of pressure differences has to be defined as 100:1 for defining the TDR as 10:1. However, there is a problem in that it is impossible to infinitely increase gas supply pressure.

In order to resolve the problem in which the gas supply pressure may not be infinitely increased, there is disclosed a method which increases the TDR of the gas burner by respectively dividing passages, through which air and gas are supplied, into two or more regions and by opening and closing each passage of gas injected into the burner.

【Disclosure】

【Technical Problem】

The present invention has been made in view of the above problems, and it is an object of the present invention to provide a dual venturi for a combustion apparatus, capable of effectively controlling inflow and outflow of secondary gas and air by allowing a secondary gas passage to be connected to or blocked from a secondary air duct according to a rotation angle of a damper.

【Technical Solution】

In accordance with an aspect of the present invention, a dual venturi for a combustion apparatus includes a housing configured as cylindrical duct, divided therein by a partition wall to have a primary passage and a secondary passage, and having a primary gas inlet pipe formed at a side portion of the primary passage, a damper located within the secondary passage of the housing to open and close a flow of secondary air along with rotation of the damper, the damper being formed with a damper hole, a secondary gas

inlet pipe having one end coupled to the damper and having a secondary gas outlet formed on the same circumference as the damper hole, secondary gas being introduced into the other end of the secondary gas inlet pipe, the secondary gas outlet selectively communicating with the damper hole according to a rotation angle of the damper, and a motor disposed outside the housing and having a rotary shaft coupled to the damper such that the damper is rotated.

In the aspect, the damper and the secondary gas inlet pipe may include an opening and closing unit configured of two or more first protrusion pieces protrudingly formed at an inner side of a central portion of the damper, a moving body moving upward or downward along an inner peripheral surface of the secondary gas inlet pipe along with rotation of the damper, the moving body having second protrusion pieces formed to engage with the first protrusion pieces and a recessed portion formed on an outer peripheral surface thereof so that the secondary gas flows in an inner wall of the secondary gas inlet pipe, a spring for elastically supporting the moving body, and a spring fixing portion coupled to an upper portion of the moving body to support the spring, the spring fixing portion having a recessed portion formed on a circumference thereof so as to form a passage so that the secondary gas flows in the inner wall of the secondary gas inlet pipe, and the flow of the secondary

gas may be blocked when the second protrusion pieces of the moving body engage with the first protrusion pieces.

In the aspect, the moving body may further include a sealing member for sealing a portion coming into contact
5 with the secondary gas inlet pipe.

In the aspect, when the moving body is moved upward by rotation of the damper while the second protrusion pieces and the first protrusion pieces are changed from a position at which respective sides thereof are in contact with each
10 other to a position at which respective tip portions thereof are in contact with each other, the secondary gas may flow between an inner wall surface of the secondary gas inlet pipe and the recessed portions formed at the moving body and the spring fixing portion.

15 In the aspect, the motor may be a synchronous motor.

【Advantageous Effects】

In accordance with the present invention having the above features, the following effects may be obtained.

20 First, heating values such as low heating values or high heating values may be selectively generated by a water heater as necessary and a user may control the heating values such as low heating values or high heating values as necessary. Therefore, fuel costs may be reduced.

25 Secondly, an inner portion of a housing is divided by a partition wall to form a primary passage and a secondary

passage so that only primary air and gas flow in the primary passage and only secondary air and gas flow in the secondary passage. Therefore, it may be possible to easily adjust a TDR by regulating the flows of air and gas in the secondary
5 passage.

Thirdly, since a damper opens and closed a secondary gas outlet and simultaneously opens and closes the secondary passage along with rotation thereof, a structure may be significantly simplified.

10 **【Description of Drawings】**

FIG. 1 is a perspective view illustrating a dual venturi for a combustion apparatus according to an embodiment of the present invention.

FIG. 2 is a cross-sectional view taken along line A-A
15 and illustrates a state in which a damper closes a secondary passage.

FIG. 3 is a cross-sectional view illustrating a state in which the damper opens the secondary passage in FIG. 2.

FIG. 4 is a cross-sectional view illustrating a state
20 in which an opening and closing unit provided in a secondary gas inlet pipe blocks the secondary passage in FIG. 2.

FIG. 5 is a cross-sectional view illustrating a state in which the secondary passage is opened by rotation of the opening and closing unit in FIG. 4.

25 FIG. 6 is a perspective view illustrating the damper of

FIG. 4.

FIG. 7 is a perspective view illustrating a spring fixing portion of the opening and closing unit in FIG. 4.

FIG. 8 is a perspective view illustrating a moving body
5 of the opening and closing unit in FIG. 4.

【Mode for Invention】

Reference will now be made in detail to embodiments of the present invention, examples of which are illustrated in the accompanying drawings. The present invention may,
10 however, be embodied in different forms and should not be construed as limited to the embodiments set forth herein. Rather, these embodiments are provided so that this disclosure will be thorough and complete, and will fully convey the scope of the present invention to those skilled
15 in the art. Accordingly, the drawings are not necessarily to scale and in some instances, proportions may have been exaggerated in order to clearly illustrate features of the embodiments. Throughout the disclosure, like reference numerals refer to like parts throughout the various figures
20 and embodiments of the present invention. In addition, detailed descriptions of functions and constructions well known in the art may be omitted to avoid unnecessarily obscuring the gist of the present invention.

Hereinafter, a dual venturi for a combustion apparatus
25 according to an exemplary embodiment of the present

invention will be described in detail with reference to the accompanying drawings.

FIG. 1 is a perspective view illustrating a dual venturi for a combustion apparatus according to an embodiment of the present invention. FIG. 2 is a cross-sectional view taken along line A-A and illustrates a state in which a damper closes a secondary passage. FIG. 3 is a cross-sectional view illustrating a state in which the damper opens the secondary passage in FIG. 2. FIG. 4 is a cross-sectional view illustrating a state in which an opening and closing unit provided in a secondary gas inlet pipe blocks the secondary passage in FIG. 2. FIG. 5 is a cross-sectional view illustrating a state in which the secondary passage is opened by rotation of the opening and closing unit in FIG. 4. FIG. 6 is a perspective view illustrating the damper of FIG. 4. FIG. 7 is a perspective view illustrating a spring fixing portion of the opening and closing unit in FIG. 4. FIG. 8 is a perspective view illustrating a moving body of the opening and closing unit in FIG. 4.

Referring to FIGS. 1 to 8, the dual venturi for a combustion apparatus according to the embodiment of the present invention includes a housing 100 which is divided by a partition wall 101 to have a primary passage 110 and a secondary passage 120 and has a primary gas inlet pipe 130

formed at a middle on a side wall of the primary passage 110.

The secondary passage 120 of the housing 100 is provided with a damper 301 which is provided therein to open and close the flow of secondary air when the damper 301 is rotated and is formed with a damper hole 303. The damper 301 is coupled to a secondary gas inlet pipe 330 and the secondary gas inlet pipe 330 passes through a middle portion of the housing 100 to be coupled with the damper 301. In addition, the secondary gas inlet pipe 330 has a secondary gas outlet 302 formed at an end thereof and the secondary gas outlet 302 is formed to be located on the same line as the damper hole 303.

Accordingly, the secondary gas outlet 302 has a structure of communicating with the damper hole 303 according to a rotation angle of the damper 301.

Meanwhile, the housing 100 is further provided, at an outer side thereof, with a motor 180 for rotating the damper 301 by coupling of a rotary shaft 181 and the damper 301. The motor 180 provides torque to the damper 301. The rotary shaft 181 has protrusions 182 formed at intervals of 90 degrees and the protrusions 182 operate a limit switch 201 along with rotation of the motor 180 such that the rotation angle of the damper 301 is controlled. The limit switch 201 is provided inside a switch box 200 and the switch box 200 is interposed between the housing 100 and the motor 180.

Meanwhile, the damper 301 has first protrusion pieces 401 which are protrudingly formed at an inner side of a central portion thereof. The first protrusion pieces 401 are symmetrically formed at a distal end of a cylindrical member 402 formed integrally with the damper 301.

In addition, the secondary gas inlet pipe 330 is coupled with a moving body 410 having recessed portions 412 which are formed on an outer peripheral surface thereof so as to correspond to the first protrusion pieces 401. The moving body 410 has second protrusion pieces 411 formed to engage with the first protrusion pieces 401. Accordingly, when the first protrusion pieces 401 engage with the second protrusion pieces 411, a cylindrical shape without a gap is formed.

The first and second protrusion pieces 401 and 411 are formed in the same shape, and cross-sectional portions thereof have a flexible curved surface such that the first and second protrusion pieces 401 and 411 are easily coupled to and decoupled from each other.

Meanwhile, an upper portion of the moving body 410 is coupled with a spring fixing portion 430 which has a recessed portion 412 formed on an outer peripheral surface thereof and is screw-coupled to the secondary gas inlet pipe 330. A spring 420 is interposed between the moving 410 and the spring fixing portion 430 so as to elastically support

the moving body 410.

In addition, the moving body 410 is further provided with a sealing member 440 for sealing a portion coming into contact with the secondary gas inlet pipe 330. The portion
5 at which the moving body 410 comes into contact with the secondary gas inlet pipe 330 is formed in a stepped shape, and the sealing member 440 is coupled to the stepped portion.

Hereinafter, an operation state of the dual venturi for a combustion apparatus of the present invention having the
10 above configuration will be described.

First, an operation in which only primary gas and air are supplied from a water heater is performed in such a way that only the primary air introduced into the primary passage 110 and the primary gas introduced into the primary
15 gas inlet pipe 130 are mixed and then introduced into a turbofan (not shown) via the primary passage, as shown in FIGS. 2 and 4. Here, the damper 301 closes the secondary passage 120 to block air. In addition, the moving body 410 is pressed against the sealing member 440 while the first
20 protrusion pieces 401 engage with the second protrusion pieces 411 of the moving body 410 so that the secondary gas outlet 302 does not communicate with the damper hole 303. As a result, secondary gas is not introduced into the secondary passage 120.

25 Accordingly, since a mixture of air and gas is

introduced into the turbofan only through the primary passage 110, a combustion apparatus may be actuated by means of a low heating value.

Meanwhile, in order to actuate the combustion apparatus
5 by means of a high heating value, power is applied to the motor 180 and the motor 180 rotates the damper 301 by 90 degrees such that the damper 301 corresponds to an air flow direction in the secondary passage 120, as shown in FIGS. 3 and 5.

10 In this case, since the first protrusion pieces 401 are also rotated during rotation of the damper 301, the engagement between the first and second protrusion pieces 401 and 411 is released by rotation of the first protrusion pieces 401 and thus the moving body 410 is moved upward.
15 Consequently, since respective tip portions of the first and second protrusion pieces 401 and 411 are in contact with each other and the secondary gas outlet 302 and the damper hole 303 are located at the same position to communicate with each other, secondary gas is introduced into the
20 secondary passage 120.

Here, as shown in FIG. 5, the secondary gas is introduced through the secondary gas inlet pipe 330 and through the respective recessed portions 412 and 432 formed on the outer peripheral surfaces of the spring fixing
25 portion 430 and the moving body 410, and then passes through

the secondary gas outlet 302 and the damper hole 303 (as indicated by a dotted arrow), so as to be introduced into the secondary passage 120.

Thus, the secondary gas is mixed with the air and gas introduced through the primary passage 110 and the primary gas inlet pipe 130 so that a large amount of mixture is generated and the mixture is introduced into the turbofan. As a result, the combustion apparatus may be actuated by means of a high heating value.

Subsequently, when the motor 180 rotates the damper 301 by 90 degrees in order to actuate the combustion apparatus by means of a low heating value again, the damper 301 is returned to the state shown in FIGS. 2 and 4. Consequently, the secondary passage 120 and the secondary gas outlet 302 are blocked and, as such, the combustion apparatus is actuated by means of a low heating value. Here, the spring 420 interposed between the moving body 410 and the spring fixing portion 430 serves to block the secondary gas from being introduced by moving the moving body 410 toward the damper 301 using restoring force of the spring 420 when the damper 301 is rotated to close the secondary gas outlet 302 and by pressing the outer surface of the moving body 410 against the sealing member 440.

Hereinafter, a description will be given with respect to the limit switch 201 for controlling rotation of the

motor 180 driving the damper such that the combustion apparatus is actuated by means of the low heating value or the high heating value.

The rotary shaft 181 of the motor 180 has the protrusions 182 which are protrudingly formed on an outer peripheral surface thereof at intervals of 90 degrees and the limit switch 201 has movable protrusions 202 formed to be located on the same circumference as the protrusions 182. When the protrusions 182 press the movable protrusions 202 while rotating at intervals of 90 degrees, the limit switch 201 causes a short circuit current and, as such, rotation of the motor 180 is stopped.

Therefore, when the combustion apparatus is actuated, the protrusions 182 are rotated by 90 degrees to press the movable protrusions 202. Then, the limit switch 201 is turned off to stop rotation of the motor 180 and the damper 301 is also stopped. As a result, the secondary passage 120 is opened or closed.

Although the present invention has been described with respect to the illustrative embodiments of the dual venturi for a combustion apparatus, it should be understood that numerous other modifications and applications may be devised by those skilled in the art that will fall within the intrinsic aspects of the embodiments. More particularly, various variations and modifications are possible in

concrete constituent elements of the embodiments. In addition, it is to be understood that differences relevant to all variations, equivalents, and alternatives fall within the spirit and scope of the present disclosure defined in
5 the appended claims.

[Description of Reference Numerals]

100: housing, 101: partition wall

110: primary passage, 120: secondary passage

130: primary gas inlet pipe, 180: motor

10 181: rotary shaft, 182: protrusion

200: switch box, 201: limit switch

202: movable protrusion, 301: damper

302: secondary gas outlet, 303: damper hole

330: secondary gas inlet pipe, 401: first protrusion

15 piece

402: cylindrical member, 410: moving body

411: second protrusion piece, 412: recessed portion

420: spring, 430: spring fixing portion

432: recessed portion, 440: sealing member

20

【CLAIMS】

1. A dual venturi for a combustion apparatus, comprising:

a housing (100) configured as cylindrical duct, divided
5 therein by a partition wall (101) to have a primary passage (110) and a secondary passage (120), and having a primary gas inlet pipe (130) formed at a side portion of the primary passage (110);

a damper (301) located within the secondary passage
10 (120) of the housing (100) to open and close a flow of secondary air along with rotation of the damper (301), the damper (301) being formed with a damper hole (303);

a secondary gas inlet pipe (330) having one end coupled
to the damper (301) and having a secondary gas outlet (302)
15 formed on the same circumference as the damper hole (303), secondary gas being introduced into the other end of the secondary gas inlet pipe (330), the secondary gas outlet (302) selectively communicating with the damper hole (303) according to a rotation angle of the damper (301); and

a motor (180) disposed outside the housing (100) and
20 having a rotary shaft (181) coupled to the damper (301) such that the damper (301) is rotated.

2. The dual venturi of claim 1, wherein the damper
25 (301) and the secondary gas inlet pipe (330) comprise:

two or more first protrusion pieces (401) protrudingly formed at an inner side of a central portion of the damper (301);

a moving body (410) moving upward or downward along an inner peripheral surface of the secondary gas inlet pipe (330) along with rotation of the damper (301), the moving body (410) having second protrusion pieces (411) formed to engage with the first protrusion pieces (401) and a recessed portion (412) formed on an outer peripheral surface thereof so that the secondary gas flows in an inner wall of the secondary gas inlet pipe (330);

a spring (420) for elastically supporting the moving body (410); and

a spring fixing portion (430) coupled to an upper portion of the moving body (410) to support the spring (420), the spring fixing portion (430) having a recessed portion (432) formed on a circumference thereof so as to form a passage so that the secondary gas flows in the inner wall of the secondary gas inlet pipe (330), and

wherein the flow of the secondary gas is blocked when the second protrusion pieces (411) of the moving body (410) engage with the first protrusion pieces.

3. The dual venturi of claim 2, wherein the moving body (410) further comprises a sealing member (440) for

sealing a portion coming into contact with the secondary gas inlet pipe (330).

4. The dual venturi of claim 1 or 2, wherein when the
5 moving body (410) is moved upward by rotation of the damper
(301) while the second protrusion pieces (411) and the first
protrusion pieces (401) are changed from a position at which
respective sides thereof are in contact with each other to a
position at which respective tip portions thereof are in
10 contact with each other, the secondary gas flows between an
inner wall surface of the secondary gas inlet pipe (330) and
the recessed portions (412, 432) formed at the moving body
(410) and the spring fixing portion (430).

15 5. The dual venturi of claim 1, wherein the motor
(180) is a synchronous motor.

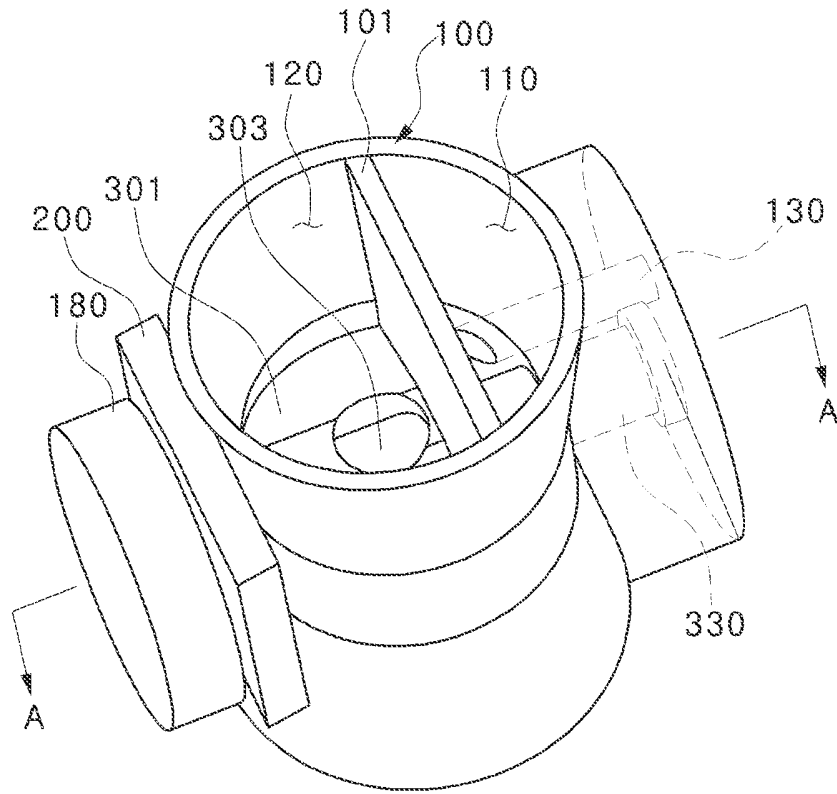

FIGURE 1

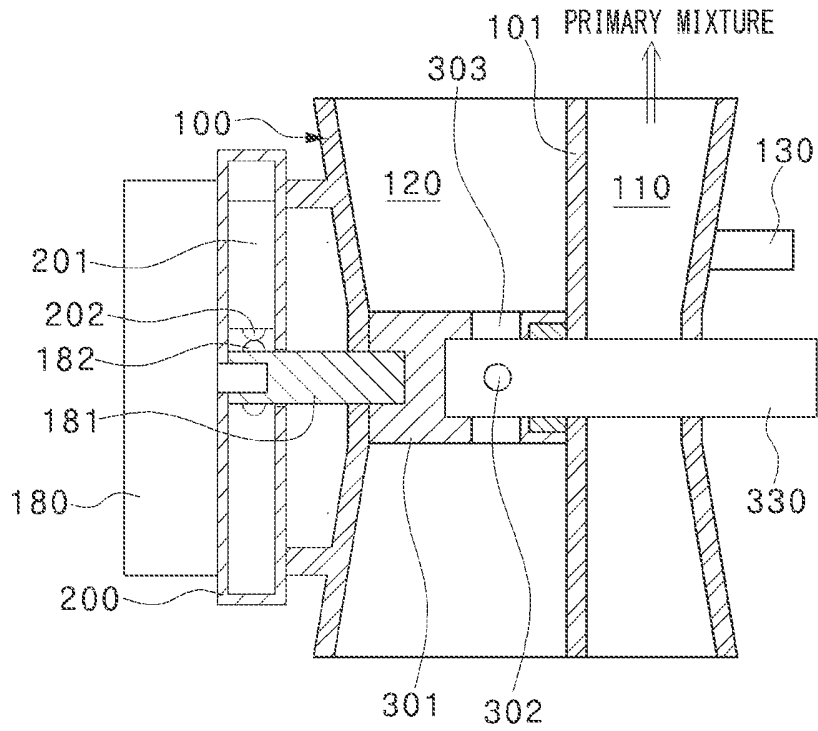

FIGURE 2

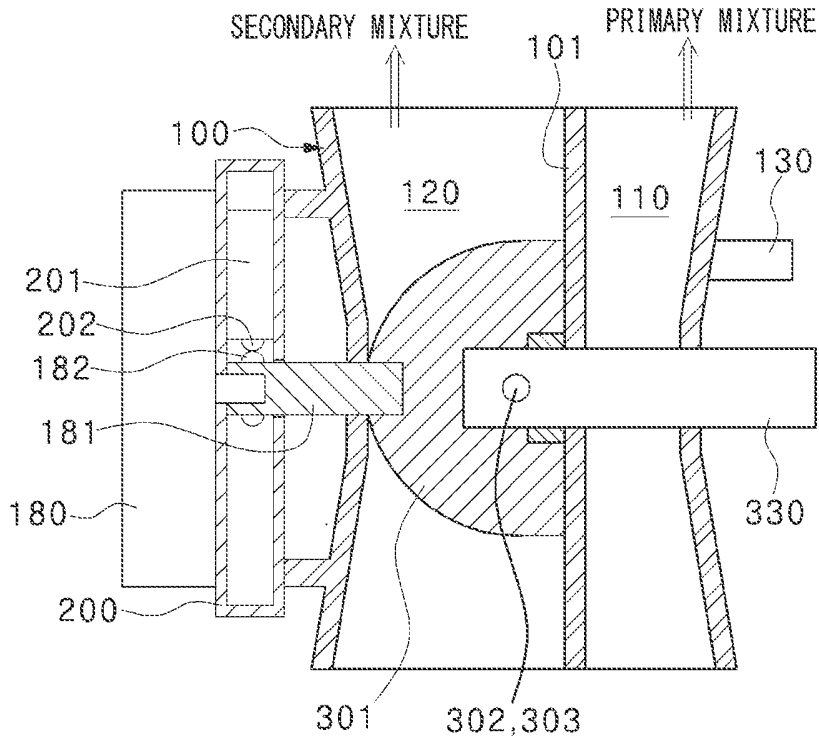

FIGURE 3

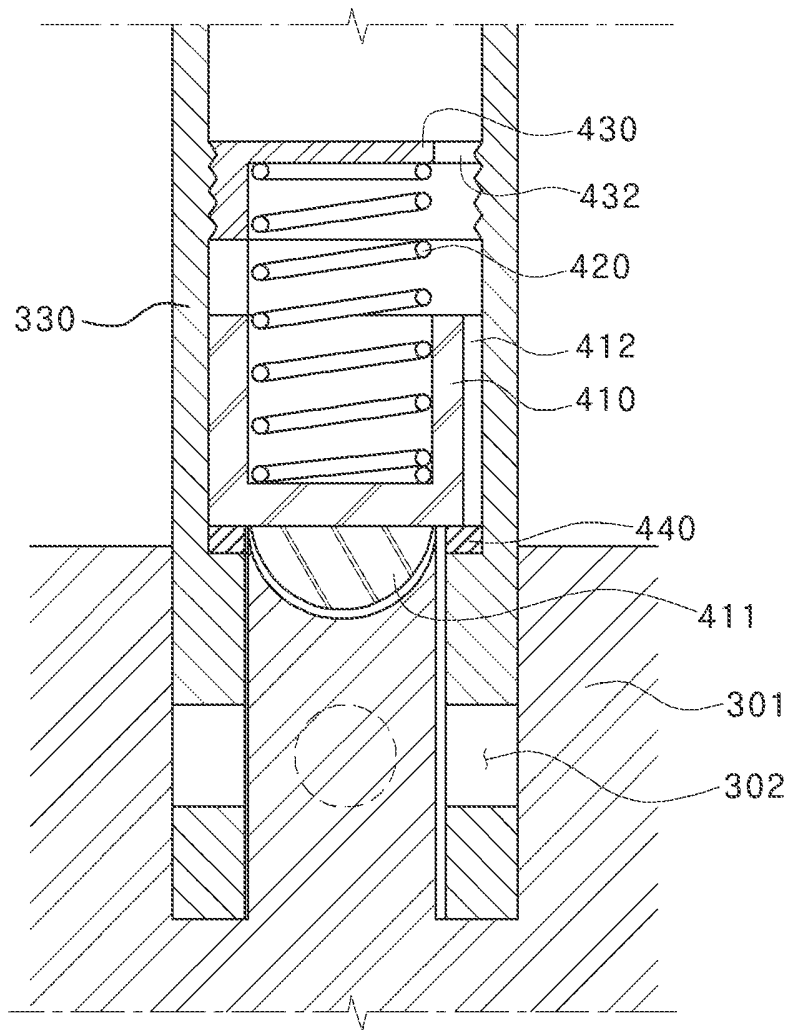

FIGURE 4

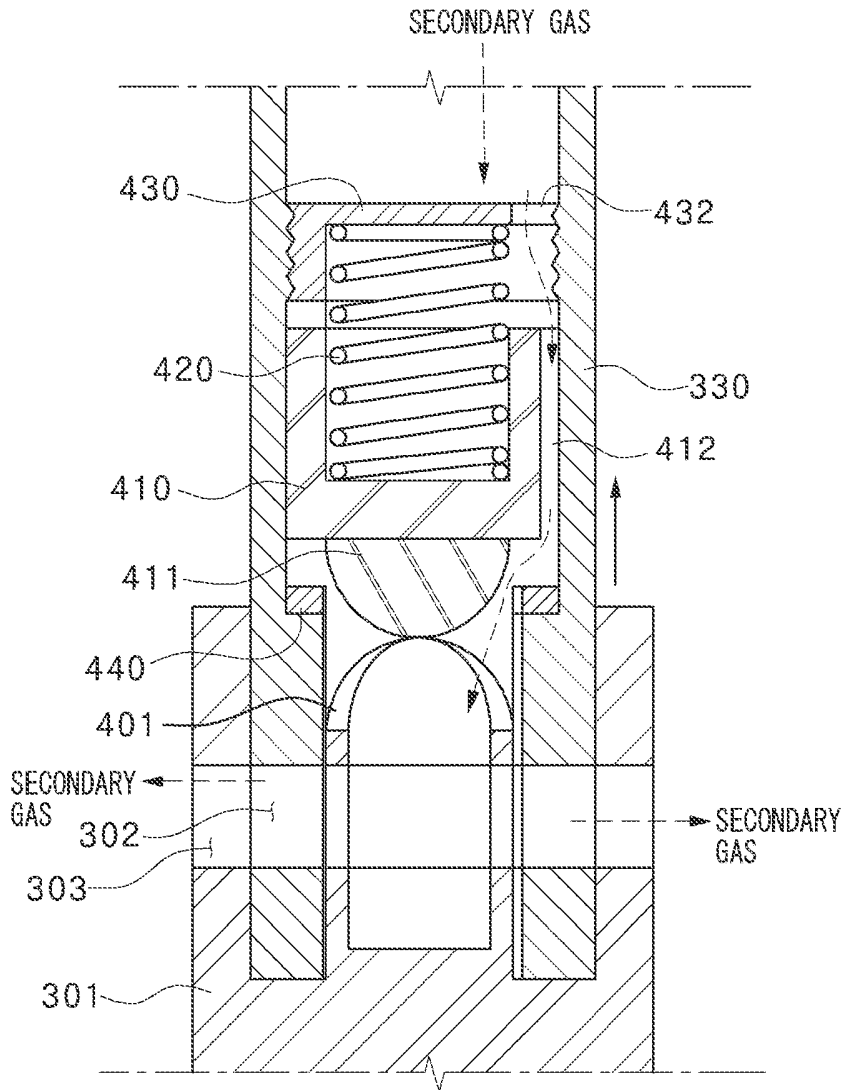

FIGURE 5

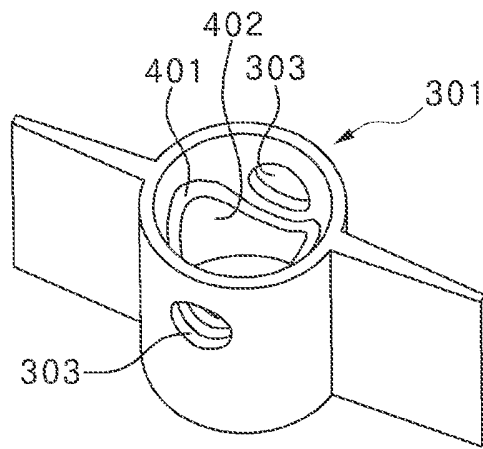

FIGURE 6

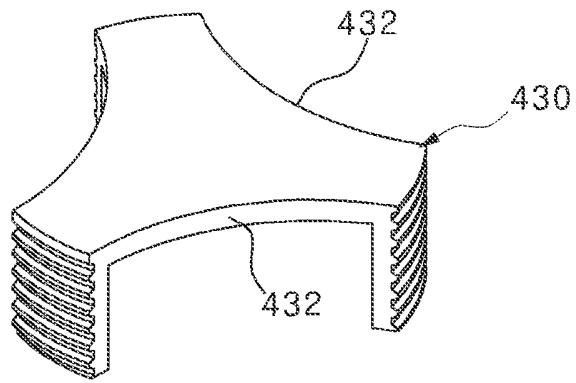

FIGURE 7

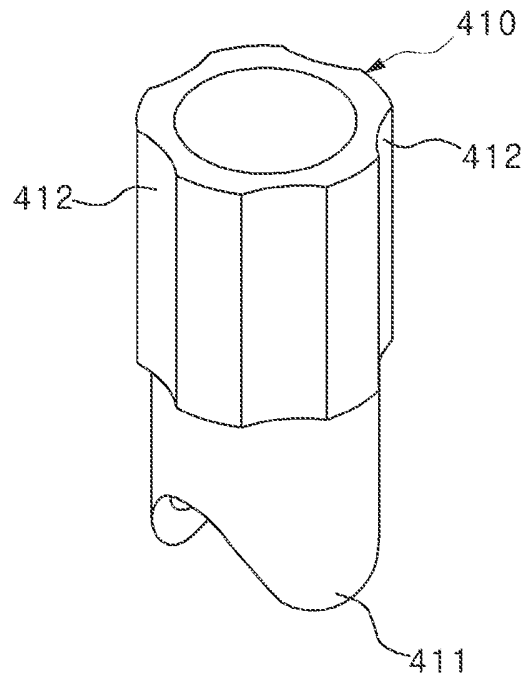

FIGURE 8