

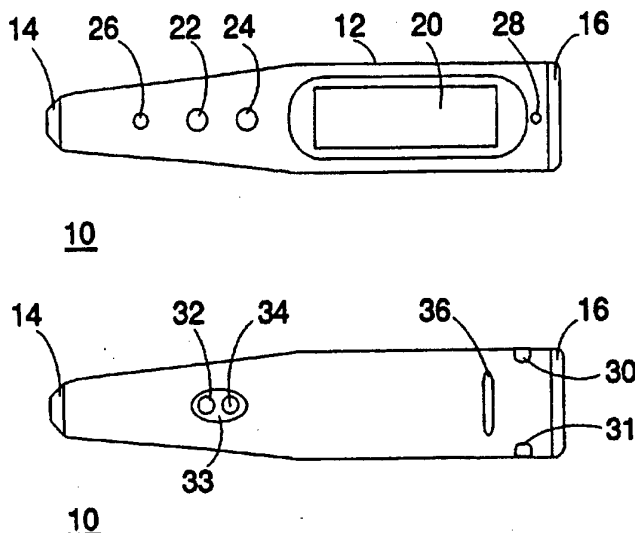

## INTERNATIONAL APPLICATION PUBLISHED UNDER THE PATENT COOPERATION TREATY (PCT)

<p>(51) International Patent Classification <sup>6</sup> : <b>G06K 7/10, 17/00</b></p>	<p><b>A1</b></p>	<p>(11) International Publication Number: <b>WO 95/10818</b> (43) International Publication Date: 20 April 1995 (20.04.95)</p>
<p>(21) International Application Number: PCT/GB94/02101 (22) International Filing Date: 27 September 1994 (27.09.94) (30) Priority Data: 9321133.2 13 October 1993 (13.10.93) GB (71) Applicant (for all designated States except US): DATAQUILL LIMITED [-/-]; P.O. Box 3151, Skelton Buildings, Road Town, Tortola (VG). (72) Inventors; and (75) Inventors/Applicants (for US only): CALLAGHAN, Francis, John [GB/-]; Eulah, Mont Couchon, St. Helier, Jersey (GB). DORAN, Paul, Marshall [GB/-]; Haut-Clair, Bellozane Road, St. Helier, Jersey (GB). ROBB, Gary, Douglas [CA/-]; 20 Close Nicole, Mont Les Vaux, St. Brelade, Jersey (GB). (74) Agent: HARRIS, Ian, Richard; D. Young &amp; Co., 21 New Fetter Lane, London EC4A 1DA (GB).</p>		<p>(81) Designated States: AM, AT, AU, BB, BG, BR, BY, CA, CH, CN, CZ, DE, DK, EE, ES, FI, GB, GE, HU, JP, KE, KG, KP, KR, KZ, LK, LR, LT, LU, LV, MD, MG, MN, MW, NL, NO, NZ, PL, PT, RO, RU, SD, SE, SI, SK, TJ, TT, UA, US, UZ, VN, European patent (AT, BE, CH, DE, DK, ES, FR, GB, GR, IE, IT, LU, MC, NL, PT, SE), OAPI patent (BF, BJ, CF, CG, CI, CM, GA, GN, ML, MR, NE, SN, TD, TG), ARIPO patent (KE, MW, SD, SZ).</p> <p><b>Published</b> <i>With international search report.</i></p>

(54) Title: DATA ENTRY SYSTEMS



## (57) Abstract

A data entry system includes a hand held data entry unit having a reading sensor for sensing commands and/or data, rewritable storage for storing information relating to selectable items, a controller (a microprocessor or other processing circuitry) and a display screen for displaying a user readable representation of the commands and/or stored information for a selected item, and a telecommunication interface for the telephonic transmission of information relating to a selected item or items the storage to a remote processing centre and for the telephonic transmission of information relating to selectable items from the remote processing centre to the storage. Preferably a telecommunications interface is provided in the hand held unit for cellular or other wireless telephony system. The hand held unit can be configured to combine the data entry functions with those of audio telephony.

**FOR THE PURPOSES OF INFORMATION ONLY**

Codes used to identify States party to the PCT on the front pages of pamphlets publishing international applications under the PCT.

AT	Austria	GB	United Kingdom	MR	Mauritania
AU	Australia	GE	Georgia	MW	Malawi
BB	Barbados	GN	Guinea	NE	Niger
BE	Belgium	GR	Greece	NL	Netherlands
BF	Burkina Faso	HU	Hungary	NO	Norway
BG	Bulgaria	IE	Ireland	NZ	New Zealand
BJ	Benin	IT	Italy	PL	Poland
BR	Brazil	JP	Japan	PT	Portugal
BY	Belarus	KE	Kenya	RO	Romania
CA	Canada	KG	Kyrgyzstan	RU	Russian Federation
CF	Central African Republic	KP	Democratic People's Republic of Korea	SD	Sudan
CG	Congo	KR	Republic of Korea	SE	Sweden
CH	Switzerland	KZ	Kazakhstan	SI	Slovenia
CI	Côte d'Ivoire	LI	Liechtenstein	SK	Slovakia
CM	Cameroon	LK	Sri Lanka	SN	Senegal
CN	China	LU	Luxembourg	TD	Chad
CS	Czechoslovakia	LV	Latvia	TG	Togo
CZ	Czech Republic	MC	Monaco	TJ	Tajikistan
DE	Germany	MD	Republic of Moldova	TT	Trinidad and Tobago
DK	Denmark	MG	Madagascar	UA	Ukraine
ES	Spain	ML	Mali	US	United States of America
FI	Finland	MN	Mongolia	UZ	Uzbekistan
FR	France			VN	Viet Nam
GA	Gabon				

DATA ENTRY SYSTEMS

This invention relates to data entry systems, to applications of such data entry systems and to equipment for use therewith.

5 UK patent GB-B-2,202,664 describes an example of an application for a data entry system for the automated ordering of merchandisable items. Merchandisable items are represented in a printed catalogue or other form of list and are associated with bar codes. A merchandise ordering unit comprises a bar code reader with a telephone transmission  
10 capability for use in selecting one or more items from the catalogue and transmitting electronically an order for the merchandise to a processing centre over the public telephone network. The orders for the merchandisable items received in this way are processed in the processing centre. As described, the hand held data entry terminal  
15 comprises a calculator-like processing unit with a pen-like bar code reader wand electrically connected to the processing unit via a flexible cable. The processing unit includes a display for displaying information and a telephone transmission capability for transmitting captured data via the telephone network. Although this system works  
20 well, it is rather bulky and can be somewhat inconvenient in use as it requires two handed operation, one hand for the processing unit and one hand for the wand. Alternatively, if the processing unit is not carried all the time, it needs to be located in a position where the display on the processing unit can be seen and the keys on the  
25 processing unit can be operated. It will be appreciated that particularly where the processing unit is being carried in the hand, operation of the keys on it while holding the wand requires considerable dexterity.

European patent application EP-A-0,094,571 describes a self-  
30 contained portable data entry terminal positioned within a portable wand-type enclosure. The wand contains a bar code optical reader, signal conditioning electronics, a microprocessor, a memory and a rechargeable battery. The optical reader is operable as a transmitter/receiver so that readout of data stored in the memory is  
35 possible. An example of the use of the portable data terminal is described in which captured bar code data can be output from the memory via the optical reader to an optical receiver and from there via an

audio coupler to a telephone line for transmission to a remote station. Another example is described where the bar code data relates to items on a menu in a restaurant. Captured menu selections can be output from the memory via the optical reader to an optical receiver and from there  
5 via a computer to a printer in a kitchen. Also described is the programming of the portable data entry terminal using an optical transmitter to input data via the optical reader. The wand includes a beeper for indicating the correct reading of a bar code and the current memory loading. The wand described in EP-A-0,094,571 is relatively  
10 simple in construction, and although it is readily portable, it does not provide any confirmation of what has been read.

A further portable data entry terminal manufactured by Telxon Corporation is described in an article entitled "Telxon Corporation, Portable Data Collection and Entry Systems" published by McGraw-Hill in  
15 1989 and referenced "R51-832-101 SKU/UPC Marking and Reading Equipment". The article describes various models of data entry terminals similar to that described in UK patent GB-B-2,202,664. Data from the terminals can be transmitted to a remote station via various telecommunication options including direct connect modems and acoustic  
20 couplers. The data entry terminals have a generally rectangular format, similar to a large scientific calculator, with a rectangular display and an array of keys. For most models, a separate bar code reader wand is provided which is connected to the data entry terminal via a flexible cable, requiring a two-handed operation as described  
25 above. One model PTC-620 has the same basic format as the other terminals, but is described as being for simple applications and features a snap-on reversible head for one-handed operation with either the left or the right hand. However, this terminal is still relatively bulky and cumbersome and in use it is easy inadvertently to operate one  
30 or more keys in the array of keys.

An object of the present invention is to provide a data entry system which mitigates the problems of the prior art.

In accordance with an aspect of the invention, there is provided a data entry system comprising a hand held data entry unit, the hand  
35 held unit comprising a reading sensor for sensing commands and/or data and for producing input signals in response to the sensed commands and/or data, rewritable storage for information relating to selectable

items, a controller connected to receive and process the input signals from the sensor for responding to the commands to control the hand held unit and/or to the data to select the item and a display screen for displaying a user readable representation of the commands and/or stored  
5 information for the selected item, and a telecommunications interface for telephonic transmission of information relating to a selected item or items from the storage to a remote processing centre and for telephonic transmission of information relating to selectable items from the remote processing centre to the storage.

10 The provision of a hand held unit having an integral sensor, control, storage, display means with a telecommunications interface enables the unit to be used in a particularly efficient and self-contained manner for the capture, processing, storage, display and  
15 unit enables the user to verify the data being captured without taking his or her eyes off the areas in which data capture is taking place.

Preferably, the telecommunications interface is integral to the hand held unit. The provision of a telecommunications interface in the hand held unit enables captured data to be used for direct telephonic  
20 transmission of the captured data via a telephone network to a remote processing centre. It also allows for data and/or commands to be received from the remote data processing centre.

Preferably, the hand held unit includes a rechargeable power source. There can be provided a base unit separate from the hand held  
25 unit, wherein the base unit includes a charger unit and the base unit and the hand held unit are provided with respective interconnectable electrical connectors for recharging the rechargeable power source.

In some embodiments of the invention, the data entry system can comprise a base unit separate from the hand held unit, wherein the base  
30 unit and the hand held unit are provided with a wireless data link which is operable for bidirectional data transfer between the hand held unit and the base unit, and wherein the base unit includes a telecommunications interface for telephonic transmission of information relating to a selected item or items from the storage to a remote  
35 processing centre and for telephonic transmission of information relating to selectable items from the remote processing centre to the storage. In this embodiment, the wireless data link preferably

comprises, in the base unit and the hand held unit, optical transmitters and/or receivers which cooperate when the hand held unit is in the rest position to provide a two way optical data link for transferring data from the hand held unit to the base unit and/or from  
5 the base unit to the hand held unit. In other embodiments it could comprise respective radio frequency, rather than optical, transmitters and receivers, or indeed other types of transmitters and receivers.

In preferred embodiments of the invention, the telecommunications interface is an interface for connection to a wireless telephony  
10 network. This provides for a particularly advantageous implementation of the invention, which can then be used without the need to plug in the data entry system to, for example, a conventional wired telephone network.

In a preferred embodiment of the invention the telecommunications  
15 interface is a cellular telephone network interface. In this embodiment of the invention, particularly where the telecommunications interface is incorporated in the hand held unit, the data entry system can be used with the convenience, for example, of a portable cellular phone. Cellular telephone networks are now common place and give a  
20 very wide area of coverage. This facilitates the use of a data entry system in accordance with the invention in, for example, a user's home or workplace.

Alternatively, the telecommunications interface can be a  
25 satellite telephone network interface, or some other form of wireless telephone interface, for example a telephone interface for a telephone network based on highly localised transponder stations.

Where the telecommunications interface is intended to interface with an analogue telephone network, the telecommunications interface includes a modem.

30 By arranging that the reading sensor can be used for the input of commands for controlling the hand held unit, the number of user input means (e.g., keys) can be kept to a minimum, reducing the possibility of inadvertent operation. Preferably, there are provided one or two manually operable switches for scrolling the display in a first and/or  
35 second direction for selectively displaying a plurality of data stored in the storage. The scrolling of the display enables a large number of items to be accessed with a relatively compact display. In a preferred

embodiment of the invention, the first and/or second switches are the only switches on the hand held unit. Preferably also, operation of the first and/or second switches in predetermined operational states of the hand held unit causes predetermined functions other than scrolling  
5 functions to be performed (e.g., powering-up or powering-down of the hand held unit). By the provision of only two keys on the hand held unit, the possibility of accidentally operating an incorrect key can be reduced, and also the hand held unit can be kept particularly compact.

Preferably, the hand held unit comprises a sensor for reading  
10 coded data, the controller being arranged to access the stored information for selectable items to determine natural language characters or images corresponding to the coded data for display. The invention finds particular, but not exclusive application to the reading of bar codes and/or binary dot codes, whereby the sensor is a  
15 bar code and/or dot code reader. It will be appreciated that the invention also applies to other forms of codes.

The hand held data entry unit may comprise a reading head including a reading sensor for producing input signals, wherein the reading sensor traces movements of the reading head and wherein the  
20 controller is responsive to signals from the sensor representative of the movements for identifying characters traced by the reading head as captured data. In this manner data entry can be made in an advantageous manner by tracing out the characters of the data to be input or characters representing commands for controlling the operation  
25 of the data entry system.

Preferably, the controller is user programmable to cause the captured data to be displayed on the display either in a first orientation suitable for reading displayed data when the hand held unit is held in a user's right hand, or in a second orientation suitable for  
30 reading displayed data when the hand held unit is held in a user's left hand. In a preferred embodiment the display has a substantially rectangular display screen with a longitudinal axis arranged substantially parallel to a longitudinal axis of the hand held unit. For example, for right handed operation, a string of characters could,  
35 for example, be displayed along the display from an end nearest to the sensor to the end furthest therefrom, whereas for left handed operation, the same string of characters would be displayed from the

end of the display furthest from the sensor to the end nearest thereto.

A data entry system comprising a hand held unit with or without a base unit as described above, can also include means for displaying a plurality of selectable items with associated data sources for user selection of an item by operation of the hand held unit and a remote processing centre for processing user selections transmitted from the hand held unit. The controller in the hand held unit is preferably arranged to respond to appropriate commands input, for example via the reading sensor, to issue coded instructions via the telecommunications interface to the data processing centre and to receive programming data (e.g., relating to information for selectable items) from the programming centre for storage in the hand held unit.

The data entry system may additionally be arranged to provide the functions of a telephone to permit audio communication. In particular, if a cellular telephone interface is provided in a hand held unit, this unit can advantageously combine the functions of the data entry unit and a cellular telephone.

Accordingly, the invention also provides a data entry system additionally comprising means for displaying a plurality of selectable items with associated data sources for user selection of an item by operation of the hand held unit and a remote processing centre for processing user selections transmitted from the hand held unit. Preferably, the hand held unit is programmable remotely from the processing centre.

In a preferred embodiment of the invention, the hand held unit is configured as an elongate unit such that it may be held by a user in the manner of a pen or quill with the reading sensor being located in a reading head at or adjacent to one end of the hand held unit. The configuration of the hand held unit such that it may be held in the manner of a pen or quill means that the unit can be held in a familiar and comfortable manner. Also, it facilitates the provision of user input means (e.g. switches) on the hand held unit to be located such that inadvertent operation thereof can easily be avoided.

Preferably the reading sensor is located in a reading head which is releasably attached to the hand held unit. This enables alternative types of reading head to be connected to the hand held unit and/or for faulty reading heads to be replaced easily.



The invention also provides a merchandising system comprising a data entry system of this type wherein the selectable items are merchandisable items and the remote processing centre initiates processing of user orders of the selectable merchandisable items.

5 Thus, a data entry system in accordance with the invention, especially a data entry system comprising a hand held unit including a telecommunications interface for use with a wireless telephony system, such as a cellular network telephone system, provides a particularly advantageous device for use, for example, for "home shopping". It  
10 enables the user to make shopping selections from a catalogue or from a series of options displayed on a television screen from the comfort of his or her home without the need to connect the device to a conventional telephone network. A hand held unit including a wireless telephone network interface such as a cellular network interface finds  
15 particular application where the user of the system is travelling from place to place and may need to perform data entry functions when they are far from a conventional wired telephone network socket.

A data entry system or a merchandising system as described above preferably includes a verification device in the form of a verification  
20 card (e.g., a credit, payment or other validation card) or like carrier carrying a verification bar code and/or dot code for verification of a user identity. Operation of the data entry system subsequent to an initial data capture operation can then be made dependent on the identification of authorised coded data.

25 The invention also provides a carrier for a plurality of data and/or command codes (e.g., bar and/or dot codes) for association with means for displaying a plurality of selectable items in a data entry system or a merchandising system as defined above, wherein the carrier carries a plurality of codes, each for a respective one of a plurality  
30 of natural language and/or numeric characters, and a plurality of commands for controlling the operation of the data entry or merchandising system, each code being associated with a visual representation of the corresponding natural language or numeric character or command and/or of a graphical representation thereof.  
35 This avoids the need for a complete coded data source to be associated with each selectable item in, for example, a catalogue, rather a composite code can be built up by capturing a desired sequence of

individual codes. By including the command characters as well, the need for a lot of keys on the data entry device can be avoided.

As an alternative to the use of bar codes, other data representations could be used. Indeed, if the data entry device is provided with a reading sensor in the form of a camera or other scanning sensor rather than a bar code reader, and the data entry device is provided with character or image recognition logic, graphical or alphanumeric data representations can be captured directly. One application of an embodiment of the pen with a camera head as its sensor could be for fingerprint recognition.

As an example of a possible mode of operation, a command character (e.g., a bar code) can be read using the reading head (e.g., a bar code reading head) and this can be used to load down remote data from a remote station. This is particularly advantageous mode of operation where the data entry system can set up a telephone connection to the remote station automatically, for example where the data entry device has cellular telephone capabilities.

The carrier is preferably in the form of a sheet of material. The various characters and commands could be arranged in the manner of a standard typewriter keyboard layout to facilitate entry of individual codes to make up a desired code sequence (e.g., for a specific product code).

Exemplary embodiments of the invention will be described hereinafter, by way of example only, with reference to the accompanying drawings in which like reference numerals are used for like features and in which:

Figures 1A and 1B are schematic views of a substantially pen-shaped hand held data entry device.

Figure 2 is a schematic plan view of a base unit for use with the hand held unit of Figures 1A and 1B;

Figure 3 is a schematic block diagram of the functional elements of a first example of a hand held data entry device as shown in Figures 1A and 1B;

Figure 4 is a schematic block diagram of the functional elements of a base unit as shown in Figure 2 for use with the hand held data entry device of Figures 1A, 1B and 3;

Figure 5 is an overview of a merchandising system using a data

entry terminal such as is illustrated in the preceding Figures;

Figure 6 represents a control card with bar codes for a number of numeric and control characters;

Figure 7 is flow diagram illustrating an example of the operation  
5 of a data entry system as described with reference to Figures 1 to 6;

Figure 8 is a schematic block diagram of the functional elements of a second example of a hand held data entry device as shown in Figures 1A and 1B;

Figure 9 is a schematic block diagram of the functional elements  
10 of a further, self-contained, hand held data entry device which is intended for use without a base unit;

Figure 10 is a schematic block diagram of the functional elements of a further, self-contained, hand held data entry device for use without a base unit and intended, in particular, for use with a  
15 wireless telephone network such as a cellular network;

Figure 11 is a schematic block diagram illustrating components in an ASIC forming part of the apparatus of Figure 10; and

Figure 12 is a schematic block diagram illustrating the inter-relationship of functional elements of Figures 10 and 11.

20 Figures 1A and 1B are schematic views from above and below, respectively, of one embodiment of hand held data entry unit 10 which is substantially pen-shaped and which will hereinafter, for reasons of conciseness only, be referred to as the "pen 10". The pen 10 is intended to be held for essentially one handed operation between the  
25 thumb and forefinger of either the left or right hand in the manner of a conventional, if rather thicker than usual, pen.

The pen 10 has an elongate body 12 with, in the present example, external dimensions of approximately 120mm by 40mm, although the dimensions may be larger or smaller as desired subject to technical  
30 limitations. A reading head 14, for example a red or infra-red optical reading head (e.g., a laser diode) suitable for reading bar codes is located at one end of the pen. Other types of reading head may be provided. The reading head is preferably replaceable for interchanging types of reading head. A removable battery cover 16 covering a battery  
35 compartment is located at the other end of the pen. As an alternative to a compartment for removable batteries, a removable and/or fixed rechargeable battery pack could be provided instead. Also, the reading

head in the present embodiment is arranged to read with a reading angle of between 0° to 45° to the normal to the bar code to be read.

On the upper surface of the pen shown in Figure 1A a display screen 20, first and second microswitches 22 and 24, a first indicator light 26 and a second indicator light 28 are located. The display screen 20 preferably comprises a conventional two-dimensional array of pixels which can be selectively activated in order to provide the display of a wide range of displayable items. However, in a low cost version of the pen 10, the display may be configured only to display a predetermined range of characters and symbols, this reducing the complexity of the display and the controlling logic and thus reducing the cost as will be well understood by one skilled in the art.

Any suitable display technology can be used which enables the displayed information to be read over a wide enough angular range such that it can be read by the user when the pen is held at an angle suitable for reading a bar code. In this way it is not necessary to change the orientation of the pen in order to read the display. In view of the low power consumption and advantageous readability characteristics, a 2 line by 16 character supertwist LCD display screen is employed in the preferred embodiment giving a viewing area of approximately 60mm by 16mm with a character size of approximately 3mm by 5.5mm. The display is preferably located towards the end of the pen 10 opposite to the reading head 14 with its longitudinal axis substantially parallel to the longitudinal axis of the pen 10.

With the pen 10 held between thumb and forefinger with the user's hand below the pen as viewed in Figure 1A, and with the pen held at an angle of, say, 30° to the normal of a bar code to be read, (assuming that the normal to the bar code is generally in the direction of the line of sight of the user), the display screen can be read without difficulty.

The switches 22 and 24 are used to control basic operations of the data entry system and for control of the sequential display of stored information (scrolling of the display) as will be explained later. The indicator light 26 is used to report successful scanning of a bar code. The indicator light 28 is used when rechargeable batteries (70, Figure 3) are inserted in the battery compartment to indicate that

the batteries are charging.

On the lower surface of the pen 10 shown in Figure 1B, an optical transmitter 32 and an optical receiver 34 are provided in a shallow recess 33. Also, provided on the lower surface are a locating groove 36 and first and second electrical contacts 30 and 31. The optical transmitter 32 and the optical receiver 34 are used in combination with an optical receiver 62 and optical transmitter 64, respectively, on a base unit 40 to be described with reference to Figure 2, for the transfer of data between the pen 10 and the base unit 40. The locating groove 36 is used correctly to position the pen 10 with respect to a corresponding ridge in a cradle 56 on the base unit 40 when the pen 10 is placed in that cradle 56. The cradle 56 defines a rest position for the pen 10 on the base unit 40. The first and second contacts 30 and 31 are arranged to cooperate with corresponding contacts 60 and 61 in the cradle 56 on the base unit 40 for charging the rechargeable batteries.

Turning now to Figure 2, this illustrates a plan view of a base unit 40 for use with the pen 10 of Figures 1A and 1B.

The base unit includes a generally rectangular housing 42 with a raised portion 44 containing a power supply unit (102, Figure 4) which receives electrical power via a mains supply cable 45 and a mains switch 46. The mains switch 46 is located on the right hand side of the base unit housing 42. Cooling slots 47 for the power supply unit (102, Figure 4) are provided in the upper surface of the raised portion 44. Further slots 48 in the upper surface of the base unit housing 42 are located over a speaker (110, Figure 4) for relaying information to the user of the data entry system. The rear of the housing 42 is also provided with a socket 52 for a standard telephone plug for connecting the base unit 40 to a telephone line 50 and a standard serial connector 54 (e.g., an RS232 connector) for connecting the base unit to, for example, a personal computer (not shown). A manual switch 53 can be provided for switching between the telephone line and the serial connector. It will be appreciated that a parallel connector could be provided instead of, or in addition to, the serial connector 54. A separate telephone socket 55 can be provided for the connection of a standard telephone handset to the base unit.

Towards the front of the base unit housing 42, a recess is formed

which is configured as a cradle 56 for receiving the pen 10.

An optical receiver 62 and an optical transmitter 64 are located in the bottom of the recess for cooperating with the optical transmitter 32 and optical receiver 34, respectively, when the pen is located in the cradle 56. The optical receiver 62 and the optical transmitter 64 are surrounded by a wall 63 which also forms a shroud between the optical receiver 62 and the optical transmitter 64. The wall 63 cooperates with the recess 33 in the pen 10 to prevent external light reaching the optical link, and the shroud between the optical receiver 62 and the optical transmitter 64 prevents light from the two optical paths between the pen and the base unit and between the base unit and the pen from interfering with each other. It will be appreciated that alternative configurations are possible, for example the wall could be provided on the pen and the recess on the base unit, although this could mean that the pen was less comfortable to use.

First and second base contacts 60 and 61 are also located in the recess for cooperating with the contacts 30 and 31 on the pen 10 when it is inserted in the cradle 56, thus enabling rechargeable batteries (70, Figure 3) in the pen 10 to be recharged. A locating ridge 58 is formed in the recess for cooperating with the locating groove 36 in the bottom of the pen 10 to enable the pen to be positioned correctly in the cradle 56 such that the optical transmitter/receiver pairs 32/62 and 64/34 and the contact pairs 30/60 and 31/61 are aligned correctly.

The pen 10 can also be provided with a socket for directly charging the internal rechargeable batteries using an AC mains supply or a DC supply. In the first case the pen will include a transformer, in the second a transformer/rectifier could be incorporated in, for example, a mains plug.

On a further raised portion 66, one or two base unit indicator lights are provided. The first base unit indicator light 67 is for indicating the base unit is receiving mains power and is turned on. Optionally, the second base unit indicator light 68 can be used to indicate that rechargeable battery (70, Figure 3) in the pen is being charged.

Figure 3 is a schematic block diagram of the functional elements of the pen 10. A processor 74 is preferably formed by a conventional programmable microprocessor (e.g., an Intel 80C31 12 MHz CMOS

microprocessor with two internal clocks, an Intel 80486, etc.), although a special purpose or specially configured unit (e.g. an ASIC) could alternatively be used (compare Figure 10). A read only memory (ROM) 76 is connected via a bus 84 to the processor 74 for the storage of control programs and data. The ROM 76 can be implemented by any appropriate technology, for example by a flash PROM. A random access memory (RAM) 78 (for example a 128K low power static RAM, or higher capacity RAM, e.g. a 256K, 512K.. 5Mb, etc., RAM) is connected to the processor via the bus 84. The RAM 78 is used as working storage and for the storage of data captured using the reading head 14. A display interface 80, which connects the display 20 to the bus 84, responds to display instructions from the processor to drive the display in a conventional manner. An optical interface 86 is connected to the bus to convert data to be transmitted into signals for driving the optical transmitter 32; and converts signals from the optical receiver 34 into data to be passed to the bus 84.

In the present embodiment, other connections are made directly to the processor rather than via the bus. Thus, in the present embodiment, signals relating to data captured by the reader head 14 are passed directly to the processor 74 to be processed.

The manual switch 22 is also connected directly to the processor. In use this switch serves as a "scroll-down" key. The second manual switch 24, which in use serves as a "scroll-up" key, is, however, connected to the processor via a power control module (PCM) 72. This is because the switch 24 also serves as a "power-up" key for turning the pen on or powering it up after it has been powered down. The power control module 72 responds to operation of the key 24 in a powered down state to connect the battery 70 to the processor 74. The power control module 72 also controls the charging of the battery 70 when the contacts 30 and 31 are connected to the corresponding contacts 60 and 61 in the cradle 56 of the base unit 40. The indicator light 67 (e.g., an LED or NEON) is connected to the processor 74 and indicates when the base unit is connected to the mains. The optional indicator light 68 (e.g., an LED or NEON) is connected to the power control module 72 to indicate when the battery 70 is being charged.

The processor is programmed by means of control programs and data stored in the ROM 76 and, in use, in the RAM 78, to receive signals

from the reading head 14, to interpret those signals and to derive data therefrom which are displayed on the display 20 and stored in the RAM 78 for subsequent transmission via the optical interface as will be described in more detail below.

5 Figure 4 is a schematic block diagram of the functional elements of the base unit 40 of Figure 2. A power supply module 102 is connected to a mains supply via the switch 46 and the supply cable 45. The power supply unit 102 is also connected to the contacts 60 and 61 so that, when the pen 10 is located in the cradle 56, the battery 70  
10 can be recharged. The power supply unit 102 also supplies power to the other elements of the base unit via supply lines which are represented schematically (for reasons of drawing simplicity) by the arrows 104.

A modem 100 is connected via an optical link 106 to an optical receiver 62 and an optical transmitter 64. The optical interface 106  
15 converts signals from the optical receiver 62 to data to be passed to the modem 100 and converts data from the modem 100 to signals to be transmitted by the optical transmitter 64. A further interface (e.g. a standard V24/RS232 interface - not shown) for connection to a personal computer (not shown) could also be provided. Also a socket  
20 for a connection to a standard telephone handset (not shown) could be provided. The modem 100 can be a conventional modem generally comprising a master control unit 112, a data pump 114 and memory 118. The master control unit 112 is connected to receive data from the optical interface 106 (and/or from a V24/RS232 interface, if a personal  
25 computer is connected). Data from the data pump 114 are coupled via a line interface 116 to the telephone line 50. The data pump 116 is also connected via an audio interface 120 to a speaker 110 for monitoring the transmission of data via the telephone line 50.

Figure 5 is a schematic representation of a data entry network  
30 comprising a plurality of pens/base units 10/40 connected via respective telephone connections 50 (telephone lines, wireless telephone channels, etc) to a processing centre 108 where data transmitted from the individual pens/base units 10/40 are processed. In the preferred embodiment of the invention, the pens/base units 10/40  
35 are used for the placing of orders for merchandise and the processing centre 108 processes those orders and dispatches them to the users.

Figure 6 is a schematic representation of an example of a control



card for use with the pen 10. The card shows bar codes for the numerals 0 to 9 and for a set of commands. The command bar codes are used for controlling the operation of the pen 10. The control card can be thought of as a keyboard extension for the pen 10.

5 At this point it should be explained that the operation of reading a bar code is performed by the processor 74 in a conventional manner. Thus, where the head 14 comprises a red or infra-red light source and a light sensor, signals representing changing levels of reflected illuminations are supplied to the processor 74. Firmware  
10 stored in the ROM 76, or in other embodiments possibly hard-wired in the processor 74, is used then to decode the changing levels of reflected illumination to generate a numerical value. On successful reading of a bar code the good read light 26 is illuminated.

The processor tests the numerical values to determine whether the  
15 sensed code relates to data or a command. A look up table containing the numerical values for individual commands (not shown) is configured in the ROM 76 and/or RAM 78. By accessing this table, input commands can be identified. The controlling software is aware of which commands can be executed for the current processing state. On identifying a  
20 currently executable command, the processor 74 executes that command and causes the display of a human readable command description for user verification purposes. The processor causes an error message to be displayed on the display screen if a non-executable command (e.g., a command has been input at a wrong time) has been input.

25 If the code does not relate to a recognised command, it is treated as data. The data are then stored in RAM as the result of reading a bar code and are used to address a description of the item referenced by the bar code value from a further look-up table. If a description of the item corresponding to the bar code value is stored  
30 in the ROM 76 and/or the RAM 78 in a suitable data structure so that the bar code value can be used either directly or indirectly to address the appropriate description, then the item description can readily be displayed instead of or as well as the bar code value for user verification purposes. If the bar code is not read correctly, then an  
35 error message is displayed on the display screen.

The item description data can relate, for example, to items from a merchandising catalogue. In the this case the rewritable storage

capacity of the pen (e.g., the RAM 78) is chosen to be sufficient to store all the items from one or more merchandising catalogues. If the data is stored in volatile memory, this data is downloaded from the remote processing centre via the telecommunications link on restoring  
5 power to the memory in the pen. Preferably, if volatile memory is used, power is supplied to the memory even when the pen is "switched off". An integral rechargeable back-up battery can be provided in addition to the battery 70 to maintain power to a volatile memory when the battery 70 is being changed. If non-volatile memory is provided,  
10 then this data can be retained during a period when no power is supplied to the memory. However, through the use of rewritable memory and control logic enabling the memory to be updated using data downloaded from the remote processing centre, it is possible to keep the pen's memory up to date on a full list of merchandisable items,  
15 including product description, availability, price, etc. Then on reading a bar code relating to an item stored in memory the display on the pen can indicate a description of the item corresponding to the code read, its availability and price. If the code read is not recognised, for example, the pen can be programmed automatically to  
20 call up the remote processing centre to check on whether an update of the pen's storage is needed when the pen is replaced in the base unit.

Figure 7 is a flow diagram illustrating an example of a possible series of operations using an example of data entry system such as that described with reference to Figures 1 to 6. It will be appreciated  
25 that other sequences and modes of operation may be provided in other embodiments of the invention.

In a first step, S1, the pen 10 is removed from the base unit 40.

In step S2, "Up" key switch 24 is operated. The power control module senses operation of this key switch and powers up the processor  
30 74, which performs a series of diagnostic checks, calibrates itself and then displays an initial message (e.g., "Ready") on the display 20.

In step S3 the "Down" and "Up" scroll keys switches 22 and 24 are operated to scroll through a number of initial options pre-stored within the ROM 76 or the RAM 78 and presented on successive screens of data  
35 items on the display 20.

In this example of operation, in step S4, when an option "Left-handed operation" is encountered on the screen, the pen is scanned over

the "Enter" command bar code on the command sheet of Figure 6. Whereas for right-handed operation, where text is displayed in English, the text is displayed in sequence from the end of the display nearest to the reading head 14 towards the opposite end, for left-handed operation the text display is inverted with the text then reading from the end of the display furthest from the reading head to the end nearest thereto. It can be seen, therefore, that the text is displayed in an orientation appropriate for the user. If left-handed operation has already selected and it is desired to use the pen in a right-handed mode, then "Right-handed operation" can be selected by scrolling the display using the "Down" and "Up" key switches 22 and 24 and then scanning the "Enter" command bar code when the appropriate option is displayed.

Other options which could be provided in this manner could, for example, be the selected of one of a number of operating languages.

In step S5, the scroll key switches 22 and 24 are again operated until the option "Ready" is encountered once more. Then a series of merchandise selections can be entered by the user by scanning the bar codes for the desired merchandise selections and the command bar codes "Enter", "Clear", "Quantity", etc., as appropriate. As each bar code is scanned successfully, the good read indicator 26 lights and the data read by the bar code reader is displayed on the screen. Either the alphanumeric value of the bar code read is displayed or, if a description of the item corresponding to the bar code value is stored in the RAM or the ROM, then this can be displayed instead of or as well as the bar code value.

Step S5 can be repeated as often as desired until all the desired items have been entered, or until the RAM 78 has become full or nearly full, in which case a "Memory full" error message is displayed on the display screen 20.

If desired, the items entered and stored in the RAM 78 could be checked by selecting a "Check Entries" option with the scroll key switches 22 and 24. In this case the items entered can then be checked in sequence using the scroll key switches 22 and 24, and if necessary corrected by scanning the correct command bar code while the appropriate item is displayed.

In the example shown in Figure 6, however, after entering the desired items, a phone number is then entered in step S6 by scanning

the command bar code "Phone" followed by the number of the processing centre 108 to be called. As an alternative to entering separately the telephone number, this could be pre-stored in memory, or could alternatively be included in the "Phone" bar code.

5           After this, in step S7 the pen is placed in the cradle on the base unit and the "Down" key switch 22 is pressed to download the data from the pen. This causes the data for the telephone number to be downloaded to the modem 100 via the optical link 106. The downloading of the telephone number causes the base unit automatically to call the  
10 desired number and, once the normal modem handshaking is completed, to transfer the data stored in the RAM 78 in the pen 10. Preferably, in addition to the actual data stored, the processor 74 in the pen 10 automatically adds error correcting codes to enable the processing centre 108 to verify that successful transmission has occurred. The  
15 processing centre 108 then sends a message to confirm (or otherwise) whether successful transmission occurred after checking the error correcting codes. This message is then displayed on the display 20 of the pen 10.

It will be appreciated that the steps S1 to S7 illustrated above  
20 merely form one possible method of operation. In an alternative embodiment of the invention, the scrolling function is only used for stepping through items which have already been entered into the pen, whether in the form of selectable items downloaded from the remote processing centre and/or items selected by means of the reading head.  
25 All other command functions are input by reading appropriate command codes from a command sheet. For this embodiment therefore, a command sheet should include commands for left and right handed operation, or a command for changing handedness. Then, to change between left and right-handed operation, it is merely necessary to scan an appropriate  
30 command bar code.

In a final step (not shown in Figure 7), the pen is turned off by pressing the "Down" and "Up" scroll key switches simultaneously. It should be noted that the processor, which is provided with a date and time clock, is arranged to power-down the pen to conserve battery power  
35 if no bar codes are scanned and no key switches operated during a predetermined interval (e.g. 30 seconds). However, as mentioned above, power will be maintained to the RAM 76 if this is a non-volatile

memory.

The software stored in the pen also permits the loading of data from the processing centre or another remote computer. The programming is performed using a series of commands preceded by dot codes. The programming commands are thus known as "dot" commands and cover operations such as RAM PEEK, RAM POKE, ROM PEEK, DISPLAY, SENSE, GET INFO, GET FIRST ITEM, GET NEXT ITEM, GET PREVIOUS ITEM, AMEND ITEM, DELETE ITEM, CLEAR ORDER, CLEAR CATALOGUE, ADD CATALOGUE ITEM, and AMEND CATALOGUE ITEM. In this way, a significant amount of catalogue data and/or program software can be held in the processing centre and be sent to the pens only when required. Where programs are to be downloaded, rewritable program storage will be needed in the pen, for example by implementing the ROM 76 in flash PROM technology.

The processing centre can also send commands to a hand held unit to instruct the user to scan in a personal identification number (PIN), possibly with the scanning of a further verification number from, for example a verification device in the form of a verification card (e.g., a credit, payment or other validation card) or like carrier carrying a verification bar code and/or dot code for verification of a user identity. Alternatively, the verification device can be scanned prior to any connection to a remote processing centre. In this case a connection can then be made to the remote processing centre for verification of the user identity. Operation of the data entry system subsequent to an initial data capture operation can then be made dependent on the identification of authorised coded data and a PIN number.

Figure 8 illustrates another example of a pen in accordance with the invention. This example is substantially the same as the pen 10 described with reference to Figures 1 and 3, apart from the addition of a touch sensitive screen 90 for the display 20. A touch screen interface 88 couples the touch sensitive screen to the bus 84 so that data sensed by the touch sensitive screen can be communicated to the processor 74. Although Figure 8 shows a touch sensitive screen 90 (e.g., an overlay) separate from a conventional display screen, any applicable touch sensitive screen technology can be used, either through the use of an addition to an existing conventional display screen, or the use of a display screen with integral touch sensitivity. One or

more touch sensitive areas can be defined on the touch sensitive screen area, in combination with the data displayed on the display screen, for the entry of commands and/or the selection of displayed items. In particular, the processor 74 can be arranged to display a menu of user  
5 selectable items and to be responsive to a location at which the screen is touched for input of a user selection of a menu item. The touch sensitive screen can then thus be used as a dynamic and reconfigurable user interface. Touch screen entry can be used in place of or in addition to the entry of commands by scanning the bar codes on the  
10 command bar code card.

Figure 9 illustrates another example of a pen 10 in accordance with the invention. This example includes much in common with the pen 10 of Figure 3, except that here a modem 92, a socket 94 for a standard telephone plug and a speaker 95 for monitoring transmissions during  
15 operation of the modem are provided in place of the optical interface 86 and optical transmitter and receivers 32 and 34. In this example, therefore, data can be transmitted and received via a telephone line without the use of the base station, providing added portability. Preferably, a simplified base station is provided in the form of a  
20 charging unit for rechargeable batteries in the pen 10. It will be appreciated that the pen 10 could also be provided with the touch screen facility of the pen 10 of Figure 8.

Although in the above embodiments, the pens 10 are intended for manual scanning of bar codes, it will be appreciated that they could  
25 also be used for reading other optically readable codes, such as binary dot codes, by the provision of appropriate control software for programming the processor 74. Alternatively, in place of the sensor head 14 which is intended to be manually scanned, a self-scanning head could be provided.

30 The invention is also applicable to the reading of other coded data sources such as, for example, magnetic strips, graphical representations and/or alphanumeric characters, by the provision of an appropriate reading head and control logic.

Alternative removable heads could be attached to the tip of the  
35 pen by a screw, bayonet, friction or other appropriate attachment arrangement.

For example, the data entry pen could be provided with a reading

head which is responsive to movement of the pen for tracing out desired codes and or commands. In particular, by the provision of a rolling ball in a holder in the reading head, of rotation sensing means in the manner of a personal computer mouse for tracing movements of the ball and suitable interpretation logic in software or special purpose hardware, for defining a series of vectors as the pen is moved over a surface and for performing pattern recognition on the resulting vector patterns to identify control and/or alphanumeric characters traced out by the pen head, it is possible directly to input information into the pen by "writing" down those characters. By limiting the range of characters to be recognised (e.g., corresponding to the numerals and commands shown in Figure 6) it is possible to use conventional pattern recognition techniques with relatively limited processing power and storage requirements. It will be appreciated that increased processing power and storage can be provided in the pen described above for the embodiments of Figures 1, 3, 8 and 9 by the use of a more powerful processor and increased memory capacity.

Figure 10 illustrates a further embodiment of the invention. This further embodiment of the invention is similar to the embodiment of Figure 9, but this embodiment is intended for use with a wireless data transmission means, for example radio signals. In particular, the embodiment of Figure 10 is intended for use with a cellular telephone network, although it could be adapted for use with some other form of wireless telephone system, for example a satellite based telephone network.

The embodiment of Figure 10 is intended to be used independently of a base unit and to contain all the necessary functionality for independent operation. In one alternative the hand held unit is provided with a rechargeable battery pack 70, which can be removed from the hand held unit for recharging. In another alternative the hand held unit is provided with a fixed rechargeable battery pack 70. In the latter alternative, and optionally in the former alternative, a mains voltage charging socket and transformer/rectifier can be provided in the hand held unit or the battery pack for receiving a mains lead for charging purposes rather than the low voltage connectors 30/31. The low voltage DC charging connectors 30/31 can be configured in a socket for receiving an adapter lead, with a transformer/rectifier

being provided, possibly incorporated in a plug, for connection to a mains socket. It will be appreciated that an adapter for connection to, for example, a 12 volt DC supply from a car may also be provided. As a further alternative, contactless recharging (for example by  
5 magnetic induction) could be employed.

The embodiment of Figure 10 is implemented using a ASIC, although a conventional microprocessor and external hardware could be used. Likewise, it will be appreciated that the embodiments described with reference to the previous Figures could also be implemented using a  
10 ASIC or other equivalent technology instead of a microprocessor.

In the embodiment of Figure 10, the ASIC (Application Specific Integrated Circuit) performs the majority of the necessary processing functions of the device including:

- accepting data from the head 14;
- 15 - accepting data from the switches 22 and 24;
- driving the indicator 26;
- processing the data received from the head in the manner described with respect to the previous embodiments in order to extract the necessary information;
- 20 - controlling the flow of data in and out of the RAM 78;
- controlling the flow of data in and out of the ROM 76;
- interfacing with the power control module 72;
- implementing the modem function for use with an analogue telephony system and also providing the necessary processing and  
25 control for integration with a digital telephony system and/or a cellular telephone network;
- controlling the loudspeaker 95 permitting the progress of calls to be monitored;
- accepting input from a microphone 152 to enable the pen in  
30 combination with the loudspeaker 95 to operate as a hand set for the purposes of audio telephony;
- controlling the flow of data to an optional printer socket (not shown) allowing a user to print out information relative to the code being scanned in a predefined format;
- 35 - controlling the output of data via an optical link 153 to a peripheral device (e.g., a printer) using for example, infra red light;



- controlling an interface to the display 20, the display interface functions being performed in the ASIC.

The optical link 153 could be implemented using the optical link technology described above for interfacing a hand held unit with a base station. Indeed, the printer or other peripheral device could be  
5 implement as, or connected to a base station for the hand held unit.

Figure 11 illustrates in more detail the configuration of the ASIC 150.

The ASIC comprises the system controller 165 that controls the  
10 operation of the pen and of its associated components. In this embodiment system controller 165 consists of a microcontroller core incorporated into the ASIC. In other embodiments it could consist of some other control means using, for example, one or more finite state machines.

15 If the system controller 165 is a microcontroller core, then the data that controls its operation is stored in an internal ROM 163 together with the external ROM 76. Alternatively, there could be no internal ROM 163 and the system controller 165 will then obtain all the data from the external ROM 76. Alternatively, again, the internal ROM  
20 163 could be used exclusively without an external ROM 78. However, this would reduce the flexibility of the device. The use of the internal ROM 163 is advantageous where a pre-defined amount of the operations to be performed are fixed for all pen types, whilst the remainder of the operation is dependent on a particular model, to take  
25 account for example of language variations, number of switches used to enter data, etc. The RAM 161 in the ASIC can be used by the system controller 165 as a scratch pad RAM to speed up operations and in order to reserve the maximum amount of RAM 78 for the storage of the main data. This "main data" includes data identifying information relating  
30 to selectable items of, for example, a merchandising catalogue, which can be down loaded by telephonic transmissions from a remote station.

The microcontroller receives requests via the bus 84 which is connected to the external bus 84 illustrated in Figure 10. However, in an alternative embodiment where the system controller 165 consist of a  
35 number of finite state machines, then control would be by means of the fixed interconnection of the logic in the fixed state machines.

RAM 161 could be used as a short term data store leaving the RAM

78 to store the main data, the data in RAM 78 being retained by the battery 70. An additional battery (not shown) could be provided for data retention to prevent the loss of data from the RAM 78 or the RAM 161 in the event of failure of the battery 70.

5           The switch interface 155 responds to the operation of the switch 22 and ensures that the system controller 165 receives signals which are devoid of bounce (resulting for example from multiple operations of the switch due to the spring operation within the switch).

10           The head interface 156 carries out the necessary signal conditioning as required on receiving signals from the head 14. The signal conditioning will depend on the exact configuration of the head and preferably comprises simple buffering of the data read. Alternatively, it could be implemented to provide at least some of the bar code conversion operations as will be apparent to one skilled in  
15 the art.

          Selector 159 is controlled by the system controller 165 and functions in such a manner to allow the microphone 152 and the speaker 95 to provide standard audio telephony transmission or to allow the system controller to transfer the data over the telephony network  
20 using, in the present embodiment, conventional cellular telephone technology.

          Thus the selector 159 enables the data entry device to be used as a conventional cellular telephone for the transmission of audio signals. In conventional telephony mode, the selector 159 takes  
25 signals from the microphone 152 that have been processed by the signal processor 158 and directs the output to the line interface 116. The processing performed by the processor 158 can comprise, as will be apparent to one skilled in the art, conventional operations of buffering the microphone to filter out any frequencies not required and  
30 to amplify the signal to a suitable level. Received audio data is directed to the audio interface 157 which performs necessary signal conditioning before passing the signal to the speaker 95.

          In the data transfer mode, the selector takes the output from the data formatter 160, which has prepared the data to be transmitted over  
35 the cellular telephone network, and directs this to the line interface 152. The speaker 95 is then used to output any tones or audio messages indicating errors, correct operation, etc., again via the audio

interface 157.

Switching between modes can be accomplished using the keys and/or the scanning sensor of the hand held unit in the manner described above for the entry of data and/or commands.

5       The output formatter 164 prepares the data to be transmitted to a remote printer via an optical link 153 (not shown). This transmission could be in any one of a number of forms, for example, infra red light using technology as described above for interfacing the pen with a base unit. Alternatively, other remote link technology, for  
10       example a radio link, could be provided.

Figure 12 illustrates aspects from Figures 10 and 11 to illustrate in more detail the incorporation of an example of a cellular telephone system within the data entry unit. The telecommunications interface 116 comprises a line interface/duplexer which is connected to  
15       an aerial 178. The line interface/duplexer 116 is connected to a transmitter 170 and to a receiver/synthesizer 172 implemented in the selector 159. Also implemented in the selector 159 is selector logic 174 for connecting the transmitter 170 and the receiver/synthesizer 172 to the signal processor 158, the audio interface 157, the data  
20       formatter 160 and the control logic 165 within the ASIC 150.

Although specific embodiments of the invention have been described hereinabove, it will be appreciated that many modifications and/or additions are possible within the scope of the present invention.

25       Thus, for example, although in the presently preferred embodiments described above the hand held unit is configured with the shape of a pen, it will be appreciated that the hand held unit could be configured in other shapes as desired in other applications, for example in the shape of a pistol.

30       Although in the examples of the pen and base unit described with reference to Figure 1 to 4 and 8 an optical link between the pen and the base unit is provided, in an alternative embodiment other wireless data transmission means, for example radio signals, could be used, in the manner of a portable telephone of the type with a portable handset  
35       and a base unit.

The data from the memory of the pen (e.g., the complete list of items which could be ordered from a catalogue) could conveniently be

output in alphanumeric form via a modem to a facsimile (fax) machine for printing the content of the memory.

In the preferred embodiments described above, catalogue data is down-loaded into the pen from a remote processing system by telephone. 5 over the telecommunications interface. However, as an alternative to down-loading, for example a complete catalogue, via the telephone line, other data entry means could be provided for the bulk of the data, the telephone line then only being used for updating the stored data. For example the pen and/or the base unit as appropriate could be provided 10 with a socket or connector or reader for a memory device (such as a plug-in ROM, a smart card, etc.).

Although no speaker is illustrated in the examples of the pen described with reference to Figures 3 and 8, a speaker or other sound generator could be provided as in the Figures 9 and 10 embodiments for 15 giving audio feedback to report on the correct reading, or otherwise, of a code. Thus, for example, when a code is correctly read, one beep can be sounded, and when a code is incorrectly read, two beeps could be sounded. Alternatively, appropriate synthetic or recorded voice messages could be output.

20 Although in the examples described above the plane of the display is generally parallel to the axis of the pen, the plane of the display 20 could be arranged to slope progressively towards the axis of the pen away from the head end of the pen to reduce the angle between the normal to the plane of the display and the line of sight of the user.

25 Also, although in the present examples two mechanical key switches are provided, in other embodiments one key switch only could be provided. Operating that key switch a predetermined number of times within a short period could be used to emulate the provision of two key switches for scrolling and other functions. More key switches could 30 also be provided in other embodiments. For example, a numerical keypad could be provided. However, in preferred embodiments of the invention, the number of keys should be kept as low as possible for any particular application. As in the embodiments described above, two key switches are preferred. The control sheet or data carrier effectively forms a 35 keyboard extension for the pen.

Although in the example of a card or other carrier shown in Figure 6 a set of bar codes for only numeric and command codes are

indicated, if desired a set of bar codes for the complete alphabet could be provided. Alternative arrangements of the codes would also be possible, for example a complete set of codes and corresponding characters could be arranged in the format of a standard typewriter keyboard layout. The codes could also be incorporated in the letters and numerals, for example extending as a strip across the letters and numerals. For example, a bar code could replace the cross bar in a capital "A", and similar modifications for the other letters of the alphabet.

Also, as mentioned above, in appropriate embodiments of the invention, codes other than bar codes or dot codes could be used. For example a symbol blob code could be used, this requiring about 1Kbyte of storage for decoding purposes. Indeed, in other embodiments of the invention full character recognition (OCR) could be employed where the reading sensor is in the form of a camera or other scanning sensor incorporated in the reading head. With a camera and appropriate recognition logic, the pen could be used, for example, for fingerprint recognition, either as an aim in itself, or for user validation purposes.

In a merchandising system, where bar codes or other codes are associated with merchandisable items, this could be achieved simply by means of a printed catalogue, or some other form of list, or as a result of codes applied to examples of the products in question, or as a result of codes displayed, for example, on a TV screen with images relating to those products. The only requirement is that the display of the codes are readable by the data entry system of the present invention.

Features from the respective embodiments of the invention described above could also be combined as desired to provide a configuration appropriate for a particular application.

Thus, for example, the audio telephony functions described with reference to the embodiment of Figures 10 to 12 could be incorporated in the hand held or base unit, as appropriate, of the other embodiments of the invention.

Although in the specific embodiments described above the telecommunications interface for the telephonic transmission of information is only provided in a hand held unit where no base unit

with a telecommunications interface is provided, it will be appreciated that a hand held unit with a telecommunications interface could be combined with a base unit also having a telecommunications interface, either of the same or a different type.

CLAIMS

1. A data entry system comprising a hand held data entry unit, said hand held unit comprising a reading sensor for sensing commands and/or data and for producing input signals in response to said sensed commands and/or data, rewritable storage for information relating to selectable items, a controller connected to receive and process said input signals from said sensor for responding to said commands to control said hand held unit and/or to said data to select a said item and a display screen for displaying a user readable representation of said commands and/or stored information for said selected item, and a telecommunications interface for telephonic transmission of information relating to a selected item or items from said storage to a remote processing centre and for telephonic transmission of information relating to selectable items from said remote processing centre to said storage.
2. A data entry system according claims 1, wherein said telecommunications interface is integral to said hand held unit.
3. A data entry system according to claim 2, wherein said hand held unit includes a rechargeable power source, means being provided for recharging said power source.
4. A data entry system according to claim 3, comprising a base unit separate from said hand held unit, wherein said base unit includes a charger unit and said base unit and said hand held unit are provided with respective interconnectable electrical connectors for recharging said rechargeable power source.
5. A data entry system according to any one of the preceding claims comprising a base unit separate from said hand held unit, wherein said base unit and said hand held unit are provided with a wireless data link which is operable for bidirectional data transfer between said hand held unit and said base unit, and wherein said base unit includes a said telecommunications interface for telephonic transmission of information relating to a selected item or items from said storage to

a remote processing centre and for telephonic transmission of information relating to selectable items from said remote processing centre to said storage.

5 6. A data entry system according to claim 5, wherein said wireless data link comprises, in said base unit and said hand held unit, optical transmitters and/or receivers which cooperate when said hand held unit is in said rest position to provide a two way optical data link for transferring data from said hand held unit to said base unit and/or  
10 from said base unit to said hand held unit.

7. A data entry system according to any one of the preceding claims, wherein said telecommunications interface is an interface for connection to a wireless telephone network.  
15

8. A data entry system according to claim 7, wherein said telecommunications interface is a cellular telephone network interface.

9. A data entry system according to claim 7, wherein said  
20 telecommunications interface is a satellite telephone network interface.

10. A data entry system according to any one of the preceding claims, wherein said telecommunications interface includes a modem.  
25

11. A data entry system according to any one of the preceding claims, wherein said hand held unit comprises one or two manually operable switches for scrolling said display in a first and/or second direction for selectively displaying information for respective selectable or  
30 selected items from said storage.

12. A data entry system according to claim 11, wherein operation of said first and/or second switches in predetermined operational states of said hand held unit causes predetermined functions other than  
35 scrolling functions to be performed.

13. A data entry system according to any one of the preceding claims,



wherein said display comprises a touch sensitive screen, said controller being arranged to display a menu of user selectable items and to be responsive to a location at which said screen is touched for input of a user selection of a said menu item.

5

14. A data entry system according to any one of the preceding claims comprising a reading sensor for reading coded data, wherein said controller is arranged to access the stored information for selectable items to determine natural language characters or images corresponding to the coded data for display.

10

15. A data entry system according to claim 14, wherein said coded data comprises bar codes and/or binary dot codes and said sensor is a bar code and/or dot code reader.

15

16. A data entry system according to any one of claims 1 to 13, wherein said reading sensor is a camera.

17. A data entry system according to any one of the preceding claims, wherein said controller is user programmable to cause said captured data to be displayed on said display either in a first orientation suitable for reading displayed data when said hand held unit is held in a user's right hand, or in a second orientation suitable for reading displayed data when said hand held unit is held in a user's left hand, said controller being responsive to user programming operations including scanning of an appropriate command code using said reading sensor.

20

25

18. A data entry system according to any one of the preceding claims wherein said display has a substantially rectangular display screen with a longitudinal axis arranged substantially parallel to a longitudinal axis of said hand held unit.

30

19. A data entry system according to any of the preceding claims, comprising means enabling audio telephone conversations with a remote station.

35

20. A data entry system according to claim 19 wherein said hand held unit includes a speaker and/or microphone and switching means permitting said hand held unit to be used as a telephone handset.

5 21. A data entry system according to any one of the preceding claims wherein said hand held unit is configured as an elongate unit such that it may be held by a user in the manner of a pen or quill with said reading sensor being located in a reading head at or adjacent to one end of said hand held unit.

10

22. A data entry system according to any one of the preceding claims wherein said reading sensor is located in a reading head which is releasably attached to said hand held unit.

15 23. A data entry system according to any one of the preceding claims additionally comprising, separate from said hand held unit:

- means for displaying a plurality of selectable items with associated data sources for user selection of an item by operation of said hand held unit; and

20 - a remote processing centre for processing user selections transmitted from said hand held unit.

24. A data entry system according to any one of the preceding claims, wherein said hand held unit is programmable remotely from said  
25 processing centre with information relating to selectable items.

25. A merchandising system comprising a data entry system according to claim 23 or claim 24, wherein:

- said selectable items are merchandisable items; and

30 - said remote processing centre initiates processing of user orders of said selectable merchandisable items.

26. A data entry system according to any one of claims 1 to 24 or a merchandising system according to claim 25 comprising a verification  
35 device in the form of a verification card or like carrier carrying a verification bar code and/or dot code for verification of a user identity.

27. A data entry system according to any one of claims 1 to 24 or a merchandising system according to claim 25 or claim 26 comprising a carrier for a plurality of data and/or command codes for association with means for displaying a plurality of selectable items, wherein said  
5 carrier carries a plurality of codes, each for a respective one of a plurality of natural language and/or numeric characters and a plurality of commands for controlling operation of said data entry or merchandising system, each code being associated with a visual  
10 representation of the corresponding natural language or numeric character or command and/or of a graphical representation thereof.

28. A data entry system or a merchandising system according to claim 27 wherein said codes are bar and/or dot codes.

15 29. A data entry system substantially as hereinbefore described with reference to the accompanying drawings.

30. A merchandising system substantially as hereinbefore described with reference to the accompanying drawings.

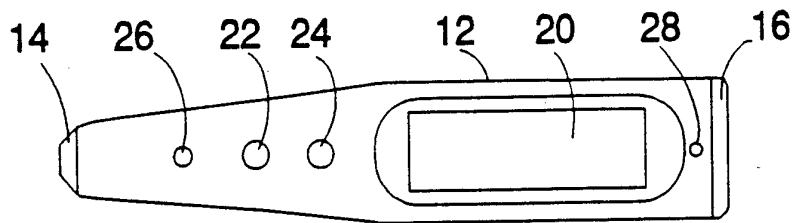

10

**FIG. 1A**

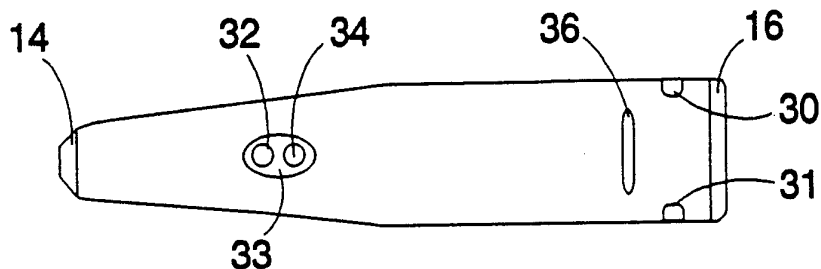

10

**FIG. 1B**

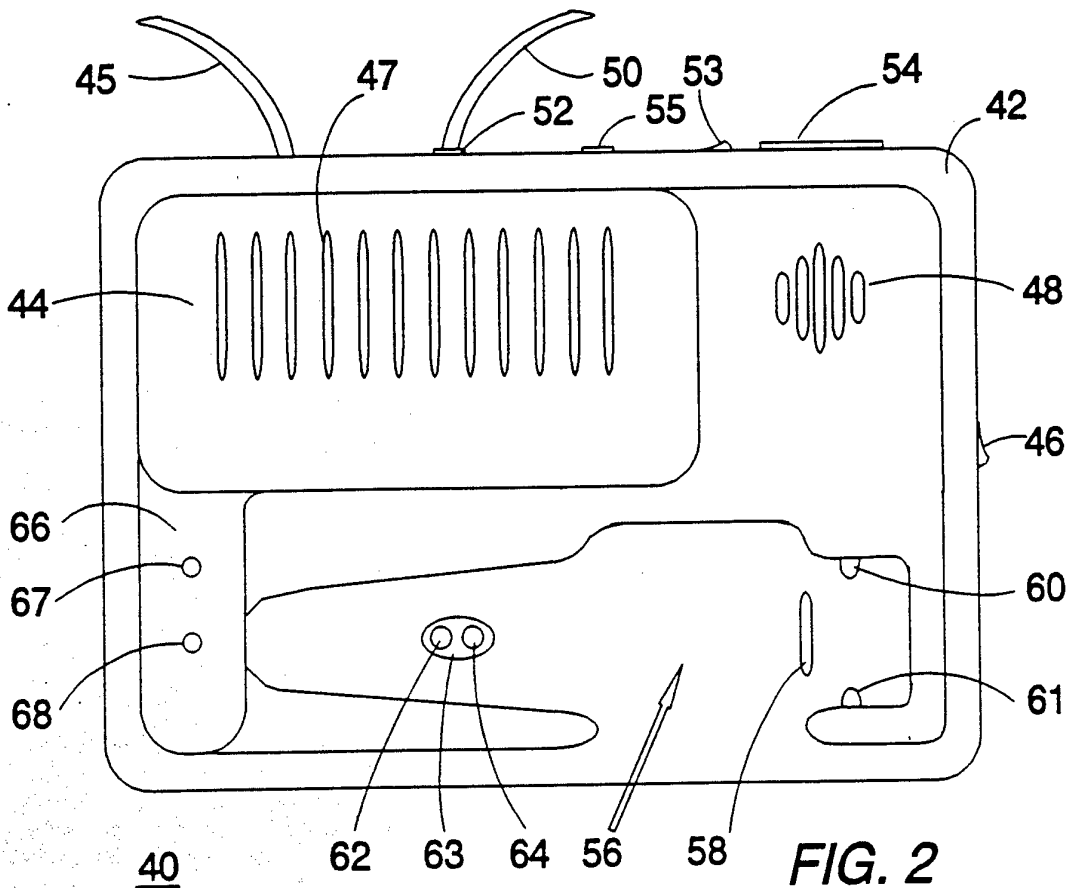

40

**FIG. 2**

2/11

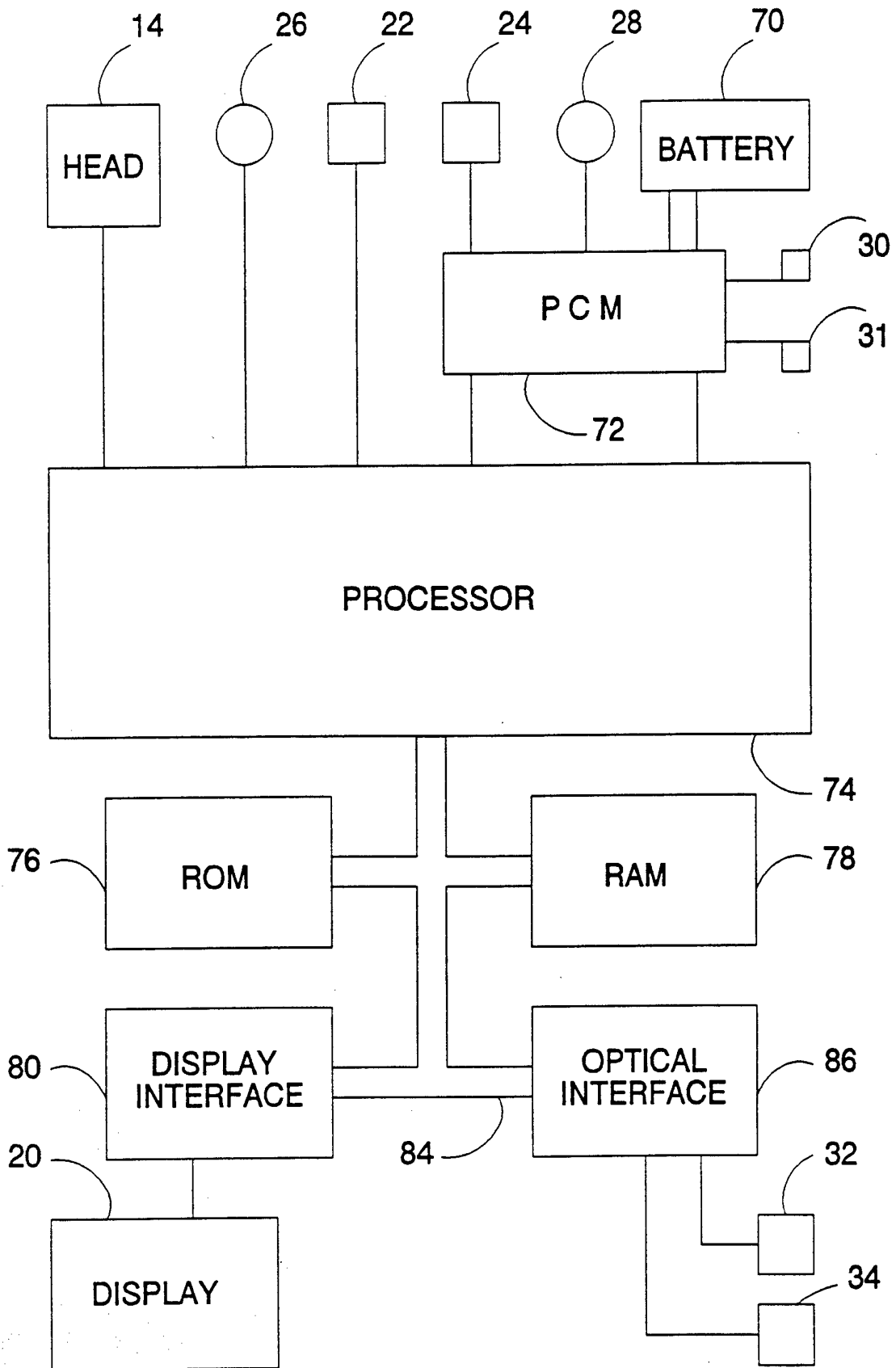

FIG. 3

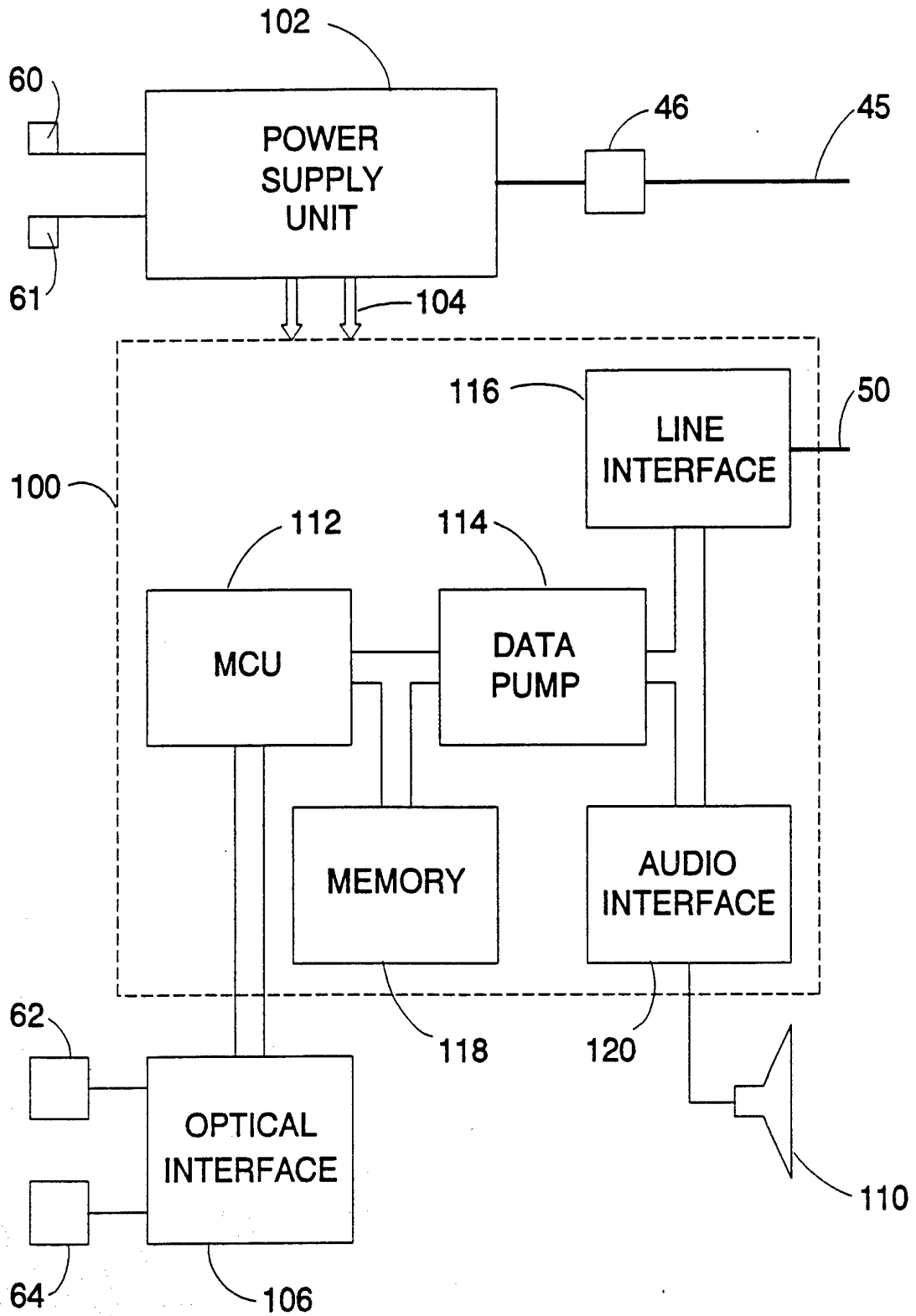

FIG. 4

4/11

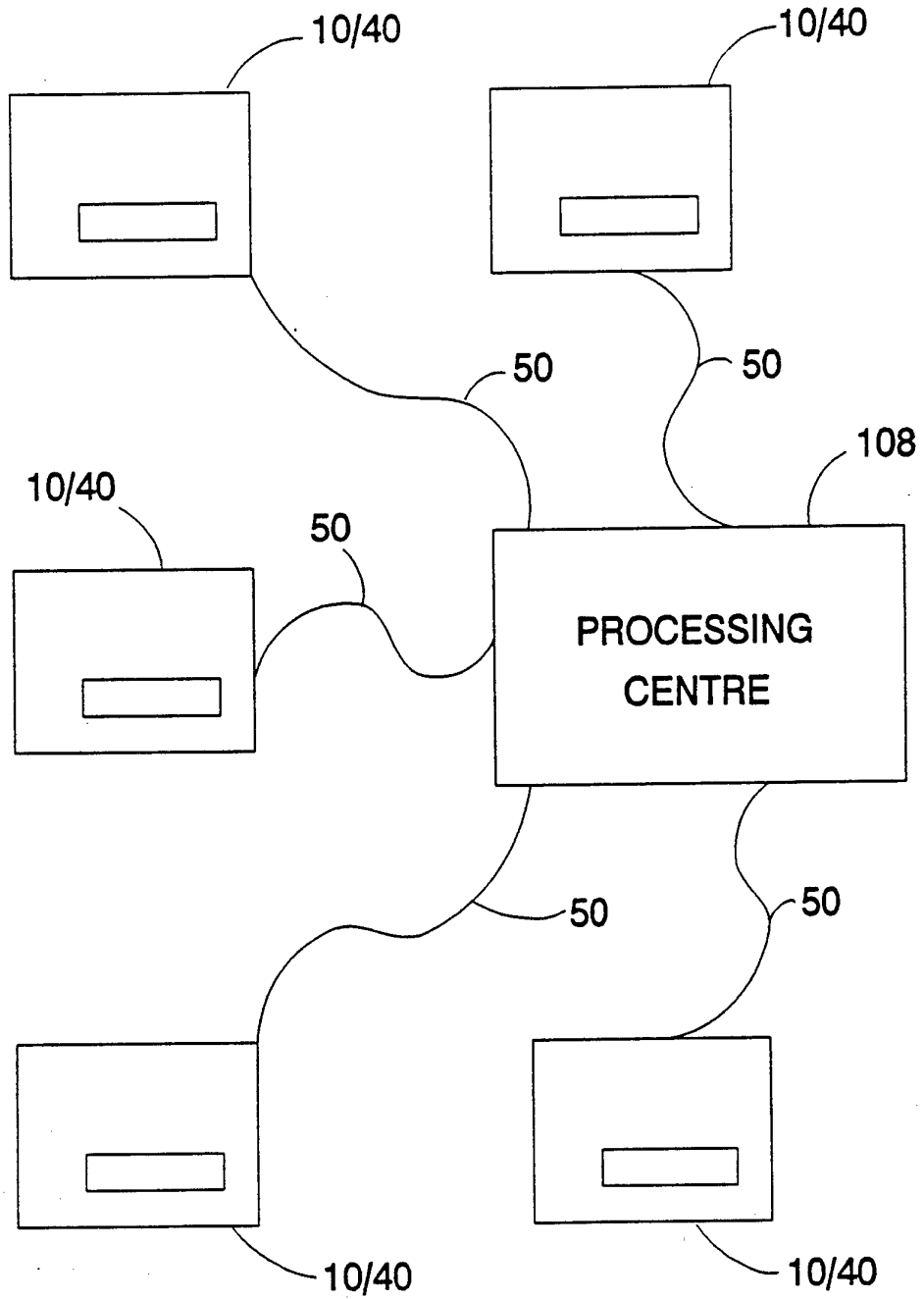
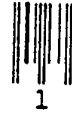

FIG. 5

5/11



1



2



3



4



5



6



7



8



9



0



Correct



Clear



Enter



Quantity



Tone/Pulse



Phone



Delete



Pin

FIG. 6



6/11

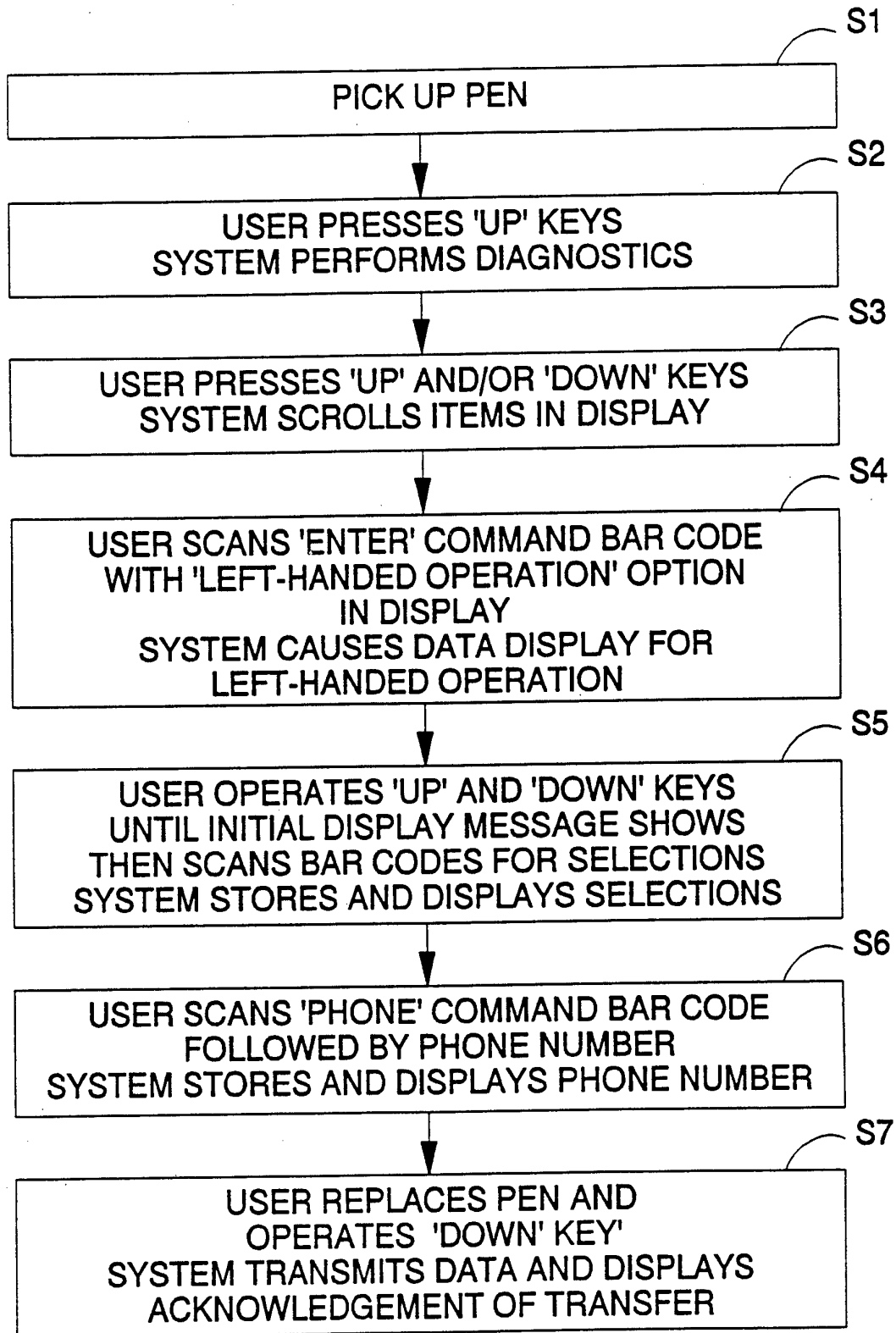

FIG. 7

7/11

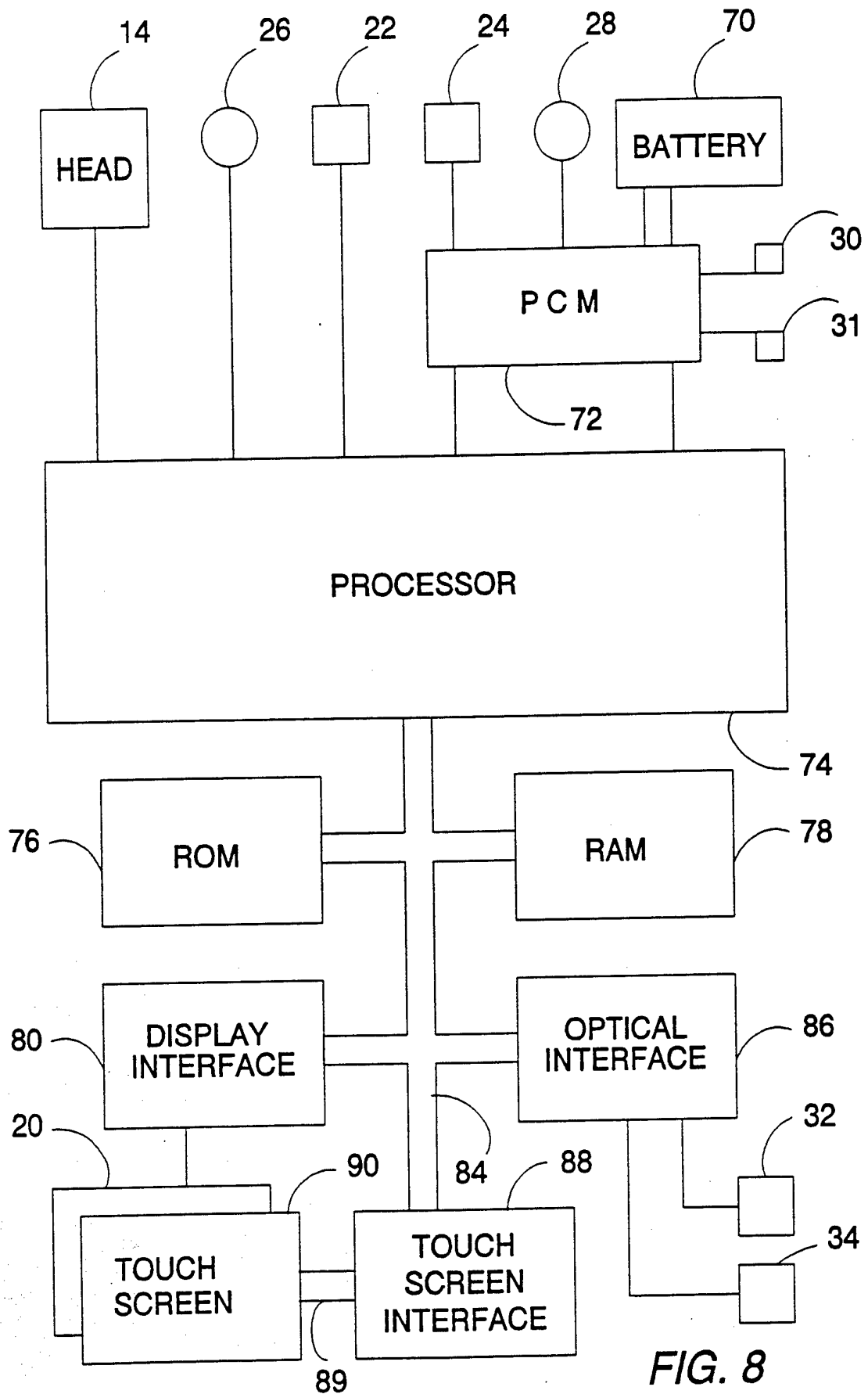

FIG. 8

8/11

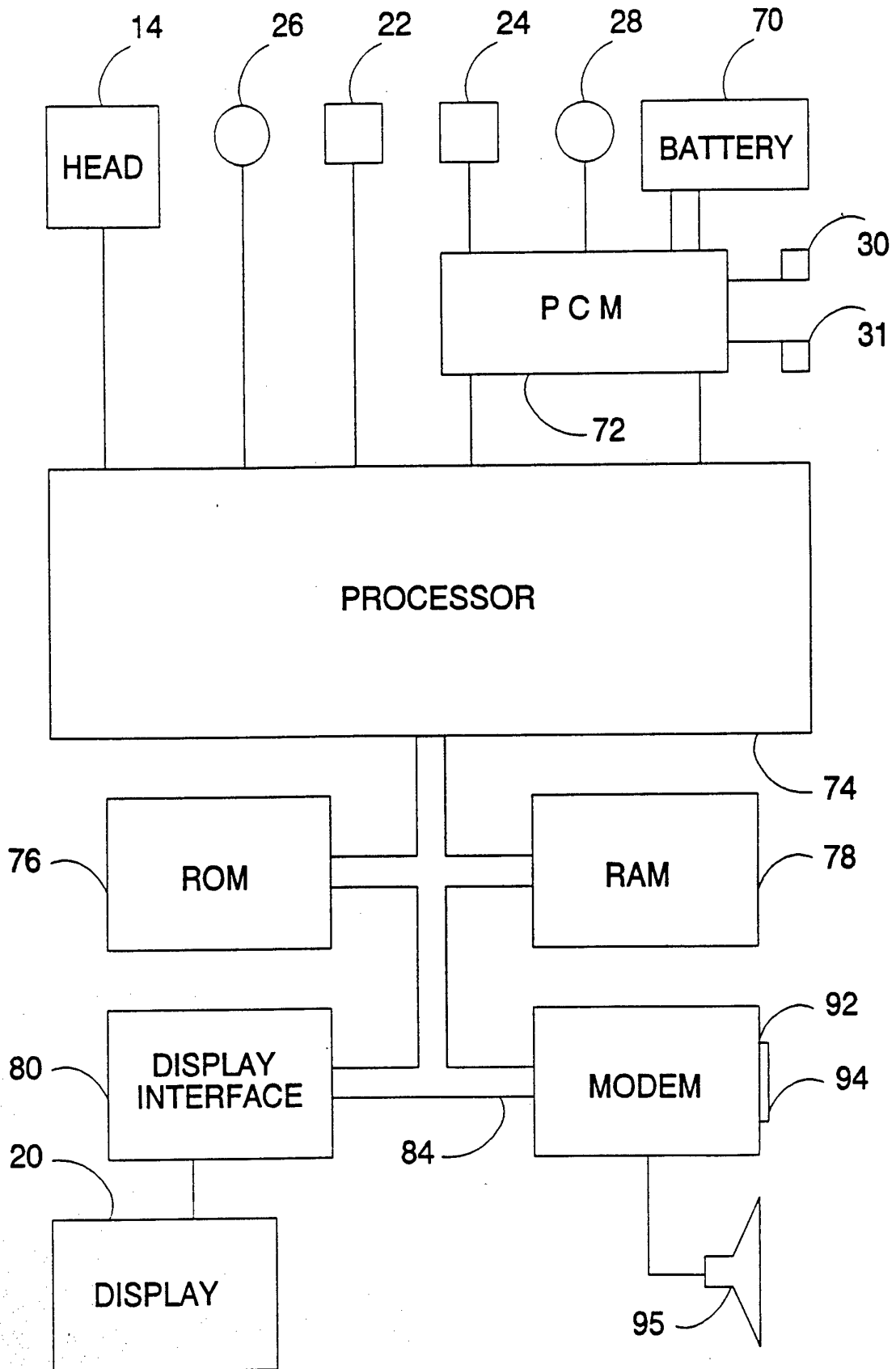

FIG. 9

9/11

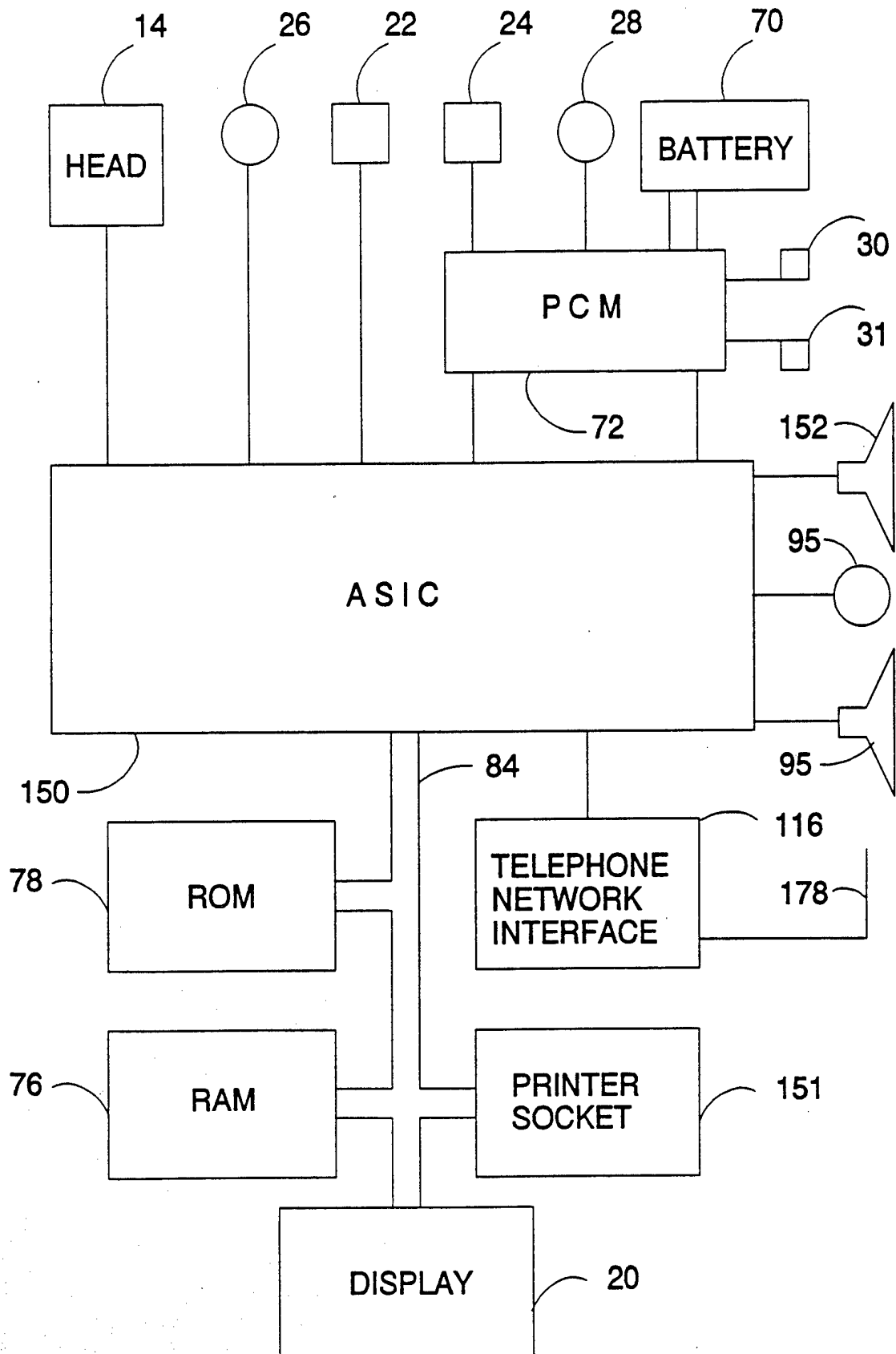

FIG. 10

10/11

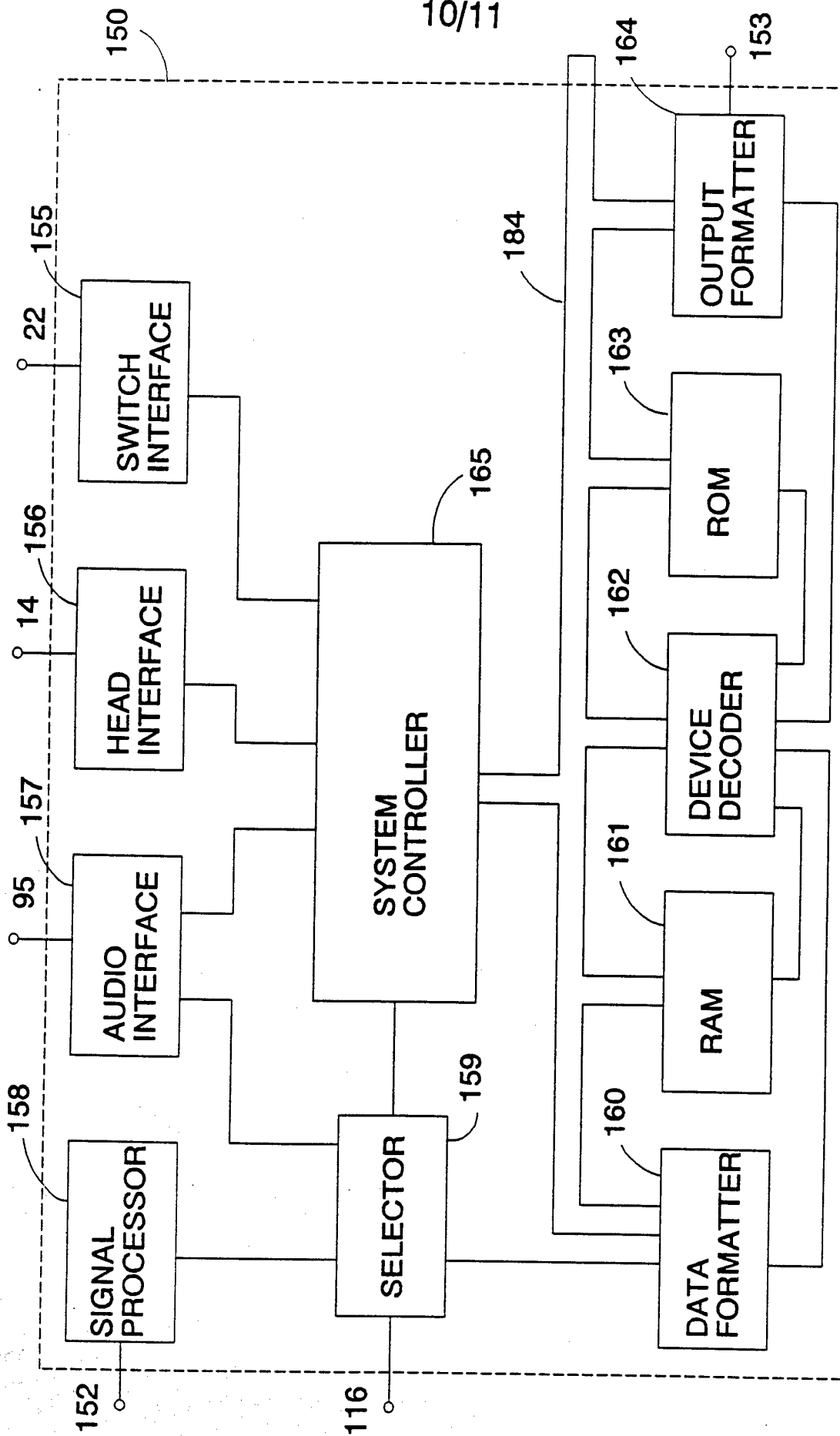

FIG. 11

11/11

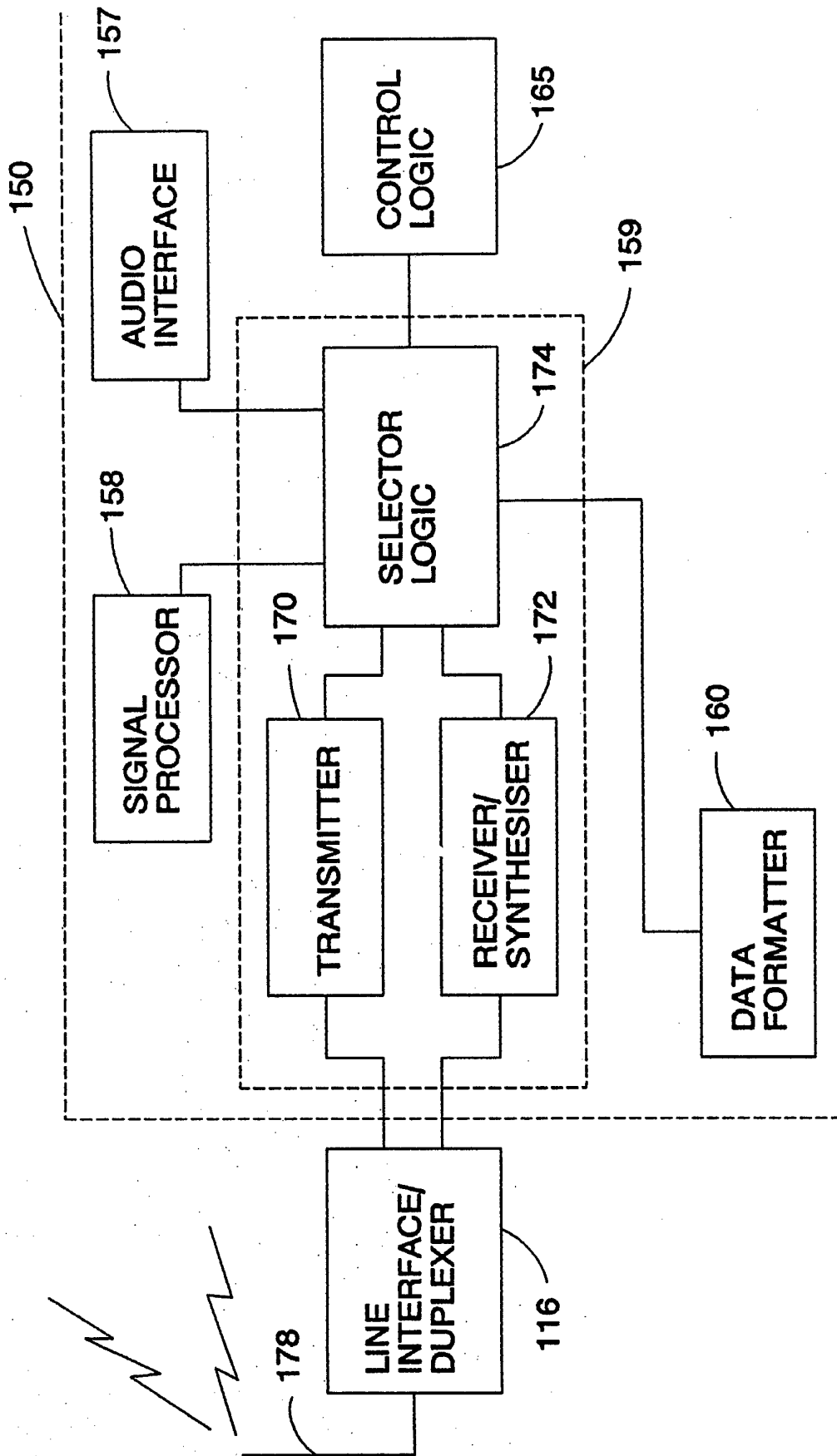

Fig 12

INTERNATIONAL SEARCH REPORT

Internat: Application No  
PCT/GB 94/02101

A. CLASSIFICATION OF SUBJECT MATTER  
IPC 6 G06K7/10 G06K17/00

According to International Patent Classification (IPC) or to both national classification and IPC

B. FIELDS SEARCHED

Minimum documentation searched (classification system followed by classification symbols)  
IPC 6 G06K

Documentation searched other than minimum documentation to the extent that such documents are included in the fields searched

Electronic data base consulted during the international search (name of data base and, where practical, search terms used)

C. DOCUMENTS CONSIDERED TO BE RELEVANT

Category *	Citation of document, with indication, where appropriate, of the relevant passages	Relevant to claim No.
X	WO,A,91 00574 (PARIENTI, RAOUL) 10 January 1991	1,2,14,15,19
Y	see claims 1-7; figures 1,2	3,4,11-13,17,18,21-28
Y	--- WO,A,89 04016 (ZENGRANGE LIMITED) 5 May 1989 see page 11, paragraph 3 - page 12, paragraph 1; figures 2,3	3,4
Y	--- GB,A,2 202 664 (GARY DOUGLAS ROBB) 28 September 1988 cited in the application see the whole document ---	11,12,26
	-/--	

Further documents are listed in the continuation of box C.  Patent family members are listed in annex.

\* Special categories of cited documents :

"A" document defining the general state of the art which is not considered to be of particular relevance

"E" earlier document but published on or after the international filing date

"L" document which may throw doubts on priority claim(s) or which is cited to establish the publication date of another citation or other special reason (as specified)

"O" document referring to an oral disclosure, use, exhibition or other means

"P" document published prior to the international filing date but later than the priority date claimed

"T" later document published after the international filing date or priority date and not in conflict with the application but cited to understand the principle or theory underlying the invention

"X" document of particular relevance; the claimed invention cannot be considered novel or cannot be considered to involve an inventive step when the document is taken alone

"Y" document of particular relevance; the claimed invention cannot be considered to involve an inventive step when the document is combined with one or more other such documents, such combination being obvious to a person skilled in the art.

"&" document member of the same patent family

Date of the actual completion of the international search <b>9 January 1995</b>	Date of mailing of the international search report <b>20.01.95</b>
--	---

Name and mailing address of the ISA European Patent Office, P.B. 5818 Patentlaan 2 NL - 2280 HV Rijswijk Tel. (+31-70) 340-2040, Tx. 31 651 epo nl, Fax: (+31-70) 340-3016	Authorized officer  <b>Chiarizia, S</b>
--	---

## INTERNATIONAL SEARCH REPORT

Internat	Application No
	PCT/GB 94/02101

## C.(Continuation) DOCUMENTS CONSIDERED TO BE RELEVANT

Category *	Citation of document, with indication, where appropriate, of the relevant passages	Relevant to claim No.
Y A	US,A,4 916 441 (GOMBRICH) 10 April 1990 see column 5, line 34 - line 50; figure 5 ---	13 1
Y	US,A,5 023 438 (WAKATSUKI ET AL.) 11 June 1991 see abstract; figure 7 ---	17,18
Y	EP,A,0 094 571 (MSI DATA CORPORATION) 23 November 1983 cited in the application see page 12, line 8 - line 11; figures 1-3 ---	21-25, 27,28
X	WO,A,87 07106 (CLINICOM INCORPORATED) 19 November 1987 see page 11, line 24 - page 13, line 19; figures 4,7 -----	1,3-5, 10,16



## INTERNATIONAL SEARCH REPORT

Information on patent family members

Internationa Application No

PCT/GB 94/02101

Patent document cited in search report	Publication date	Patent family member(s)	Publication date
WO-A-9100574	10-01-91	FR-A- 2648932	28-12-90
		AT-T- 113130	15-11-94
		AU-A- 5933090	17-01-91
		CA-A- 2035462	24-12-90
		DE-D- 69013470	24-11-94
		EP-A- 0431138	12-06-91
		US-A- 5189287	23-02-93
-----	-----	-----	-----
WO-A-8904016	05-05-89	AU-A- 2800089	23-05-89
-----	-----	-----	-----
GB-A-2202664	28-09-88	NONE	
-----	-----	-----	-----
US-A-4916441	10-04-90	NONE	
-----	-----	-----	-----
US-A-5023438	11-06-91	JP-A- 2144680	04-06-90
		JP-A- 2144681	04-06-90
-----	-----	-----	-----
EP-A-0094571	23-11-83	US-A- 4471218	11-09-84
		DE-A- 3376284	19-05-88
-----	-----	-----	-----
WO-A-8707106	19-11-87	AU-A- 6547686	01-12-87
		CA-A- 1268253	24-04-90
		US-A- 4850009	18-07-89
-----	-----	-----	-----