

J. MILBURN.
PUMP.
APPLICATION FILED DEC. 3, 1910.

999,832.

Patented Aug. 8, 1911.

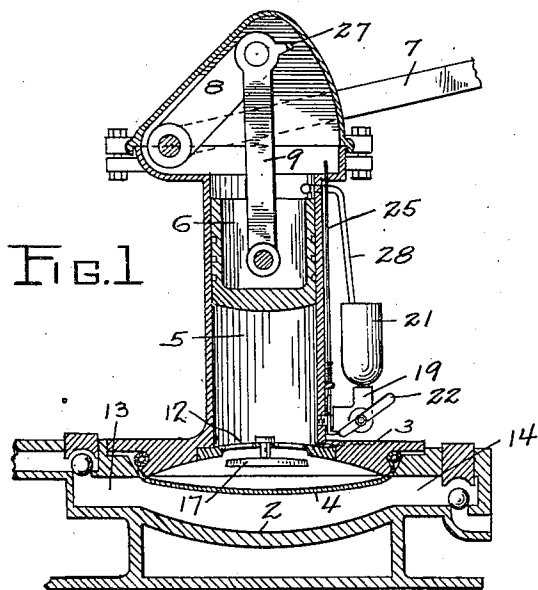

FIG. 1

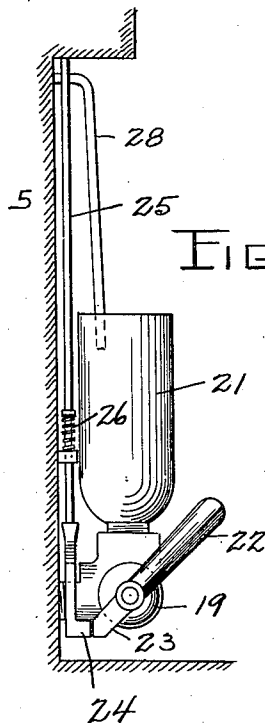

FIG. 2

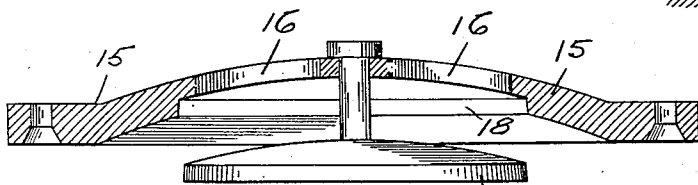

FIG. 3

WITNESSES:

H. G. Post.

T. S. Pisswell

INVENTOR
JOSEPH MILBURN

By Miller & White

ATTORNEYS

UNITED STATES PATENT OFFICE.

JOSEPH MILBURN, OF SAN FRANCISCO, CALIFORNIA.

PUMP.

999,832.

Specification of Letters Patent. Patented Aug. 8, 1911.

Application filed December 3, 1910. Serial No. 595,377.

To all whom it may concern:

Be it known that I, JOSEPH MILBURN, a citizen of the Dominion of New Zealand, and a resident of the city and county of San Francisco and State of California, have invented certain new and useful Improvements in Pumps, of which the following is a specification.

The invention relates to that class of pumps, generally known as diaphragm pumps, in which a flexible diaphragm is acted on by liquid pressure on one side to cause the volume in the casing on the other side of the diaphragm to be varied and thereby draw in and discharge the liquid to be pumped. This class of pumps is used principally to pump chemicals which would have a corroding action on the cylinder, or water containing certain materials in suspension which would lodge in the cylinder and destroy its efficiency. In a pump of this class a pump cylinder, having a piston reciprocable within it, is in communication with a chamber which is divided into two compartments by a flexible diaphragm. Liquid is employed in the cylinder below the piston and when the piston is reciprocated, the flexing of the diaphragm causes the fluid to be pumped to be alternately drawn into and expelled from the chamber on the opposite side of the diaphragm.

Heretofore, as far as I am aware, no means have been employed to prevent an excessive pressure on the cylinder side of the diaphragm and in many instances where the quantity of liquid in the piston has been excessive the diaphragm has been ruptured.

The object of this invention is to provide means for preventing any excess pressure on the diaphragm which may be due to an excessive amount of liquid in the cylinder.

Another object of the invention is to provide means for returning to the under side of the piston the liquid which may have leaked through between the piston and the cylinder and thereby maintain a substantially constant amount of liquid in the cylinder.

A further object of the invention is the provision of an improved communicating

passage between the cylinder and the diaphragm chamber.

With these and other objects in view, as will more fully hereinafter appear, the invention consists of certain novel features of construction and arrangement of parts hereinafter fully described, illustrated in the accompanying drawings and particularly pointed out in the appended claims, it being understood that various changes in the form, proportions, size and minor details of the structure may be made without departing from the spirit or sacrificing any of the advantages of the invention.

Referring to the drawings: Figure 1 is a vertical section of the pump showing the method of arranging and attaching the improvements of my invention. Fig. 2 is a detail of the liquid reservoir and the latch controlling the movement of the valve handle. Fig. 3 is a cross section of a larger scale of the communicating passage between the cylinder and the diaphragm chamber.

The pump consists of a casing formed of a body 2 and a cover 3 between which is clamped the diaphragm 4. Integral with the cover 3 is the cylinder 5 within which the piston 6 is reciprocated by means of the handle 7 and the connecting links 8-9. The cylinder below the piston is filled with a quantity of liquid, preferably oil, and the downward movement of the piston forces the liquid through the communicating passage 12 against the upper face of the diaphragm 4 which is consequently depressed, with the effect of forcing the liquid in the chamber below the diaphragm out through the discharge port 13. On the upward movement of the piston, the diaphragm is drawn up causing a partial vacuum in the chamber below the diaphragm and a quantity of liquid is drawn in through the inlet port 14.

Heretofore, the communicating passage between the upper part of the diaphragm chamber and the cylinder has generally consisted of a plurality of small holes and the contact of the diaphragm 4 with the edges of these holes has tended to rapidly wear the diaphragm at those points. In this in-

vention I employ a spider 15 having large openings 16 therein through which the liquid may pass with very small friction. To prevent the diaphragm from coming in contact with these large openings 16 and being ruptured by the force of the suction, I provide a vertically moving valve 17, slidable in the spider and seating in a recess 18 therein when in its upper position. As the diaphragm is raised it presses against the valve 17 and moves it to its seat, in which position it covers the openings 16. By this arrangement, the diaphragm bears against a smooth surface and the liability to rupture is overcome.

Another important feature of my invention is the means of filling the cylinder 5 with the required amount of liquid and maintaining that amount of liquid therein. For this purpose I employ the valve 19 communicating with the lower part of the cylinder 5. Mounted on the valve 19 is the receptacle 21 into which the oil or liquid is placed, from whence it passes through the valve 19 into the cylinder. When the proper amount of liquid has been admitted, the valve 19 is closed.

To prevent the valve from being closed at any other time than when the piston is at the bottom of its stroke, I have arranged a latch which holds it locked in the open position. In Fig. 2 I have shown the handle 22 of the valve in the open position. The opposite end 23 of the handle bears against a foot piece 24 on a bifurcated member which straddles the screw on the valve. The position of this foot piece 24 is controlled by the spring held rod 25 which enters the upper part of the casing. The spring 26 normally holds the foot piece in the position indicated, and the valve is locked in the open position. When the piston 6 is at the bottom of its throw, the lug 27 on the link 9 depresses the rod 25 so that the foot piece 24 is moved from the tongue 23 on the handle and the valve may be closed. This arrangement prevents an excessive amount of liquid from being admitted to the cylinder, which on the downward stroke of the piston would force the diaphragm against the port openings and cause its rupture.

By placing a supply of the liquid in the receptacle 21 and opening the valve 19, the amount of liquid in the cylinder may be readily adjusted by reciprocating the piston. As the pump is operated, a quantity of the liquid or oil will force its way behind the piston and to prevent the loss and waste of this liquid I have arranged a small drain pipe 28 leading from the upper part of the cylinder to the receptacle 21. The

oil is not only recovered, but by observing the amount of oil in the receptacle the operator is able to determine whether the amount of oil within the cylinder should be adjusted.

No claim is herein made to the novel features of the construction of the casing of the pump, the arrangement of the diaphragm therein and the manner of supporting the latter herein illustrated and described and which are also disclosed by and form the subject-matter of a prior application Serial No. 565,624 filed June 7, 1910.

I claim:

1. In a pump of the character described, a casing having its interior divided into two chambers by a diaphragm, a cylinder mounted on the casing, a spider provided with openings arranged between the cylinder and the casing, and a plate suspended from the spider adapted to be moved by the diaphragm to cover said openings.

2. In a pump of the character described, a casing having its interior divided into two chambers by a diaphragm, a cylinder communicating with one chamber, a spider having a recessed under face arranged between the cylinder and the chamber, and a plate suspended from the spider and adapted to be moved into said recess by the diaphragm.

3. In a pump of the character described, a casing having its interior divided into two chambers by a diaphragm, a cylinder communicating with one chamber, a piston in said cylinder, a filling valve on the cylinder below the piston and a receptacle mounted on said valve.

4. In a pump of the character described, a casing having its interior divided into two chambers by a diaphragm, a cylinder communicating with one chamber, a piston in said cylinder, a filling valve on the cylinder below the piston, a receptacle mounted on the valve and a conductor connecting the part of the cylinder above the piston with said receptacle.

5. In a pump of the character described, a casing having its interior divided into two chambers by a diaphragm, a cylinder communicating with one chamber, a piston in the cylinder, a filling valve on the cylinder below the piston, and means for preventing the valve from being closed except when the piston is in the lowest position.

6. In a pump of the character described, a casing having its interior divided into two chambers by a diaphragm, a cylinder communicating with one chamber, a piston in the cylinder, a filling valve on the cylinder below the piston, a foot piece held in contact with the handle of the valve, a lug on the piston driving means, and a rod sup-

porting the foot piece adapted to be depressed by the lug when the piston is in the lowest position.

5 7. In a pump of the character described, a casing having its interior divided into two chambers by a diaphragm, a cylinder communicating with one chamber, a piston in the cylinder, a filling valve on the cylinder below the piston, a receptacle on said valve,

a handle for opening the valve and means 10 for preventing the closing of the valve except when the piston is in the lowest position.

JOSEPH MILBURN.

Witnesses:

H. G. PROST,
P. S. PIDWELL.