

(19)



(11)

**EP 1 990 287 A1**

(12)

**EUROPEAN PATENT APPLICATION**

(43) Date of publication:

**12.11.2008 Bulletin 2008/46**

(51) Int Cl.:

**B65D 39/00 (2006.01)**

**B65D 39/04 (2006.01)**

(21) Application number: **07107798.6**

(22) Date of filing: **09.05.2007**

(84) Designated Contracting States:

**AT BE BG CH CY CZ DE DK EE ES FI FR GB GR HU IE IS IT LI LT LU LV MC MT NL PL PT RO SE SI SK TR**

Designated Extension States:

**AL BA HR MK RS**

(72) Inventors:

- **Baggio, Giorgio**  
**35018 San Martino di Lupari (PD) (IT)**
- **Baggio, Giorgia**  
**35018 San Martino di Lupari (PD) (IT)**

(71) Applicant: **Baggio Consulting S.A.S. Di Baggio Giorgio & C.**  
**35018 San Martino Di Lupari PD (IT)**

(74) Representative: **Modiano, Micaela Nadia et al**  
**Dr. Modiano & Associati SpA**  
**Via Meravigli 16**  
**20123 Milano (IT)**

(54) **Stopper particularly for a bottle for containing wine**

(57) A stopper particularly for a bottle (2) for containing wine comprising a body (3) which can be associated within or at the open end of the neck (5) of the bottle (2) so as to close it; at least one block (9) is associated axially and internally with the body (3) and is made of a material which is permeable to air, impermeable to liquids and porous, its ends being connected, directly or by means of at least one duct (12), to the inside and the outside of the bottle (2).

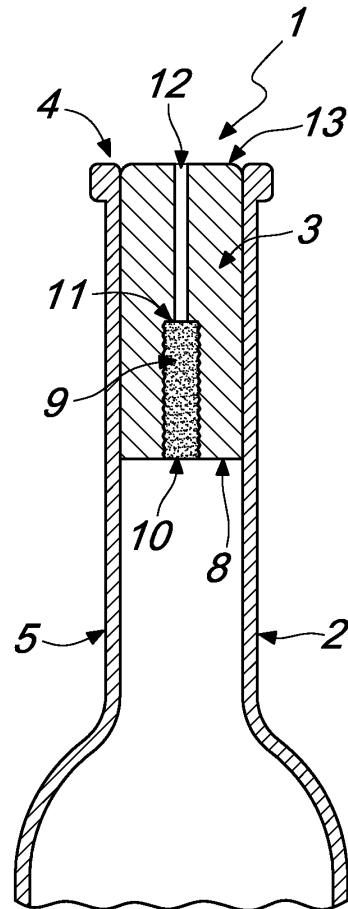

*Fig. 3*

**EP 1 990 287 A1**

## Description

**[0001]** The present invention relates to a stopper particularly for a bottle suitable for containing wine.

**[0002]** Currently, bottles typically made of glass are used particularly to preserve and transport wine and are closed with stoppers.

**[0003]** A first known type of stopper consists of a small cylinder, obtained from a single piece of cork, which is slightly larger in diameter than the neck of the bottle, so that it can be inserted therein following radial compression.

**[0004]** Once it has been thus inserted in the open end of the neck of the bottle, the cylinder tends to expand radially, adhering to the internal surface of the bottle and accordingly closing it.

**[0005]** Due to the material of which it is made, the cylinder is crossed by small irregularly-shaped cavities, which connect the inside of the bottle to the outside and allow a minimal exchange of air; this is essential in particular for wines that must undergo an aging process in a bottle.

**[0006]** The cavities or natural channels that pass through the cork further form, in certain portions, receptacles for a substance, known as suberin, which has antibacterial properties which limit the formation of bacteria, molds or fungi, which might cause deterioration of the wine.

**[0007]** These known types of stopper, obtained from a single piece of cork, have a drawback: the characteristics of air-permeability of the stopper depend directly on the quality of the cork, which being a natural element is subject to many environmental factors that are difficult to control; in particular, the characteristics of the cork depend on the location and on the level of growth attained by the plant, on the climate conditions in which it has grown, on any fungi, molds or bacteria that might have attacked it, and on the detergents used to wash the cork to make it adapted for contact with wine.

**[0008]** Therefore, the characteristics of these known types of stopper cannot be determined easily beforehand, with the consequent risk of not ensuring perfect preservation of the wine and/or the uniformity of the aging process of a same wine contained in several bottles closed by different stoppers.

**[0009]** Further, the enormous number of bottles of wine produced each year has caused a drastic reduction in the quantity of cork available, in particular of pieces of cork large enough to provide the stoppers described earlier.

**[0010]** Stoppers are also known which are constituted by a small cylinder obtained from a plurality of small cork cylinders which have a same radius and a reduced height and are arranged one above the other and fixed axially to each other by means of a suitable adhesive; in this manner, it is possible to obtain stoppers starting from cork pieces which are smaller and are therefore available in larger quantities.

**[0011]** These known types of stopper, however, have the drawback that their permeability to air is extremely reduced by the presence of the adhesive, which can also cause the deterioration of the wine contained in the bottle.

**[0012]** In order to be able to use even small cork fragments, or to reuse pieces of cork stoppers that have already been used, for the production of stoppers, stoppers are known which are constituted by a small cylinder obtained by pressing and monolithically coupling small cork pieces by means of appropriate adhesives.

**[0013]** However, even these known types of stopper have, due to the presence of the adhesive, a reduced air permeability, and there is also the risk that the adhesive agent might cause deterioration of the wine.

**[0014]** In an attempt to overcome the problem of the limited availability of cork, it is known to provide stoppers constituted by a small cylinder made of an elastically deformable plastic material, which is generally silicone-based and is inserted, after radial compression, in the open end of the neck of the bottle to be closed; however, said known types of stopper are completely airtight and therefore cannot be used for wines that need to age in the bottle.

**[0015]** Again as an alternative to cork stoppers, stoppers are also in use which are made of rigid or semirigid plastics, glass, or ceramics and comprise a substantially cylindrical or frustum-shaped stem, from the lateral surface of which annular ribs protrude in some cases; the stem is inserted, optionally with the interposition of suitable gaskets, in the open end of the neck of a bottle, so as to rigidly couple by friction to the internal surface of the neck and close the bottle.

**[0016]** However, even these known types of stopper have the drawback that they are completely airtight and do not ensure protection of the wine against bacteria, molds or fungi.

**[0017]** As a partial solution to these drawbacks, WO02/055397 discloses a stopper, particularly for wine bottles, which comprises a small cylinder made at least partially of synthetic material, such as for example a polyethylene resin with the addition of an expanding agent, which can be inserted by pressing in the neck of a bottle so as to close it; at least one tubular duct is formed within the cylinder and connects the inside of the bottle to the outside environment through at least one membrane, which is permeable to oxygen but impermeable to liquids and is arranged transversely with respect to the duct.

**[0018]** The membrane is constituted by a film made of an acrylic copolymer and is fixed to an appropriately provided substrate made for example of non-woven fabric.

**[0019]** Optionally, the membrane can be fixed inside a small cylindrical tube arranged coaxially with respect to the tubular duct.

**[0020]** Although this known embodiment allows to obtain a chosen exchange of the air between the outside environment and the wine, it provides no protection to the wine against the formation of molds, fungi or bacteria that might cause its deterioration.

**[0021]** Further, the membrane, made of synthetic material, over time may release chemical substances which might cause deterioration of the wine.

**[0022]** Further, the membrane, over time, can lose its characteristics of air-permeability and/or impermeability to liquids, with the consequent risk of causing deterioration of the wine and/or allowing its leakage from the bottle.

**[0023]** Moreover, if the bottle is inverted, the wine enters the duct formed within the cylinder, thus making contact with the membrane; such membrane, being very thin, may break under the pressure of the wine, causing the wine to leak from the bottle.

**[0024]** The aim of the present invention is to solve the above-mentioned problems, eliminating the drawbacks of the cited background art, by providing a stopper that allows to close in particular a bottle of wine, so as to prevent the leakage of said wine, at the same time ensuring a chosen exchange of air between the inside of the bottle and the outside environment.

**[0025]** Within this aim, an object of the invention is to provide a stopper which allows to close in particular a bottle of wine so as to reduce the formation of molds, fungi or bacteria.

**[0026]** Another object is to provide a stopper which can be obtained in a chosen quantity and has constant air-permeability characteristics.

**[0027]** Another object of the invention is to ensure that the wine does not leak from the bottle even if the bottle is inverted.

**[0028]** Another object is to provide a stopper which is structurally simple and has low manufacturing costs.

**[0029]** This aim and these and other objects, which will become better apparent hereinafter, are achieved by a stopper particularly for a bottle for containing wine, which comprises a body which can be associated within or at the open end of the neck of said bottle so as to close it, characterized in that at least one block is associated axially and internally with said body and is made of a material which is permeable to air, impermeable to liquids and porous, its ends being connected, directly or by means of at least one duct, to the inside and the outside of said bottle.

**[0030]** Further characteristics and advantages of the invention will become better apparent from the following detailed description of a particular but not exclusive embodiment thereof, illustrated by way of non-limiting example in the accompanying drawings, wherein:

Figure 1 is a sectional view, taken along a diametrical plane, of the neck of a bottle to which the stopper is applied, and of the stopper according to the present invention;

Figures 2 to 9 are views, similar to Figure 1, of further embodiments of the invention;

Figures 10 to 17 are various views of further embodiments of the invention.

**[0031]** In the exemplary embodiments that follow, in-

dividual characteristics, given in relation to specific examples, may actually be interchanged with other different characteristics that exist in other exemplary embodiments.

**[0032]** Moreover, it is noted that anything found to be already known during the patenting process is understood not to be claimed and to be the subject of a disclaimer.

**[0033]** With reference to Figures 1, 2 and 3, the reference numeral 1 designates a stopper, particularly for a bottle 2, which comprises a substantially cylindrical body 3, which can be associated with an open end 4 of a neck 5 of the bottle 2 so as to close it.

**[0034]** In the embodiment shown in Figure 1, the body 3 is constituted by a plurality of small cylinders 6, preferably made of cork, which have a same radius and approximately a same height and are arranged one on top of the other and joined together by means of a suitable adhesive.

**[0035]** In the embodiment shown in Figure 2, the body 3 is instead constituted by a plurality of fragments 7, which are preferably made of cork and are suitably pressed and mutually joined by means of a suitable adhesive.

**[0036]** In the embodiment shown in Figure 3, the body 3 is made of an elastically deformable plastic material, such as for example a silicone resin.

**[0037]** Preferably starting from the lower end face 8 of the body 3, which during use is directed toward the inside of the bottle 2, advantageously but not necessarily there is, at the central axis of the body 3, a cavity or receptacle 50, which is at most as high as the body 3.

**[0038]** At least one complementarily shaped block 9, made of a material which is permeable to air, impermeable to liquids and porous, is associated within the cavity or receptacle 50, which is advantageously approximately cylindrical.

**[0039]** In the embodiments shown in Figures 1, 2 and 3, the cavity or receptacle 50 and the block 9 contained therein are not as high as the body 3 and are arranged so that a first end 10 of the block 9 is connected directly, during use, to the inside of the bottle 2.

**[0040]** Advantageously, a second end 11 of the block 9 is connected to at least one duct 12, which is preferably but not necessarily approximately cylindrical and is formed in the body 3 starting from its upper end face 13, which lies opposite the lower end face 8.

**[0041]** In another embodiment, the body 3 can be associated with the neck 5 of the bottle 2 by turning it through 180°, so that the block 9 is directly connected to the outside of the bottle 2 (environment).

**[0042]** As an alternative, the cavity or receptacle 50 and the block 9 contained therein may be as high as the body 3, so that the first and second ends of said block are connected directly respectively to the inside and the outside of the bottle 2; in this case, not shown in the accompanying figures, the cavity or receptacle 50, and therefore the block 9, are arranged in a position which is

axial but axially offset with respect to the longitudinal central axis of the body 3, so as to allow the insertion, approximately centrally with respect to the upper end face 13, of the tip of a corkscrew which is adapted to extract the stopper 1 from the bottle 2.

**[0043]** Advantageously but not necessarily, the outer lateral surface of the block 9 is knurled, so as to improve its grip on the lateral surface of the cavity or receptacle 50 within which it is accommodated.

**[0044]** Advantageously, the block 9 can be obtained for example by sintering a material which has such characteristics as not to cause the wine to deteriorate, such as for example stainless steel, glass or ceramics.

**[0045]** Sintering entails the compression, in an appropriate mold, of a powder of the intended material, optionally with the addition of suitable additives, and then heating it to a temperature which is close to its melting point but such as not to change the shape of the particles; interspaces of appropriate sizes are thus formed among the various particles and allow the flow of air.

**[0046]** The dimensions of the interspaces depend on the type of material used, on the pressure with which the particles are compacted, and on the temperature to which they are subjected; by adjusting these factors appropriately, therefore, it is possible to obtain interspaces of chosen dimensions, such as to allow the flow of a chosen amount of air but at the same time prevent the passage of wine.

**[0047]** Advantageously, the powder to be sintered can be enriched with a selected percentage of powder of silver or of other materials having antibacterial characteristics, such as for example titanium oxide; this helps to prevent the formation of molds, fungi or bacteria, which might cause the wine to deteriorate.

**[0048]** Advantageously, in a chosen region of the block 9, the interspaces that are present among the various particles that constitute the sintered material can be filled with a bactericidal substance which does not cause the wine to deteriorate, such as for example suberin, which can be obtained from cork.

**[0049]** As an alternative, the block 9 can be provided for example by means of a solid metallic foam, which has a porous structure; it is therefore possible to predetermine the dimensions of the pores so that they can be crossed by the air but not by a liquid such as wine.

**[0050]** In this case also, in a chosen region of the block 9 the pores that are present therein can be filled with a bactericidal substance which does not cause the wine to deteriorate, such as for example suberin.

**[0051]** Operation is therefore as follows: with reference to Figures 1, 2 and 3, the lateral surface of the body 3 is compressed radially and then inserted in the open end 4 of the neck 5 of the bottle 2.

**[0052]** Once inserted in the neck 5, the body 3 tends to expand radially, adhering to the internal surface of the neck 5 and thus closing the bottle 2.

**[0053]** Air can pass through the body 3 and enter or exit from the bottle 2 through the duct 12 and the block

9; the flow-rate of the air that passes through the body 3 is determined by the dimensions of the interspaces or pores that are present in the block 9.

**[0054]** It has thus been found that the invention has achieved the intended aim and objects, a stopper particularly for a bottle for containing wine having been provided which allows to close said bottle in order to prevent the outflow of the wine, at the same time ensuring the chosen exchange of air between the inside of the bottle and the outside environment.

**[0055]** The possibility to obtain a block which has interspaces or pores of chosen and predefined dimensions further allows to ensure the perfect preservation and/or aging of the wine.

**[0056]** Further, it is possible to achieve easily a chosen quantity of stoppers according to the invention having the chosen characteristics of air-permeability, so as to meet the requirement of closing the very large number of bottles produced each year.

**[0057]** It is also easy to produce a chosen number of stoppers according to the invention, all of which have substantially the same characteristics of air-permeability, so as to ensure, for example, uniformity of the aging process of a same wine contained in several bottles closed by said stoppers.

**[0058]** Further, the possibility to introduce a percentage of silver or other materials having antibacterial characteristics in the composition of the block helps to prevent the formation of molds, fungi or bacteria which might cause the wine to deteriorate.

**[0059]** Moreover, the possibility to impregnate a chosen region of the block with a bactericidal substance which does not cause wine deterioration further helps to reduce the formation of molds, fungi or bacteria.

**[0060]** Further, the block is very solid and therefore does not run the risk of breaking or separating under the weight of the wine which might press thereon if, for example, the bottle is inverted.

**[0061]** Finally, the production costs of the stopper according to the invention remain low, since the stopper is made of components that are easy to produce and/or assemble.

**[0062]** The invention is of course susceptible of numerous modifications and variations, all of which are within the scope of the appended claims.

**[0063]** Thus, for example, with reference to Figures 4, 5 and 6, a stopper 101 is shown, particularly for a bottle 102, which comprises a body 103 which is substantially T-shaped and has a head 114 which is substantially cylindrical and from which a stem 115 protrudes which can be inserted in the open end 104 of the neck 105 of the bottle 102.

**[0064]** In the embodiment shown in Figure 4, the body 103 is made of a rigid or semirigid plastic material; annular ridges 116 protrude from the lateral surface of the stem 115, which is likewise substantially cylindrical, and are adapted to adhere by pressure to the internal surface of the neck 105 of the bottle 102.

**[0065]** In the embodiment shown in Figure 5, the body 103 is advantageously made of glass, ceramics or rigid plastic material, and has a substantially frustum-shaped stem 115, in which the smaller end face is directed toward the inside of the bottle 102; in this case, the neck 105 of the bottle 102 is shaped complementarily with respect to the stem 115 of the body 103, so that its internal lateral surface is approximately parallel to the external lateral surface of the stem 115, so as to allow the mutual engagement of said surfaces and the fixing by friction of the stem 115 in the neck 105.

**[0066]** In the embodiment shown in Figure 6, the body 103 is again made of glass, ceramics or rigid plastic material, and has a substantially frustum-shaped stem 115, in which the smaller end face is directed toward the inside of the bottle 102 and the larger end face has a smaller diameter than the inside diameter of the neck 105 of the bottle 102; the seal between the stem 115 and the internal surface of the neck 105 in this case is obtained by means of a suitable substantially annular first gasket 117, which is arranged coaxially and externally with respect to the stem 115, adjacent to and below the head 114.

**[0067]** With reference to Figures 4, 5 and 6, preferably starting from the upper end face 113 of the head 114 of the body 103, there is advantageously but not necessarily, at the central axis of the head 114, a cavity or receptacle 150, which is at most as high as the body 103.

**[0068]** At least one complementarily shaped block 109 is associated within the cavity or seat 150 and is made of a material which is permeable to air, impermeable to liquids and porous.

**[0069]** With reference to Figures 4, 5 and 6, the cavity or seat 150 and the block 109 contained therein are not as high as, i.e. lower than, the body 103; a first end 110 of the block 109 is directed, during use, toward the inside of the bottle 102 and is connected to at least one duct 112, which is advantageously but not necessarily approximately frustum-shaped and is formed in the body 103 starting from the lower end face 108 of the stem 115 thereof to the receptacle or cavity 150.

**[0070]** In the embodiments shown in Figures 4, 5 and 6, the second end 111 of the block 109 is arranged flush with the upper end face 113 of the head 114 of the latter.

**[0071]** As an alternative, in another embodiment, not shown in the accompanying figures, the cavity or receptacle 150 and the block 109 contained therein have a same height, which is equal to the height of the body 103, so that the first and second ends of the block 109 are connected directly respectively to the inside and to the outside of the bottle 102.

**[0072]** Advantageously, as in the embodiments described earlier with reference to Figures 1, 2 and 3, the block 109 can be obtained for example by sintering a material which has such characteristics as not to cause wine to deteriorate, such as for example stainless steel, glass or ceramics, and the powder to be sintered can optionally be enriched with a chosen percentage of a material which has antibacterial characteristics.

**[0073]** As an alternative, in this case also the block 109 can be made for example of a solid metallic foam, which has a porous structure, and a chosen region of the block 109 can be impregnated with a bactericidal substance which does not cause wine to deteriorate.

**[0074]** With reference to Figure 7, a stopper 201, particularly for a bottle 202, is shown which comprises a body 203 which is approximately T-shaped and is provided with a substantially cylindrical head 214 from which a stem 215 protrudes, said stem being likewise approximately cylindrical or frustum-shaped and being partially insertable in the open end 204 of the neck 205 of the bottle 202.

**[0075]** A second annular gasket 219 is interposed between the head 214 of the body 203 and the perimetric edge of the end 204 of the neck 205 of the bottle 202 and is arranged coaxially and externally with respect to the stem 215.

**[0076]** Advantageously, a suitable lever 220 of a known type is rotatably associated with the head 214 and with the neck 205 and is adapted to compress selectively the head 214 toward the neck 205, so as to couple the stopper 202 thereto.

**[0077]** Preferably starting from the lower end face 208 of the stem 215 of the body 203 there is, advantageously but not necessarily, at the central axis of the stem 215, a cavity or receptacle 250, which is at most as high as the body 203.

**[0078]** At least one complementarily shaped block 209, made of a material which is permeable to air and impermeable to liquids and porous, is associated within the cavity or receptacle 250.

**[0079]** With reference to Figure 7, the cavity or receptacle 250 and the block 209 contained therein are not as high as the body 203; a first end 210 of the block 209 is connected directly to the inside of the bottle 202, while a second end 211 thereof is connected to at least one duct 212, which is advantageously but not necessarily approximately cylindrical and is formed axially with respect to the body 203 starting from the upper end face 213 of the head 214.

**[0080]** In a further embodiment not shown in the accompanying figures, the cavity or receptacle 250 and the block 209 contained therein are again lower than the body 203 and are arranged so that the second end 211 of the block 209 is flush with the upper end face 213 of the stem 214, thus being connected directly to the outside of the bottle 202; in this case, the first end 210 of the block 209 is connected to at least one duct, which passes axially through the body 203 starting from the lower end face 208 of the stem 212 thereof up to the cavity or receptacle 250.

**[0081]** As an alternative, in another embodiment not shown in the accompanying figures, the cavity or seat 250 and the block 209 contained therein are as high as the block 203, and therefore the first and second ends of the block 209 are connected directly to the inside and outside of the bottle 202 (environment), respectively.

**[0082]** With reference to Figures 8 and 9, a stopper 301 particularly for a bottle 302 is shown which comprises a body 303 constituted by a disk 321, which has a substantially circular plan shape and can be positioned on the free end 304 of the neck 305 of a bottle 302 in order to close it, with the optional interposition of a suitable third gasket 322, which is advantageously annular.

**[0083]** An annular tab 323 protrudes from the perimetric edge of the disk 321 toward the neck 305 of the bottle 302 so as to partially surround it.

**[0084]** In the embodiment shown in Figure 8, the disk 321 and the annular tab 323 are advantageously metallic, and said tab can be pressed radially toward the neck 305 so as to undergo a permanent deformation and be rigidly coupled to a suitable annular protrusion 324, which protrudes radially from the outer lateral surface of the neck 305 at the open end 304 thereof; in this manner, it is possible to obtain a stopper of the type known commonly as crown cap.

**[0085]** In the embodiment shown in Figure 9, the annular tab 323 is advantageously threaded internally, so that it can engage a thread 325 which protrudes from the outer surface of the neck 305 of the bottle 302 at the open end 304 thereof; in this manner it is possible to obtain a stopper of the type commonly known as screw cap.

**[0086]** Approximately centrally with respect to the disk 321, toward the inside of the bottle 302, there is an axial cavity or receptacle 350 which is approximately U-shaped and on the bottom of which there is at least one first hole which forms a duct 312.

**[0087]** An approximately complementarily shaped block 309, similar to the blocks described earlier with reference to Figures 1 to 7, can be accommodated in the cavity or receptacle 350.

**[0088]** The block 309 is connected to the inside of the bottle 302 through the duct 312.

**[0089]** As an alternative, the bottom of the cavity or receptacle 350 can be completely open, so that the block 309, rigidly coupled beforehand to the cavity or receptacle 350, is connected directly to the inside and the outside of the bottle 302.

**[0090]** In the embodiment shown in Figure 8, the second end 311 of the block 309 is connected directly to the environment outside the bottle 302.

**[0091]** With reference to Figures 10 and 11, a stopper 401, particularly for a bottle, is shown which comprises a body 403 constituted by a disk 421 which has a substantially circular plan shape, is advantageously made of metal, and from the perimetric edge of which an annular tab 423 protrudes toward the neck 405 of the bottle so as to partially wrap around it.

**[0092]** In the embodiment shown in Figure 10, the annular tab 423 can be pressed radially toward the neck 405 so as to undergo a permanent deformation and be rigidly coupled to a suitable annular protrusion 424, which protrudes radially from the outer lateral surface of the neck 405 at the open end thereof; in this manner, it is possible to obtain a stopper of the type known commonly

as crown cap.

**[0093]** In the embodiment shown in Figure 11, the annular tab 423 is instead advantageously threaded internally, so that it can engage a thread 425 which protrudes from the outer surface of the neck 405 of the bottle at the open end thereof; in this manner it is possible to obtain a stopper of the type commonly known as screw cap.

**[0094]** Advantageously, a second hole 426 is provided in the disk 421, preferably approximately centrally thereto.

**[0095]** The body 403 comprises a fourth gasket 427, which is associated in a lower region with respect to the disk 421 and is interposed during use between said disk and the open end of the neck 405 of the bottle.

**[0096]** Advantageously, the fourth gasket 427 is approximately W-shaped in a cross-section taken along a diametrical plane, so as to form a central portion 428 which is preferably approximately cylindrical and hollow, is open in a lower region and faces the second hole 426 formed in the overlying disk 421.

**[0097]** Two approximately S-shaped wings 429a and 429b protrude radially from the lower end of the central portion 428, and their free ends are interposed, during use, between the open end of the neck 405 of the bottle and the disk 421.

**[0098]** Advantageously, the fourth gasket 427 is made of elastically deformable plastic material.

**[0099]** An axial and preferably cylindrical cavity or receptacle 450 is formed within the central portion 428 of the fourth gasket 427, on the opposite side with respect to the disk 421, and at least one first hole, which forms a duct 412, is formed in the bottom of said cavity or receptacle.

**[0100]** The cavity or receptacle 450 can accommodate an approximately complementarily shaped block 409, which is similar to the blocks described previously with reference to Figures 1 to 9.

**[0101]** The block 409 is connected directly, with its first lower end 410, to the inside of the bottle; the second upper end of the block 409 is connected to the outside of the bottle through the duct 412 and the second hole 426.

**[0102]** As shown in Figures 12 and 13, it is possible to apply a stopper 401 similar to the one shown in Figure 11 to a container 430 of the type made for example by Tetra-Pak for packaging liquid products instead of a bottle.

**[0103]** In the embodiment shown in Figures 12 and 13, in a first upper surface 431 of the container 430 there is a third preferably circular hole 432, to the perimetric edge of which an appropriately provided substantially cylindrical inlet 433 is fixed, said inlet being externally threaded complementarily with respect to the annular tab 423 which protrudes from the disk 421, so that it can be associated with the inlet 433 by screwing.

**[0104]** With reference to Figures 14 and 15, a stopper 501, particularly for a bottle, is shown in which the central portion 528 of a fourth gasket designated as 527 pro-

trudes with its upper end to an appropriately provided complementarily shaped cavity, not shown in the accompanying figures, which is formed in the overlying disk 521, so that the duct 512 formed in the bottom of the cavity or receptacle 550 in which the block 509 is accommodated is connected directly to the outside environment.

[0105] Figure 14 illustrates the case of a stopper of the type commonly known as crown cap, while Figure 15 illustrates the case of a stopper of the type commonly known as screw cap.

[0106] With reference to Figures 16 and 17, an application of the invention to a substantially cylindrical can 634, made for example of aluminum, is shown.

[0107] In this embodiment, the body 603 is constituted by a fifth gasket 635, which is fixed within an appropriately provided opening 636 which is formed in a second upper surface 637 of the can 634.

[0108] Advantageously, the fifth gasket 635 is substantially cylindrical and hollow and open in a lower region, and has, on its lateral surface, adapted means for nonremovable fixing to the second upper surface 637 of the can 634, which are constituted preferably by appropriately provided wings 638a, 638b, which protrude radially from said lateral surface.

[0109] Advantageously, the fifth gasket 635 is made of elastically deformable plastic material.

[0110] A preferably cylindrical axial cavity or receptacle 650 is formed within the fifth gasket 635 toward the inside of the can 634, and at least one first hole which forms a duct 612 is formed in its bottom.

[0111] An approximately complementarily shaped block 609, similar to the blocks described previously with reference to Figures 1 to 15, can be accommodated within the cavity or receptacle 650.

[0112] The block 609 is connected directly, by means of its first lower end 610, to the inside of the can 637, while the second upper end of the block 609 is connected to the outside of the can 634 by means of the duct 612.

[0113] Advantageously, the block made of a material which is permeable to air, impermeable to liquids and porous can be made of a plastic material which has such characteristics, such as for example a plastic material of the polyolefin family; optionally, it is possible to add to the mixture of the plastic material that constitutes the block a bactericidal substance which does not cause the wine to deteriorate, such as for example a percentage of silver.

[0114] The density of the plastic material must be calibrated appropriately so as to achieve such an air permeability as to allow optimum micro-oxygenation of the wine, comparable to that of cork, adapted for maturation and proper preservation of the wine.

[0115] The materials used and the dimensions that constitute the individual components of the invention may of course be more pertinent according to specific requirements.

[0116] The various means for performing certain dif-

ferent functions need not certainly coexist only in the illustrated embodiment but can be present per se in many embodiments, including ones that are not illustrated.

[0117] The characteristics indicated as advantageous, convenient or the like may also be omitted or be replaced with equivalents.

[0118] Where technical features mentioned in any claim are followed by reference signs, those reference signs have been included for the sole purpose of increasing the intelligibility of the claims and accordingly, such reference signs do not have any limiting effect on the interpretation of each element identified by way of example by such reference signs.

## Claims

1. A stopper particularly for a bottle for containing wine, comprising a body (3) which can be associated within or at the open end (4) of the neck (5) of said bottle (2) so as to close it, **characterized in that** at least one block (9) is associated axially and internally with said body (3) and is made of a material which is permeable to air, impermeable to liquids and porous, its ends being connected, directly or by means of at least one duct (12), to the inside and the outside of said bottle (2).
2. The stopper according to claim 1, **characterized in that** in said body (3) there is a cavity or receptacle (50), which is at most as high as said body (3), within which said block (9) is associated.
3. The stopper according to claims 1 and 2, **characterized in that** said cavity or receptacle (50) is formed starting from the lower end face (8) of said body (3), which during use is directed toward the inside of said bottle (2), so that a first end (10) of said block (9) is connected directly, during use, to the inside of said bottle (2).
4. The stopper according to claims 1 and 3, **characterized in that** said cavity or receptacle (50) and said block (9) are lower than said body (3), a second end (11) of said block (9) being connected to said at least one duct (12), which is formed in said body (3) starting from its upper end face (13), which is arranged opposite said lower end face (8).
5. The stopper according to claims 1 and 4, **characterized in that** said body (3) can be associated with the neck (5) of said bottle (2) turned through 180°, so that said block (9) is connected directly, during use, to the outside of said bottle (2).
6. The stopper according to claims 1 and 3, **characterized in that** said cavity or receptacle (50) and said block (9) are as high as said body (3), so that

- said first and second ends (10;11) of said block (9) are connected directly to the inside and the outside of said bottle (2), respectively.
7. The stopper according to one or more of the preceding claims, **characterized in that** said cavity or receptacle (50), and therefore said block (9), are arranged in a position which is axial but axially offset with respect to the longitudinal central axis of said body (3). 5
  8. The stopper according to one or more of the preceding claims, **characterized in that** the outer lateral surface of said block (9) is knurled, so as to improve its grip on the lateral surface of said cavity or receptacle (50) within which it is accommodated. 10
  9. The stopper according to one or more of the preceding claims, wherein said body (103) is approximately T-shaped, so as to form a substantially cylindrical head (111) from which a likewise cylindrical stem (115) protrudes which can be inserted in said neck (105) of said bottle (102), wherein said cavity or receptacle (150) is formed at the central axis of said head (111) and is at most as high as said body (103), at least one complementarily shaped block (109) being associated within said cavity or receptacle (150). 15
  10. The stopper according to claims 1 and 9, **characterized in that** said cavity or receptacle (150) and said block (109) contained therein are lower than said body (103), said first end (110) of said block (109) being directed, during use, toward the inside of said bottle (102) and being connected to said at least one duct (112), which is formed in said body (103) starting from the lower end face (108) of said stem (115) to said receptacle or cavity (150), said second end (111) of said block (109) being arranged flush with said upper end face (113) of said head (114). 20
  11. The stopper according to claims 1 and 9, **characterized in that** said cavity or receptacle (150) and said block (109) contained therein are as high as said body (103), said first and second ends of said block (109) being connected directly to the inside and the outside of said bottle (102), respectively. 25
  12. The stopper according to claims 1 and 9, **characterized in that** said cavity or receptacle (250) and said block (209) contained therein are lower than said body (203), said first end (210) of said block (209) being connected directly to the inside of said bottle (202), said second end (211) of said block (209) being connected to said at least one duct (212), which is formed axially with respect to said body (203) starting from said upper end face (213) of said head (214). 30
  13. The stopper according to one or more of the preceding claims, wherein said body is constituted by a disk (321) which is substantially circular in plan shape and can be positioned on the free end (304) of said neck (305) of said bottle (302) in order to close it, an annular tab (323) protruding from the perimetric edge of said disk (321) toward said neck (305) and so as to partially wrap around it, wherein said axial and approximately U-shaped cavity or receptacle (350) is formed approximately centrally with respect to said disk (321), toward the inside of said bottle (302), at least one first hole being formed in the bottom thereof, said hole forming said at least one duct (312) within which said block (309) can be accommodated, said block being shaped approximately complementarily with respect to said cavity or receptacle (350). 35
  14. The stopper according to claims 1 and 13, **characterized in that** said bottom of said cavity or receptacle (350) is completely open, so that said block (309), rigidly coupled beforehand to said cavity or receptacle (350), is connected directly to the inside and the outside of said bottle (302). 40
  15. The stopper according to one or more of the preceding claims, **characterized in that** said block (9) is obtained by sintering a material which has such characteristics as not to cause deterioration of wine, such as stainless steel, glass or ceramics. 45
  16. The stopper according to claims 1 and 15, **characterized in that** the block (9) is formed in sintered powder that is enriched with a selected percentage of powder of silver or of other materials having antibacterial characteristics, such as titanium oxide. 50
  17. The stopper according to claims 1 and 16, **characterized in that**, in a selected region of said block (9), the interspaces that are present among the various particles that constitute the sintered material are filled with a bactericidal substance which does not cause wine deterioration. 55
  18. The stopper according to one or more of the preceding claims, **characterized in that** said block (9) is made of a solid metallic foam which has a porous structure.
  19. The stopper according to claims 1 and 18, **characterized in that** in a selected region of said block (9) the pores that are present therein are filled with a bactericidal substance which does not cause wine deterioration.
  20. The stopper according to claim 1, **characterized in that** said body (403) is constituted by a disk (421), which has a substantially circular plan shape and in which a second hole (426) is formed, and by a fourth

- gasket (427), which is associated in a lower region with respect to said disk (421) and has, in a cross-section taken along a diametrical plane, an approximately W-shaped configuration so as to form a central portion (428), which is preferably approximately cylindrical, hollow and open downward and faces said second hole of said disk (421), two approximately S-shaped wings (429a, 429b) protruding radially from the lower end of said central portion (428), their free ends being interposed, during use, between said disk and the open end of said neck (405) of said bottle (402).
21. The stopper according to claims 1 and 20, **characterized in that** said preferably cylindrical axial cavity or receptacle (450) is formed within said central portion (428) of said fourth gasket (427), on the opposite side with respect to said disk (421), at least one first hole being formed in the bottom of said cavity or seat and forming said duct (412), said block (409) being accommodatable within said cavity (450).
22. The stopper according to claims 1 and 21, **characterized in that** said fourth gasket (427) is made of elastically deformable plastic material.
23. The stopper according to one or more of the claims 20-22, **characterized in that** it is associable with a container (430) such as those made for example by Tetra-Pak and has, in a first upper surface thereof, a preferably circular third hole (432), to the perimetric edge of which an appropriately provided substantially cylindrical inlet (433) is fixed, said inlet being threaded externally complementarily with respect to an annular tab (423) which is threaded internally and protrudes downward from said disk (421), so that it can be associated with said inlet (433) by screw coupling.
24. The stopper according to one or more of the claims 20-23, **characterized in that** said central portion of said fourth gasket (527) protrudes with its upper end through an appropriately provided complementarily shaped cavity formed within said overlying disk (521), so that said duct (512) provided in said bottom of said cavity or receptacle (550) is connected directly to the outside environment.
25. The stopper according to one or more of the claims 20-24, **characterized in that** said body (603) is constituted by a fifth gasket (635), which is fixed within an appropriately provided opening (636) formed in a second upper surface (637) of a can (634).
26. The stopper according to claims 1 and 25, **characterized in that** said fifth gasket (635) is substantially cylindrical and hollow and open in a lower region, and has, on its lateral surface, appropriately provided means (63 8a, 63 8b) for nonremovable fixing to said second upper surface (637) of said can (634).
27. The stopper according to claims 1 and 26, **characterized in that** said nonremovable fixing means are constituted by appropriately provided wings (63 8a, 63 8b) which protrude radially from said lateral surface of said fifth gasket (635).
28. The stopper according to claims 1 and 27, **characterized in that** said cavity or receptacle (650) in which said block (609) can be accommodated is formed within said fifth gasket (635) toward the inside of said can (634).
29. The stopper according to claims 1 and 28, **characterized in that** said fifth gasket (635) is made of elastically deformable plastic material.
30. The stopper according to one or more of the claims 25-29, **characterized in that** said block (609) is made of a plastic material which is permeable to air and impermeable to liquids.
31. The stopper according to claims 1 and 30, **characterized in that** said block (609) is made of a plastic material of the polyolefin family.
32. The stopper according to claims 1 and 31, **characterized in that** a bactericidal substance, such as to not cause deterioration of the wine, is added in the mixture of said plastic material.

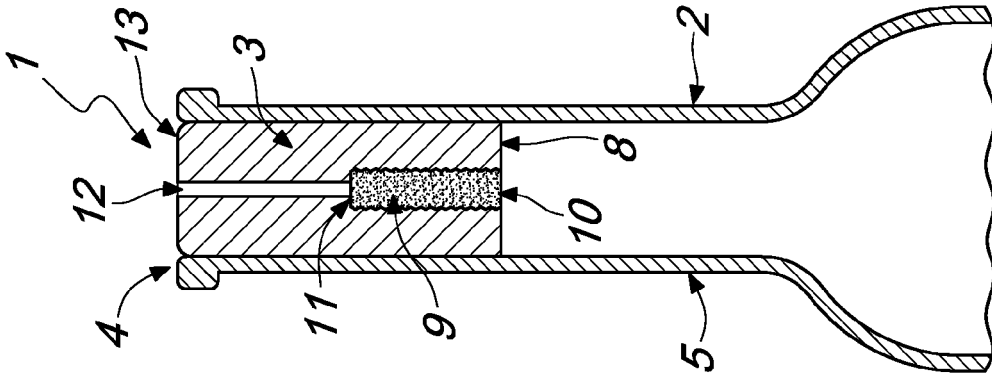

Fig. 1

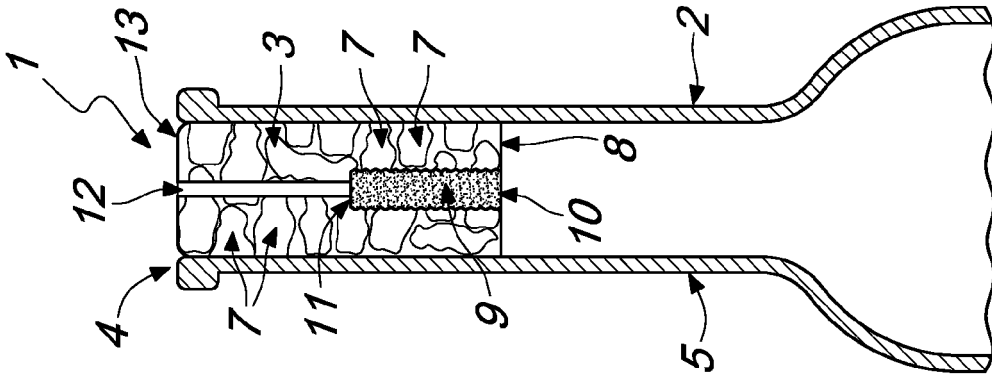

Fig. 2

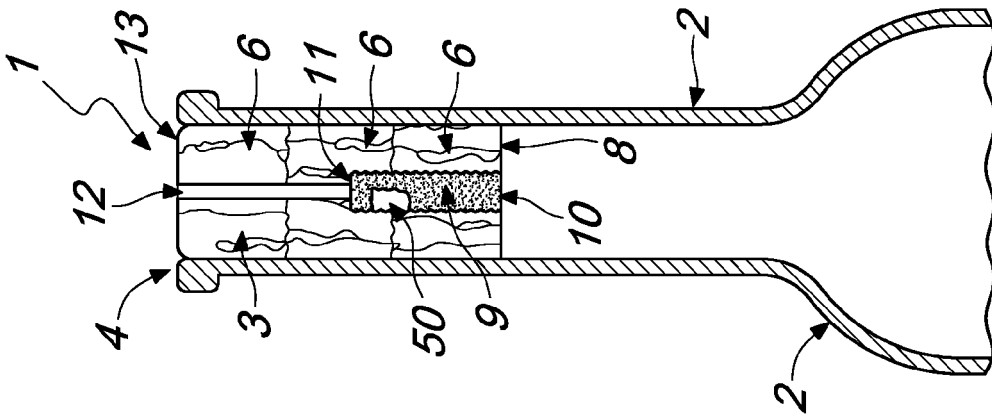

Fig. 3

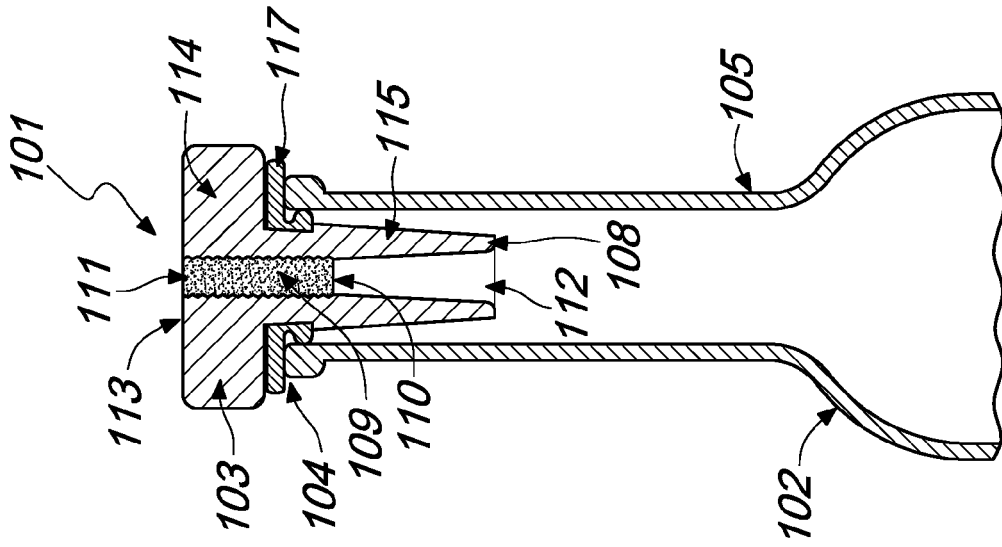

Fig. 6

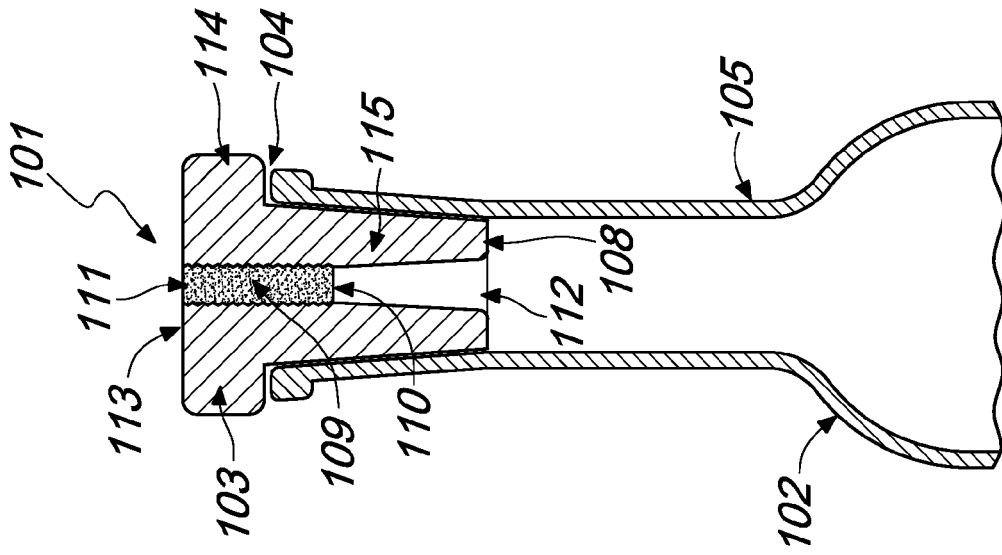

Fig. 5

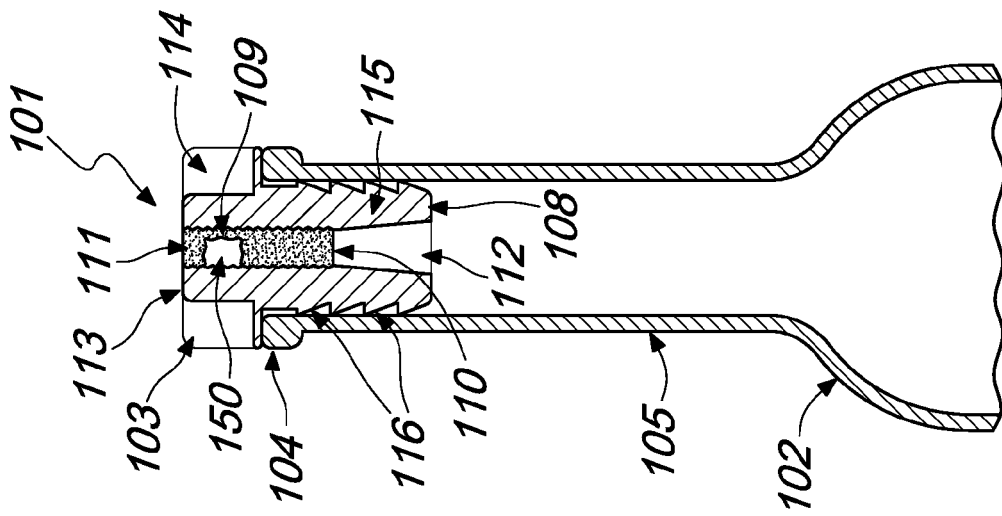

Fig. 4

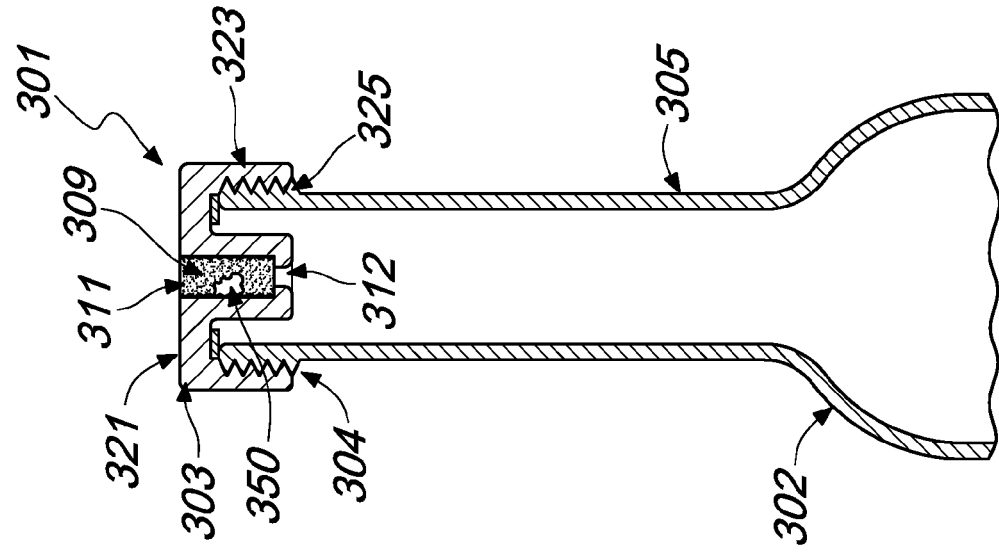

Fig. 9

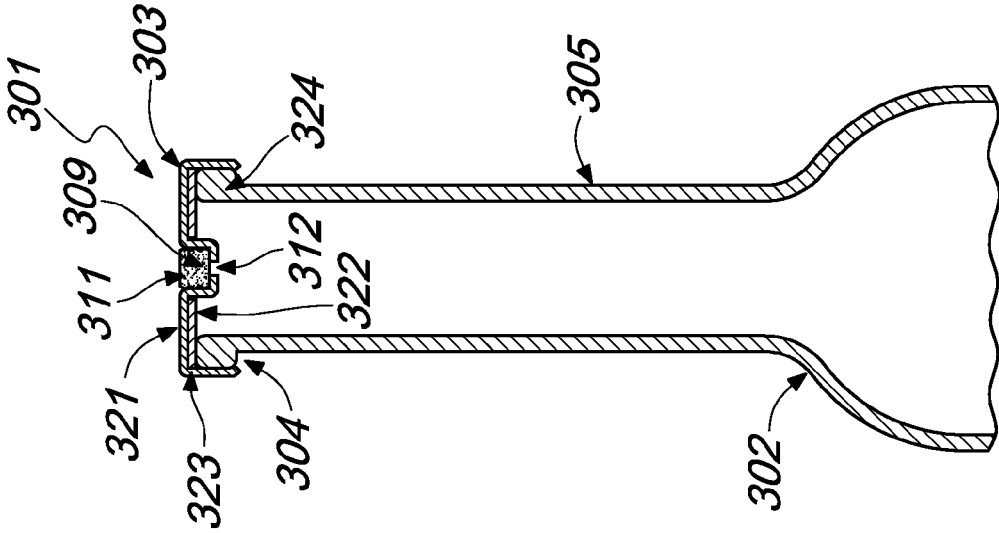

Fig. 8

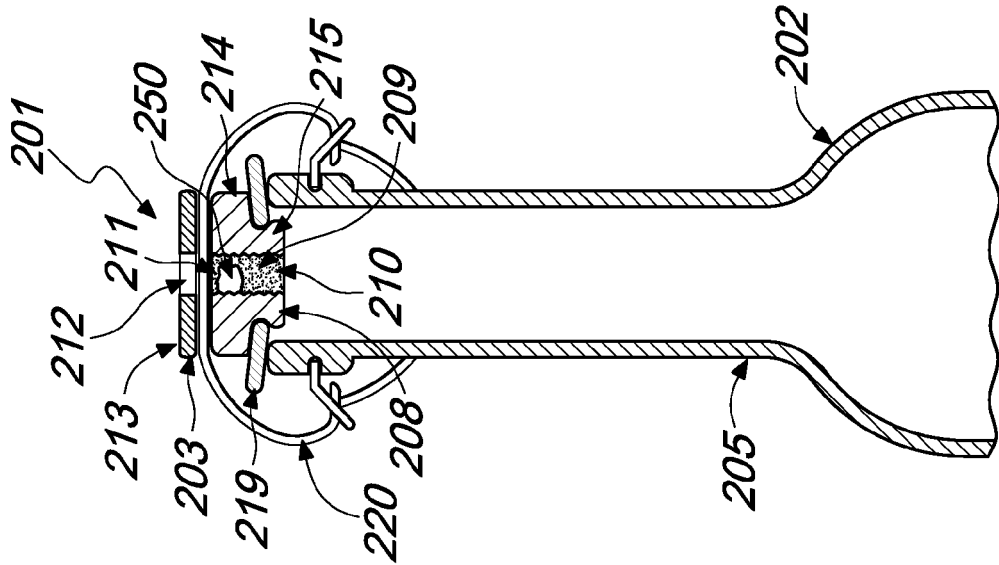
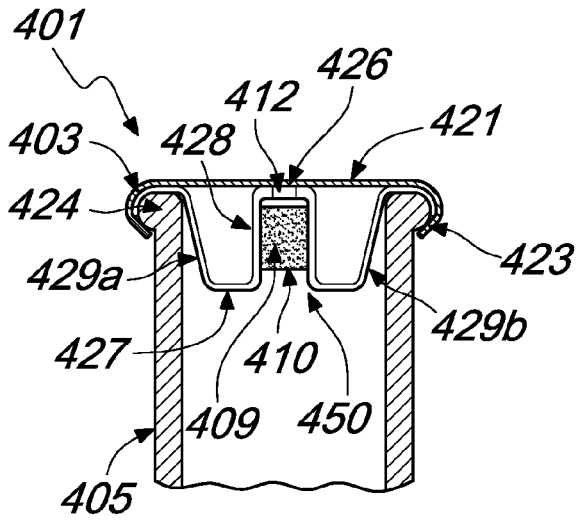
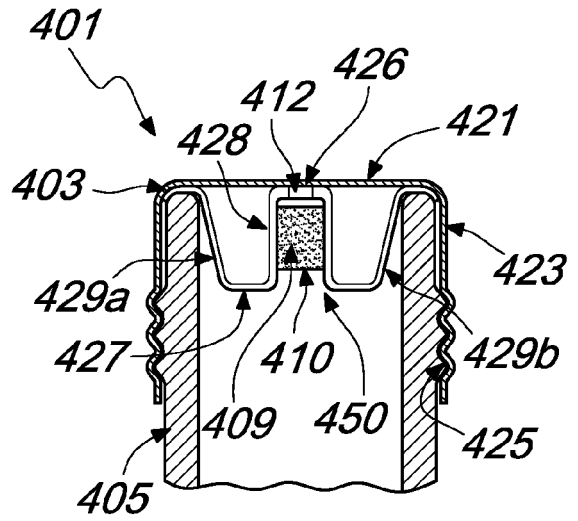

Fig. 7



*Fig. 10*



*Fig. 11*

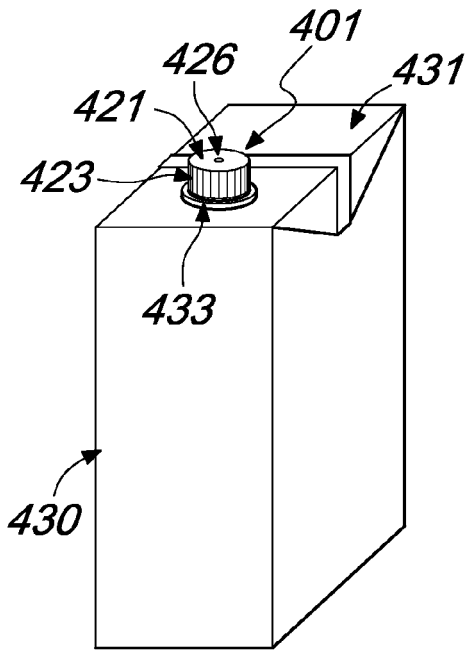

*Fig. 12*

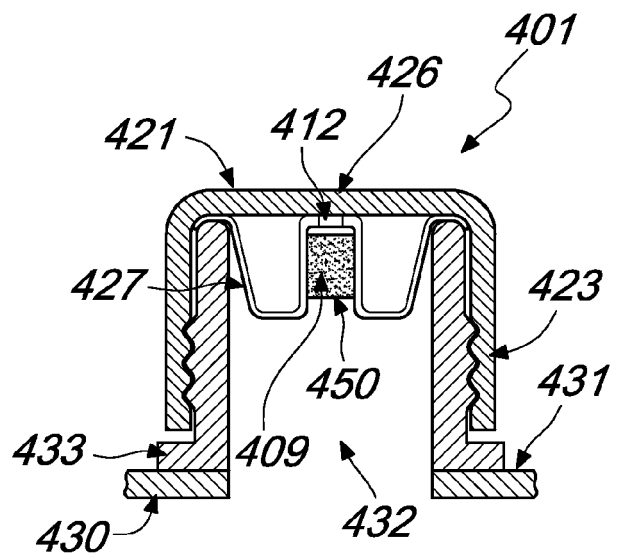

*Fig. 13*

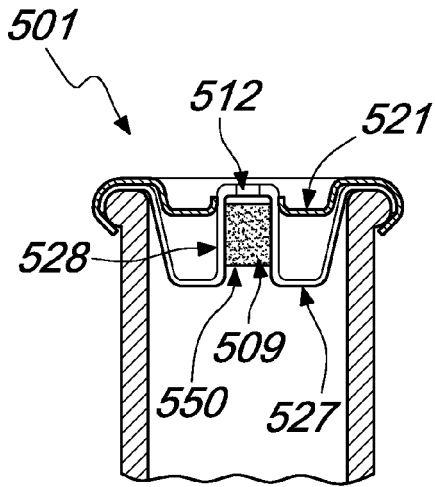

*Fig. 14*

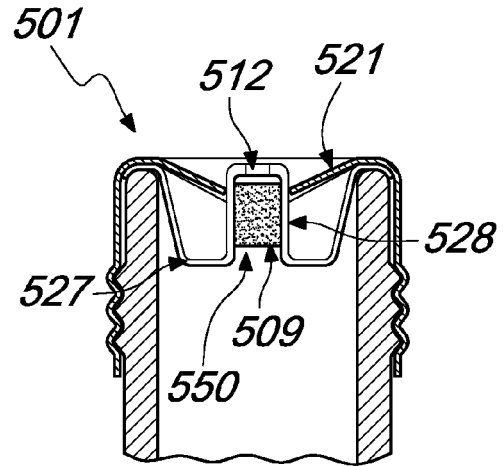

*Fig. 15*

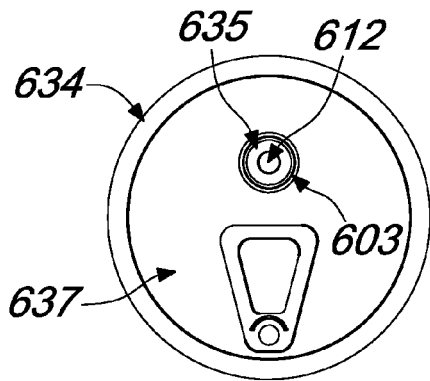

*Fig. 16*

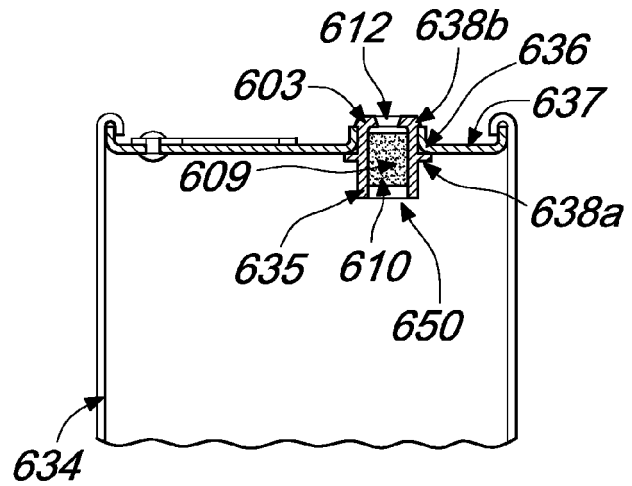

*Fig. 17*



DOCUMENTS CONSIDERED TO BE RELEVANT			
Category	Citation of document with indication, where appropriate, of relevant passages	Relevant to claim	CLASSIFICATION OF THE APPLICATION (IPC)
X	GB 654 541 A (JAMES RONALD CANTRILL) 20 June 1951 (1951-06-20)	1-5,9, 10,12	INV. B65D39/00
Y	* column 2; figures 1-3 * -----	6-8,11	B65D39/04
X	WO 02/055397 A (MUSARAGNO MARCO [IT]) 18 July 2002 (2002-07-18)	1,2	
Y	* page 3, line 26 - page 4, line 35; figures 1-6 * -----	7	
X	EP 0 629 559 A1 (NUSSBAUMER BENNO [CH]) 21 December 1994 (1994-12-21)	1	
Y	* figure 2 * -----	8	
Y	GB 797 812 A (HAROLD ERIC CHAPMAN; JAMES BENNETT MORTIMORE) 9 July 1958 (1958-07-09)	6,11	
	* page 3, line 1 - line 19 * -----		
A	DE 201 18 946 U1 (SCHEFFER GEORG [DE]) 21 February 2002 (2002-02-21)	3-5	
	* figure 1 * -----		
			TECHNICAL FIELDS SEARCHED (IPC)
			B65D
-The present search report has been drawn up for all claims			
Place of search Munich		Date of completion of the search 15 October 2007	Examiner Bevilacqua, Vincenzo
CATEGORY OF CITED DOCUMENTS		T : theory or principle underlying the invention E : earlier patent document, but published on, or after the filing date D : document cited in the application L : document cited for other reasons ..... & : member of the same patent family, corresponding document	
X : particularly relevant if taken alone Y : particularly relevant if combined with another document of the same category A : technological background O : non-written disclosure P : intermediate document			



European Patent  
Office

Application Number  
EP 07 10 7798

### CLAIMS INCURRING FEES

The present European patent application comprised at the time of filing more than ten claims.

- Only part of the claims have been paid within the prescribed time limit. The present European search report has been drawn up for the first ten claims and for those claims for which claims fees have been paid, namely claim(s):
- No claims fees have been paid within the prescribed time limit. The present European search report has been drawn up for the first ten claims.

### LACK OF UNITY OF INVENTION

The Search Division considers that the present European patent application does not comply with the requirements of unity of invention and relates to several inventions or groups of inventions, namely:

see sheet B

- All further search fees have been paid within the fixed time limit. The present European search report has been drawn up for all claims.
- As all searchable claims could be searched without effort justifying an additional fee, the Search Division did not invite payment of any additional fee.
- Only part of the further search fees have been paid within the fixed time limit. The present European search report has been drawn up for those parts of the European patent application which relate to the inventions in respect of which search fees have been paid, namely claims:
- None of the further search fees have been paid within the fixed time limit. The present European search report has been drawn up for those parts of the European patent application which relate to the invention first mentioned in the claims, namely claims:  
1-12
- The present supplementary European search report has been drawn up for those parts of the European patent application which relate to the invention first mentioned in the claims (Rule 164 (1) EPC).



The Search Division considers that the present European patent application does not comply with the requirements of unity of invention and relates to several inventions or groups of inventions, namely:

1. claims: 1-12

a stopper comprising a body which can be associated within the open end of the neck of a bottle so as to close it and a block associated axially and internally within said body and made of a material permeable to air impermeable to liquids and porous, its ends being connected, directly or by means of at least one duct to the inside and the outside of said bottle  
whereby

---

2. claims: 13-14,20-32

a stopper comprising a body constituted by a disk which can be positioned on the free end of the neck of a bottle so as to close it and a block associated axially and internally within said body and made of a material permeable to air impermeable to liquids and porous, its ends being connected, directly or by means of at least one duct to the inside and the outside of said bottle

---

3. claims: 15-19

a stopper comprising a body which can be associated within the open end of the neck of a bottle so as to close it and a block associated axially and internally within said body and made of a material permeable to air impermeable to liquids and porous, its ends being connected, directly or by means of at least one duct to the inside and the outside of said bottle  
whereby the block is obtained by sintering a particular material and is enriched with bactericidal substances

---

ANNEX TO THE EUROPEAN SEARCH REPORT  
ON EUROPEAN PATENT APPLICATION NO.

EP 07 10 7798

This annex lists the patent family members relating to the patent documents cited in the above-mentioned European search report.  
The members are as contained in the European Patent Office EDP file on  
The European Patent Office is in no way liable for these particulars which are merely given for the purpose of information.

15-10-2007

Patent document cited in search report		Publication date	Patent family member(s)	Publication date
GB 654541	A	20-06-1951	NONE	
-----				
WO 02055397	A	18-07-2002	AT 292061 T	15-04-2005
			BG 108602 A	28-02-2005
			BR 0117115 A	17-08-2004
			CA 2456413 A1	18-07-2002
			CN 1545468 A	10-11-2004
			DE 60109825 D1	04-05-2005
			DE 60109825 T2	19-01-2006
			EP 1423310 A1	02-06-2004
			ES 2240347 T3	16-10-2005
			HR 20040113 A2	28-02-2005
			HU 0401705 A2	28-12-2004
			IT VI20010180 A1	28-02-2003
			JP 2004526634 T	02-09-2004
			MD 20040040 A	31-08-2004
			MX PA04001766 A	31-05-2004
			NZ 531159 A	24-02-2006
			PL 366797 A1	07-02-2005
			PT 1423310 T	29-07-2005
			SK 1192004 A3	05-10-2004
			US 2004074862 A1	22-04-2004
			ZA 200401084 A	18-11-2004
-----				
EP 0629559	A1	21-12-1994	AT 142585 T	15-09-1996
			CH 687694 A5	31-01-1997
			DE 59400625 D1	17-10-1996
			ES 2091681 T3	01-11-1996
-----				
GB 797812	A	09-07-1958	DE 1813238 U	15-06-1960
			ES 237379 A1	16-02-1958
-----				
DE 20118946	U1	21-02-2002	DE 10243802 A1	28-05-2003
-----				

EPO FORM P0459

For more details about this annex : see Official Journal of the European Patent Office, No. 12/82

**REFERENCES CITED IN THE DESCRIPTION**

*This list of references cited by the applicant is for the reader's convenience only. It does not form part of the European patent document. Even though great care has been taken in compiling the references, errors or omissions cannot be excluded and the EPO disclaims all liability in this regard.*

**Patent documents cited in the description**

- WO 02055397 A [0017]