

S. M. FIREY.
SEEDING MACHINE.

No. 109,503.

Patented Nov. 22, 1870.

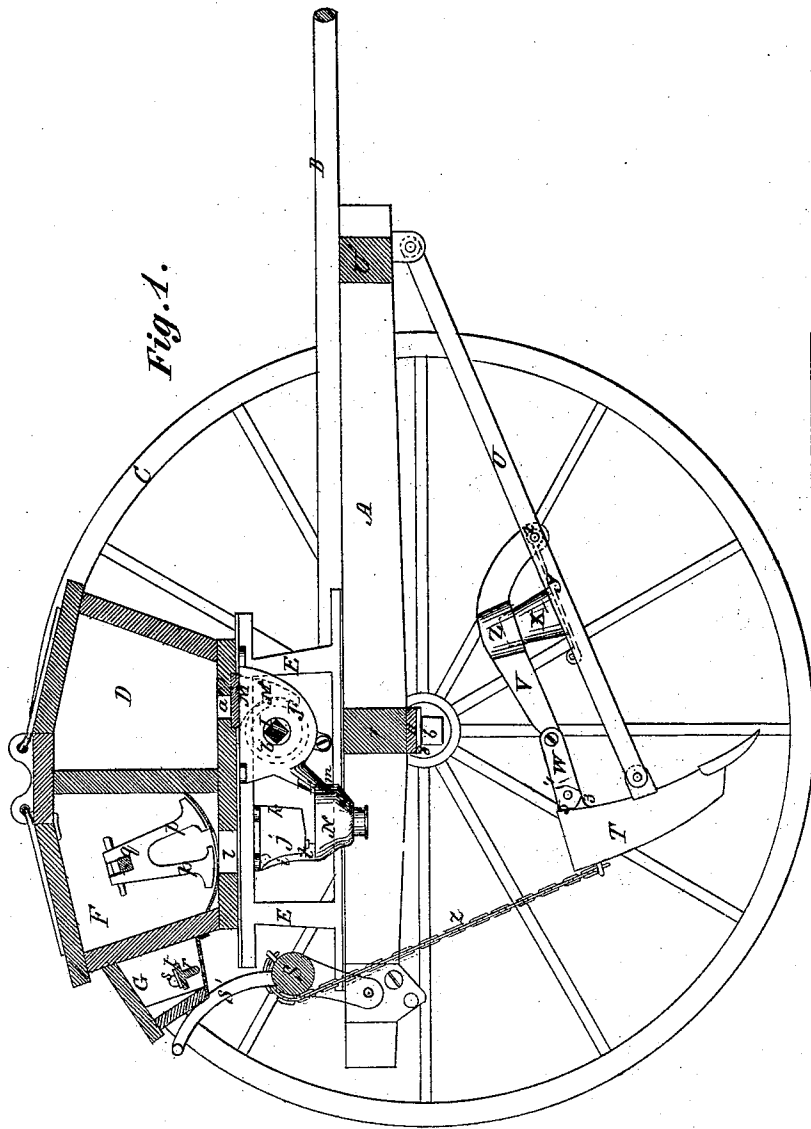

Witnesses,
J. W. Hamilton Johnson
Lewis B. Wynne, Jr.

Samuel M. Firey, Inventor
By his Attorneys,
Wofferman & Johnson.

S. M. FIREY.
SEEDING MACHINE.

No. 109,503.

Patented Nov. 22, 1870.

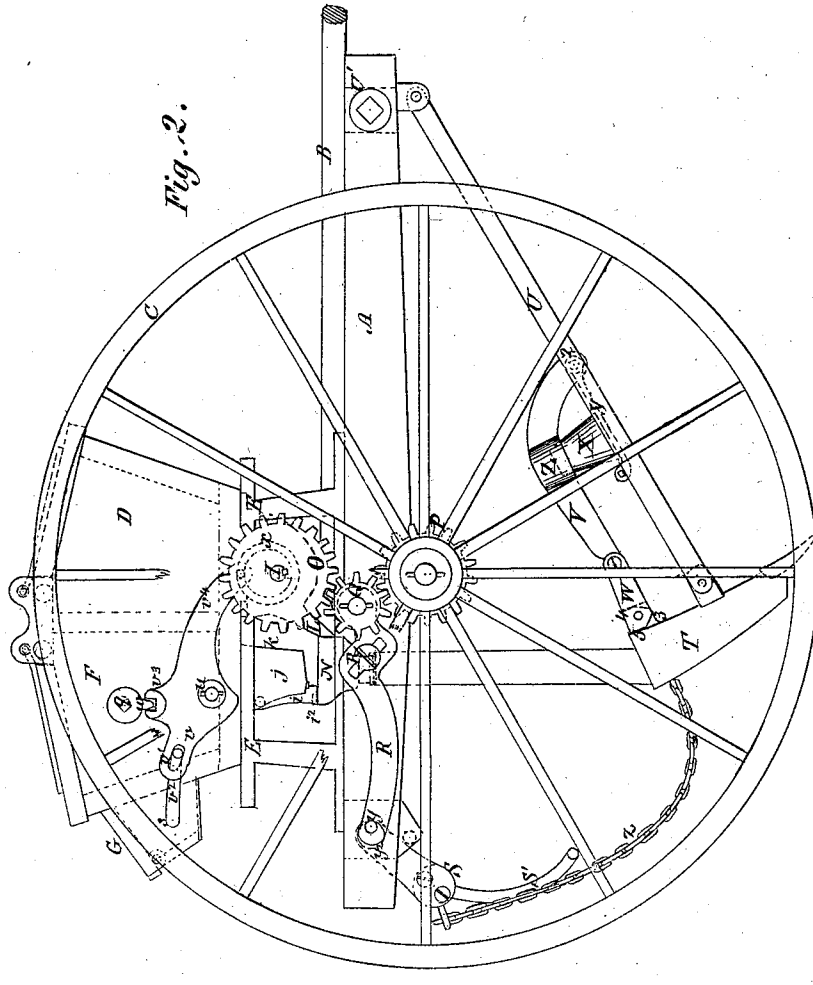

Witnesses
J. W. Hamilton Johnson
Lewis B. Wayne, Jr.

Samuel M. Fiery, Inventor.
By his Attorneys,
Wolferman & Johnson.

S. M. FIREY.
SEEDING MACHINE.

No. 109,503.

Patented Nov. 22, 1870.

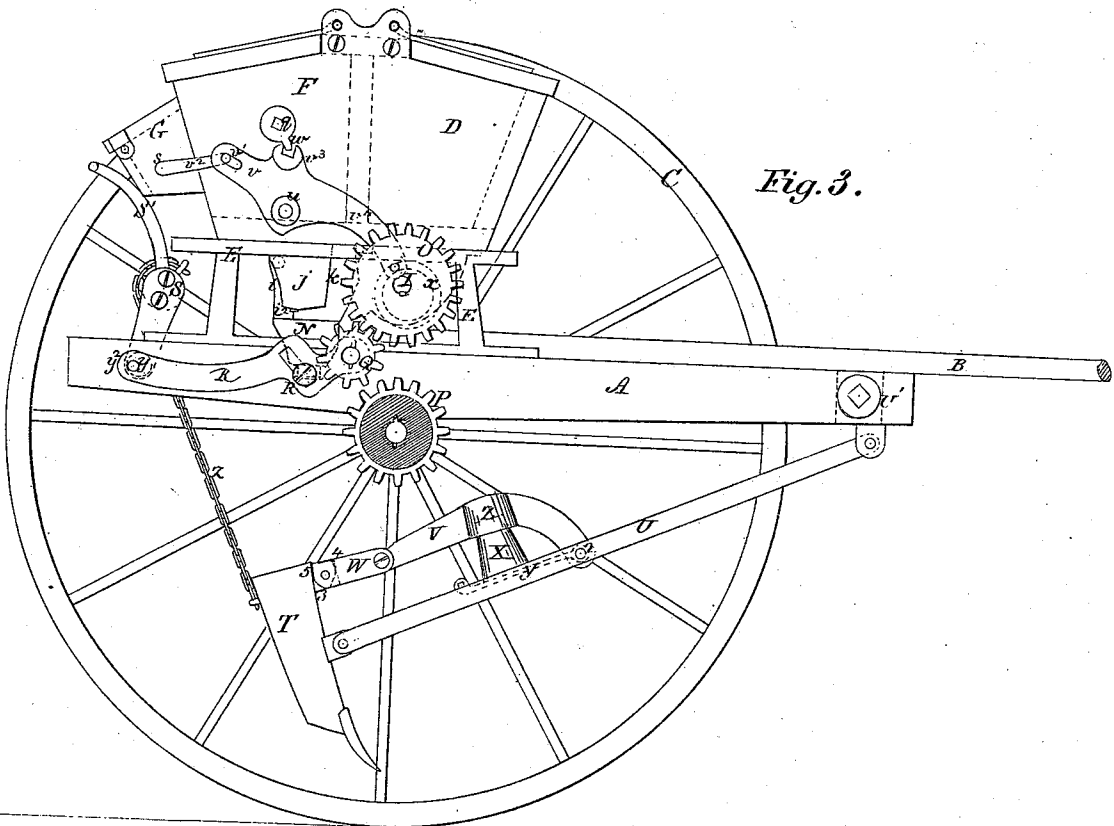

Fig. 3.

Witnesses

W. Hamilton Johnson
Lewis B. Wayne, Jr.

Samuel M. Firey, Inventor.
By his Attorneys,

Wofferman & Johnson

S. M. FIREY.
SEEDING MACHINE.

No. 109,503.

Patented Nov. 22, 1870.

Fig. 4.

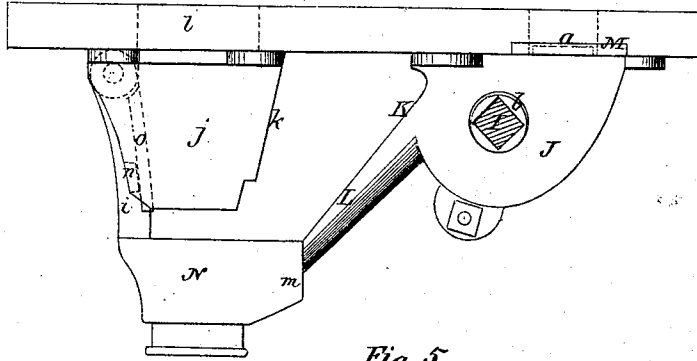

Fig. 5.

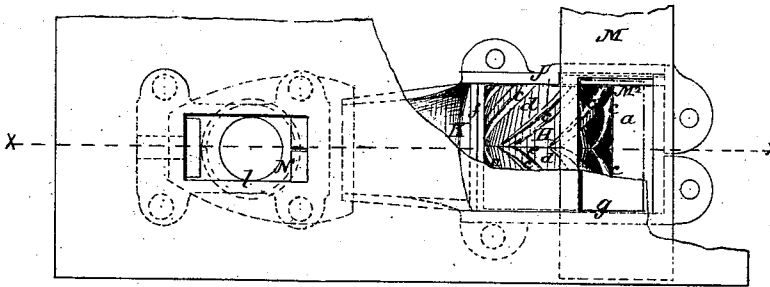

Fig. 6.

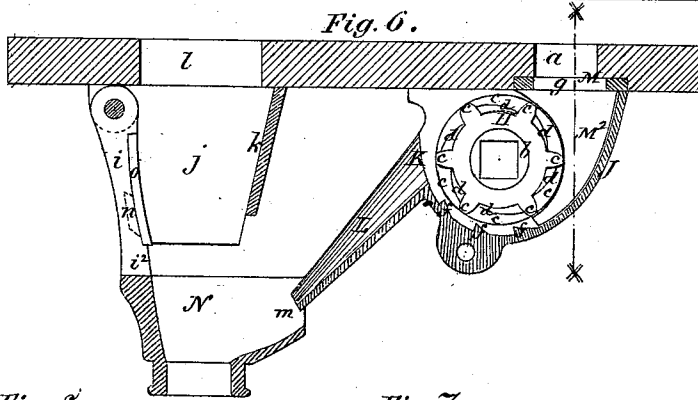

Fig. 8.

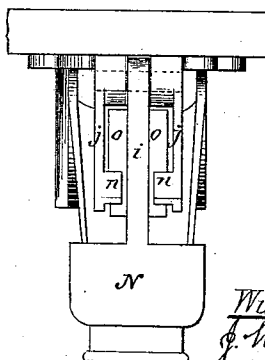
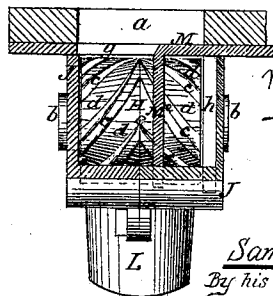

Fig. 7.



*Wheel revolves with depth
end of the channel forward*

*Samuel M. Firey, Inventor,
By his Attorneys,*

Woffherman & Johnson,

Witnesses

*J. W. Hamilton, Colonel
Lewis B. Wapner, Jr.*

S. M. FIREY.
SEEDING MACHINE.

No. 109,503.

Patented Nov. 22, 1870.

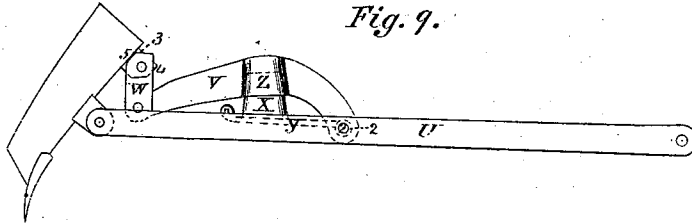

Fig. 9.

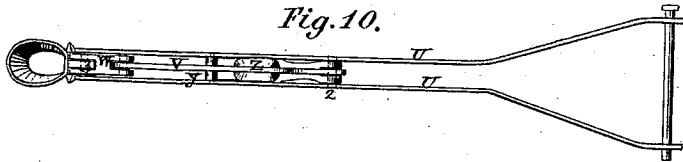

Fig. 10.

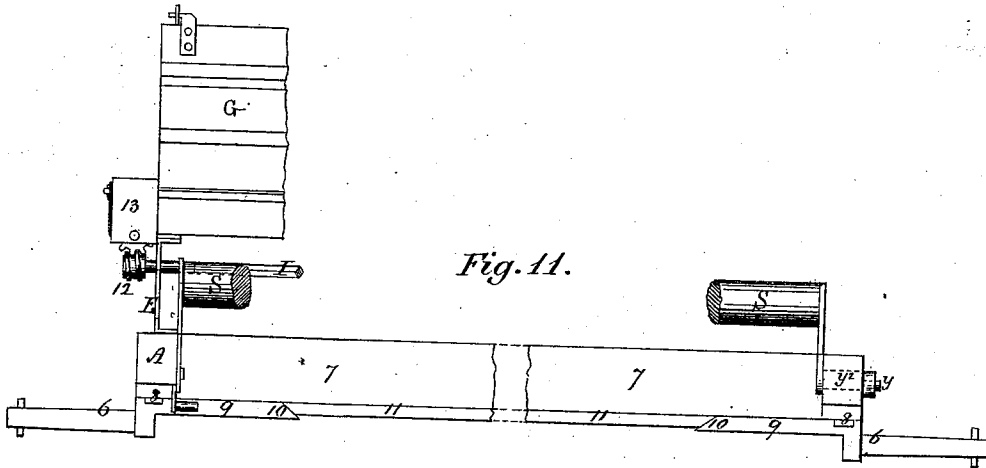

Fig. 11.

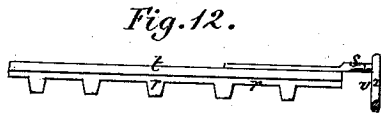

Fig. 12.

Witnesses.
A. W. Hamilton Johnson
Lewis B. Wynne, Jr.

Samuel M. Firey, Inventor.
By his Attorneys,
Wofferman & Johnson.

United States Patent Office.

SAMUEL M. FIREY, OF CLEAR SPRING, MARYLAND.

Letters Patent No. 109,503, dated November 22, 1870.

IMPROVEMENT IN SEEDING-MACHINES.

The Schedule referred to in these Letters Patent and making part of the same.

To all whom it may concern :

Be it known that I, SAMUEL M. FIREY, of Clear Spring, in the county of Washington and State of Maryland, have invented certain new and useful Improvements in Seeding-Machines; and I do hereby declare that the following is a full, clear, and exact description thereof, reference being had to the accompanying drawing of the same, which makes part of this specification, and in which—

Figure 1 represents a vertical section, taken through the line of draft of a machine embracing my improvements;

Figure 2 represents a side elevation of the gearing side of the machine, showing the drill-tubes down, and the seeding and fertilizing mechanism in gear with the driving-wheel;

Figure 3 represents a similar view, showing the drill-tubes elevated, and the seeding and fertilizing mechanism out of gear;

Figure 4 represents a side elevation of the yielding fertilizing conductor and seed-feeder;

Figure 5, a top view;

Figure 6, a vertical section at the line *x x* of fig. 5;

Figure 7, a vertical section of the cup, seed-feeder, and graduating winged slide at the line *X X* of fig. 6; and

Figure 8, a view of the rear side of the yielding fertilizing conductor, these several figures being on an enlarged scale.

Figure 9 represents one of the drag-bars and its drill-tooth, showing the latter when turned back to pass an obstruction.

Figure 10 represents a top view of these parts when the drill-tube is not turned back.

Figure 11 represents the axle-tree, with its short bent axles and bracing-board.

Figure 12 represents a portion of the timothy-stirrer, showing also the attachment of the surveyor to the seeding-shaft.

In the accompanying drawing the frame *A*, tongue *B*, and supporting wheels *C* may be constructed and arranged in any suitable manner.

The seeding-hopper *D* is mounted at each end upon metallic supports *E*, secured to the side timbers of the frame, so as to be directly over the axle of the wheels; and the fertilizing and timothy-hoppers *F* and *G* are secured to and arranged in the rear of the seeding-hopper.

The seed-feeders *H* are arranged upon a shaft, *I*, beneath the seeding-hopper *D*, and are inclosed in separate and independent cases or cups *J*, secured to the bottom of the hopper, there being one such seed-feeder to each drill-tube or tooth; and they are supplied from the hopper, through openings *a*, in the usual manner.

The cups or cases *J* are cast in two parts and bolted together, and to the bottom of the hopper; they are of semicircular form, and have a concave discharging-mouth or opening, *K*, at their rear side, from which a spout, *L*, extends into the mouth of a yielding fan or conducting-tube.

Each seed-feeder *H* is provided with bearing hubs *b*, at either end, which fit into corresponding openings in the sides of the cup, so that the ends of the feeder revolve against the inner sides of said cup, as shown in figs. 5 and 7. They are cast in the form of two frustums or cones, united at their base, having upon their circumference, at suitable distances, ribs *c*, arranged in the form of the letter *V*, and extending from the base of each frustum of a cone to the ends thereof, so as to form a skeleton cylinder with the channels *d*, gradually increasing in depth from the base line *e* of the cones to their ends, as shown in figs. 5, 6, and 7, and thereby dividing the feeder into two separate series of feeding-channels, either or any portion of which may be used at pleasure, so as to hold quite a body of seed, but deliver it in a thin and even stream.

The feeders are revolved with the deepest ends of their channels foremost in such proximity to the sides of their inclosing cups as to receive and lift the grain, by the ribs *c*, like a screw-thread, drawing it from the ends to the middle of the feeder and discharging it into the concave spout *L*.

A space is left between the bottom of the cup and the ribs of the feeder which increases to the discharging-mouth *K*, in order that the grain will not be mashed and bruised between the unyielding surfaces.

To hold it as it is raised in this space, and prevent it from falling back, a series of ribs, *f*, parallel to the axis, are cast on the inside of the cup from the bottom to near the mouth, inclined on one side to allow the grain to pass readily over them, and constitute a series of steps to hold the grain as it is raised from the bottom by the feeder, and insure its regular feed, whether going up or down hill, as shown in fig. 6.

The openings *a* in the hopper are lengthwise thereof, and equal to the width of the cups; and the regulating-slide *M* is fitted in a recess on the under side of the hopper with openings *g*, corresponding to those in the hopper, and may be adjusted to diminish the area of the supply openings *a*, according to the soil and the quality of the seed to be sown.

A graduating wing, *M*², depends from the slide into the cup in front of the feeder *H*, so as to conform both to the curve of the latter and the inclosing cup, and terminate in a point nearly beneath said feeder, so as to cut off and expose more or less of the channeled surface of the feeder, and thus regulate its capacity to the supply of grain.

When the slide M is entirely open, the graduating wing M² occupies a space or recess, h, cast in the side of the cup or case, so as to be flush with the inside thereof, as shown in figs. 5 and 7 of the drawing.

This arrangement of the graduating wing allows the feeder to be used in part without spreading the seed within the entire cup, but confines it to so much of the channeled surface as is exposed to the supply opening.

The seed-feeders are made with angular openings, and the shaft I, upon which they are fitted, has a corresponding form, so that they must turn simultaneously, while the adjustment of the slide controls alike the adjustment of the wing of each seed-feeder.

The pan or conductor N is hinged by a vertical stem, i, between two plates j, closed at their front sides k, and open at their rear to receive the stem, said plates j being secured to the under side of the hopper, so as to inclose the openings l therein, through which the fertilizer descends, and allow the pan or conductor to swing forward from a vertical line to accommodate itself to the rising and forward movement of the drill-tubes, when thrown forward and upward to pass any obstruction, and thus protect the rubber tubes which lead from the conductor-pans into the drill-teeth from being creased or injured.

The concave spout L of the seed-feeder fits into the pan or mouth m of the conductor, with sufficient room to allow the latter to swing forward, while it is prevented from swinging back of a vertical line and separating such connection by two ears n, on the inclosing plates, against which the back o, hinged stem i rests, and closes the rear opening between the plates j, and as the mouth or pan N projects from the front side of the stem, it will act as a weight, and constantly tend to keep the conductor in a vertical line.

The pan is suspended so as to leave a space between its top and the bottom of the plates, and the stem is made narrow at its connection with the pan so as to afford facility for seeing the flow of the seed and fertilizer, as shown in figs. 4, 6, and 8.

The openings l in the fertilizing hopper are made lengthwise across its bottom, which, in connection with the divided arms p, arranged upon their shaft q, so as to vibrate back and forth over these openings l, in the direction of their length, not only tends to keep the latter free from being clogged, but enables me to maintain a uniform opening between the feeding-arms, and thereby insure a more regular feed of the fertilizer, with less range of motion of the arms.

The timothy-hopper G has a perforated bottom, and is located in rear of the fertilizing-hopper to sow timothy-seed between the drill furrows.

The timothy-stirrer consists of a horizontal bar, r, secured by pivots s projecting from its upper side, so as to oscillate eccentrically in the body of the seed, as shown in fig. 12. It is T-shaped in its cross-section, and the edge of the vertical part r may be either toothed or regular; and oscillates with a slow eccentric movement, moving the grain horizontally, while while the flat cap t moves it vertically, and acts as a strengthening-bar to the stirrer, as shown in figs. 1 and 12.

The mechanism for operating the fertilizing and timothy-stirrers consists of a tri-branched lever pivoted at u, near the middle of its length, to the end of the hopper, one branch, v, of which is locked by means of a slot, v¹, to a crank, v², on the pivot s of the stirrer, and a contiguous branch, v³, is locked by a notch to a tooth, w, on the end of the bar q, which carries the fertilizing-stirrers p, while the opposite end or branch v⁴ fits and is held in an eccentric groove, x, in the inner face of the cog-wheel O on the end of the shaft of the seed-feeders, so that each revolution of said wheel will vibrate the lever, and with it communicates a slow backward and forward motion to the stirrers. This movement and that of the seed-feeders is derived from a cog-

wheel, P, on the hub of the driving-wheel, which engages by an intermediate pinion, Q, with the first-named wheel.

To disengage and stop the motion of the seed-feeders and stirrers when required, the intermediate pinion Q is mounted upon the end of an arm, R, secured to the side of the frame by a bolt passing through an inclined slot, R', in said arm, while its other end is connected to a pin, y, secured eccentrically to the axis y² of the lifting-bar S, so as to be within the circumference of said axis, as shown in figs. 2, 3, and 11; and in turning the lifting-lever S' to raise the tubes T, the arm R, and the pinion Q, which it carries, will be drawn backward and upward from gear with the driving-wheel, as shown in fig. 3, but remain in gear with the cog-wheel O, and when the drill-tubes are down, the eccentric-pin y will force said arm R and pinion Q inward and put the parts in gear, as shown in fig. 2.

In casting the pin y within the circumference of the bearing y² of the lifting-bar S, the bearing-holes are not required to be larger than said bearings y², and it is a saving in expense to so form the eccentric-pin y on the bearing, as shown in fig. 11.

To hold the bar S up when elevated with the drill-tubes, it is arranged so as to lean forward and rest against the back of the hopper or projections on the frame, so that the weight of the teeth will draw the supporting chain z in advance of the axis of said lifting-bar S, and thus hold it up by its position and the weight of the teeth without other fastening, as shown in fig. 3.

The drag-bars U are hinged to the front beam U', and connected by chains z to the lifting-bar S in the usual manner. They are formed of two bars hinged to the drill-tube and united together near the middle of their length. At this point the end of a goose-necked check-lever V is secured between the bars by a strong bolt, 2, so as to turn thereon, and extending rearward is hinged to a check-link, W, which is also hinged to a check-ear or lug, 3, cast on the upper end of the tube T above the hinge of the drag-bar, the ends of the ear 3 and the link W having a double check, the former acting against the link and the latter against the tube, as shown at 4 and 5, fig. 9.

A gum-spring, X, having the form of a flattened frustum is interposed between this check-lever V and a seat Y, hinged between the drag-bars by one end to the bolt 2, which secures the check-lever V and rests by the other upon said bars.

The hinged end of this spring-seat embraces the front hinged end of the check-lever, and thus serves to brace it laterally with the spring, which is held in place by a socket, Z, cast with the check-lever V, into which it fits, and held at its lower end upon its seat Y between the drag-bars, for which purpose its sides are flattened.

The seat Y will be held constantly upon the drag-bars by the force of the spring.

The rear end of the check-lever V maintains a slight angle with the check-link W, and the latter is held in proper position by the checks above described, and thus holds the link W in the proper position to flex the joint of the check-lever V whenever the drill-tube comes in contact with an obstruction, which offers undue resistance.

The supporting-wheels are mounted upon short axles 6, secured to the under side of a cross-timber, or axle-tree 7 of the frame, and to the side timbers thereof by screw-bolts.

The short axles have also cast with them bracing plates or supports 8, which fit against the under side of the side beams A, and hold the axles firmly against all tendency to twist from their bolts.

The tree-plates 9 of the axles are bent above a right line with the bearing 6 thereof, which give the advantage of using smaller driving-wheels, and the ends of these tree-plates form gripping-points or seats

10 between and to which the bracing-bar 11, which supports the axle-tree 7, is locked and braced, thus rendering the frame, axle-tree, and short axles firmer and more durable, and preventing the axle-tree from sagging, as shown in fig. 11.

On the left end of the feeder-shaft a worm, 12, is placed for the purpose of operating a surveyor, 13, to determine the quantity of grain sown per acre; the location of the surveyor at the end of the hopper affords greater facility for its attachment, as well as for examining the face of the indicator and ascertaining the acreage sown. It may be of any suitable construction for measuring and indicating the land sown, and secured to the end of the hopper, so that its mechanism will be operated by the worm, as shown in fig. 11.

Having described my invention,

I claim—

1. A cylindrical seed-feeder, with cavities or channel: *d*, in combination with the inclosing case or cup J and the fingered or winged slide *M*², for the purpose of regulating the quantities of grain to be sown, substantially as herein described.

2. The cups or inclosing cases J of the seed-feeders H, constructed with stops or steps *f* near their discharging-mouth K, for the purpose and in the manner herein shown and described.

3. In combination with a seed-feeder, constructed with ribs *c* and channels *d*, the inclosing case or cup J, made with stops or steps *f* near its discharging-mouth, as herein described.

4. The pan N, hinged by its stem *i*, so that the latter forms the back of the conductor, in combination with the stops *n*, to limit the rearward movement of said pan, as described.

5. The check-lever V and the seat Y of the spring, hinged together between double drag-bars, as and for the purpose described.

6. As an improvement on my former patent, the eccentric groove in the wheel O, in combination with the tri-branched pivoted slotted lever *v*, for operating both the fertilizer and grass-seed stirrers, with a slow and uniform motion, as described.

7. the brace 11, when locked with the short axles 9, for the purpose and in the manner herein shown and described.

In testimony whereof, I have hereunto signed my name.

SAMUEL M. FIREY.

Witnesses:

F. H. UPPERMAN,
A. E. H. JOHNSON.