

Oct. 11, 1938.

W. M. WEBSTER

2,133,003

COMBINATION STEP AND EXTENSION LADDER

Filed Jan. 12, 1937

Fig. 1.

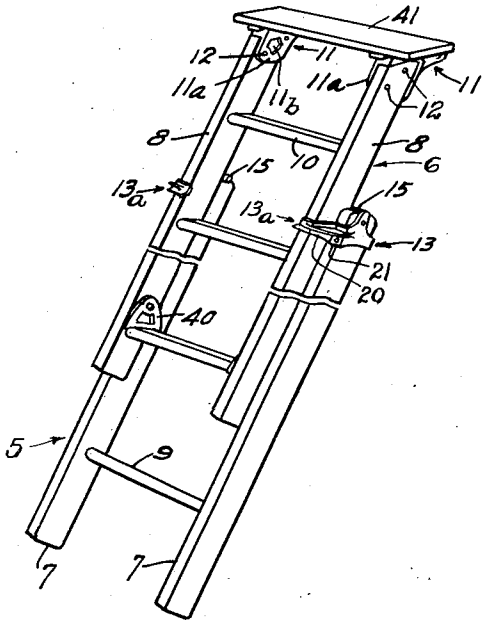

Fig. 4.

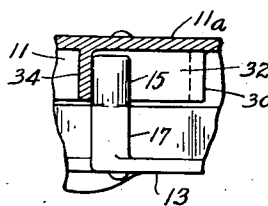

Fig. 2.

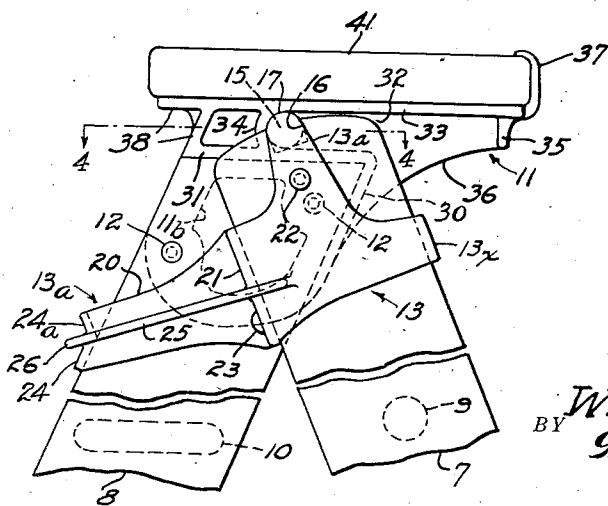
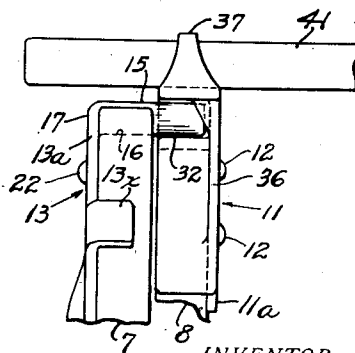

Fig. 3.



INVENTOR
Willard M. Webster
BY Robt. W. Pearson
ATTORNEY

UNITED STATES PATENT OFFICE

2,133,003

COMBINATION STEP AND EXTENSION LADDER

Willard M. Webster, Los Angeles, Calif.

Application January 12, 1937, Serial No. 120,238

3 Claims. (Cl. 228—25)

This invention relates to a combination step and extension ladder construction furnished with the usual side rails and treads or steps between them and having cooperating attachments carried by the upper end portions of the rails of the ladder to limit the outward swinging movements of the foot portions of the ladder with relation to each other. The invention pertains more particularly to the novel attachments when considered either as a new article of manufacture or in combination with the remaining portions of the ladder structure.

One object of the invention is to provide attachments for the aforesaid purpose which insure greater safety to the user of the ladder and which contain in themselves a sufficient number of parts, both to hold the two sections of the ladder together and to limit the outward swing of the foot portions thereof.

Another object of the invention is to furnish an improved casting of a simplified, more sturdy character to replace attachments now on the market for the purpose of holding together the sections of a ladder and limiting the swing as aforesaid with relation to each other.

Other objects, advantages and features of the invention may hereinafter appear.

Referring to the accompanying drawing which illustrates what is at present deemed to be a preferred embodiment of the invention,

Fig. 1 is a perspective view of the two ladder sections when set up for an extension ladder, parts being broken away.

Fig. 2 is a side elevational view of the two ladder sections when set up for a step ladder, parts being broken away.

Fig. 3 is a rear elevational view of Fig. 2.

Fig. 4 is a fragmental sectional view taken on line 4—4 of Fig. 2.

Referring in detail to the drawing, the ladder sections 5 and 6 are formed by the side rails 7 and 8 respectively, the steps 9 and 10 being secured between said rails. Each rail 8 is furnished with a socketed or recessed casting 11 which is secured to the upper end portion of each rail 8 by rivets 12 or in some other suitable manner, and each of the other rails 7 is attached to its upper end portion a male casting member 13 which cooperates with the first recited members both to keep the two ladder sections in an attached relation to each other and to limit properly the outward swing of their foot portions.

The socketed attachments 11 are furnished with attaching plates 11a which overlie the inner sides of the side rails 8. Said plates 11a,

by preference and as shown, are of a rim-like arcuate character enclosing a considerable open area 11b. Each male member 13 is furnished with an attaching arm or plate 13a which is secured to the outer side of the rail 7 at its side of the ladder.

Describing first the detailed construction of the male member 13, its attaching arm 13a is furnished at its upper end with a laterally extending stop arm 15 the base portion of which, 10 preferably amounting to about half its length, fits within a groove 16 being desirably made approximately rectangular in cross-section within said groove. Said stop arm is furnished with a circular end portion 17 which cooperates with the socketed member, as will hereinafter be described. Said male member 13 further is furnished with a bracket or extension 20 having an angularly directed base portion 21 which seats upon the adjacent edge portion of the rail to which the male member is attached, and which is integral with the arm 13a already described.

The bracket 13a has a right angular extension 13x which overlies the outer edge of the rail 7 thus stabilizing the male member 13 in its relation to the ladder.

An attaching rivet 22 is shown extending through the arm 13a and an attaching rivet 23 is shown extending through the base portion 21 of the extension 20. The outer end of said extension 20 is furnished with an angular flange 24 which projects oppositely to the base portion 21 of the extension. When the ladder is in an upstanding position with its foot portions separated as far as possible said flange 24 abuts against the adjacent edge portion of the rail 8 to arrest farther separation of the foot portions of the ladder. The extensions or flanges 24 and 13x at opposite ends of the male member cooperate to secure this result. The male member 13 is shown furnished at about its mid-width with an angularly disposed reinforcing flange 25 which extends along a portion of the inner part of the arm 13a and thence up over the extension 20 across the outer side of the angular flange 24. The part 26 of said reinforcing flange which overlies the outer side of the angular flange 24 is shown engaging the inner angle of said flange 24 and tapering to a point as it approaches the outer edge of said flange 24.

Referring to another detail of construction. The angular stop flange 24 of the male member has an upper flange portion 24a which glides smoothly over the adjacent edge portion of the rail 8 against which this part of the flange abuts

when the ladder is being extended or retracted as an extension ladder. Hence the two flange portions of the part 24 abut in a flatwise manner with the edge of the rail either as a stop means or for reducing sliding friction.

Each socketed member 11 has at its inner side an attaching flange 30 which overlies the edge portion of the rail 8 and said socketed member has also an inwardly extending flange 31, the latter flange extending across the top surface of the rail to which said member is attached. These flanges 30 and 31 are both straight and join each other at an acute angle as shown. Above the flange 31 the socketed member is furnished with a top flange 33 in parallel spaced relation to the flange 31 thereby forming a groove 32 the width of which is somewhat greater than the diameter of the stop arm 15 of the male member. Said groove is open at one end and at its opposite end is furnished with a stop wall 34 to limit the sliding movement of the stop arm 15 of the male member which travels along said groove. When the foot portions of the ladder are swung as far apart as possible, said stop arm will engage said stop wall simultaneously with the engagement of the flange 24 of the male member with the edge portion of the rail of the ladder with which it cooperates, thus affording a stable and dependable limited movement of the foot portions of the ladder with relation to each other. It is to be understood that the arrangement of the cooperating rail and socketed members which have been described will be duplicated at opposite sides of the top portion of the ladder.

The socketed member 11 is shown having its flange 33 furnished with a triangular reinforcing flange 35 which cooperates with a flange extension 36 at that side of the top of the ladder. At this end said top flange is preferably furnished with an upstanding portion 37, which protects the ladder from wear when resting against a wall. A reinforcing flange 38 is shown below the top flange 33 at the opposite end thereof which is provided with an overhanging portion. In the completed ladder it is possible to swing the stop arms of the male members out of the ends of the grooves of the socketed members with which they cooperate and thereby permit the extension of the ladder as shown in Fig. 1. It is impossible to separate the two ladder sections from each other except in an endwise manner. 40 designates a pivoted stop member whereby the upper section of the ladder when used as an extension ladder is prevented from sliding downwardly over the other section while the ladder is in use. A construction is thus provided which will not allow the structure to function as a step ladder until the stop arm 15 comes to the proper position to slide into the socketed member. The foot portions of the ladder cannot be swung apart when the ladder is in any degree extended because the stop arm 15 and guide extension 13a of each male member travel upon the track afforded by the rail between them and the rungs 9 also afford an auxiliary guide means and support for the rails 8 when the ladder is used as an extension ladder.

The top flange 33 of the socketed or female member is shaped with a flat upper face to support a platform 41 against one side edge of which the upstanding flange 37 of said member abuts.

I claim:

1. The combination, with the side rails and step portions of a conventional step ladder; of connecting and controlling members for said ladder arranged in two sets at each side of the top portion of the ladder, each set of members thus provided consisting of a socketed member having with an open end groove, and a male member having a stop arm slidable within said groove and movable out of the open end thereof to permit of the extension of the ladder, said groove having a stop to arrest the movement of said stop arm therein, and the male member which has such stop arm having also an extension positioned to engage the outer side of the rail of the ladder which carries said socketed member at the time when said stop arm engages said stop, said male member being secured to the upper portion of a rail which is adjacent to the rail to which said socketed member is secured, the ladder rail to which said male member is secured having in its end portion a recess within which a portion of said stop arm is seated.

2. The combination with the side rails and step portions of a conventional step ladder; of connecting and controlling members for said ladder arranged in two sets at each side of the top portion of the ladder, each set of members thus provided consisting of a male member and a female member, the male members being movable into engagement with the female members when the ladder is to be used as a step ladder, and being disengageable from each other to permit of the extension of the ladder, the rail to which the male member is secured at each side of the ladder having in its end portion a recess, and such male member having an arm seated in said recess, said arm having a stop portion outside of said recess which aids in limiting the outward swing of the ladder sections when in use as a step ladder.

3. In a ladder construction of the kind described, a pair of similar socketed members mounted upon the upper extremities of rails at opposite sides of the ladder, said members each having parallel vertically spaced flanges which are inclined similarly and to such an angle as to cause them to occupy substantially a horizontal plane when the ladder sections are spread apart in the step ladder position, each of said lower flanges overlying the upper end of a ladder rail from edge to edge of such rail and each of said upper flanges having a portion at each end which projects beyond the adjacent edge of the rail, said upper flanges each having a flat face extending throughout its length, a platform supported upon said flat faces, the sockets of said members being formed by spaces between said parallel flanges each of which opens out at one end, the remainder of the space between said parallel flanges having a cross wall at its inner and its outer end, and male members attached to the ladder in positions to cooperate with said socketed members to control the extensibility of the ladder and the swinging movements thereof, said male members having arms which are engageable with the open end portions of said slots to an extent limited by engagement with the cross walls at the inner ends of aforesaid enclosed slotted portions.

WILLARD M. WEBSTER.