



US00D704558S

(12) **United States Design Patent**  
**Weiss**

(10) **Patent No.:** **US D704,558 S**

(45) **Date of Patent:** **\*\* \*May 13, 2014**

(54) **BEVERAGE BOTTLE**

(71) Applicant: **Bai Brands, LLC**, Princeton, NJ (US)

(72) Inventor: **Ben Weiss**, Princeton, NJ (US)

(73) Assignee: **Bai Brands, LLC**, Princeton, NJ (US)

(\*) Notice: This patent is subject to a terminal disclaimer.

(\*\*) Term: **14 Years**

(21) Appl. No.: **29/462,314**

(22) Filed: **Aug. 1, 2013**

(51) **LOC (10) Cl.** ..... **09-01**

(52) **U.S. Cl.**  
USPC ..... **D9/500**

(58) **Field of Classification Search**  
USPC ..... D9/500, 502-505, 516, 537, 539-540,  
D9/545, 549, 558, 682, 685-686, 688-692,  
D9/763, 772-773, 547, 764, 418;  
D24/224; 215/379, 382; 220/660,  
220/669-673, 675  
See application file for complete search history.

(56) **References Cited**

**U.S. PATENT DOCUMENTS**

D70,792 S	8/1926	Guerin	
D111,241 S *	9/1938	D'Addario	D9/500
3,460,702 A	8/1969	Andrews	
D276,889 S	12/1984	Biesecker	
D287,335 S *	12/1986	Anderson	D9/726
D424,447 S *	5/2000	Knobel	D9/528
6,083,450 A *	7/2000	Safian	264/515
D452,442 S	12/2001	Bowen	
6,499,329 B1	12/2002	Enoki et al.	
D491,809 S	6/2004	Silvers et al.	
D533,185 S *	12/2006	Ishida et al.	D14/203.2

D586,472 S	2/2009	Harold et al.	
D620,756 S *	8/2010	Lown et al.	D7/510
D621,220 S *	8/2010	Lown et al.	D7/510
D624,417 S	9/2010	Bentley et al.	
D624,821 S	10/2010	Leonardis	
D675,098 S	1/2013	Gonzalez Rodriguez	
D678,068 S	3/2013	Huang	
D682,697 S	5/2013	Gonzalez Rodriguez	
D695,619 S *	12/2013	Hoeko et al.	D9/521
D697,407 S *	1/2014	Hines	D9/500
2007/0158352 A1	7/2007	Cheng	

\* cited by examiner

*Primary Examiner* — Ian Simmons

*Assistant Examiner* — Dana L Meyrow

(74) *Attorney, Agent, or Firm* — Knobbe Martens Olson & Bear, LLP

(57) **CLAIM**

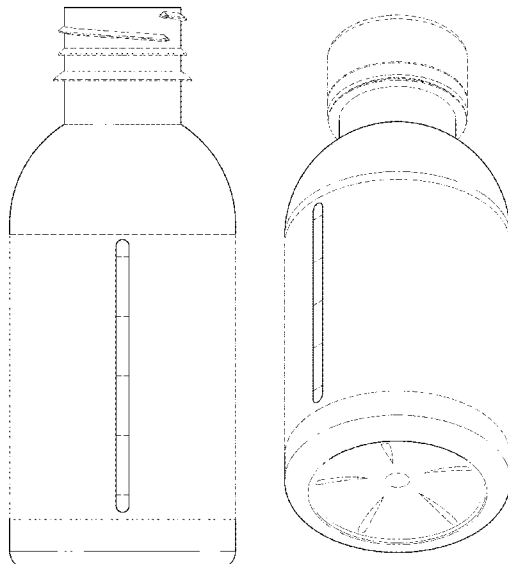
The ornamental design for a beverage bottle, as shown and described.

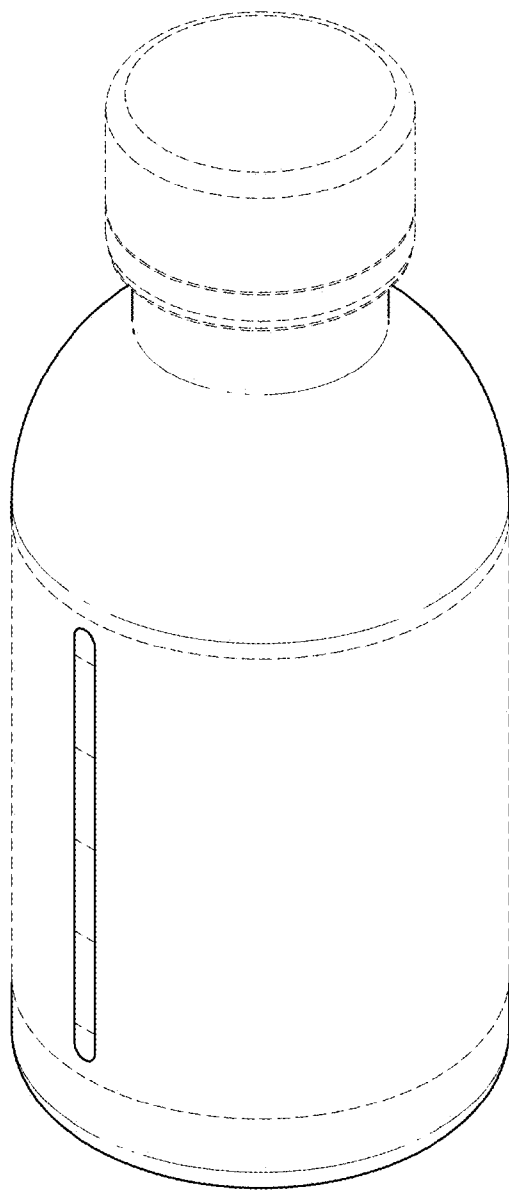
**DESCRIPTION**

FIG. 1 is a top perspective view of a beverage bottle showing our new design, with an unclaimed cap on the bottle; FIG. 2 is a front elevation view thereof; FIG. 3 is a top perspective view of the beverage bottle of FIG. 1, shown with the unclaimed cap removed; FIG. 4 is a front elevation view thereof; FIG. 5 is a rear elevation view thereof; FIG. 6 is a top plan view thereof; and, FIG. 7 is a bottom plan view thereof.

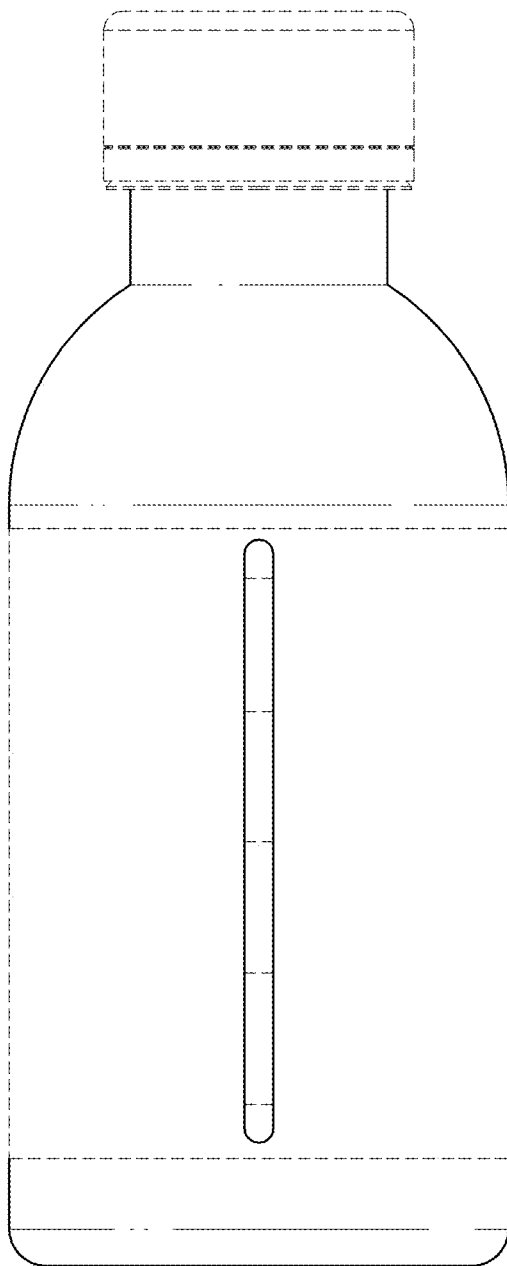
The broken lines in the drawings illustrate the portions of the design that form no part of the claim. The five horizontal broken lines that appear within the claimed elongated, oval-shaped sidewall detail in FIGS. 1-4 & 8 are unclaimed lines applied to the claimed surface. Those lines also form no part of the claim.

**1 Claim, 7 Drawing Sheets**

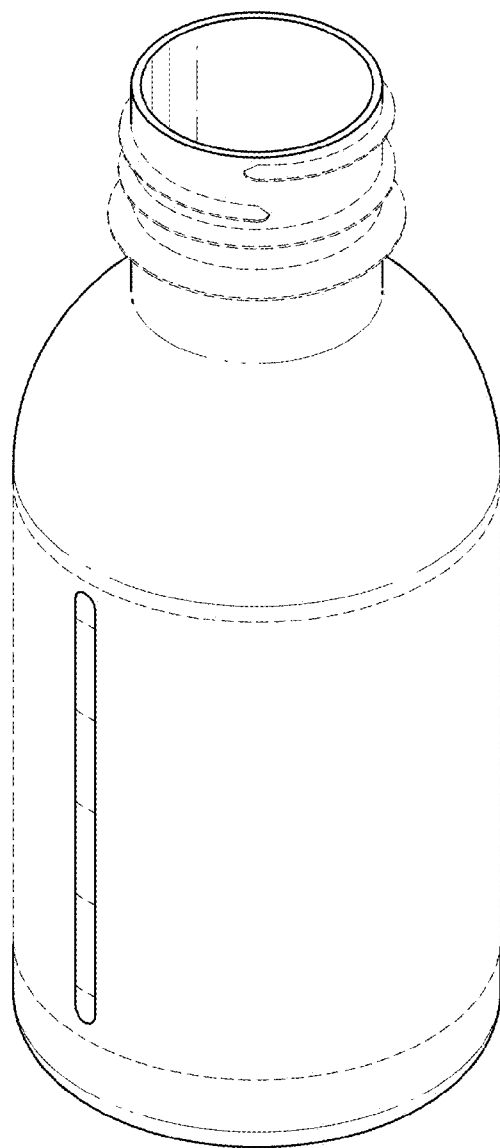




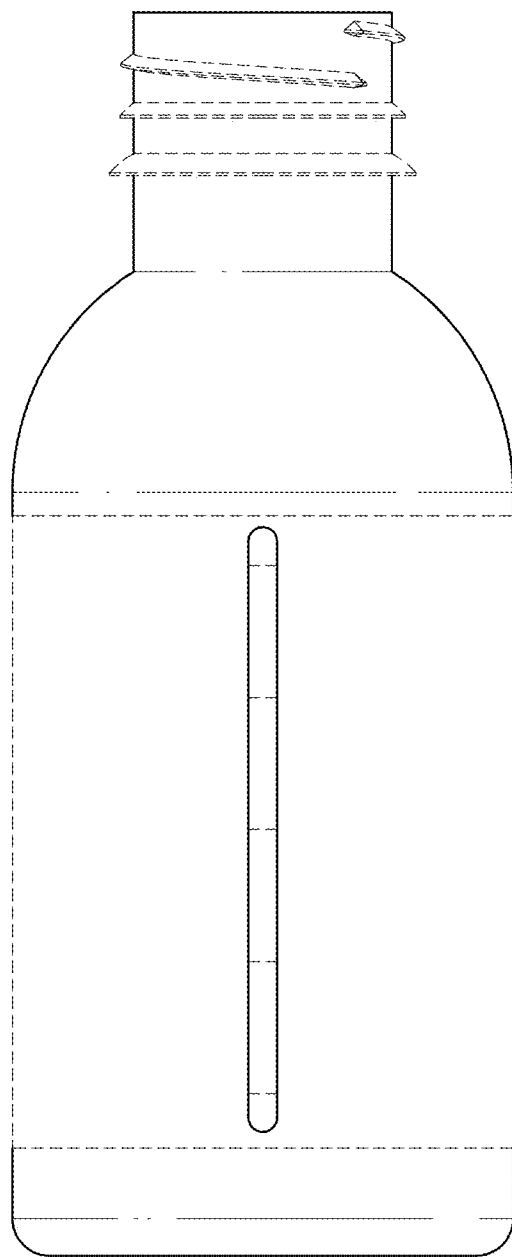
*FIG. 1*



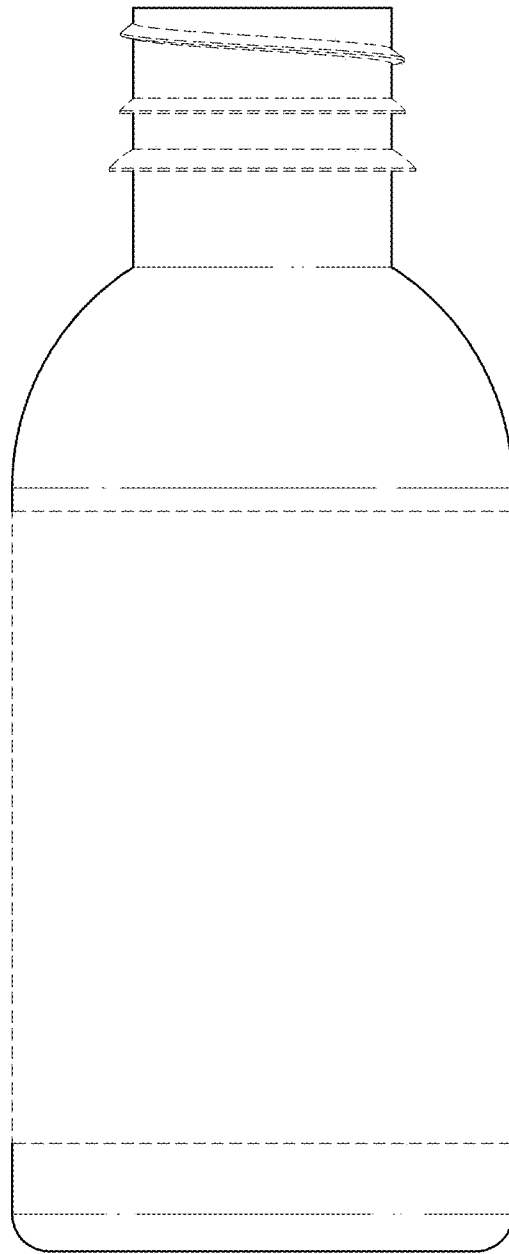
*FIG. 2*



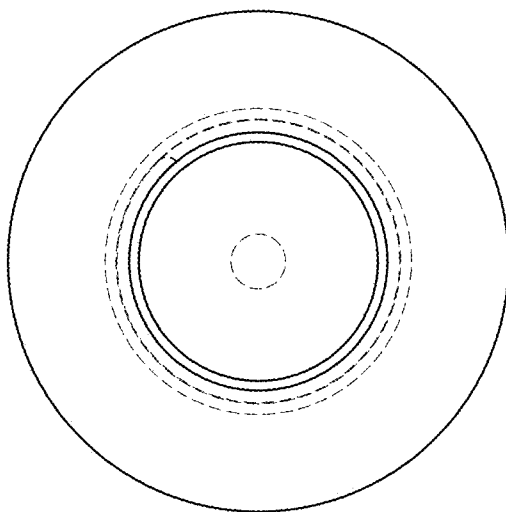
*FIG. 3*



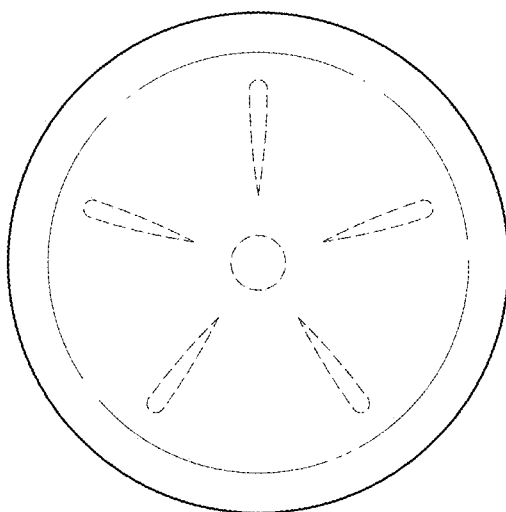
*FIG. 4*



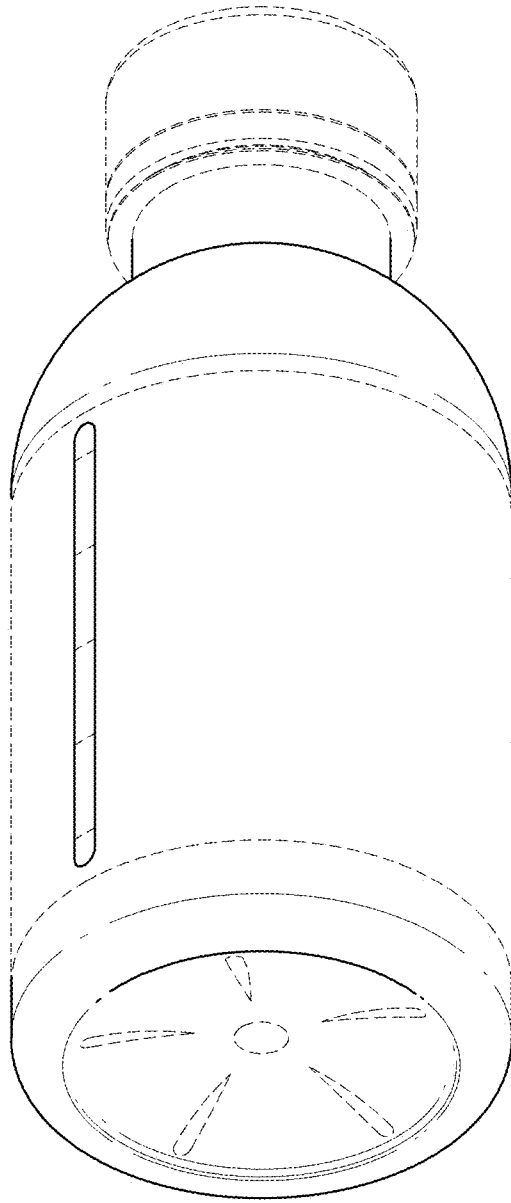
*FIG. 5*



*FIG. 6*



*FIG. 7*



*FIG. 8*