

(No Model.)

2 Sheets—Sheet 1.

J. A. LEAR. MILK PAIL.

No. 593,109.

Patented Nov. 2, 1897.

Fig: 1.

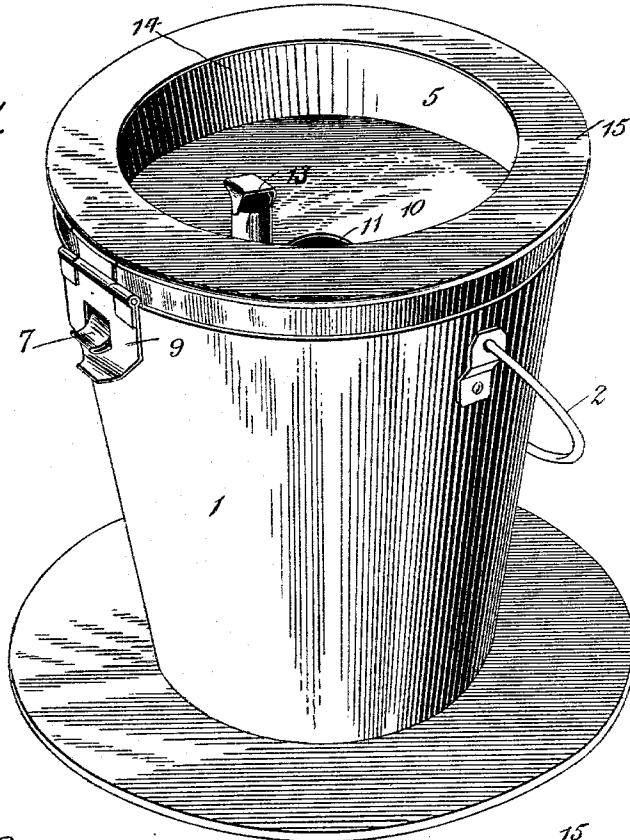
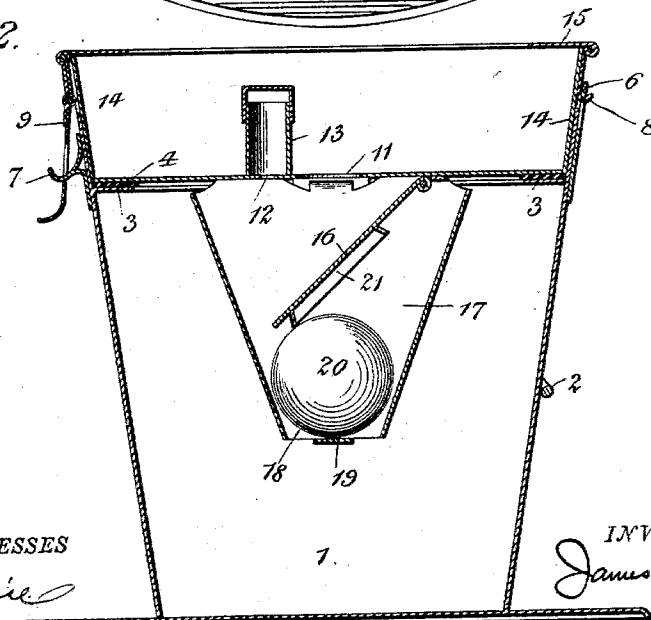

Fig: 2.



WITNESSES
J. A. Rennie
Paca Oberlin

INVENTOR
James A. Lear
 by his Attorney;
John W. Hadburn

(No Model.)

2 Sheets—Sheet 2.

J. A. LEAR.
MILK PAIL.

No. 593,109.

Patented Nov. 2, 1897.

Fig: 3.

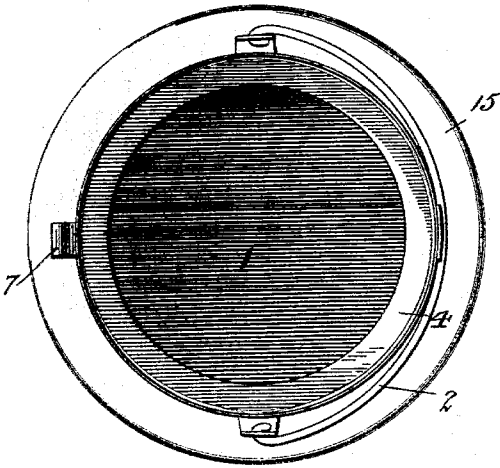

Fig: 4.

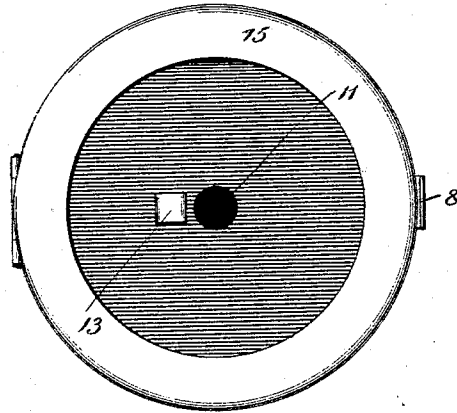

Fig: 5.

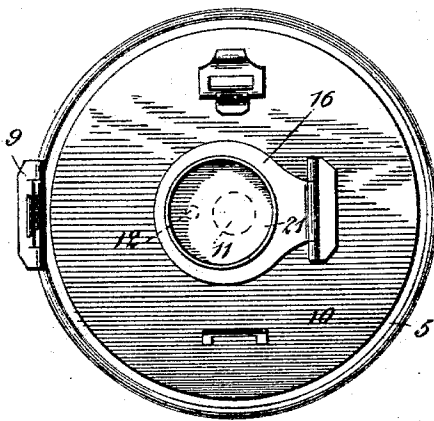
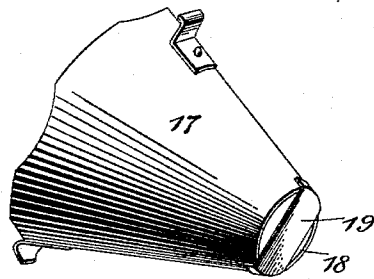

Fig: 6.



WITNESSES

J. A. Rymme.
Paca Oberlin.

INVENTOR,

James A. Lear

By his Attorney

John Weddubam

UNITED STATES PATENT OFFICE.

JAMES ALLEN LEAR, OF LAUDERDALE, LOUISIANA.

MILK-PAIL.

SPECIFICATION forming part of Letters Patent No. 593,109, dated November 2, 1897.

Application filed December 11, 1896. Serial No. 615,303. (No model.)

To all whom it may concern:

Be it known that I, JAMES ALLEN LEAR, a citizen of the United States, residing at Lauderdale, in the parish of St. James and State of Louisiana, have invented certain new and useful Improvements in Milk-Pails; and I do hereby declare the following to be a full, clear, and exact description of the invention, such as will enable others skilled in the art to which it appertains to make and use the same.

My invention relates to improvements in milk-pails, the object of the same being to provide a simple and cheaply-constructed device of this character which is provided with means for preventing the spilling of the contents in case the pail should be upset.

A further object of the invention is to provide means whereby the splashing of the milk from the receiver and the consequent waste thereof are prevented.

The invention consists of a pail having an internal annular ledge thereon, a receiver or top for said pail having a central opening through it and a vent-hole adjacent to said opening, upwardly-extending sides on said receiver and an inwardly-extending annular ledge on the upper ends of said sides, means for securing said receiver to said pail, a valve controlling the openings therein, a funnel detachably connected to the under side of said receiver, and a ball normally fitting within said funnel and adapted to operate said valve when the pail is tilted or upset.

The invention also consists in other details of construction and combinations of parts which will be hereinafter more fully described and claimed.

In the drawings forming part of this specification, Figure 1 represents a perspective view of a milk-pail constructed according to my invention with the receiver shown in place thereon. Fig. 2 is a vertical central longitudinal section through the same. Fig. 3 is a top plan view of the pail with the receiver or top removed. Fig. 4 is a similar view of the receiver or top. Fig. 5 is a bottom plan view of the receiver with the funnel removed; and Fig. 6 is a detail perspective view of the funnel, showing its means of attachment to the under side of the receiver.

Like reference-numerals indicate like parts in the different views.

The pail 1 is provided with the usual bail or handle 2, and has an internal annular ledge 3 secured to it at a point near its upper end. Fitting upon the ledge 3 is a ring or band 4, of rubber, serving as a gasket for preventing the leakage of the contents of the pail when the receiver or cover 5 is in place thereon. The said pail is also provided with a loop 6 at one side and with a hook 7 upon the opposite side. The top or receiver 5 is formed with a hooked strip 8, of metal, which is adapted to fit within the loop 6, and it is also provided with a hinged fastening device 9, which is adapted to fold down over and engage the hook 7 on the opposite side of said pail for holding said top or receiver in position thereon. The receiver 5 is made up of a circular disk 10, of sheet metal, which constitutes the bottom thereof, and is provided with a central discharge-opening 11 and a vent-opening 12, with a covered tubular portion 13 extending upwardly therefrom. The disk 10 has secured to the outer edge thereof a band 14, which extends upwardly from said disk and constitutes the side of the receiver. An annular ring 15 is soldered or otherwise secured to the upper end of the band 14 and extends inwardly therefrom, as clearly shown in the drawings. Hinged to the under side of said bottom piece 10 is a normally open valve 16, which is adapted to close the opening 11 and the vent-hole 12 in case the pail 1 should be tilted or upset.

Removably secured to the under side of the receiver 5 is a funnel 17, whose lower contracted end 18 is partially covered by a strip 19, of sheet metal, upon which rests within said funnel a ball 20 for operating the valve 16 by gravity. The means of connecting the funnel 17 to the receiver 5 is similar in all respects to the means of connecting the receiver 5 to the pail 1. It should be stated that when the top or receiver 5 is in place it rests upon the rubber gasket 4 on the top surface of the internal annular ledge 3 on said pail, so that a close joint is made between said pail and said top or receiver.

From the foregoing description it will be seen that with the parts in place as shown in Fig. 2 of the drawings the pail is capable of receiving the milk, which is supplied thereto through the opening 11 and the funnel 17.

Should the cow kick over the milk-pail or should it be upset from any other cause, the ball 20 in the funnel 17 will fall by gravity upon the under side of the valve 16, closing the latter and preventing the escape of the contents of the pail through the opening 11 or the vent-hole 12. The sides 14 and the inwardly-projecting ring 15 on the upper end thereof serve to prevent the milk from splashing out over the sides of the receiver and the consequent loss of the same. When it is desired to remove the cover or receiver from the pail 1, it may be readily done by raising the fastening device 9 out of engagement with the hook 7 and slipping the hook 8 from the loop 6. The funnel 17 may also be removed in a similar manner from the under side of the receiver 5 when it is desired to fill the same.

The device is extremely simple in construction, is made almost entirely of sheet metal, and any of the parts may be readily renewed should they become worn or broken. It should be stated that the under side of the valve 16 is provided with an annular strip of metal 21, which forms a socket for receiving the ball 20 and preventing the same from slipping out of contact with said valve when the pail is in its tilted or upset position.

Having now described my invention, what I claim as new, and desire to secure by Letters Patent, is—

1. The combination with a pail, of a top or receiver therefor having a filling-opening extending therethrough, a normally open valve controlling said opening, a movable member separate from the valve itself for closing said valve, thrown into operation by the tilting of said pail on its side, and a housing for said movable member, substantially as described.

2. The combination with a pail of a top or receiver therefor having a filling-opening extending therethrough, a normally open valve controlling said opening, a ball adapted to engage the under side of said valve for closing the latter when the pail is tilted over upon one side, and a housing for said ball, substantially as and for the purpose described.

3. The combination with a pail, of a top or receiver therefor having a filling-opening extending therethrough, a normally open valve controlling said opening, a funnel upon the under side of said receiver beneath said opening, and a ball fitting within said funnel partially closing the opening in the lower end thereof and adapted to engage the under side of said valve for closing the latter when the pail is tilted over upon one side, substantially as and for the purpose described.

4. The combination with a pail, of a top or receiver therefor having a filling-opening extending therethrough, a normally open valve controlling said opening, a funnel upon the under side of said receiver beneath said opening, a strip of metal partially closing the lower end of said funnel, a ball fitting within said funnel and resting upon said strip, said ball being adapted to engage the under side of said valve for closing the latter when said pail is turned over upon one side, substantially as and for the purpose described.

5. The combination with a pail, of a receiver or top therefor having a filling-opening therein, means for securing said receiver to the upper end of said pail, a valve pivoted to the under side of said receiver for controlling the opening therein, a metallic ring secured to the under side of said valve, a funnel removably secured to the under side of said receiver beneath said valve, a strip partially covering the opening in the lower end of said funnel, and a ball fitting loosely within said funnel normally resting upon the strip at the lower end thereof and adapted to engage the under side of said valve for closing the opening in said receiver when said pail is tipped over upon one side, substantially as and for the purpose described.

6. The combination with a pail having an internal annular ledge near the upper end thereof, and a rubber gasket resting upon said ledge, of a top or receiver removably secured to the upper end of said pail and resting upon the gasket on said ledge and provided with a filling-opening located centrally of the bottom thereof and a vent-hole adjacent to said filling-opening, an inwardly-extending ring or strip of metal secured to the upper edges of the sides of said top or receiver, a valve pivoted to the under side of said receiver for controlling said central opening and said vent-hole, a funnel removably secured to the under side of said receiver beneath said valve, a strip partially closing the opening in the lower end of said funnel, and a ball fitting loosely within said funnel and adapted to engage the under side of said valve for closing the latter when said pail is tipped over upon one side.

In testimony whereof I have signed this specification in the presence of two subscribing witnesses.

JAMES ALLEN LEAR.

Witnesses:

ALFRED PLAISANA,
JOSEPH DAMARÉ.