

L. K. JOHNSON & A. A. LOW.
TYPE SETTING APPARATUS.

No. 523,745.

Patented July 31, 1894.

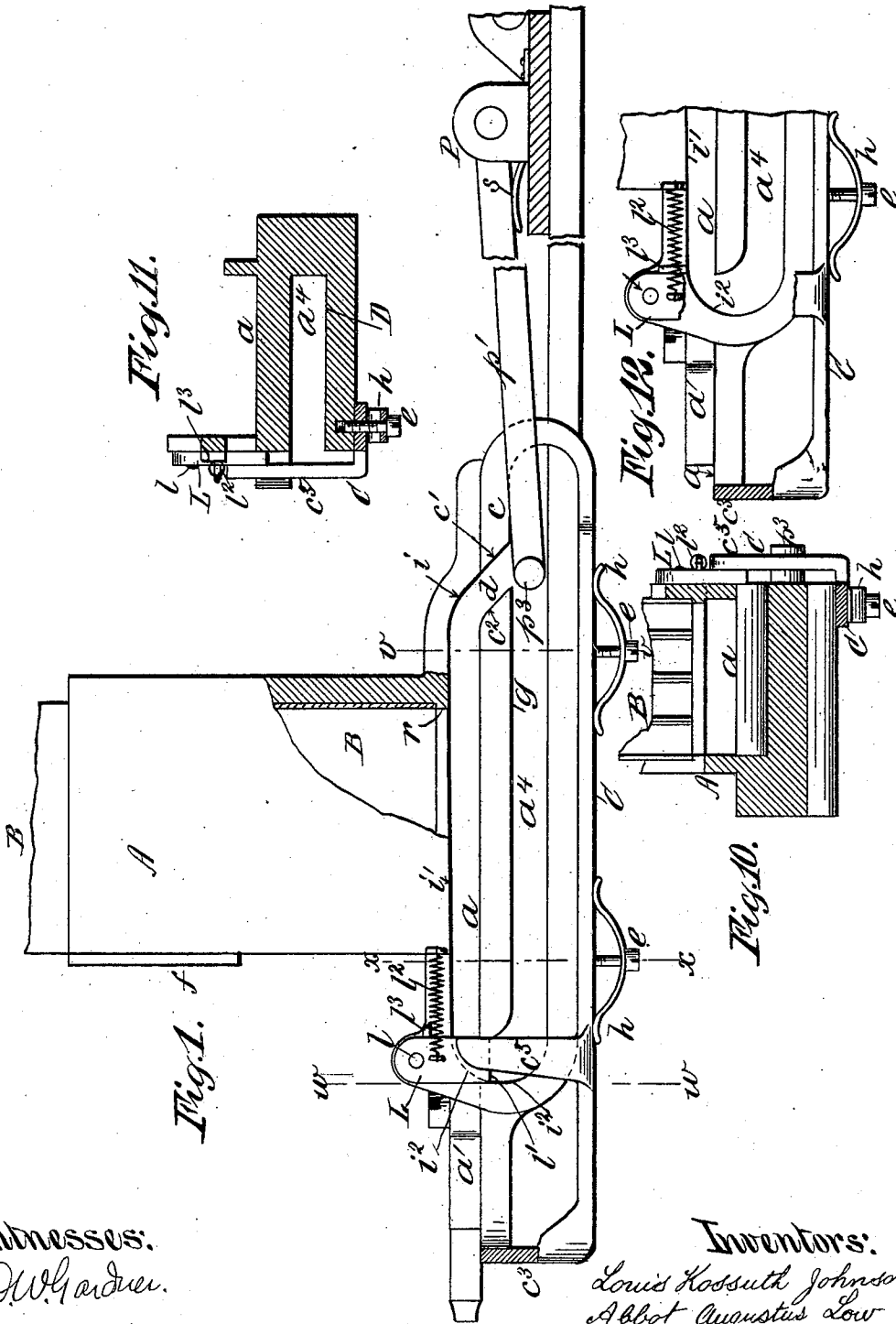

Witnesses:
D. W. Gardner.
G. J. Puffer

Inventors:
Louis Kossuth Johnson
Abbot Augustus Low
 By their Attorney
George Williams Mearl

L. K. JOHNSON & A. A. LOW.
TYPE SETTING APPARATUS.

No. 523,745.

Patented July 31, 1894.

Fig. 2.

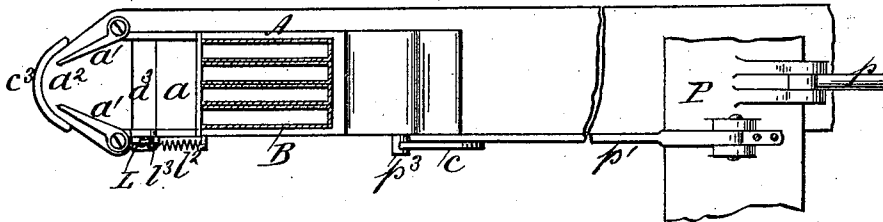

Fig. 5.

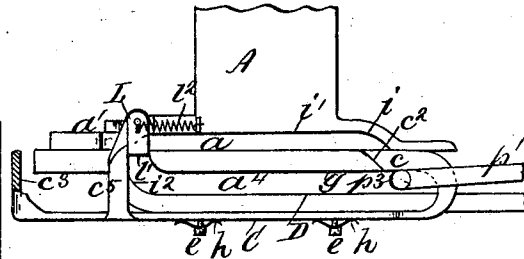

Fig. 3.

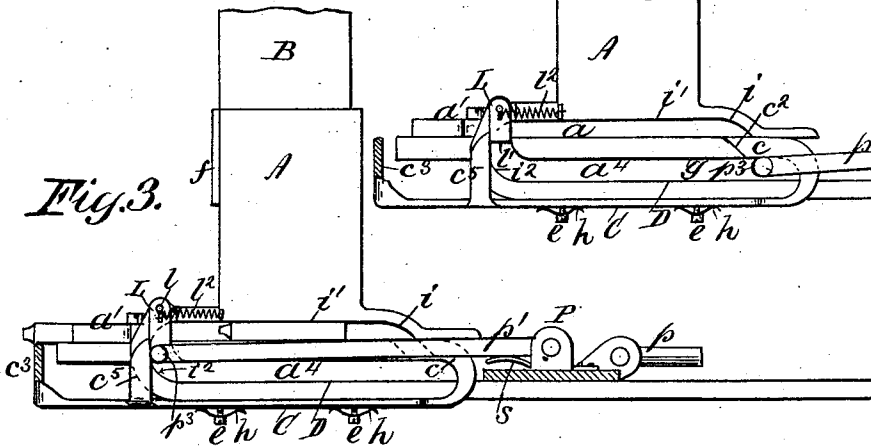
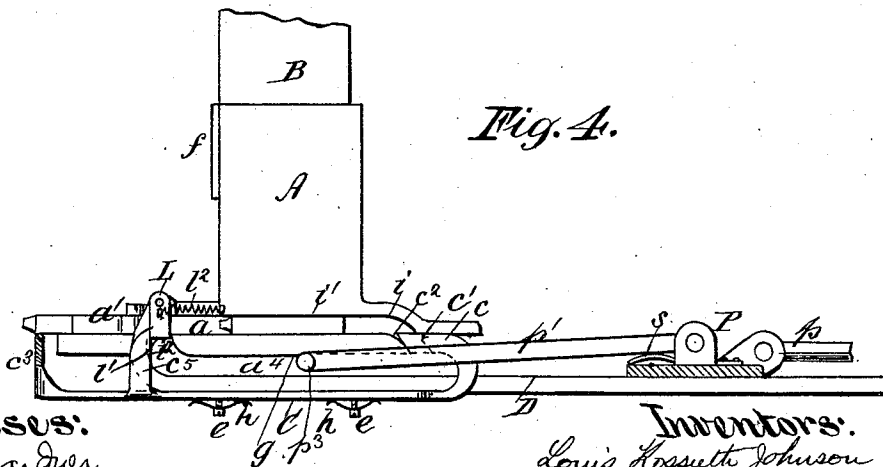

Fig. 4.



Witnesses:
 D. W. Gardner
 S. S. Rafines

Inventors:
 Louis Kessuth Johnson
 Abbot Augustus Low,
 By their Attorney,
 George William Math

L. K. JOHNSON & A. A. LOW.
TYPE SETTING APPARATUS.

No. 523,745.

Patented July 31, 1894.

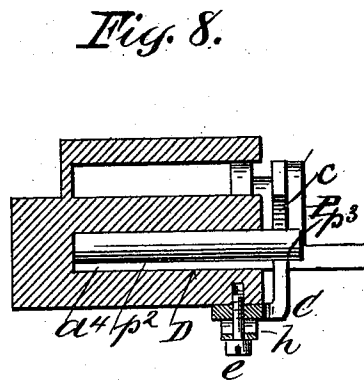
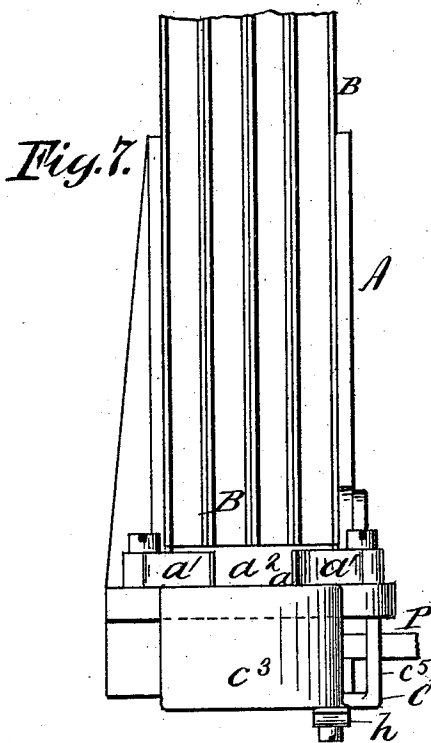
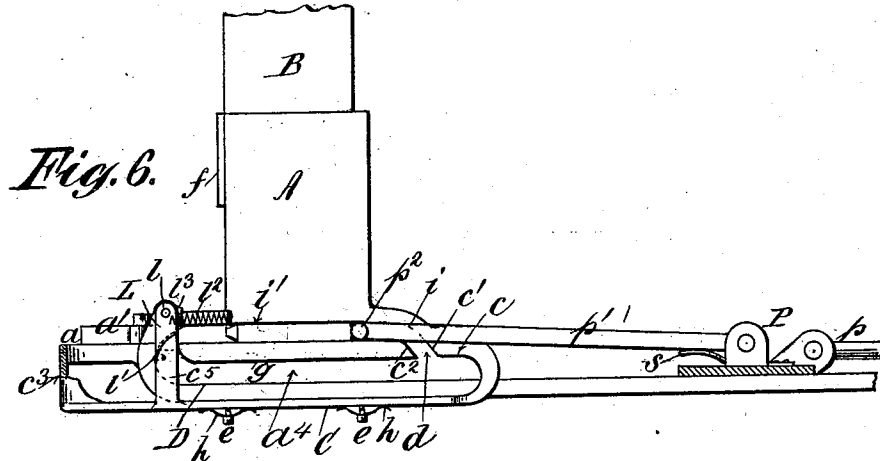

Witnesses:
D. W. Gardner
J. S. Raper

Inventors:
Louis Rossuth Johnson
Abbot Augustus Low,
 By their attorney,
George William Meath

UNITED STATES PATENT OFFICE.

LOUIS KOSSUTH JOHNSON AND ABBOT AUGUSTUS LOW, OF BROOKLYN,
ASSIGNORS TO THE ALDEN TYPE MACHINE COMPANY, OF NEW
YORK, N. Y.

TYPE-SETTING APPARATUS.

SPECIFICATION forming part of Letters Patent No. 523,745, dated July 31, 1894.

Application filed January 24, 1894. Serial No. 497,856. (No model.)

To all whom it may concern:

Be it known that we, LOUIS KOSSUTH JOHNSON and ABBOT AUGUSTUS LOW, citizens of the United States, residing in the city of Brooklyn, in the county of Kings and State of New York, have invented certain new and useful Improvements in Type-Setting Apparatus, of which the following is a specification, sufficient to enable others skilled in the art to which the invention appertains to make and use the same.

Our invention relates to the class of type setting apparatus in which a plurality of types are forwarded simultaneously and made to converge together as they advance into position to be grasped collectively between the thumb and finger of the compositor for removal to the stick.

In our applications, Serial No. 496,396, filed January 10, 1894, and Serial No. 497,854, filed January 24, 1894, we describe and claim certain means for relieving the hand of the compositor of the labor involved in forwarding the types, and for insuring the forwarding and presentation of new types as fast as those preceding are removed from the case.

In our recent applications named the main object sought is to throw a constantly reciprocating pusher into action to forward the types through an instrumentality actuated by the fingers of the operator while grasping the preceding types for removal, and in our last application, Serial No. 497,855, filed January 24, 1894, this is effected by means of an inclined plane interposed in the path of the pusher finger at the latter part of its retractile stroke, said inclined plane being set by a finger push bar.

In all our previous devices the reciprocating pusher has traveled upon the floor of its table or upon the floor of the type supporting platform. In the present case the pusher finger travels on the under side of the guiding surfaces which control it continuously. In fact a distinguishing feature of our present application is that the pusher finger is positively controlled in all positions, and cannot fail to do the work allotted to it.

Our present invention consists in combining and arranging with a plurality of type

containing channels, and with means for converging the types upon a common support, a constantly reciprocating pusher which tends constantly to rise to the type platform; a port opener and closer operated in one direction by the fingers of the compositor while in the act of grasping or removing the preceding types and in the other by the pusher finger itself; a guiding surface arranged to centralize the pusher finger with relation to the heels of the types; and an automatic latch or trap for insuring the descent of the pusher-finger at the end of its forward stroke while resetting the push-bar to close the pusher finger port at the rear.

In the accompanying drawings, Figure 1, is an elevation, upon an enlarged scale, of our improved type forwarding mechanism. Fig. 2, is a plan, on a reduced scale, of the parts in the position shown in Fig. 1. Fig. 3, is a side elevation of the mechanism showing the pusher finger in the act of re-setting the push-bar. Fig. 4, is a similar view showing the position of the parts during the retractile stroke of the pusher finger. Fig. 5, is a detail, showing the pusher finger opposite the port when the latter is closed; Fig. 6, an elevation showing the pusher finger in contact with the heels of the lowest types; Fig. 7, a front view upon the same scale as Fig. 1. Fig. 8, is a vertical section upon plane of line *v, v*, Fig. 1. Fig. 9, is a plan in detail of the push bar, reduced scale. Fig. 10, is a vertical section upon plane of line *w, w*, Fig. 1; Fig. 11, a vertical section upon plane of line *x, x*, Fig. 1; Fig. 12, a detail showing the curved guiding surface for the pusher finger at the forward end of its stroke.

The socket piece or support A, for the type containing channels B, may be of any convenient or desired construction, that shown in the drawings being substantially the same as in our application hereinbefore referred to, excepting that the partitions are dispensed with, and the channels rest against each other, being supported by a rear shoulder *r*, and a front plate *f*, as in the patent to Louis K. Johnson, No. 494,573, dated April 4, 1893. By adopting this construction we are enabled to bring the lower edges of the type contain-

ing channels down to the lowest point, and to put them in collectively without danger of upsetting the types. Since the channels are all drawn upon equally in our system of word setting all necessity for a separate support for each channel is obviated.

The type supporting platform a , extends out beyond the front of the socket piece A, and is provided with the converging side walls a' , a'' , ending in the port a^2 , through which the forward ends of the types are made to project by the forward stroke of the type finger p^2 , when the latter is brought into action.

The type platform a , is slotted transversely at a^3 , just behind the position which the heels of the types occupy when fully forwarded. This slot a^3 , opens into a passage way a^4 , the bottom of which is formed by the top of the main platform D, upon which the pusher bar P, rests, in the arrangement shown in the drawings, although the pusher may be supported in any convenient or well known manner, the essential feature being the employment of a constantly reciprocating type-forwarding device actuated by suitable mechanism.

The pusher-bar P, is shown as reciprocated through the medium of a connecting rod p . To its upper side is pivotally connected one end of an arm p' , having the lateral pusher finger p^2 , projecting from its other extremity. A spring s , is interposed between the upper side of the pusher bar P, and the under side of the vibratory arm p' , the result being that the pusher finger p^2 , tends constantly to rise to a higher level, and therefore travels upon the under side of the type platform a , and along the lower edge of the upper guide surface g . This upward pressure of the pusher is slight being but little more than sufficient to lift the pusher finger p^2 , and arm p' , to their work, so that the frictional contact and wear are little if any in excess of the gravity pusher heretofore used. Instead of the flat spring s , shown any other form of spring pressure may be substituted, or a counterweight may be employed in lieu thereof, if preferred.

The type platform a , extends backward slightly beyond the rear of the type containing channels B. The pusher-finger rests normally against the under side of the type platform a , traveling back and forth thereunder as the pusher-bar P, is reciprocated. The retractile movement of the pusher-bar P, carries the pusher-finger p^2 , beyond the rear extremity of the type platform a , however, at the extreme limit of the stroke, and the pusher-finger would immediately spring upward above the type platform were it not for the presence ordinarily, of the cut-off c , supported upon the rear end of the finger push plate C. This cut-off c , when the push-plate C, is in its forward position rests with its inclined edge c' , against the inclined edge c^2 , of the type platform a , as illustrated in Figs. 4 and

5. When the finger push plate C, is pushed back until the finger-plate c^3 , rests against the front edge of the type platform a , as in Figs. 1 and 6, the cut-off c , occupies such a position that a port d , is formed between the inclined surfaces c' , c^2 . When the parts are in this position the pusher finger p^2 , when it reaches the end of its retractile stroke, is raised by the spring s , through the port d , and into contact with the curved surface i , at the rear of the holder A, which curved surface i , guides the pusher finger p^2 , to the horizontal guide surface i' , formed by the lower edge of the holder A. This guide surface i' , is so formed as to centralize the pusher finger p^2 , with relation to the type that the pusher finger will encounter the heels of the type midway of the width of the latter, as illustrated in Fig. 6. As the forward stroke of the pusher continues the types are forwarded until their front ends project through the port a^2 , similar to the manner set forth in our prior applications. Just prior to the completion of the forward stroke the pusher finger encounters the curved surface i^2 , which guides it downward below the type platform a . At the same time it also encounters the edge of a spring latch L, pivoted at l , to the frame. This latch L, yields before the pusher finger until the latter has been guided by the inclined surface i^2 , below its lower edge l' , when, under the action of the retractile spring l^2 , it springs back into its normal position, thereby preventing the possibility of the pusher finger rising under the influence of the spring s , before the pusher finger has been fairly drawn under the type supporting shoulder a . The latch L, is held in its normal position by a stop l^3 ; and may be of any suitable form or construction other than that shown, its function being simply to insure positively the descent of the pusher finger while the latter is resetting the finger push plate C. This resetting of the finger push plate C, is effected by reason of the contact of the extension p^3 , of the pusher finger p^2 , coming in contact with the arm c^5 , projecting upward from the plate C. The arm c^5 , is so placed with relation to the cut-off c , and to the finger push c^3 , that it is moved by the latter part on the forward stroke of the pusher a distance equal to that of the width of the port d , so as to cause the cut-off c , to close the port, as illustrated in Fig. 3,—the spring latch L, having sprung back above the pusher finger just prior to the completion of its forward stroke.

In Fig. 1, which is enlarged for the purpose of illustration, the pusher finger p^2 , is represented at the instant just prior to its ascent through the port d . In reality it commences to ascend immediately the port is reached, if open, but it is shown in an arbitrary position in this view in order to clearly show the port.

The finger push plate C, may be supported upon the frame in any suitable manner. As shown in the drawings it is formed with longitudinal slots c^4 , through which pass the

shanks of set screws *e*, which press the double ended spring *h*, up against the under side of the plate C, thereby supporting the said plate C, against the bottom of the table D, while 5 permitting of its longitudinal movement under the pressure of the fingers of the compositor in one direction and the stroke of the pusher finger in the other.

What we claim as our invention, and desire 10 to secure by Letters Patent, is—

1. In a type setting apparatus the combination of a plurality of type containing channels; a type platform, common to all the types, formed with a transverse slot; a reciprocating 15 type forwarder arranged to advance over said type platform and to descend through said transverse slot at the end of its forward stroke; and a spring latch for preventing the return of the type pusher finger, substantially in the manner and for the purpose described. 20

2. In a type setting apparatus the combination of a plurality of type containing channels; a type platform, common to all the types, formed with a transverse slot; a reciprocating 25 type forwarder arranged to advance over said type platform and to descend through said transverse slot at the end of its forward stroke; a spring or equivalent device which tends constantly to raise the pusher finger, and a controlling surface against the under side of 30 which the type finger travels, substantially in the manner and for the purpose described.

3. In a type setting apparatus the combination of a plurality of type containing channels; a type platform, common to all the types, formed with a transverse slot; a reciprocating 35 type forwarder arranged to advance over said type platform and to descend through said transverse slot at the end of its forward stroke; a spring or equivalent device which tends constantly to raise the pusher finger; and a cut-off operated to close the port, through which 40 the pusher finger rises, by the finger pusher itself during the completion of its forward stroke, and to open the said port under the action of the fingers of the operator, substantially in the manner and for the purpose described. 45

4. In combination with type forwarding

mechanism substantially such as described, 50 the finger push-plate C, formed with the cut-off *c*, arm *c*⁵, and finger plate *c*³, for the purpose and substantially in the manner described.

5. In combination with type forwarding 55 mechanism substantially such as described, the push finger plate C, formed with the cut-off *c*, re-setting arm *c*⁵, and the finger plate *c*³, and having the longitudinal slots *c*⁴, together with the bow springs *h*, and set screws *e*, arranged and operated substantially in the manner and for the purpose described. 60

6. In type setting apparatus the combination of a plurality of type containing channels; a type platform, common to all the types, 65 formed with a transverse slot; a reciprocating type forwarder arranged to advance over said type platform and to descend through said transverse slot at the end of its forward stroke; a spring or equivalent device which tends constantly to raise the pusher finger; guiding 70 surfaces which act in conjunction with the said means for raising the pusher finger to control the path thereof, and an inclined surface arranged to guide the pusher finger 75 downward at the end of its stroke, substantially in the manner and for the purpose described.

7. In a type setting apparatus the combination of a plurality of type containing channels; a type platform, common to all the types, 80 formed with a transverse slot; a reciprocating type forwarder; a spring or equivalent device which tends constantly to raise the pusher finger; guiding surfaces which act in conjunction with the said means for raising the 85 pusher finger; an inclined surface arranged to guide the pusher finger downward at the end of its stroke; and a spring latch arranged to act in conjunction with said inclined surface to positively insure the descent of the 90 pusher finger, substantially in the manner and for the purpose described.

LOUIS KOSSUTH JOHNSON.
ABBOT AUGUSTUS LOW.

Witnesses:

D. W. GARDNER,
GEORGE WILLIAM MIATT.