

- [54] CONTAINER AND LID CONSTRUCTION FOR INDICATING LID REMOVAL
- [75] Inventor: Leslie Stephan Marco, Des Plaines, Ill.
- [73] Assignee: Illinois Tool Works Inc., Chicago, Ill.
- [22] Filed: Aug. 24, 1973
- [21] Appl. No.: 391,187
- [52] U.S. Cl. 220/276, 215/32
- [51] Int. Cl. B65d 17/00, B65d 43/02, B65d 17/20
- [58] Field of Search 220/27, 60 R, 47, 48, 53, 220/54; 215/32, 42

[57] ABSTRACT

A plastic container and cover assembly which is opened with mutilation or severing of an outer top peripheral portion of the container, and reclosed with the original cover for reuse; the peripheral portion of the cover is of inverted U-shape providing an inner flange for frictional or snap interlocking with the container body wall and an outer dependent flange extending into an upwardly open groove or trough on the container, the horizontal flange portion of the cover overlying an outward radial rim portion on the container which rim portion is peripherally weakened continuously or at intervals to be severed therealong upon removal of the container grooved portion and cover with discarding of the severed grooved portion and permissive reuse of the cover to close the container, and with the weakened portion severed along at least a substantial portion thereof following any attempt to pry the cover from the container grooved portion, thus indicating a mutilation of that portion of the container as a tell-tale.

[56] **References Cited**

UNITED STATES PATENTS

3,276,616	10/1966	Lurie	220/27
3,362,570	1/1968	Geiger	220/27
3,378,172	4/1968	Nelson	220/27
3,609,263	9/1971	Clementi	220/60 R
3,730,382	5/1973	Heisler	220/60 R

Primary Examiner—William I. Price
 Assistant Examiner—Joseph Man- Fu Moy
 Attorney, Agent, or Firm—R. W. Beart; Edward L. Benno

10 Claims, 6 Drawing Figures

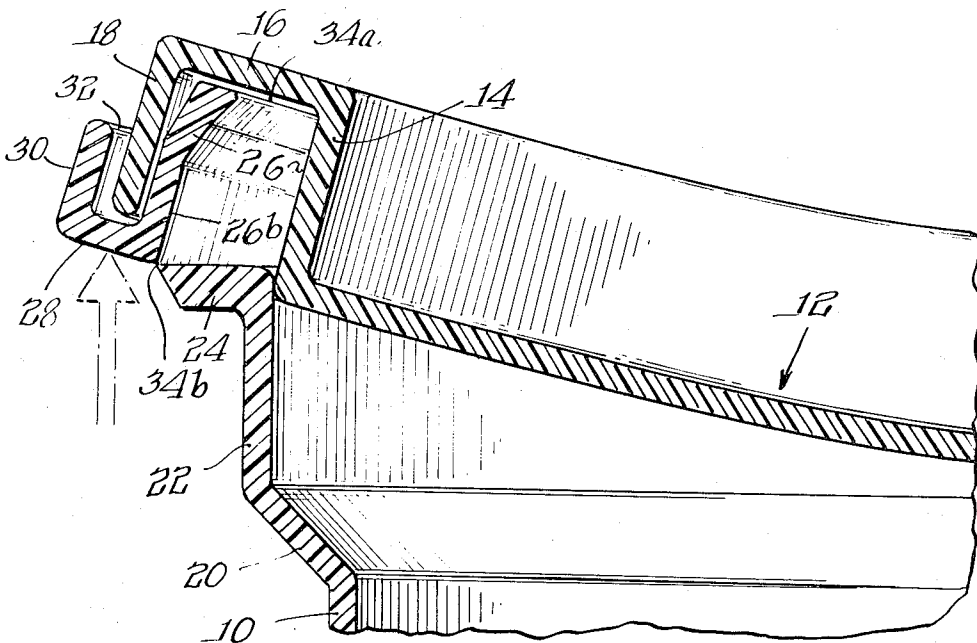

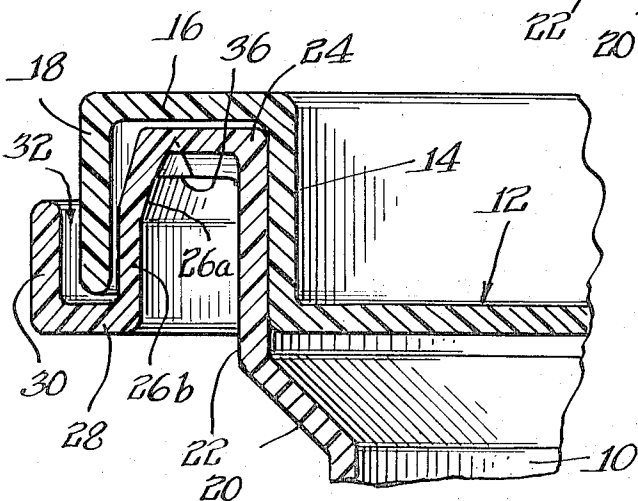
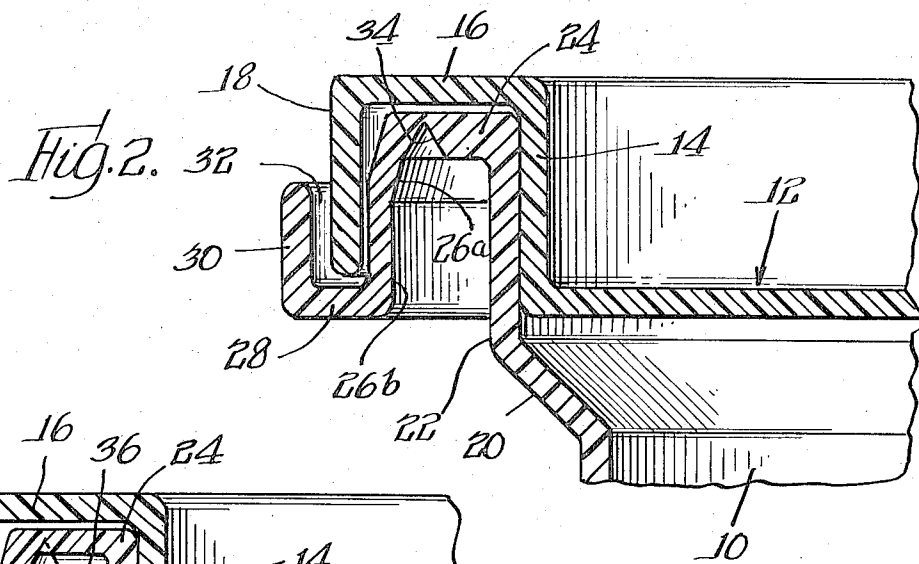
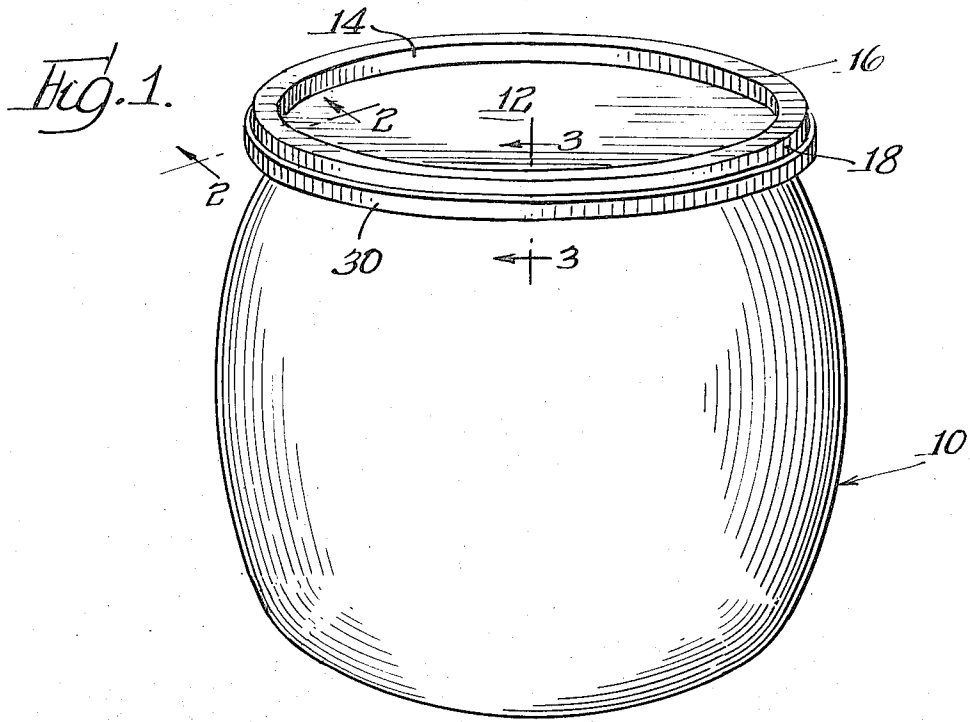

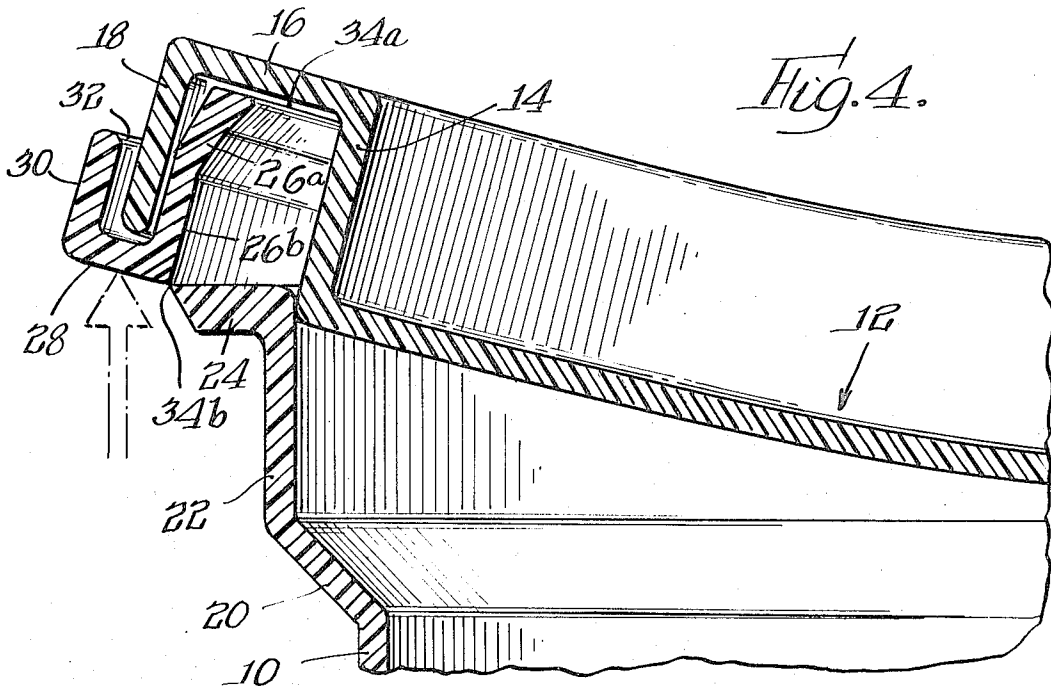

Fig. 4.

Fig. 5.

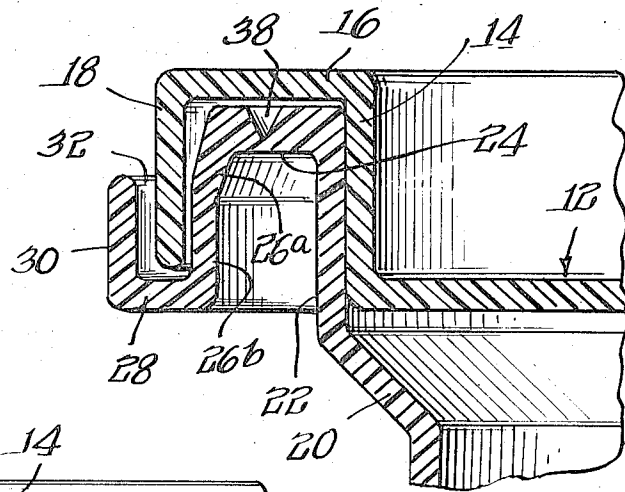
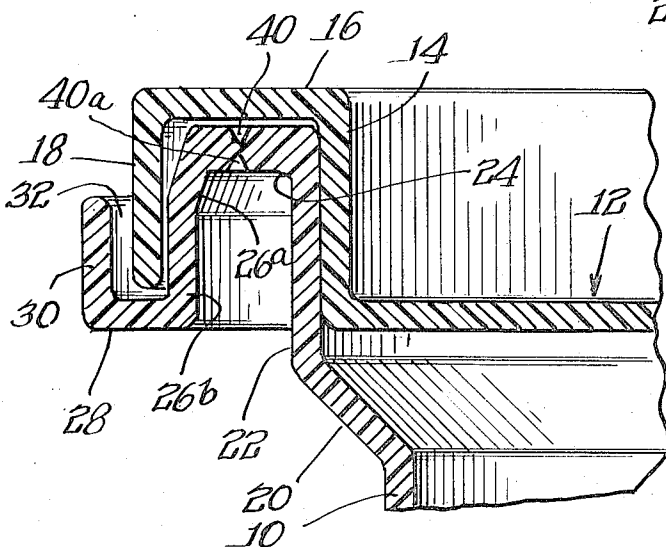

Fig. 6.



CONTAINER AND LID CONSTRUCTION FOR INDICATING LID REMOVAL

BACKGROUND OF THE INVENTION

There are various forms of sealed containers with severable sealing means between the cover and a container body. In some of these arrangements, there are sealed outward flanges on the cover and body with weakening to permit removal of an outer strip so that the cover can then be removed from the container and reapplied if desired. In other arrangements, an outer portion is sealed to a container body flange which is weakened to permit removal of the body flange and the outer cover leaving an inner cover which may be removed for access to the container contents and then reapplied if desired. And, too, there are arrangements of reversely folded flanges with one folded portion removable along a line of weakness to permit removal of the cover and the remaining folded portion. In most of these arrangements, the lines of weakness are external and sometimes in view to facilitate opening of the container by the purchaser.

SUMMARY OF THE INVENTION

According to the present invention, there is provided a plastic reusable container and cover assembly which may be opened and reclosed with the original cover intact.

An object of the invention is to provide such an assembly wherein complete removal of the cover will effect separation of a peripheral portion of the container from the body portion thereof, thus preventing reclosure after such intentional tampering without leaving a tell-tale omission of a portion of the container when viewed with others on display.

Another object of the invention is to provide an assembly of the above type wherein the separable portion of the container is joined to the body portion by a line of weakness normally hidden from view.

A further object of the invention is to provide such an assembly with the outer cover flange projecting into an upwardly facing groove formation on the separable portion of the container tending to deter tampering by finger lifting of the cover from the container and resulting in at least partial separation of the portion of the separable body portion if a prying tool is inserted into the groove formation in an effort to pry the cover from the container.

The above and other objects of the invention will in part be obvious and will be hereinafter more fully pointed out in connection with the detail description of the drawing in which

FIG. 1 is a perspective view of the container and cover assembly;

FIG. 2 is an enlarged sectional view taken along line 2—2 of FIG. 1 showing a line of weakness for separation of a peripheral portion of the container from the body portion thereof;

FIG. 3 is a similar sectional view taken along line 3—3 of FIG. 1 illustrating permissive discontinuity of the lines of weakness shown in FIG. 2;

FIG. 4 is a sectional view similar to FIG. 2 but showing the cover partially removed from the container and the resultant separation of a peripheral portion of the container from the body portion along the line of weakness;

FIG. 5 is a sectional view similar to FIG. 2 but showing a modified line of weakness;

FIG. 6 is a sectional view similar to FIG. 2 but showing a further modified line of weakness.

DETAILED DESCRIPTION OF THE PREFERRED EMBODIMENTS

With reference to the accompanying drawings, and particularly FIGS. 1 and 2 at this time, the container 10 may take various shapes but is illustrated as of somewhat bulbous cylindrical shape and is preferably formed of thin wall plastic material, such as polystyrene. The container is closed by a cover or lid 12 of similar plastic material. The cover includes a vertical wall portion 14 upstanding from the central closing portion thereof and merging with a horizontal outwardly extending top wall portion 16. This wall portion 16 terminates in a depending peripheral flange 18, thus providing an inverted generally U-shaped peripheral portion. The invention contemplates that the lid 12 may have other cross-sectional configurations but must include an inner wall 14, an upper wall 16 and a depending skirt 18.

The container body includes an outwardly and upwardly inclined peripheral wall 20 merging with an upstanding vertical wall portion 22 within which the telescoped cover wall portion 14 may have a snug friction fit or an interfitting rib and groove or shoulder arrangement between these cover and body walls for a snap fit, or other conventional arrangements therebetween. If desired known venting means may also be provided between the cover and container body. The wall portion 22 merges with a horizontal outward flange or rim portion 24 which underlies the top wall 16 of the cover when applied to the container. The outer periphery of the wall or flange 24 joins with an outwardly and downwardly inclined wall 26a in turn merging with a vertical portion 26b which combine with the wall portions 24 and 22 to provide an inverted U-shape within the U-shaped portion of the cover. At the bottom of the wall portion 26b, there is an outward radial wall 28 merging with an upstanding peripheral flange 30 which define, with the wall portion 26b, an upwardly facing groove or trough formation 32 into which the lower portion of the cover flange 18 extends. This groove may be upwardly open, as illustrated, or the flange 30 may be turned inwardly or otherwise positioned closer to the outer surface of the cover flange 18 when it is desired to prevent any accumulation of foreign matter therein.

Normal operation of the container and cover assembly shown in FIGS. 1, 2 and 3 will be described with reference to FIG. 4. The horizontal rim portion 24 of the cover is weakened by a groove, as V-shaped, or cut-out 34 to provide a line of weakness at the apex thereof so that the outer portion thereof, including the groove formation 32, will be severed from the container upon removal of the cover as will be described. This weakening can be accomplished in various ways. The groove 34 may be circumferentially continuous around the underside of the rim or it may be discontinuous for a short distance, as at 36 in FIG. 3, and such discontinuity may be at spaced intervals to leave a series of relatively weakened or even slit sections alternating with non-weakened portions. The weakening grooves themselves may be variously formed as by the groove 38 in the upper face of the rim as shown in FIG. 5, or by opposed grooves 40, 40a in opposite faces of the rim as shown

in FIG. 6. To open the container, the container groove forming walls are lifted in the direction of the arrow in FIG. 4 and this will, in turn, lift the cover 12 along with the remnant peripheral grooved portion of the container which will be separated from the remaining portion of the rim 24 along the line of weakness provided at the apex of the groove 34, or the grooves 38, 40 and 40a, as the case may be. Upon complete removal of the cover, the remnant container rim portion, that is, the remaining wall portions 26a, 26b, 28, 30, can be discarded, and the original cover 12, without alteration, can be used as a reclosure for the container body.

There are those who surreptitiously inspect the contents of containers by tampering on the display shelf in a store and often without intending to purchase. Tilting of the cover and container groove formation for this look-see purpose will rupture the weakened line as described above at least along a substantial portion of the peripheral extend thereof. The primary locking fit is between the contacting surfaces of the cover wall 14 and the container wall portion 22 when the cover is closed, and that locking fit should be such that substantial circumferential fracture and possibly some radial fracture of the groove 34 will occur before the locking fit is opened. Thus, when repositioning the cover and the container groove formation walls from the look-see tilted position, distortion and misalignment of the remnant container rim portion to the cover 12 will be obvious.

I claim:

1. A plastic container assembly comprising a body portion having an open end defined by a generally vertical inner wall and an outer depending generally vertical wall joined to the inner wall by a top wall portion, and with the lower portion of the depending outer wall terminating in an upwardly facing trough formation, and a cover closing the open end of the body portion and having radially spaced inner and outer walls interconnected by a top cover flange, said inner walls of said container and said cover being formed to cooperate in a manually releasable interlocking fit, said outer depending wall of the cover projecting into the upwardly facing trough formation, said outer depending wall of the cover and the outer upwardly extending segment of said upwardly facing trough formation being relatively formed to substantially prevent access by a person's finger to the lower edge of said outer depending wall of the cover, and means for weakening said top wall portion of the body portion around the periphery thereof

for complete severance therealong upon authorized removal of the cover and trough formation from the body portion and discarding of the trough formation permitting the original cover to be used as a reclosure for the body portion.

2. A container assembly as claimed in claim 1, wherein the top wall portion of the body portion is provided with groove means extending at least partially therethrough to provide the peripheral weakening means.

3. A container assembly as claimed in claim 2, wherein the groove means is interrupted at spaced intervals around the periphery thereof.

4. A container assembly as claimed in claim 1, wherein the top wall portion of the body portion is provided with groove means extending completely therethrough at spaced intervals around the periphery thereof.

5. A container assembly as claimed in claim 1, wherein the top wall portion of the body portion is of sufficient radial extent to radially space the inner and outer walls of the body portion and provide an inverted U-shaped configuration fitting within the inverted U-shaped configuration provided by the inner and outer walls and the cover flange.

6. A container assembly as claimed in claim 5, wherein the top wall portion of the body portion is provided with groove means extending at least partially therethrough to provide the peripheral weakening means.

7. A container assembly as claimed in claim 6, wherein the groove means extends from the under face of the top wall portion of the body portion.

8. A container assembly as claimed in claim 7, wherein there is provided additional groove means extending from the upper face of the top wall portion toward the groove means in the under face thereof.

9. A container assembly as claimed in claim 1, wherein the inner and outer walls of the body portion are radially spaced apart and the top wall portion is provided with groove means extending from the upper face thereof to provide the peripheral weakening means.

10. A container assembly as claimed in claim 1, wherein there is relatively loose interfitting between the outer cover wall and the trough formation to facilitate separation.

* * * * *

50

55

60

65