



(51) International Patent Classification:

A61M 31/00 (2006.01) A61M 25/10 (2006.01)  
A61M 25/01 (2006.01) A61M 29/02 (2006.01)  
A61M 25/09 (2006.01) A61M 39/08 (2006.01)

(21) International Application Number:

PCT/US2010/057736

(22) International Filing Date:

23 November 2010 (23.11.2010)

(25) Filing Language:

English

(26) Publication Language:

English

(71) Applicant (for all designated States except US): **TREUS MEDICAL, INC** [US/US]; 330 Nimitz Avenue, Redwood City, CA 94061 (US).

(72) Inventors; and

(75) Inventors/Applicants (for US only): **VAN DAM, Jacques** [US/US]; 432 Portofino Drive, #402, San Carlos, CA 94070 (US). **JULIAN, Chris** [US/US]; 546 Woodland Ridge, Los Gatos, CA 95033 (US). **KREIDLER, Marc** [US/US]; 645 E. McKinley Avenue, Sunnyvale, CA 94086 (US). **KNISLEY, Eric** [US/US]; 2850 Windmill Ranch Road, Weston, FL 33331 (US). **MILROY, James, Craig** [US/US]; 184 Heather Lane, Palo Alto, CA 94303 (US). **OHLINE, Robert, Matthew** [US/US]; 330 Nimitz Avenue, Redwood City, CA 94061 (US). **SWINEHART, Charles** [US/US]; 1282 Vinci Park Way, San Jose, CA 95131 (US).

(74) Agent: **O'REGAN, Cecily, A.**; Greenberg Traurig, LLP, 2450 Colorado Avenue, Suite 400 East, Santa Monica, California 90404 (US).

(81) Designated States (unless otherwise indicated, for every kind of national protection available): AE, AG, AL, AM, AO, AT, AU, AZ, BA, BB, BG, BH, BR, BW, BY, BZ, CA, CH, CL, CN, CO, CR, CU, CZ, DE, DK, DM, DO, DZ, EC, EE, EG, ES, FI, GB, GD, GE, GH, GM, GT, HN, HR, HU, ID, IL, IN, IS, JP, KE, KG, KM, KN, KP, KR, KZ, LA, LC, LK, LR, LS, LT, LU, LY, MA, MD, ME, MG, MK, MN, MW, MX, MY, MZ, NA, NG, NI, NO, NZ, OM, PE, PG, PH, PL, PT, RO, RS, RU, SC, SD, SE, SG, SK, SL, SM, ST, SV, SY, TH, TJ, TM, TN, TR, TT, TZ, UA, UG, US, UZ, VC, VN, ZA, ZM, ZW.

(84) Designated States (unless otherwise indicated, for every kind of regional protection available): ARIPO (BW, GH, GM, KE, LR, LS, MW, MZ, NA, SD, SL, SZ, TZ, UG, ZM, ZW), Eurasian (AM, AZ, BY, KG, KZ, MD, RU, TJ, TM), European (AL, AT, BE, BG, CH, CY, CZ, DE, DK, EE, ES, FI, FR, GB, GR, HR, HU, IE, IS, IT, LT, LU, LV, MC, MK, MT, NL, NO, PL, PT, RO, RS, SE, SI, SK, SM, TR), OAPI (BF, BJ, CF, CG, CI, CM, GA, GN, GQ, GW, ML, MR, NE, SN, TD, TG).

Declarations under Rule 4.17:

— as to applicant's entitlement to apply for and be granted a patent (Rule 4.17(ii))

Published:

— with international search report (Art. 21(3))

(54) Title: BILIARY SHUNTS, DELIVERY SYSTEMS, AND METHODS OF USING THE SAME

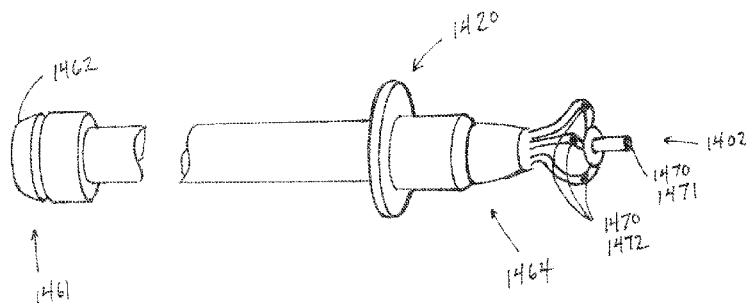

FIG. 14

(57) Abstract: The application discloses devices, delivery tools, systems, and methods for treating biliary disease. Device comprise, for example, a component configured for deployment between a gallbladder and location within a gastrointestinal tract of a patient which has a proximal end and a distal end with a lumen extending therethrough. A method of deploying the device can be achieved by, for example, creating a duct or fistula between a gallbladder lumen and a portion of a gastrointestinal tract; and providing for drainage from the gallbladder to the gastrointestinal tract.



## BILIARY SHUNTS, DELIVERY SYSTEMS, AND METHODS OF USING THE SAME

### CROSS-REFERENCE

[0001] This application has related subject matter to U.S. Utility Patent Application No. **12/277,491** filed November 25, 2008, and PCT Application **PCT/US2008/84888** filed November 26, 2008, entitled “Biliary Shunts, Delivery Systems, Methods of Using the Same, and Kits Therefor” by Jacques Van Dam, J. Craig Milroy, and R. Matthew Ohline; Patent Application No. **12/277,443**, filed November 25, 2008, and PCT Application **PCT/US2008/84830** filed November 26, 2008, entitled “Methods, Devices, Kits and Systems for Defunctionalizing the Gallbladder” by Jacques Van Dam, J. Craig Milroy, and R. Matthew Ohline and Patent Application No. **12/277,338**, filed November 25, 2008, and PCT Application **PCT/US2008/84865** filed November 26, 2008, entitled, “Methods, Devices, Kits and Systems for Defunctionalizing the Cystic Duct” by Jacques Van Dam, J. Craig Milroy, and R. Matthew Ohline, which applications are incorporated herein by reference.

### FIELD OF THE INVENTION

[0002] The invention described in this patent application addresses challenges confronted in the treatment of biliary disease. Biliary disease includes conditions affecting the gallbladder, cystic duct, and common bile duct.

#### **BILIARY SYSTEM FUNCTION AND ANATOMY:**

[0003] Bile is a greenish-brown digestive fluid produced by the liver **10** illustrated in **FIGS. 1-2**, and is vital for the digestion of fatty foods. Bile is secreted by liver cells and collected by a network of ducts that converge at the common hepatic duct **12**. While a small quantity of bile drains directly into the lumen of the duodenum **30** (the section of small intestine immediately downstream of the stomach), most travels through the common hepatic duct **12** and accumulates in the lumen of the gallbladder **14**. Healthy gallbladders are pear-shaped sacs with a muscular wall that, on average, measure 10 cm in length and can store approximately 50 ml of fluid within its lumen. When fatty foods are ingested, the hormone cholecystokinin (CCK) is released, which causes the gallbladder **14** to contract. Contraction of the gallbladder **14** forces bile to flow from the gallbladder **14**, through the cystic duct **16**, into the common bile duct **18**, out the papilla **28**, and finally into the duodenum **30** of the small intestine. Here, it mixes and reacts with the food that exits the stomach (chyme). The Sphincter of Oddi **26** controls secretions from the liver **10**, pancreas **24**, and gallbladder **14** into the duodenum **30** of the small intestine. The opening on the inside of the descending

duodenum **30** after the Sphincter of Oddi **26** is called the major duodenal papilla **28** (of Vater). Together, the biliary ducts, the gallbladder **14**, the cystic duct **16** and the common bile duct **18** comprise the biliary system (**FIG. 1**).

[0004] The pancreas **24** is a gland organ in the digestive and endocrine system of vertebrates. It is both an endocrine gland (producing several important hormones, including insulin, glucagon, and somatostatin), as well as an exocrine gland, secreting pancreatic juice containing digestive enzymes that pass to the small intestine. These enzymes help in the further breakdown of the carbohydrates, protein, and fat in the chyme. The pancreatic duct **22**, or duct of Wirsung, is a duct joining the pancreas **24** to the common bile duct **18** to supply pancreatic juices which aid in digestion provided by the exocrine pancreas. The pancreatic duct **22** joins the common bile duct **18** just prior to the major duodenal papilla **28**, after which both ducts perforate the medial side of the second portion of the duodenum **30** at the major duodenal papilla **28**.

#### **BILIARY DISEASE:**

[0005] The most common problem that arises in the biliary system is the formation of gallstones, a condition called cholelithiasis. Approximately 20 million Americans have gallstones, and about 1-3% will exhibit symptoms in any given year. In the U.S., gallstones are more common among women, with 25% of women having gallstones by the age of 60 and 50% by the age of 75. Pregnancy and hormone replacement therapy increase the risk of forming gallstones. Prevalence is lower for American men: approximately 25% will develop gallstones by the age of 75. In the U.S., gallstones are responsible for the highest number of hospital admissions due to severe abdominal pain.

[0006] Gallstones **20, 20'** (**FIG. 2**) are most often composed of cholesterol, but may also be formed from calcium bilirubinate, in which case they are called pigment stones. They range in size from a few millimeters to several centimeters, and are irregularly shaped solids resembling pebbles. They can form in the gallbladder **14**, cystic duct **16**, and/or the common bile duct **18**. By themselves, gallstones do not necessarily result in disease states. This is the case 90% of the time. However, stones can cause infection and inflammation, a condition known as cholecystitis, which is generally the result of restricting or blocking the flow of bile from the gallbladder **14** and common bile duct **18**, or the fluids secreted by the pancreas **24**.

[0007] Gallbladder disease may be chronic, and patients who suffer from this may periodically experience biliary colic. Symptoms include pain in the upper right abdomen near the ribcage, nausea, and/or vomiting. The pain may resolve within an hour of onset, may prove unresponsive to over-the-counter medicines, and may not decrease with changes

of position or the passage of gas. Recurrence is common, with pain often recurring at the same time of day, but with frequency of less than once per week. Fatty or large meals may cause recurrence several hours after eating, often awakening the patient at night. Patients may elect to suffer from these symptoms for very long periods of time, such as years or even decades.

**[0008]** Patients with chronic cholecystitis have gallstones and low-grade inflammation. Untreated, the gallbladder **14** may become scarred and stiff over time, leading to a condition called dysfunctional gallbladder. Patients who have chronic cholecystitis or dysfunctional gallbladder may experience gas, nausea, and abdominal discomfort after meals, and chronic diarrhea.

**[0009]** Acute cholecystitis (a surgical emergency) develops in 1-3% of those with symptomatic gallstone disease, and is due to obstruction of the common bile duct **18** or cystic duct **16** by stones or sludge. Symptoms are similar to biliary colic, though they are more severe and persistent. Pain in the upper right abdomen can be constant and severe, the intensity may increase when drawing breath, and it may last for days. Pain may radiate to the back, under the breastbone or the shoulder blades, and it may be perceived on the left side of the abdomen. In addition to nausea and vomiting, one third of patients experience fever and chills. Complications from acute cholecystitis can be serious and life threatening, and include gangrene, abscesses, perforation of the gallbladder **14** which can lead to bile peritonitis, pus in the gallbladder wall (empyema), fistulae, and gallstone ileus (when a gallstone creates a blockage in the small intestine).

**[0010]** When gallstones **20'** become lodged in the common bile duct **18** (**FIG. 2**), the condition is known as choledocholithiasis. Symptoms for this condition include pain, nausea and vomiting, and some patients develop jaundice, have dark urine and/or lighter stools, rapid heartbeat, and experience an abrupt drop in blood pressure. These symptoms can also be accompanied by fever, chills, and/or severe pain in the upper right abdomen. Complications from choledocholithiasis can also be very serious, and include infection of the common bile duct **18** (cholangitis) and inflammation of the pancreas **24** (pancreatitis).

**[0011]** A smaller patient population suffers from gallbladder disease that occurs in the absence of gallstones. This condition, called acalculous gallbladder disease, can also be chronic or acute. Chronic acalculous gallbladder disease, also called biliary dyskinesia, is thought to be caused by motility disorders that affect the gallbladder's ability to store and release bile. Acute acalculous gallbladder disease occurs in patients who suffer from other serious illnesses which can lead to inflammation of the gallbladder **14** because of a reduction

in the supply of blood to the gallbladder *14* or a reduced ability to contract and empty bile into the duodenum *30*.

[0012] Cancer can also develop in the gallbladder *14*, though this condition is rare.

Gallstones have been found in 80% of patients with gallbladder cancer. Gallbladder cancer typically develops from polyps, which are growths inside the gallbladder *14*. When polyps 15 mm across or larger are observed, the gallbladder is removed as a preventive measure. Polyps smaller than 10 mm are widely accepted as posing low risk and are not generally removed. When detected early, before the cancer has spread beyond the mucosa (inner lining) of the gallbladder, the 5-year survival rate is approximately 68%. However, gallbladder cancer is not usually detected until patients are symptomatic, by which time the disease is more advanced.

#### **TREATMENT OF BILIARY DISEASE:**

[0013] The most effective treatment for biliary disease has been surgical removal of the gallbladder *14*, a procedure called cholecystectomy. Surgical removal of the gallbladder *14* is indicated for patients who experience a number of less severe gallstone attacks, cholecystitis, choledocholithiasis, pancreatitis, acalculous biliary pain with evidence of impaired gallbladder *14* emptying, those at high risk for developing gallbladder cancer, and those who have previously undergone endoscopic sphincterotomy for common bile duct stones. Other treatment modalities exist and are frequently used, but gallbladder disease tends to recur in the majority of patients who forgo cholecystectomy and pursue alternatives. Removal of the gallbladder *14* is highly successful at permanently eliminating biliary disease. Cholecystectomy is one of the most commonly performed procedures on women. The gallbladder *14* is not an essential organ, and after a period of adjustment post surgery, patients tend to return to more or less normal digestive function.

[0014] Cholecystectomy can be performed either as open surgery, which requires a single larger incision in the upper right abdomen, or laparoscopic surgery, in which several small instruments are inserted through much smaller incisions in the abdomen. Approximately 80% of cholecystectomies are performed laparoscopically. The primary benefits of this minimally invasive approach are faster recovery for the patient, and a reduction in overall healthcare costs. Patients who receive laparoscopic cholecystectomy are usually released the same day. By contrast, patients receiving open cholecystectomies typically spend 5-7 days in a hospital before release. 5-10% of laparoscopic procedures convert to open procedures when difficulties arise, such as injury to major blood vessels, inadequate access, inadequate visualization, previous endoscopic sphincterotomy, and thickened gallbladder wall.

Complications from cholecystectomy (open or laparoscopic) include bile duct injuries (0.1-0.5% for open, 0.3-2% with a declining trend for laparoscopic), pain, fatigue, nausea, vomiting, and infection. In up to 6% of cases, surgeons fail to identify and remove all gallstones present.

**[0015]** In some cases, the degree of infection and inflammation prevents patients from undergoing immediate cholecystectomy. In these cases, the gallbladder *14* must be treated with antibiotics and anti-inflammatory agents, and drained through a tube into a reservoir outside the abdomen. Placement of this tube occurs in a procedure called percutaneous cholecystostomy, in which a needle is introduced to the gallbladder *14* through the abdomen, fluid is withdrawn, and a drainage catheter is inserted. This catheter drains into an external bag which must be emptied several times a day until the tube is removed. The drainage catheter may be left in place for up to 8 weeks. In cases where no drainage catheter is inserted, the procedure is called gallbladder aspiration. Since no indwelling catheter is placed, the complication rate for gallbladder aspiration is lower than that of percutaneous cholecystostomy.

**[0016]** Treatment methodologies other than cholecystectomy include expectant management, dissolution therapy, endoscopic retrograde cholangiopancreatography (ERCP) with endoscopic sphincterotomy, and extracorporeal shockwave lithotripsy (ESWL).

**[0017]** Expectant management is appropriate for patients who have gallstones but no symptoms, and for non-emergency cases with less severe symptoms. This approach is not recommended when patients are in high risk categories (*e.g.* high risk for gallbladder cancer) or have very large gallstones (*e.g.* greater than 3 cm).

**[0018]** Oral dissolution therapy involves the administration of pills containing bile acids that can dissolve gallstones. This approach is only moderately effective, and the rate of recurrence of gallstones after completion of treatment is high. It is not appropriate for patients with acute inflammation or stones in the common bile duct (more serious conditions). Dissolution therapy tends to be more effective for patients with cholesterol stones, and is sometimes used in conjunction with lithotripsy. Despite its relative ineffectiveness, it is costly: treatment can last up to 2 years and the drugs cost thousands of dollars per year.

**[0019]** Related to oral dissolution therapy is contact dissolution, a procedure that involves injection of a solvent such as methyl tert-butyl ether (MTBE) directly into the gallbladder *14*. This approach is highly effective at dissolving gallstones, but patients may experience severe burning pain.

[0020] ERCP (endoscopic retrograde cholangiopancreatography) is a procedure in which an endoscope is introduced through the mouth of a patient, past the stomach to the papilla **28** (FIG. 2), where the common bile duct **18** empties into the duodenum **30**. The overall goal of the procedure is to insert instruments and tools into the common bile duct **18** via the papilla **28** in order to treat biliary disease. Typically, endoscopic sphincterotomy is performed, which is a procedure that enlarges the opening of the papilla **28** in the small intestine. This can be accomplished surgically or via balloon dilation. Contrast agent is introduced into the common bile duct **18** to visualize the biliary tree fluoroscopically. Tools for clearing blockages, such as mechanical lithotripsy devices, can be deployed to crush gallstones and remove the resulting debris. Drainage catheters and stents may also be inserted to facilitate the drainage of bile past obstructions. Complications from this challenging procedure occur at a rate of 5-8%, and include recurrence of stone formation, pancreatitis, infection, bleeding, and perforation.

[0021] Extracorporeal shockwave lithotripsy (ESWL) is a technique in which focused, high-energy ultrasound is directed at the gallbladder **14**. The ultrasound waves travel through the soft body tissue and break up the gallstones. The resulting stone fragments are then usually small enough to pass through the bile duct into the small intestine. Oral dissolution therapy is often used in conjunction with ESWL. This treatment is not in common use, as less than 15% of the patient population are good candidates. However, ESWL is used to treat patients who are not candidates for surgery. Complications from ESWL include pain in the gallbladder area, pancreatitis, and failure of the gallstone fragments to pass into the small intestine.

#### SUMMARY OF THE INVENTION

[0022] An aspect of the disclosure is directed to devices for treating biliary disease. Suitable devices comprise a component configured for establishing fluid communication between a gallbladder and a target location within a gastrointestinal tract of a mammal, the component having a proximal end and a distal end with a lumen extending therethrough, a tubular section with a radially extending proximal flange and a radially extending distal flange wherein at least one of the proximal flange and distal flange is disc shaped and at least one of the proximal flange and the distal flange has a plurality of radially extending elements. The devices can be configured for deployment by an endoscope, a needle, a guidewire, a guidance catheter, and/or a dilatation balloon. Endoscopes can further be adapted to comprise an ultrasound device. A system for treating biliary disease is also contemplated which comprises a device for configuring a duct between a gallbladder and a gastrointestinal tract of a patient

having a proximal end and a distal end with a lumen extending therethrough between. In some aspects the devices can be configured to further comprise a delivery mechanism for delivering a substance. Deployment of these devices can, in some instances, cause a conduit to be formed between a gallbladder lumen and a target location within the gastrointestinal tract.

**[0023]** Another aspect of the disclosure is directed to a biliary disease treatment device comprising: a component configured for establishing fluid communication between a gallbladder and a target location within a gastrointestinal tract of a mammal, the component having a proximal end and a distal end with a lumen extending therethrough, a tubular section with a radially extending proximal flange and a radially extending distal flange wherein at least one of the proximal flange and distal flange is disc shaped and at least one of the proximal flange and the distal flange has a plurality of radially extending elements. The conduit can, for example, be formed between a lumen of the gallbladder and a target location within the gastrointestinal tract, such as proximal to a duodenum.

**[0024]** Still another aspect of the disclosure is directed to devices for treating biliary disease. Suitable devices comprise a component configured for establishing fluid communication between a gallbladder and a target location within a gastrointestinal tract of a mammal, the component having a proximal end and a distal end with a lumen extending therethrough, a tubular section with a radially extending proximal flange and a radially extending distal flange wherein at least one of the proximal and distal flange is comprised of a first material and the tubular section is comprised of a second material. The devices can be configured for deployment by an endoscope, a needle, a guidewire, a guidance catheter, and/or a dilatation balloon. Endoscopes can further be adapted to comprise an ultrasound device. A system for treating biliary disease is also contemplated which comprises a device for configuring a duct between a gallbladder and a gastrointestinal tract of a patient having a proximal end and a distal end with a lumen extending therethrough between. In some aspects the devices can be configured to further comprise a delivery mechanism for delivering a substance. Deployment of these devices can, in some instances, cause a conduit to be formed between a gallbladder lumen and a target location within the gastrointestinal tract.

**[0025]** Devices according to any one of the configurations disclosed can be formed from a bioresorbable material. Moreover, the devices can be removable and/or expandable. The devices can also be configurable in one or more configurations selected from a deployment configuration, a delivery configuration and a final configuration. Moreover, the devices can be configured such that a profile of the device changes between said configurations.

Additionally, or in the alternative, a cross-sectional area of the device can be variable along a length of the devices. In some configurations a component or implant can be configured such that it has a flareable end, suitable flareable ends include ends that are generally hemispherical. Additionally, components or implants can comprise a configurable retainable feature. In some aspects, components or implants can comprise one or more clips configured to secure the components or implants at one or more positions. In some configurations, one or more fenestrations may be provided. Moreover, the lumen or conduit can be configurable to provide restrictable fluid flow or to provide for a valve, such as a flow-restrictor or one-way valve. Any of the configurations of the device can be constructed such that the device is flexible. The system or device can also be configured to include a generally elongate tube that is adapted and configured to extend into the gastrointestinal tract. Configurations that include an elongate tube can be configured such that the tube is patent at a first end; the patent first end can be for placement adjacent the gallbladder. In still other configurations, the elongate tube is not patent at a second end. Moreover, the tube can be configured such that it has an adjustable length. Additionally, one or more fluid control components can be provided to the designs. Additionally, an enlargeable portion comprising two or more legs can be provided.

**[0026]** Another aspect of the disclosure is directed to a kit for treating biliary disease comprising a duct forming component positioned between a gallbladder and a gastrointestinal tract. The kit can comprise any of the devices or systems described herein. Additionally, compounds can be provided for delivery to a tissue. Compounds or materials include, but are not limited to, for example, one or more of each of sclerosing agents, antibiotics, inflammatory agents, anti-inflammatory agents, biocompatible gels, and biocompatible foams. Additionally, a catheter, guidewire, needle, guidance catheter or balloon catheter can be provided. In some aspects, the kit can also include an ablation device. Additional components of the kits include, for example, one or more of each of a pair of scissors, a scalpel, a swab, a syringe, a hemostat, a lubricant, a needle, a snare, an antiseptic, and an anesthetic.

**[0027]** Yet another aspect of the disclosure is directed to a method for treating biliary disease. A method of treating biliary disease comprises: (a) using an endoscope to place at least one of a guidewire, a needle, a guidance catheter, and a dilatation catheter between an access lumen in a body and a gallbladder; (b) inserting a delivery catheter over the at least one of guidewire, needle, guidance catheter, and dilatation catheter and into the gallbladder; (c) delivering a component configured for establishing fluid communication between a

gallbladder and a target location within a gastrointestinal tract of a mammal, the component having a proximal end and a distal end with a lumen extending therethrough, a tubular section with a radially extending proximal flange and a radially extending distal flange wherein at least one of the proximal flange and distal flange is disc shaped and at least one of the proximal flange and the distal flange has a plurality of radially extending elements; and (d) positioning the component between the access lumen in the body and the gallbladder to create a lumen therebetween. Additionally, the method can comprise the step of delivering a substance to the gallbladder via the duct. Additional method steps include delivering a device to the gallbladder through the duct. Suitable devices to be delivered include one or more of a stent, a drug-coated stent, a catheter, a needle, a guidance catheter, a balloon dilatation catheter and/or a guidewire. In some cases, the step of creating the duct further comprises the step of inserting a device in communication between the gastrointestinal tract and the gallbladder lumen. The step of creating the duct between a gallbladder lumen and a portion of a gastrointestinal tract can further comprise the step of inserting a conduit between the gallbladder lumen and the portion of the biliary system. In some aspects, the method further comprises the step of forming a biological duct *in situ* from a patient's tissue. As will be appreciated by those skilled in the art, the step of inserting a conduit between the gallbladder lumen and the portion of the gallbladder tract can occur at a first time and the step of forming the biological duct *in situ* from the patient's tissue occurs at a second time remote from the first time. Moreover the methods can further comprise the step of providing a seal to prevent fluid from leaking into a peritoneum. Additionally the gallbladder can be defunctionalized *in situ*, such as by delivering a substance or material into a space within the gallbladder. Suitable substances or materials include, but are not limited to, gels and foams. In some instances, the delivered substances can be activated *in situ*. Additionally, an amount of material can be delivered to fill, or substantially fill, the gallbladder lumen. Additionally, in some instances, the step of defunctionalizing is achieved by one or more of sclerosing or necrotizing a tissue within the gallbladder which can, for example, be achieved by an ablation technique.

**[0028]** Still another aspect of the disclosure is directed to a method of delivering a device to treat biliary disease comprising: (a) using an endoscope to place a guidewire between an access lumen in a body and a gallbladder; (b) inserting a delivery catheter over the guidewire and into the gallbladder; (c) delivering a conduit on the catheter; and (d) positioning the conduit between the access lumen in the body and the gallbladder to create a lumen therebetween. The methods can also include the step of forming a biological duct *in situ*

from a patient's tissue. Additionally, the step of positioning the conduit can occur at a first time and the step of forming the biological duct *in situ* from the patient's tissue occurs at a second time remote from the first time. Some methods can further comprise the step of passively retaining a distal end of the guidewire in the gallbladder while the guidewire is used to deliver additional elements. In some instances, the methods include the step of retaining a distal end of the guidewire within the gallbladder. In some methods, gallstones are removed through the created lumen. In other methods, a substance is delivered to the gallbladder via the created lumen. In some instances, the substance occupies the gallbladder lumen and can be one or more of antibiotics, inflammatory agents, and anti-inflammatory agents. Methods may also include preventing bile from entering the or a gallbladder lumen. Additionally, the gallbladder may be localized via endoscopic ultrasound, in some instances. Moreover, it may be useful to access the gallbladder via the gastrointestinal tract. A suitable location for accessing the gallbladder via the gastrointestinal tract would be to access the gallbladder at a duodenum. With any of the methods it may be desirable to alter and/or remove gallstones. Moreover, other obstructions within the biliary system can also be removed. The delivered conduit can be, for example, one or more of a stent, and a drug-coated stent. In some applications of the methods, biliary disease is treated without removal of the gallbladder. In still other applications of the method, a treatment area is visualized as part of the method. In some methods, the conduit is anchored in place. In still other methods, the conduit is changed from a delivery configuration to a deployment configuration, from a delivery configuration to a final configuration or from a deployment configuration to a final configuration. Still other methods provide for reducing a cross-sectional profile of the conduit, providing a seal to prevent fluid from leaking into a peritoneum, and/or restricting fluid flow from the gallbladder lumen to the gastrointestinal tract. Other methods include operating a valve to restrict fluid flow.

[0029] Still another aspect of the disclosure is directed to a conduit. The conduit can be formed such that it comprises: a shape memory wire configured for establishing fluid communication between a gallbladder and a target location within a gastrointestinal tract of a mammal, the shape memory wire being shaped to form a proximal end and a distal end with a lumen extending therethrough, a tubular section with a radially extending proximal flange and a radially extending distal flange. Thus, the conduit is formed from a bioresorbable material. Additionally, the conduit can be one or more of removable or expandable. Conduit configurations can be selected from a deployment configuration, a delivery configuration and a final configuration. Typically the conduit also comprises a variable profile and/or has a

cross-sectional area that is variable along its length. Moreover, the can be configured for deployment by at least one of an endoscope, a needle, a guidewire, a guidance catheter and a dilatation catheter. Additionally, the conduit can have a flareable end, be flexible, have an adjustable length, be at least partially from a shape memory material, be adapted and configured to engage a tubular valve member within a lumen, and/or have one or more retaining features adapted and configured to retain the conduit in situ, or any combination thereof.

**[0030]** In still other aspects, a conduit is provided that comprises: one or more rings at a proximal end and a distal end with adapted and configured to engage a compliant material forming a substantially tubular structure therethrough. The conduit can be formed from a bioresorbable material, can be configured to be flexible, removeable and/or expandable, to have one or more configurations selected from a deployment configuration, a delivery configuration and a final configuration, to have a variable profile and/or a cross-sectional area that is variable along a length, an adjustable length or combinations thereof. Additionally, the conduit can be configured for deployment by at least one of an endoscope, a needle, a guidewire, a guidance catheter and a dilatation catheter. The conduit can also be configured at least partially from a shape memory material. Additionally, one or more retaining features adapted and configured to retain the conduit in situ.

**[0031]** Yet other aspects of the disclosure include a delivery catheter comprising: delivery catheter comprising: a control handle, an elongate flexible shaft, a central rod, and a delivery element having a first conduit retaining component and a second conduit retaining element wherein a portion of a conduit is clamped between the retaining components during delivery, and released when the first retaining component is moved away from the second retaining component to release a conduit held on a distal end of the delivery catheter.

**[0032]** Still another delivery catheter comprises a control hand, an elongate flexible shaft, a central rod, and a at least one dilating electrosurgical electrode. At least one of a leading edge electrode can be provided and/or one or more radially arranged dilating electrodes. The dilating electrodes can be positionable to optimize a size of a resulting aperture.

**[0033]** A delivery catheter comprising a central member adapted and configured to move a distal end of the catheter relative to a coaxial sheath, further having one or more flexible members can also be provided. The flexible members can be configured to have one or more hinges adapted and configured to reduce strain. Moreover, the flexible hinges can expand outward to anchor and retain the delivery catheter within a lumen. Thus, for example, the

flexible members are configurable into an umbrella shape. The flexible members can further define a work space when opened.

[0034] A delivery catheter tool channel device can be provided that comprises a tubular structure adapted and configured to securely engage a distal end of a delivery catheter. The tool can further be configured to comprise a proximal end and a distal end with a central aperture adapted and configured to be positioned over the distal end of the delivery catheter. An elongate aperture positioned off center the elongated device can also be provided for receiving additional tools or components. In at least some configurations one or more apertures positioned through the main body of the tool is provided.

[0035] A delivery catheter tool channel device comprising a first component adapted and configured to securely fit within a channel of a delivery catheter, and a second component adapted and configured to provide an aperture through which a secondary device can be positioned wherein the first and second component are connected via a bridging mechanism can also be provided.

#### **INCORPORATION BY REFERENCE**

[0036] All publications, patents, and patent applications mentioned in this specification are herein incorporated by reference to the same extent as if each individual publication, patent, or patent application was specifically and individually indicated to be incorporated by reference.

#### **BRIEF DESCRIPTION OF THE DRAWINGS**

[0037] The novel features of the invention will be set forth with particularity in any claims presented based on this application. A better understanding of the features and advantages of the present invention will be obtained by reference to the following detailed description that sets forth illustrative embodiments, in which the principles of the invention are utilized, and the accompanying drawings of which:

[0038] **FIG. 1** illustrates an overview of the biliary system;

[0039] **FIG. 2** illustrates the biliary system with gallstones;

[0040] **FIG. 3** illustrates the distal end an endoscope positioned within a mammalian body accessing the biliary system via the intestinal system;

[0041] **FIG. 4** illustrates an embodiment of a device adapted to provide a conduit between two body lumens;

[0042] **FIGS. 5A-B** illustrates another embodiment of the device comprised of more than one material;

[0043] FIGS. 6A-D illustrates an embodiment of the device retained with suture or T-tags;

[0044] FIG. 7 illustrates another embodiment of the device comprised of bent wire;

[0045] FIG. 8 illustrates another embodiment of the device comprised of distal and proximal supporting rings and a connecting portion of thin flexible material;

[0046] FIG. 9 illustrates another embodiment of the device comprised of wire with a variety of cross sections forming a coil;

[0047] FIG. 10 illustrates an element that is insertable into the device adapted to provide a conduit between two body lumens;

[0048] FIGS. 11A-G illustrate a number of SMA retaining feature configurations for the device and a scheme of arranging them on the device;

[0049] FIG. 12A-E illustrate delivery of the device according to the invention via a catheter;

[0050] FIGS. 13A-B illustrate an embodiment of a delivery catheter for the device;

[0051] FIG. 14 illustrates another embodiment of a delivery catheter that incorporates electrosurgery electrodes;

[0052] FIGS. 15A-C illustrates another embodiment of a delivery catheter that incorporates a retaining and space-making element at the distal tip;

[0053] FIG. 16 illustrates an embodiment of a device that fits on the distal end of an endoscope that provides an additional tool channel or towing point;

[0054] FIG. 17 illustrates another embodiment of a device that fits on the distal end of an endoscope that provides an additional tool channel or towing point; and

[0055] FIG. 18 illustrates another embodiment of a device that fits on the distal end of an endoscope that provides an additional tool channel or towing point.

#### DETAILED DESCRIPTION OF THE INVENTION

[0056] Devices, systems, methods and kits provided herewith can obviate the need for a plurality of procedures, including, for example: 1) percutaneous cholecystostomy, 2) cholecystectomy, 3) percutaneous trans-hepatic cholangiography (PTHC), and 4) endoscopic retrograde cholangiopancreatography (ERCP). Additionally, disclosed treatment modalities enable treatment of a distal common bile duct *18* obstruction, *e.g.* secondary to pancreatic carcinoma, cholangiocarcinoma, and/or ampullary carcinoma. As will be appreciated by those skilled in the art, the conventional standard of care for treating biliary disease has been surgical removal of the gallbladder *14* and closure of the cystic duct *16*. While this has proven to be an effective mechanism for permanently eliminating biliary disease and its recurrence, the present invention seeks to accomplish the same end in a less invasive and less costly way. This may be achieved by treating biliary disease without requiring the removal

of the gallbladder **14**. Methods and apparatus are described in this application that are intended to effectively treat biliary disease with the gallbladder **14** and cystic duct **16** left *in situ* by providing a shunt to the gallbladder that enables fluid communication, or selective fluid communication, from the gallbladder, e.g., fluid can drain from the gallbladder into the small intestine via the shunt.

[0057] A method of treating biliary disease involves using an endoscope **310** to access a region **350** in the gastrointestinal (GI) tract (**FIG. 3**) to which the gallbladder **14** is in close proximity, locating the gallbladder **14**, accessing the gallbladder, and then treating the underlying condition that led to the need for intervention. As will be appreciated by those skilled in the art, as a result of variations in anatomy, the actual location of the target region. Treatments may also include, but are not limited to: providing for drainage of the gallbladder **14** and/or the biliary tree, delivering suitable materials or substances, such as antibiotics, inflammatory, anti-inflammatory agents (any of which may be short-term acting, fast acting, or time release), and/or other substances (*e.g.* adhesives, bioadhesives, *etc.*) to the gallbladder **14** and/or biliary tree, removing gallstones **20**, facilitating the destruction and subsequent removal of gallstones, clearing obstructions, delivering catheters, delivering stents (drug coated or not drug coated), temporarily or permanently defunctionalizing the cystic duct **16**, temporarily or permanently defunctionalizing the gallbladder **14**. Devices and therapies can be delivered in a single treatment, with minimal likelihood of or necessity for follow-up or repeat procedures.

[0058] The gallbladder can be accessed by any suitable mechanism or procedure including, percutaneously, endoscopically, laparoscopically, and the like. Moreover, any of the materials and substances delivered to the gallbladder can be delivered concurrently or sequentially. Delivery of substances can occur sequentially in time or the sequence of delivery can be separated by seconds, minutes, or hours.

[0059] Localization of the gallbladder **14** can be performed via endoscopic ultrasound (EUS) by accessing the wall of the GI tract with an endoscope **310** as shown in **FIG. 3**. Localization may also be achieved by any other method that visualizes anatomical features, such as fluoroscopy, x-rays, magnetic resonance imaging (MRI), computed axial tomography (CT) scans, ultrasound imaging from outside the body, or any method of anatomical imaging and visualization.

[0060] Once the gallbladder **14** has been located, it may be accessed and/or treated at the target region or site **350** through the wall of the GI tract (or any lumen in proximity to the gallbladder **14**) with tools and devices (*e.g.* needles, guidewires, guidance catheters, dilators,

*etc.*) delivered through, for example, an endoscope **310**. Such tools and devices may be inserted down the length of the endoscope's working channel **312**, or loaded onto or near the distal end of the endoscope **310**. Alternately, tools and other devices may be used that do not require the aid of the endoscope for navigation or delivery. Direct visualization may be provided by the endoscope **310** during the procedure, as well as irrigation, suction, and insufflation.

[0061] Though the preferred location for accessing the gallbladder lumen is the duodenum **30**, it may also be readily achieved through the wall of other regions of the GI tract, such as the stomach or the jejunum, for example. Thus, any lumen in close proximity to the gallbladder **14** is a candidate for access to and treatment of the gallbladder **14** and other members of the biliary system.

**DESCRIPTION OF THE DEVICES:**

[0062] In the present invention, *in situ* treatment of the gallbladder **14** is enabled via the creation of a passageway between the gallbladder lumen and a lumen in close proximity, *e.g.* at or near the duodenum. This passageway or duct may be created by an implantable device **420**, such as that illustrated in **FIG. 4**.

[0063] The passageway may be temporary or permanent. It may be thought of as a fistula that is intentionally created between the gallbladder **14** and another lumen in proximity to the gallbladder, as described above. Alternately, it may be thought of as a stoma between the gallbladder **14** and another lumen in proximity. The passageway serves as a conduit, an access port, through which a number of actions may be accomplished, drainage may be achieved, and treatments may be delivered.

[0064] A device **420** forming the passageway may be left in the patient for a short period of time, such as a few hours, a few days or a few weeks, or it may be left in place for extended periods of time, such as several weeks, months, or years. The device **420** may also be left in place permanently. If it is left in place long-term, tissue may form around the device **420**, creating a fistula that connects the gallbladder **14** to the access lumen which may persist even if the passageway device **420** is removed, thus forming a biological *in situ* device **420** from the patient's own tissue. The fistula may be beneficial and useful, as it may continue to allow drainage for the contents of the gallbladder **14** into the small intestine. It may provide either the primary or a secondary mechanism for delivering bile into the digestive system, for example. It may also provide convenient access in cases where repeated treatments are required. Though there may be no need to close the resulting fistula, it may also be closed at any time by a clinician should this become desirable. After removal of a device **420** that

initially formed the passageway, a fistula may remain open for a period of time and then close on its own, and may pose no additional risk and prove to be an acceptable course of events. Whether the device **420** is left in place or removed, and whether the fistula is left open or closed, evidence at the site may serve to mark the location of treatment in the event of future procedures.

[0065] To facilitate delivery and deployment of a device **420**, it may be useful to reconfigure its shape. For example, the cross-sectional area presented by the device **420** at various locations may be reduced, thus, for example, reducing its overall profile. In cases where the configuration of the device **420** is caused to change, it may be helpful to conceive of the device **420** having one or more configurations, for example: one configuration when it is delivered (a "delivery configuration"), another configuration when it is deployed (a "deployment configuration"), and yet another configuration when it is in place and functional (a "final configuration" or "functional configuration"). Still other configurations may also be necessary or useful. For the delivery configuration, it may be advantageous to alter (*e.g.* reduce) the cross-sectional area or profile, so that it more easily fits delivery mechanisms, such as the working channel of an endoscope **310** (illustrated in **FIG. 3**). During deployment, the configuration of the device **420** may be altered so that placement into the patient is facilitated. This may be different from both the delivery configuration and the final configuration, though this is not necessarily the case. As will be appreciated by those skilled in the art, one or more configurations can be the same or substantially the same.

**DESCRIPTION OF THE CONDUIT:**

[0066] The preferred embodiment of the conduit is that of a short tube that has flared tissue retention features at both ends, as depicted in **FIG. 4**, which secure the conduit device **420** in the desired location within the gallbladder **14** and the access lumen, *e.g.* the duodenum **30**. The conduit **420** forms the proposed passageway **424** between the gallbladder **14** and the body lumen from which it will be accessed, such as through the duodenum **30** (**FIG. 2**). A tubular portion **430** (**FIG. 4**) of the conduit **420** is typically about 4-10 mm in length **h1**, with a first diameter **w1** of the device large enough to facilitate drainage and access, typically in the range of 2-10 mm. However, other dimensions can be used without departing from the scope of the invention. A second diameter **w2** of the tubular portion **430** of the conduit **420** is typically larger than about 3 mm (10 French) in its final configuration. The device has an inner diameter **w3** which defines a lumen or passageway **424** through the device from a first end **421** to a second end **423**. The passageway **424** enables fluid communication from one end of the device to the other end of the device. The shape of the retention features may be

the same on both ends, or they may be different on either end, as is shown in **FIG. 4**, where the distal end **422** is divided into at least one finger so that it resembles a star shape and the proximal end **425** is substantially a flat disc-like element with gentle curved features at the edges so that the device is atraumatic to adjacent tissue. Dividing a retaining feature into at least one finger facilitates folding the features forward or backward so that the profile of the device may be reduced for delivery. The conduit may be constructed from any suitable material (e.g. silicone, urethane, polyurethane, Teflon, TFE, PTFE, ePTFE, Nitinol, stainless steel, etc.), however a soft durometer molded silicone material is preferred in this embodiment.

**[0067]** Another embodiment, shown in **FIGS. 5A-B** in a section view and a top view, is a multi-component assembly comprised of more than one material. In the embodiment shown, a soft pliable material (e.g. a low durometer silicone) comprises a tubular portion **530** of the conduit, and is attached to a dissimilar material which forms the flared retaining feature **534**, **534'** at either the distal end **522**, the proximal end **524**, or both ends. The materials may be attached by any suitable mechanisms, elements, means or design features that secure the ends together. Alternatively, other materials may be used to attach them such as adhesives, clips, clamps, or other hardware components.

**[0068]** A variation on any embodiment of conduit comprised of any material involves the use of additional elements to secure the device in place relative to the tissue **657** adjacent to the device **620** and distribute any forces or physical loading of the device and tissue to prevent pull-through, dislodgement or migration of the device as shown in **FIGS. 6A-D**. This may be done using a suitable material, such as suture **691** (as illustrated in **FIG. 6A**) or T-tags **692** (**FIG. 6C**). The retaining and load-distributing material may be caused to go through holes or apertures **634** in the conduit retaining flanges, projecting rim, collar, or ring at the distal end **622** and/or the proximal end **625**, and these holes or apertures may either be created when the retaining and load-distributing material (e.g. suture) is applied or they may be integrally designed into and manufactured as a feature of the device. Alternately, the retaining and load-distributing material (e.g. suture) may be arranged so that it encircles, captures or otherwise retains elements of the conduit.

**[0069]** Another embodiment of the conduit made from an elastic material in wireform. The wireform can be formed from a suitable shape memory elastic material such as nickel titanium alloy, also known as nitinol. The wire is configured or trained to assume the general shape of conduit as described throughout this specification, with a zig-zag pattern that runs in the longitudinal direction (end-to-end), as shown in **FIG. 7**. For delivery, the wire may be

compressed, straightened, or otherwise reduced in overall size. In the deployed or final configuration, this embodiment incorporates at least a distal end **722** retaining feature having two or more radial projections extending from a central axis that runs along the length of the device (e.g., through a passageway, if a passageway is present), a proximal end **725** retaining feature having two or more radial projections, and a tubular portion **730**.

[0070] Yet another embodiment of a distal or proximal retaining feature for the conduit is shown in **FIG. 8**, and is comprised of a ring (or other shape that fully or partially encloses an area) of material **893** that may be constrained into a smaller profile for delivery, and that has a larger shape when not constrained. The material may be metallic, such as Nitinol, stainless steel or spring steel, or it may be elastomeric or plastic, such as silicone, urethane, etc. A ring **893, 893'** may be positioned at the proximal end **802** of the device **820**, the distal end **804** of the device **820**, or both the proximal and distal ends. Attached to the ring is a compliant material **894** such as ePTFE or biocompatible fabric, sheet, or film, which comprises the tubular portion of a conduit, **830**, and creates a lumen, aperture or passageway **824** therethrough.

[0071] **FIG. 9** illustrates another embodiment of a conduit device, in which a coil is made of material with sufficient elasticity to allow it to be elongated into a straight wire without causing plastic deformation. Suitable materials include shape memory alloys, such as Nitinol, or other suitable shape memory materials. When not constrained and allowed to relax, the wire assumes the general shape of the conduit **920**, and is comprised entirely of loops of coiled wire. The profile of the wire may be round, square, triangular, trapezoidal, polygonal, or any other profile shape which wire can be configured to have. In the case of a round profile, the wire is most easily manufacturable and obtainable. In the case of a square profile, the successive turns of the coil that together comprise the conduit may slide linearly relative to a neighboring turn of coil without opening a space through which material (e.g. bile, chyme) may flow. The device comprises a distal end having a radially extending section at a distal end and a proximal end with a neck therebetween having a radius less than the radius of one or both of the radially extending sections. Moreover, a passageway can be provided to provide fluid communication between the distal end and the proximal end.

[0072] Various embodiments may benefit from the insertion of an element **1051** into their inner lumen, aperture or passageway **1024**, such as is illustrated in **FIG. 10**. The element may optionally include a feature that acts as a valve (e.g. a flap-, duckbill-, bicuspid-, tricuspid-, n-cuspid-, ball-, or other valve configuration) to control the flow of material between the gallbladder and the GI tract (e.g. a one-way valve, check valve, or a standard valve). The

inserted element may serve to provide rigidity and/or support for the tubular portion **1030** so that its shape or configuration does not change in an undesirable way over the useful life of the device. The element may also serve to secure the conduit into position relative to the adjacent tissue, for example by expanding the device outward or otherwise increasing its outer dimensions, or alternately by incorporating a feature that otherwise serves to anchor or retain the inserted element (e.g. o-ring grooves, ridges, teeth, bumps, etc.). In cases where the inserted element provides structural integrity or support, the lumen or passageway **1024** of the conduit may entirely or partially lack structural integrity of its own and rely entirely on the inserted element to maintain a communication between the gallbladder and the GI tract (e.g. as shown in **FIG. 8**). In such cases, the element comprising the tubular portion of a conduit may be a sheath, flat tube/sleeve, balloon (inflated or deflated), coil, or any other shape into which the element may be inserted. Optionally, the inserted element and the tubular element may be secured together by an additional retaining element **1036**, such as an elastic band, an o-ring, or an adhesive.

**[0073]** **FIGS. 11A-G** illustrates a number of embodiments of the conduit's retaining features **1122** located at either end of the conduit, which may be comprised of shape memory material (e.g. Nitinol) or other suitable elastic or superelastic material. This may be the case whether the tubular portion **1130** of the conduit **1120** is formed from the same or from different materials. Such retaining features may take on a number of shapes and configurations. **FIGS. 11A** through **F** show several of the many possible embodiments, in which the retaining features **1122** resemble fingers (e.g. elongate extensions). **FIGS 11G** shows how the fingers may be arranged in a radial star- or asterisk-like pattern from the ends of the conduit's tubular portion **1130**. During delivery, the fingers are flexed in towards the central axis  $x$  of the tube **1130** to reduce the profile. Upon deployment, the fingers are allowed to spread outwards to function as retaining features. If such retaining features are incorporated on both ends of the tubular portion, the arrangements on either end may be rotated relative to each other to avoid pinching tissue held between them for the benefit of reducing the loading imparted to the tissue and reducing the potential for tissue necroses. This is illustrated in **FIG. 11G**, which shows a case where each end of the tube **1130** has four such retaining fingers, and the retaining fingers at the distal end are rotated 45 degrees relative to the retaining fingers at the proximal end of the tubular portion of the conduit. The number of degrees of rotation depends on the number of retaining features at either end, and may have either equal spacing (as illustrated in **FIG. 11G**) or variable spacing.

[0074] The conduit may be made of any suitable biocompatible material that is elastic and soft. Silicone is the preferred material. Other materials may optionally be used, *e.g.* polytetrafluoroethylene (PTFE), expanded PTFE, other members of the fluoropolymer family, urethanes, polyurethanes, and others. The materials can, for example, be soft at body temperature, with durometer typically in the range of 20-90 A. Softer materials are easier to deliver and reduce the risk of injury to adjacent tissue. A suitable material is, for example, soft enough to compress to a compact size for delivery and deployment.

[0075] Embodiments of retaining features may be comprised of compliant polymeric material (*e.g.* silicone). If they are comprised of soft, compliant materials, the retaining features can readily bend and deform to accommodate the passage of large items through the conduit formed between a first body lumen and a second body lumen, *e.g.* the gallbladder and the duodenum. Alternately, the retaining features may be formed from less compliant material or a metal (*e.g.* Nitinol or stainless steel). The retaining features may be formed integrally with other elements of the overall conduit device, such that the components are formed to act in a unified manner as a single component, or may be separate from the other elements of the overall conduit device. The retaining features may be incorporated into the overall assembly during manufacturing, or the parts may be installed by a clinician user prior to use in a patient or during deployment of the device within a patient.

[0076] The device, or other devices described herein, may also be comprised of a biodegradable, bioabsorbable, or resorbable material, in which case it may dissolve within the mammalian body within a desirable and useful length of time. This could eliminate the need for follow-up procedures to remove the device at the end of a course of treatment. Manufacturing the device from such a material may not prevent clinicians from actively removing it if the need arose, however. Rather, it would prevent the need to actively remove it in cases where no other treatment was required.

[0077] The conduit may be comprised of a single component and a single material, or it may be an assembly of different components, some of which may be of different materials that are integrally formed to act or perform in a unified manner once deployed. For instance, a conduit may be comprised of an SMA spring form, over which silicone (or another suitable polymer material) is molded. The spring form serves to lend the conduit structure and dimensional stability, while the silicone (or other polymer) outer shell creates soft surfaces which are unlikely to cause injury to tissue and facilitate sealing of the device *in situ* and prevent leaks. If SMA materials are used, their transition temperatures can be selected to be slightly below body temperature, so that they can be designed to hold one shape for delivery

and deployment, and, after transitioning, they will have the desired shape(s) for optimizing the function of the conduit. Alternately, the SMA material may be used in its superelastic state.

**DESCRIPTION OF THE DELIVERY MECHANISMS:**

[0078] Delivery of the conduit may be accomplished in a variety of ways.

[0079] An exemplar delivery method is shown in FIG. 12. The exemplar delivery method shown in FIGS. 12A through E involves using an endoscope 1210 to place one or more guidance elements 1280 (for example a needle, a guidewire, and/or a guidance catheter) between the access body lumen (*e.g.* the duodenum, stomach, or jejunum) and the gallbladder 14. In cases where a needle, a guidewire and/or a guidance catheter are used, a guidance catheter may be advanced in the patient's gastrointestinal tract at a target region or location, often but not necessarily within the working channel 1212 of an endoscope 1210, until the distal tip of the guiding catheter is proximal to the desired placement location for the device 1220. A needle may be advanced out of the distal end of the guiding catheter through the wall in the gastrointestinal tract, *e.g.* at a duodenum 30, continuing through the wall of the gallbladder 14, and into the lumen of the gallbladder. As an optional step, bile may be aspirated through the needle or any other guidance element 1280 to reduce the pressure within the gallbladder 14, reducing the risk of bile escaping the gallbladder within the peritoneum. To facilitate this, the guidance element (*e.g.* needle, guidewire, guidance catheter) may incorporate an aspiration port 1286, either distal or anywhere along a surface or wall. As another optional step, a guidewire may be inserted into the gallbladder lumen through the needle. In cases where a guidewire is used, the needle may be withdrawn once the guidewire has been inserted. When desirable, either the guidance catheter or a separate dilatation catheter, having an inflatable balloon, mechanical tissue expander, or other means of dilation on the distal portion thereof, may be advanced over the previously introduced needle or guidewire until the dilation element is properly positioned through the wall of the gastrointestinal tract and the wall of the gallbladder 14. Once in the desired position, the dilatation catheter may dilate the tissue around the catheter so that it is expanded to accommodate the device 1220. Generally, the diameter of the dilated puncture in the wall of the gallbladder 14 and gastrointestinal tract access lumen is slightly smaller than the outer diameter of the tubular portion 1230 of the device 1220 that will be inserted through the puncture. In one approach, the device 1220 may then be guided into position over the guidance element(s) 1280 (*e.g.* needle, guidewire, guidance catheter, delivery catheter) through the hole in the wall of the gastrointestinal tract and the wall of the gallbladder 14 to

the desired depth. Once in the desired position, the device *1220* may be deployed and held in position by its retaining features *1222* and the adjacent tissue.

[0080] A delivery catheter for the conduit may be configured in a variety of ways. Persons of skill in the art will be familiar with the details of catheter construction, including variations of the proximal end and shaft region. See, for example, the following references:

**PAT. NO. Title**

---

7,727,225	Coaxial catheter systems for transference of medium
7,722,629	System and method for catheter-based septal defect repair
7,717,936	Device for loading an embolic protection filter into a catheter
7,717,871	System and method for site specific therapy
7,704,245	Large diameter delivery catheter/sheath
7,704,223	System and method for delivering a substance to a body cavity
7,670,364	Stent delivery system having stent securement apparatus
7,647,891	Method and apparatus for creating a pathway in an animal
7,645,259	Multi-function catheter and use thereof
7,641,645	Combination thrombolytic infusion catheter and dilator system
7,634,319	Method and anchor for medical implant placement, and method of anchor manufacture

[0081] For purposes of appreciating this disclosure, an exemplar delivery catheter is illustrated in **FIG. 13A**, which shows a view of the entire delivery catheter system, which incorporates a control handle at the proximal end *1302*, an elongate flexible shaft *1363* (the length of which is adequate for reaching the desired site in the access lumen, and may be longer or shorter than depicted herein) and a delivery element *1364* at the distal end *1304*. The disclosure, however, focuses on details relating to the distal end. The proximal end control handle *1361* incorporates a pushable button element *1362* which moves a central pushrod *1368* relative to the control handle grip *1369* and the elongate shaft *1363* to actuate movable components incorporated in the delivery element *1364* at the distal end *1304*. The delivery element incorporates two cone-shaped components, an inner cone *1365* and an outer cone *1366*. Pushing the button *1362* in the handle *1361* pushes the outer cone *1366* forward and away from the inner cone *1365*. The distal-most cone clamps the distal flange of the conduit (bending it forward and reducing its profile) against the proximal-most cone. Pushing the distal-most cone forward releases and unfurls the distal-most flange of the

conduit (once it's been inserted through the walls and is where we want it to be deployed). A conduit *1320* is loaded onto the delivery element *1364* of the delivery catheter *1353*, where the inner cone *1365* and outer cone *1366* clamp together over and secure the flared retaining features *1322* at the conduit's distal end. The configuration of the cones *1365* and *1366* also serve to position the distal flared retaining features *1322* forward and inward to reduce their profile and facilitate delivery to the implantation site, while the cone shape facilitates insertion in to the hole created between the gallbladder *14* and the access lumen in the GI tract. When the conduit has been inserted into the hole and is in the desired location, the delivery element *1364* may be actuated by pushing on the button *1362* in the handle *1361*, which separates the cones *1365* and *1366* and deploys the distal retaining features *1322* of the conduit *1320*. This is illustrated in **FIG. 13B**. With the distal retaining features *1322* holding the device securely in place, the proximal retaining feature *1322* retains the device in the access lumen (e.g. duodenum, stomach, or jejunum), and the delivery catheter *1353* may be withdrawn.

[0082] Another embodiment of a delivery catheter is shown in **FIG. 14**. At the distal end of the delivery element *1402* this embodiment incorporates at least one electro-surgical electrode *1470* so that the hole in the wall of the access lumen (e.g. duodenum, stomach, jejunum, etc.) and gallbladder wall may be created and sized with the same instrument that delivers and deploys a conduit *1420*. More than one electro-surgical electrode may be incorporated in the distal end of the delivery catheter, and may include a leading edge electrode *1471* and one or more radially arranged dilating electrodes *1472*. The dilating electrodes may be configured to be positionable by the clinician (for example, by pushing or pulling the button *1462* at the handle *1461*), so that the size of the resulting hole is selectable. Deployment of the conduit *1420* may then be performed using any suitable means and actions with the delivery element *1464*.

[0083] Another embodiment of delivery catheter is shown in **FIG. 15**. In this embodiment, the distal end *1504* is configured in such a way that pulling back on a central member (e.g. a pull cable or wire) *1573* moves the distal end of the device *1504* relative to a coaxial sheath *1574*. Attached to the coaxial sheath and the central member is one or more flexible members *1575*, made from an elastic or superelastic material such as Nitinol, or alternately mechanically hinged so that large mechanical strain is not created. When the sheath *1574* and the central member *1573* are moved relative to each other, the flexible members *1575* expand outward, which can be used to anchor and retain the delivery catheter within a lumen, create a working volume within the gallbladder, and enable clinicians to pull back on the

catheter to hold the wall of the gallbladder *14* and the access lumen (such as the duodenum, stomach, jejunum, etc.) in apposition. Further, if the flexible members *1575* may be configured so that further retracting the central member *1573* causes the flexible members *1575* to double back and create an umbrella shape, which may then define a volume within which manipulations may be performed (a “work space”), such as deploying a conduit. Optionally, the flexible members may incorporate electrosurgical electrodes *1576* for cutting and dilating a hole into a desired configuration.

[0084] FIG. 16 shows a device *1677* which may facilitate delivery by an endoscope *1610* of elements that are ill suited for delivery through the endoscope’s tool channel *1612*, or when a tool channel is otherwise occupied. This may be thought of as an adjunct tool channel, or in some cases, a towing point or “hitch”, by means of which elements may be brought to a site by an endoscope and used without requiring repeated insertion and withdrawal of the endoscope or tools within the working channel of the endoscope. The device *1677* may be added at the distal end of the endoscope *1610* by means of clipping, bonding, or otherwise attaching, but preferably without or with only minimal modifications to the endoscope itself. The shape of the device is smooth in order to reduce or eliminate trauma to any tissue it contacts, and to reduce the likelihood of pinching or catching tissue. The device *1677* optionally incorporates at least one “hitching point” or auxiliary tool channel outlet *1678*, to which elements (e.g. tubes, wires, catheters, etc.) may be attached and the distal end controlled with the bending section of the endoscope or with features incorporated into the elements, in much the same fashion that the position of tools are controlled when inserted into the endoscope’s primary tool channel.

[0085] Another embodiment of the device *1779* is shown in FIG. 17. This device is affixed to the distal tip of an endoscope *1710* at the distal outlet of the tool channel *1712*. The device is configured as a thin ring, which is inserted partially or entirely into the outlet of the tool channel *1712* in order to retain and secure the device during a procedure. The device optionally incorporates at least one hitching point or auxiliary tool channel outlet *1778* on a member or stem *1781* that extends outward beyond the outer rim of the endoscope’s distal tip. Elements such as tubes, wires, catheters, etc. may be attached to the hitching point or tool channel outlet, as described above.

[0086] Yet another embodiment of the device is shown in FIG. 18. In this embodiment, the device *1879* is configured as a cap that fits over the distal end of an endoscope *1810*, with at least one hole in the portion covering the endoscope’s distal end to accommodate the function of the endoscope’s integral camera, illumination, tool channel, irrigation, aspiration, etc. The

device *1879* attaches temporarily or permanently to the distal end of the endoscope *1810*, and optionally incorporates at least one hitching point or auxiliary tool channel outlet *1878* at the perimeter. Elements such as tubes, wires, catheters, etc. may be attached to the hitching point(s) or tool channel outlet(s), as described above.

**DESCRIPTION OF OTHER USES:**

[0087] The techniques and devices described in this application may prove beneficial in applications beyond their initial use in the treatment of biliary disease.

[0088] For example, they may prove to be an effective mechanism of treating cholangitis (infection of the common bile duct *18*). This condition is usually bacterial, and occurs when the bile duct is blocked by gallstones *20* or a tumor. Traditional treatment involves the insertion a stent or drainage catheter into the common bile duct *18* to allow bile to drain into the duodenum from locations above the obstruction. Placement of a conduit into the gallbladder *14* may allow for an alternate method of draining bile and/or other fluids into the duodenum. Any blockage in the common bile duct *18* between the entrance of the cystic duct and the duodenum may be treated in this way. See FIG. 2.

[0089] Another use of the devices and techniques described elsewhere in this application may be to create anastomoses between any body lumens in proximity to one another. This may include, but is not limited to: small bowel to small bowel anastomoses, small bowel to large bowel anastomoses, large bowel to large bowel anastomoses, and stomach to small bowel anastomoses. Additionally, creating a conduit between lumens within the GI system, such as between the stomach and other body lumens, esophagus and other body lumens, duodenum and other body lumens, etc., may be useful and effective for treating and/or managing obesity.

[0090] Another use of the devices and techniques described herein is for drainage of any body lumen into another body lumen in proximity, for example, the drainage of pancreatic pseudocysts.

**KITS:**

[0091] The devices disclosed herein can be provided within suitable packaging in kit form as will be appreciated by those skilled in the art. The kits can include one or more devices, one or more components useful for delivering the devices, and one or more pharmacological agents useful in performing the operation to deliver the device or devices.

[0092] While preferred embodiments of the present invention have been shown and described herein, it will be obvious to those skilled in the art that such embodiments are provided by way of example only. Numerous variations, changes, and substitutions will now

occur to those skilled in the art without departing from the invention. It should be understood that various alternatives to the embodiments of the invention described herein may be employed in practicing the invention. It is intended that the following claims define the scope of the invention and that methods and structures within the scope of these claims and their equivalents be covered thereby.

## CLAIMS

### WHAT IS CLAIMED:

1. A device for treating biliary disease comprising:  
a component configured for establishing fluid communication between a gallbladder and a target location within a gastrointestinal tract of a mammal, the component having a proximal end and a distal end with a lumen extending therethrough, a tubular section with a radially extending proximal flange and a radially extending distal flange wherein at least one of the proximal flange and distal flange is disc shaped and at least one of the proximal flange and the distal flange has a plurality of radially extending elements.
2. The device of claim 1 wherein the device is formed from a bioresorbable material.
3. The device of claim 1 wherein the device is removable.
4. The device of claim 1 wherein the device is expandable.
5. The device of claim 1 further comprising one or more configurations selected from a deployment configuration, a delivery configuration and a final configuration.
6. The device of claim 5 further comprising a variable profile.
7. The device of claim 1 wherein a cross-sectional area of the device is variable along a length.
8. The device of claim 1 wherein the device is configured for deployment by at least one of an endoscope, a needle, a guidewire, a guidance catheter and a dilatation catheter.
9. The device of claim 1 further comprising a flareable end.
10. The device of claim 1 wherein the component has one or more clips configured to secure the component at one or more positions.
11. The device of claim 1 further comprising one or more fenestrations.
12. The device of claim 1 wherein the device is flexible.
13. The device of claim 1 wherein the tube has an adjustable length.

14. The device of claim **1** wherein the device is configured at least partially from a shape memory material.
15. The device of claim **1** wherein the device is configured from one or more wires.
16. The device of claim **1** wherein the device is adapted and configured to engage a tubular valve member within the lumen.
17. The device of claim **1** further comprising one or more retaining features adapted and configured to retain the device in situ.
18. The device of claim **1** wherein at least one of the distal flange and proximal flange extend perpendicularly from the tubular section.
19. The device of claim **1** wherein at least one of the distal flange and proximal flange extend from the tubular section and curve back toward the tubular section.
20. A biliary disease treatment device comprising:  
a component configured for establishing fluid communication between a gallbladder and a target location within a gastrointestinal tract of a mammal, the component having a proximal end and a distal end with a lumen extending therethrough, a tubular section with a radially extending proximal flange and a radially extending distal flange adapted to be delivered by an endoscope to a gastrointestinal site in proximity to a gallbladder.
21. The device of claim **20** wherein a conduit is formed between a gallbladder lumen and a target location within the gastrointestinal tract.
22. The device of claim **21** wherein the target location within the gastrointestinal tract is proximal to a duodenum.
23. The device of claim **20** wherein the device is formed from a bioresorbable material.
24. The device of claim **20** wherein the device is removable.
25. The device of claim **20** wherein the device is expandable.

26. The device of claim **20** further wherein the device is configurable in one or more configurations selected from a deployment configuration, a delivery configuration and a final configuration.
27. The device of claim **26** further comprising a variable profile.
28. The device of claim **20** wherein a cross-sectional area of the device is variable along a length.
29. The device of claim **20** further comprising a flareable end.
30. The device of claim **20** wherein the device is flexible.
31. The device of claim **20** wherein the device is configured at least partially from a shape memory material.
32. The device of claim **20** wherein the device is configured from one or more wires.
33. The device of claim **20** wherein the device is adapted and configured to engage a tubular valve member within the lumen.
34. The device of claim **20** further comprising one or more retaining features adapted and configured to retain the device in situ.
35. A method of delivering a device to treat biliary disease comprising:
  - a. using an endoscope to place at least one of a guidewire, a needle, a guidance catheter, and a dilatation catheter between an access lumen in a body and a gallbladder;
  - b. inserting a delivery catheter over the at least one of guidewire, needle, guidance catheter, and dilatation catheter and into the gallbladder;
  - c. delivering a component configured for establishing fluid communication between a gallbladder and a target location within a gastrointestinal tract of a mammal, the component having a proximal end and a distal end with a lumen extending therethrough, a tubular section with a radially extending proximal flange and a radially extending distal flange wherein at least one of the proximal flange and distal flange is disc shaped and at least one of

the proximal flange and the distal flange has a plurality of radially extending elements; and

- d. positioning the component between the access lumen in the body and the gallbladder to create a lumen therebetween.

36. The method of claim **35** further comprising the step of passively retaining a distal end of the guidewire in the gallbladder while the guidewire is used to deliver additional elements.

37. The method of claim **35** further comprising the step of retaining a distal end of the guidewire within the gallbladder.

38. The method of claim **35** further comprising the step of removing gallstones through the created lumen.

39. The method of claim **35** further comprising the step of delivering a substance to the gallbladder via the created lumen.

40. The method of claim **39** wherein the substance occupies the gallbladder lumen.

41. The method of claim **35** wherein the substances are one or more of antibiotics, inflammatory agents, and anti-inflammatory agents.

42. The method of claim **35** further comprising the step of preventing bile from entering a gallbladder lumen.

43. The method of claim **35** further comprising the step of localizing the gallbladder via endoscopic ultrasound.

44. The method of claim **35** further comprising the step of accessing the gallbladder via the gastrointestinal tract.

45. The method of claim **44** wherein the step of accessing is performed in the gastrointestinal tract at a duodenum.

46. The method of claim **35** further comprising the step of removing gallstones.

47. The method of claim **35** further comprising the step of altering gallstones.

48. The method of claim **47** further comprising the step of removing the altered gallstones.
49. The method of claim **35** further comprising the step of clearing obstructions within the gallbladder.
50. The method of claim **35** wherein the biliary disease is treated without removal of the gallbladder.
51. The method of claim **35** further comprising the step of visualizing a treatment area.
52. The method of claim **35** further comprising the step of anchoring the component in place.
53. The method of claim **35** further comprising the step of changing the component from a delivery configuration to a deployment configuration.
54. The method of claim **35** further comprising the step of changing the component from a delivery configuration to a final configuration.
55. The method of claim **35** further comprising the step of changing the component from a deployment configuration to a final configuration.
56. The method of claim **35** further comprising the step of reducing a cross-sectional profile of the component .
57. A conduit comprising: a shape memory wire configured for establishing fluid communication between a gallbladder and a target location within a gastrointestinal tract of a mammal, the shape memory wire being shaped to form a proximal end and a distal end with a lumen extending therethrough, a tubular section with a radially extending proximal flange and a radially extending distal flange.
58. The conduit of claim **57** wherein the conduit is formed from a bioresorbable material.
59. The conduit of claim **57** wherein the conduit is removable.
60. The conduit of claim **57** wherein the conduit is expandable.

61. The conduit of claim **57** further comprising one or more configurations selected from a deployment configuration, a delivery configuration and a final configuration.

62. The conduit of claim **61** further comprising a variable profile.

63. The conduit of claim **57** wherein a cross-sectional area of the conduit is variable along a length.

64. The conduit of claim **57** wherein the conduit is configured for deployment by at least one of an endoscope, a needle, a guidewire, a guidance catheter and a dilatation catheter.

65. The conduit of claim **57** further comprising a flareable end.

66. The conduit of claim **57** wherein the conduit is flexible.

67. The conduit of claim **57** wherein the tube has an adjustable length.

68. The conduit of claim **57** wherein the conduit is configured at least partially from a shape memory material.

69. The conduit of claim **57** wherein the conduit is adapted and configured to engage a tubular valve member within a lumen.

70. The conduit of claim **57** further comprising one or more retaining features adapted and configured to retain the conduit in situ.

71. A conduit comprising: one or more rings at a proximal end and a distal end with adapted and configured to engage a compliant material forming a substantially tubular structure therethrough.

72. The conduit of claim **71** wherein the conduit is formed from a bioresorbable material.

73. The conduit of claim **71** wherein the conduit is removable.

74. The conduit of claim **71** wherein the conduit is expandable.

75. The conduit of claim **71** further comprising one or more configurations selected from a deployment configuration, a delivery configuration and a final configuration.

76. The conduit of claim **75** further comprising a variable profile.
77. The conduit of claim **71** wherein a cross-sectional area of the conduit is variable along a length.
78. The conduit of claim **71** wherein the conduit is configured for deployment by at least one of an endoscope, a needle, a guidewire, a guidance catheter and a dilatation catheter.
79. The conduit of claim **71** wherein the conduit is flexible.
80. The conduit of claim **17** wherein the tube has an adjustable length.
81. The conduit of claim **71** wherein the conduit is configured at least partially from a shape memory material.
82. The conduit of claim **71** further comprising one or more retaining features adapted and configured to retain the conduit in situ.
83. A delivery catheter comprising: a control handle, an elongate flexible shaft, a central rod, and a delivery element having a first conduit retaining component and a second conduit retaining element wherein a portion of a conduit is clamped between the retaining components during delivery, and released when the first retaining component is moved away from the second retaining component to release a conduit held on a distal end of the delivery catheter.
84. A delivery catheter comprising: a control handle, an elongate flexible shaft, a central rod, and a at least one dilating electrosurgical electrode.
85. The delivery catheter of claim **83** further comprising a leading edge electrode.
86. The delivery catheter of claim **83** further comprising one or more radially arranged dilating electrodes.
87. The delivery catheter of claim **83** wherein the dilating electrodes are positionable to optimize a size of a resulting aperture.

88. A delivery catheter comprising a central member adapted and configured to move a distal end of the catheter relative to a coaxial sheath; and one or more flexible members.
89. The delivery catheter of claim **88** wherein the flexible members have one or more hinges adapted and configured to reduce strain.
90. The delivery catheter of claim **88** wherein the flexible members are adapted and configured to expand outward to anchor and retain the delivery catheter within a lumen.
91. The delivery catheter of claim **88** wherein the flexible members are configurable into an umbrella shape.
92. The delivery catheter of claim **91** wherein the flexible members define a work space.
93. A delivery catheter tool channel device comprising a tubular structure adapted and configured to securely engage a distal end of a delivery catheter wherein the device is adapted and configured to provide at least one additional tool channel.
94. The delivery catheter tool channel device of claim **93** further comprising a proximal end and a distal end with a central aperture adapted and configured to be positioned over the distal end of the delivery catheter.
95. The delivery catheter tool channel device of claim **93** further comprising an elongate aperture positioned off center the elongated device.
96. The delivery catheter tool channel device of claim **93** further comprising one or more apertures positioned therethrough.
97. A delivery catheter tool channel device comprising a first component adapted and configured to securely fit within a channel of a delivery catheter, and a second component adapted and configured to provide an aperture through which a secondary device can be positioned wherein the first and second component are connected via a bridging mechanism and further wherein the device is adapted and configured to provide at least one additional tool channel.

98. A device for treating biliary disease comprising:  
a component configured for establishing fluid communication between a gallbladder and a target location within a gastrointestinal tract of a mammal, the component having a proximal end and a distal end with a lumen extending therethrough, a tubular section with a radially extending proximal flange and a radially extending distal flange wherein at least one of the proximal and distal flange is comprised of a first material and the tubular section is comprised of a second material.
99. The device of claim **98** wherein the at least one of the flanges and tubular section is formed from a bioresorbable material.
100. The device of claim **98** wherein the device is removable.
101. The device of claim **98** wherein the device is expandable.
102. The device of claim **98** further comprising one or more configurations selected from a deployment configuration, a delivery configuration and a final configuration.
103. The device of claim **102** further comprising a variable profile.
104. The device of claim **98** wherein a cross-sectional area of the device is variable along a length.
105. The device of claim **98** wherein the device is configured for deployment by at least one of an endoscope, a needle, a guidewire, a guidance catheter and a dilatation catheter.
106. The device of claim **98** further comprising a flareable end.
107. The device of claim **98** wherein the component has one or more clips configured to secure the component at one or more positions.
108. The device of claim **98** further comprising one or more fenestrations.
109. The device of claim **98** wherein the device is flexible.
110. The device of claim **98** wherein the tube has an adjustable length.
111. The device of claim **98** wherein the device is configured at least partially from a shape memory material.

112. The device of claim 98 wherein the device is configured from one or more wires.

113. The device of claim 98 wherein the device is adapted and configured to engage a tubular valve member within the lumen.

114. The device of claim 98 further comprising one or more retaining features adapted and configured to retain the device in situ.

115. The device of claim 98 wherein at least one of the distal flange and proximal flange extend perpendicularly from the tubular section.

116. The device of claim 98 wherein at least one of the distal flange and proximal flange extend from the tubular section and curve back toward the tubular section.

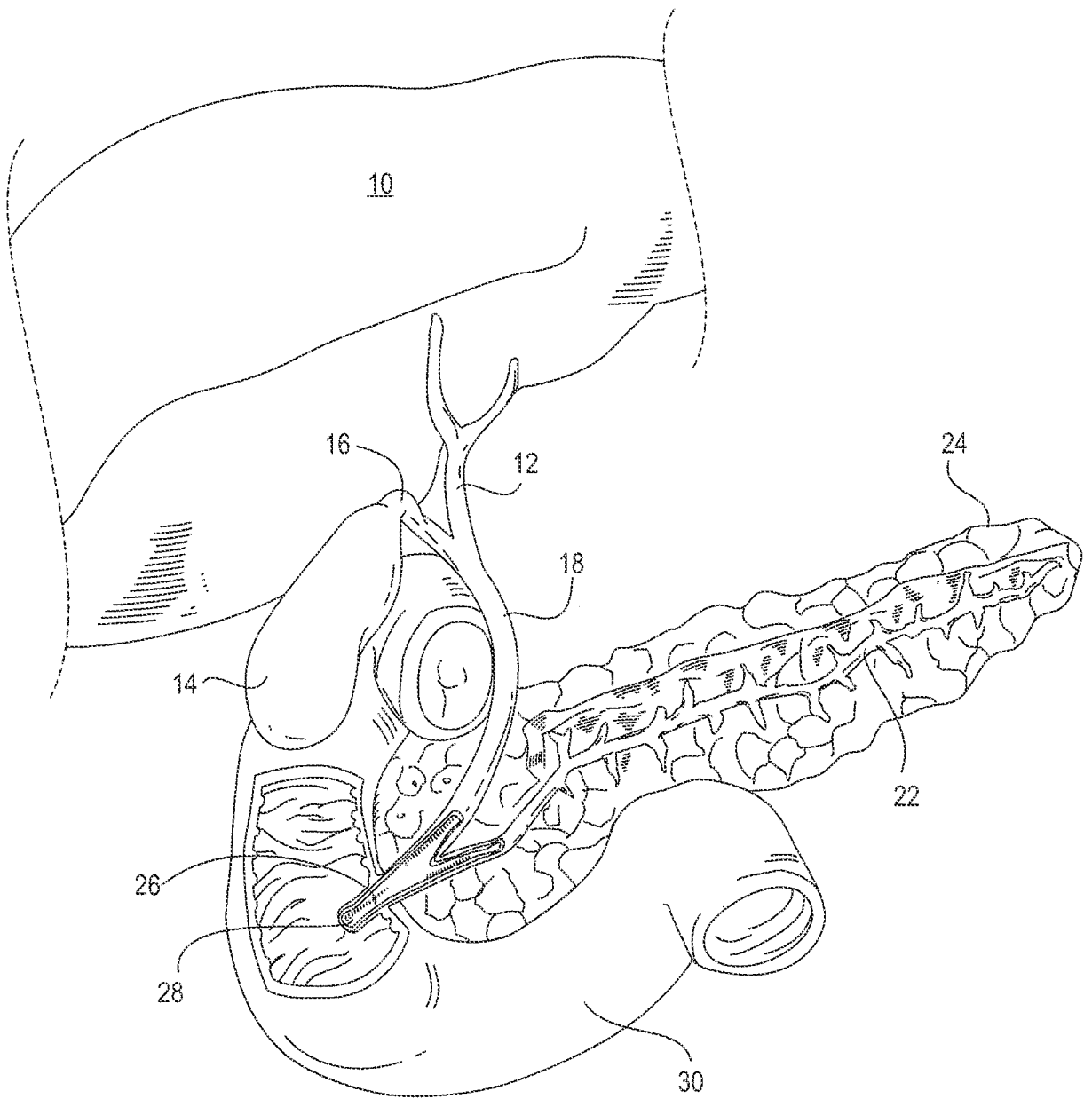

FIG. 1

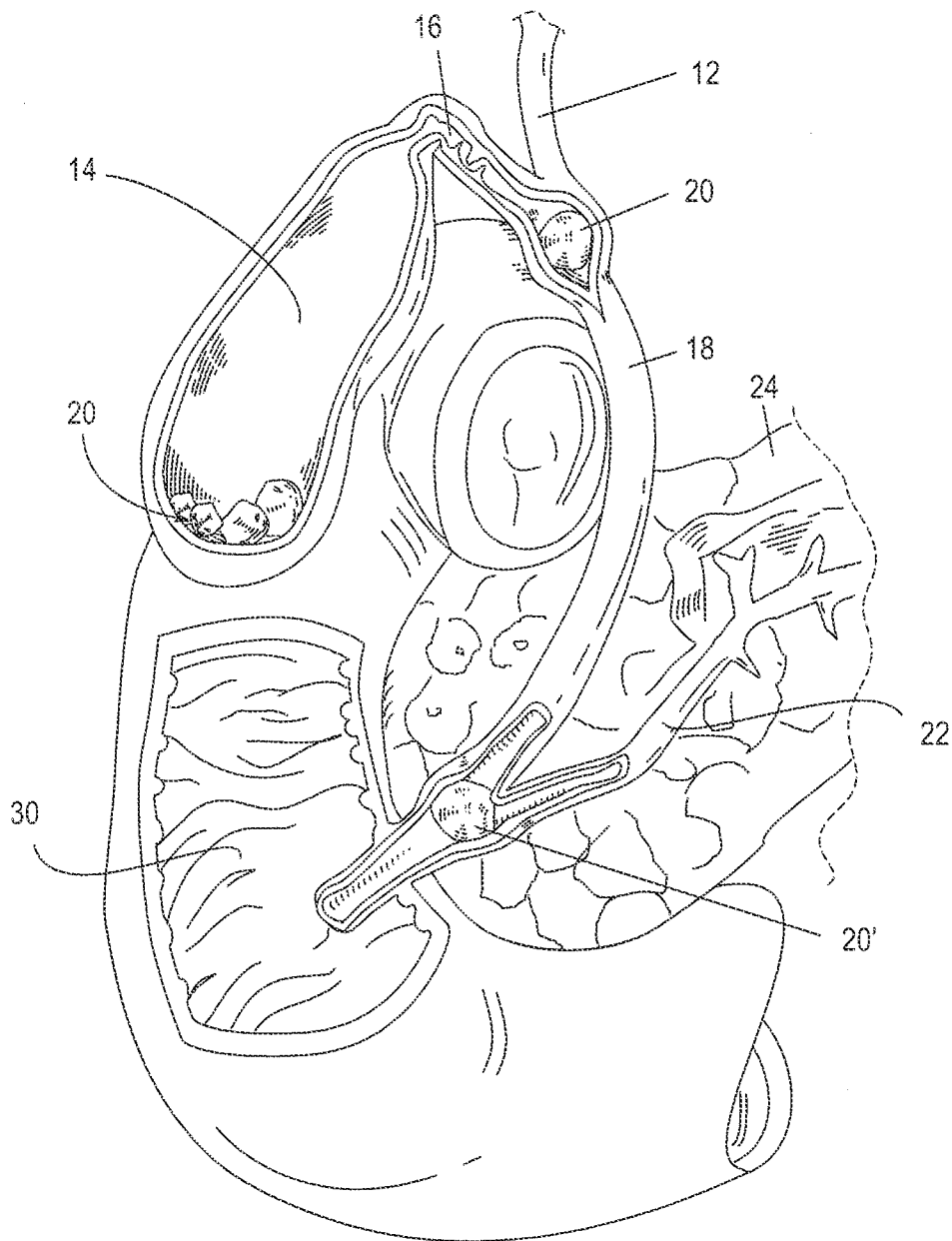

FIG. 2

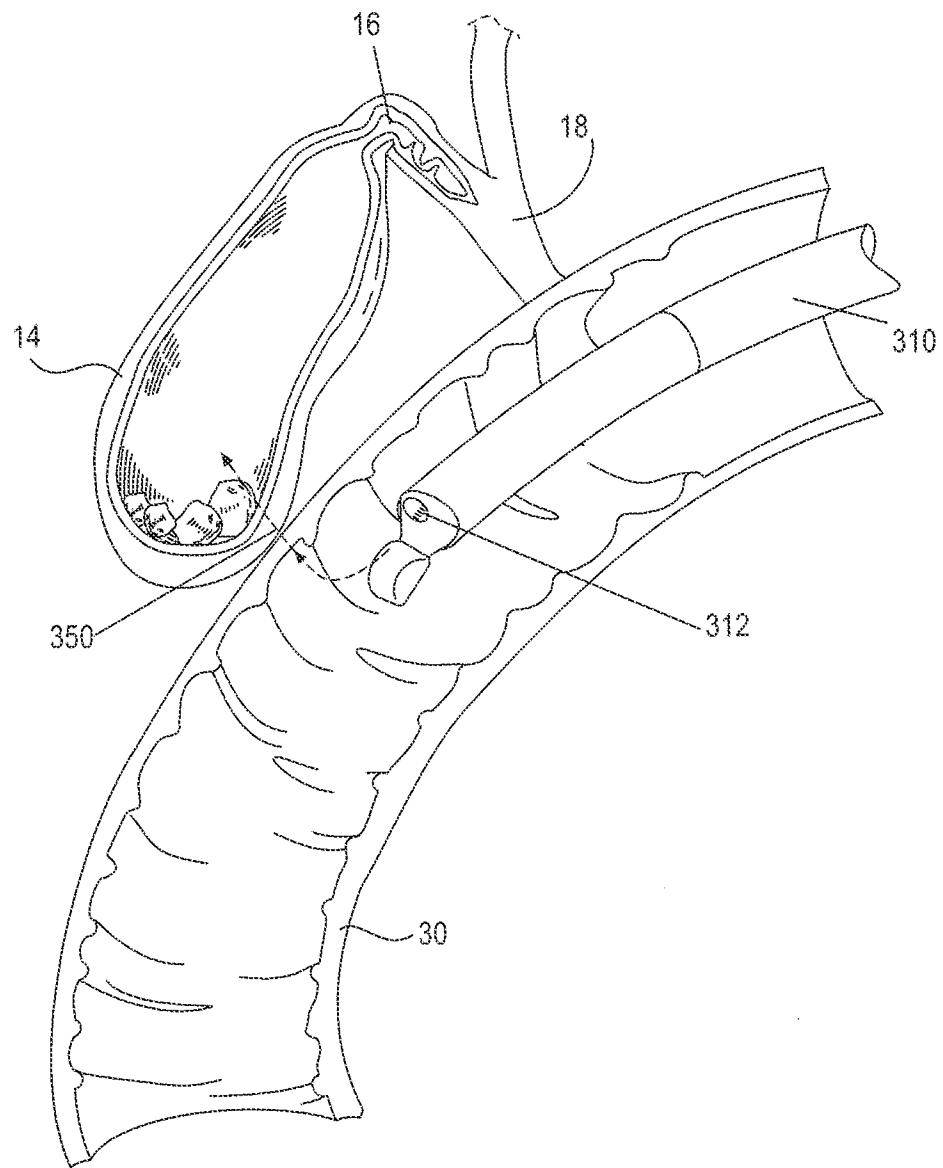

FIG. 3

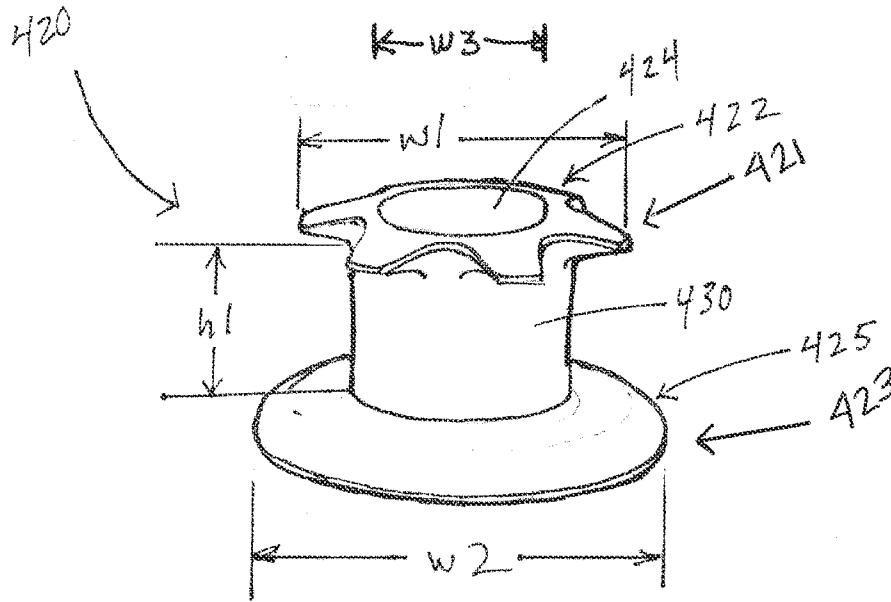

FIG. 4

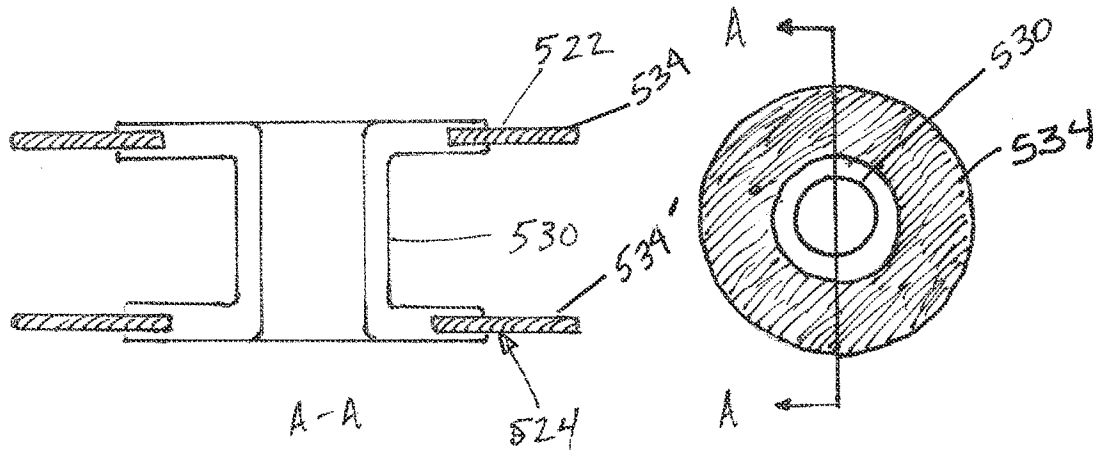

FIG. 5A

FIG. 5B

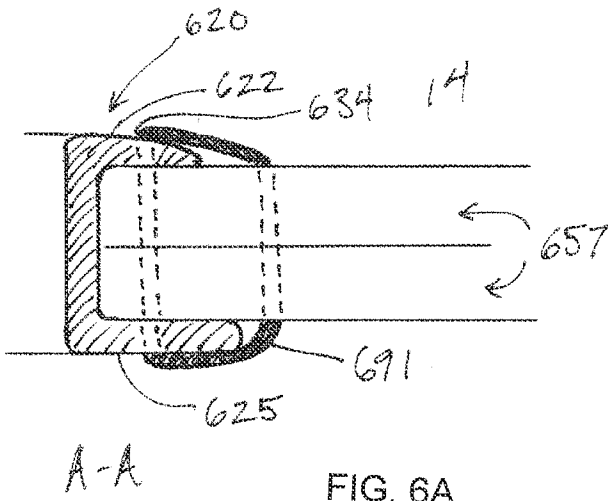

FIG. 6A

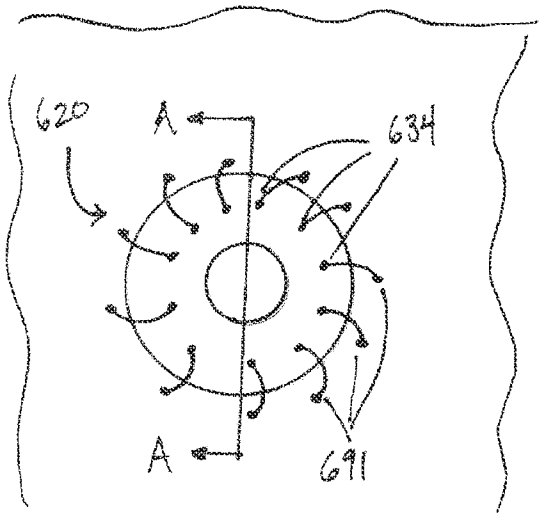

FIG. 6B

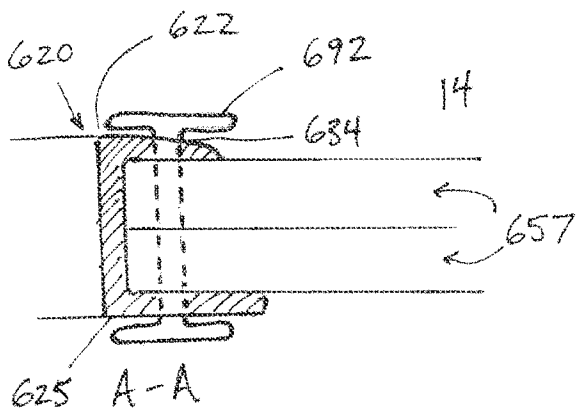

FIG. 6C

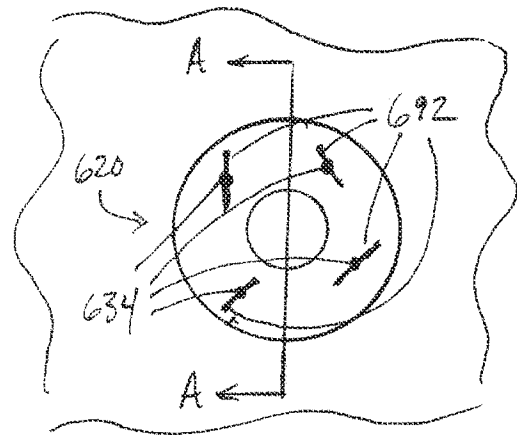
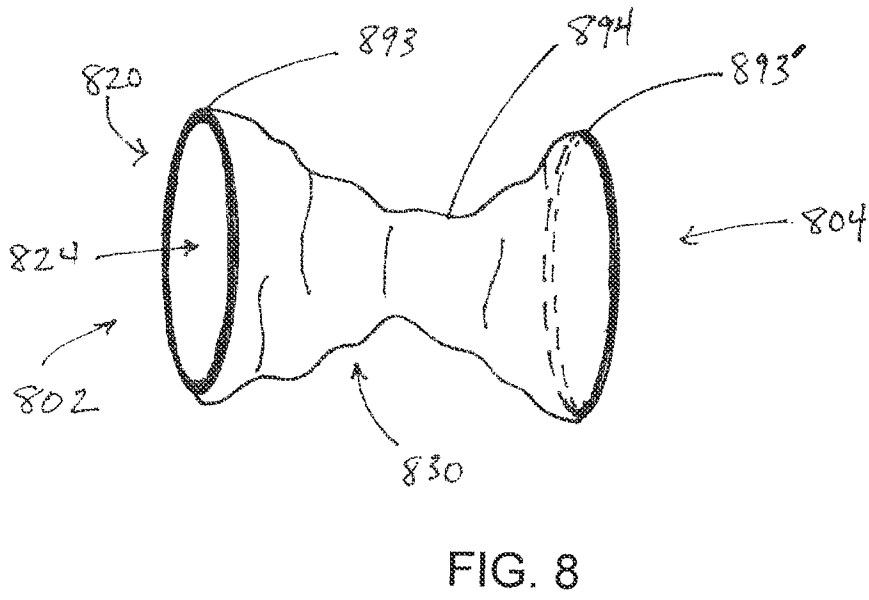
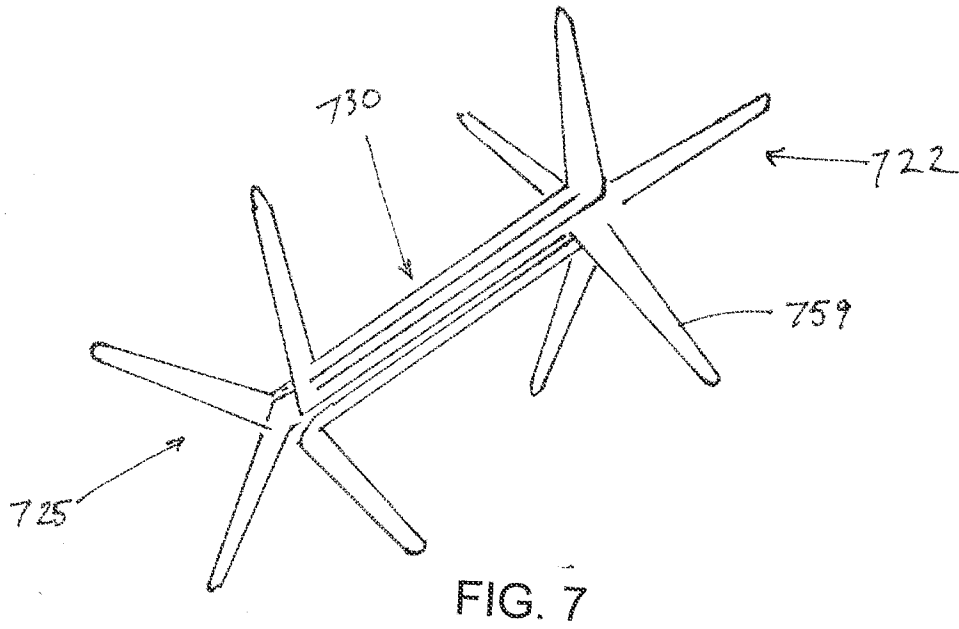

FIG. 6D



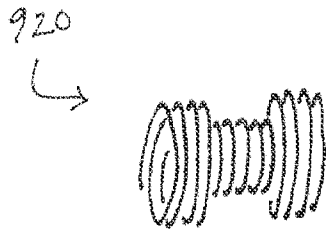

FIG. 9

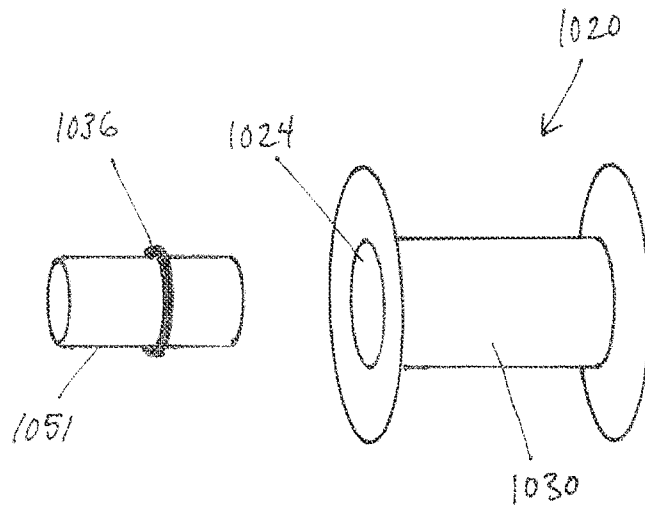

FIG. 10

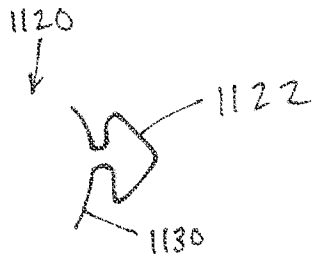

FIG. 11A

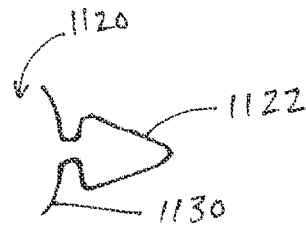

FIG. 11B

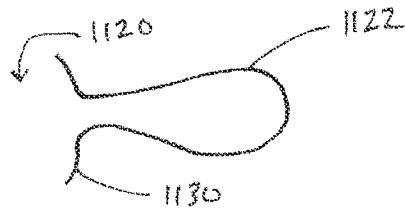

FIG. 11C

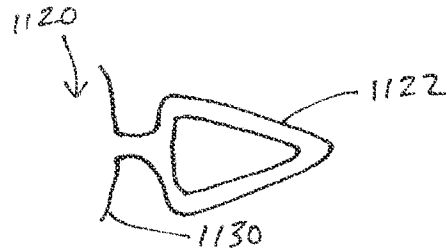

FIG. 11D



FIG. 11E

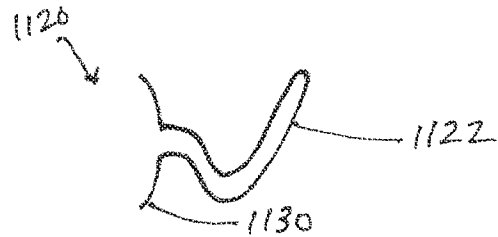

FIG. 11F

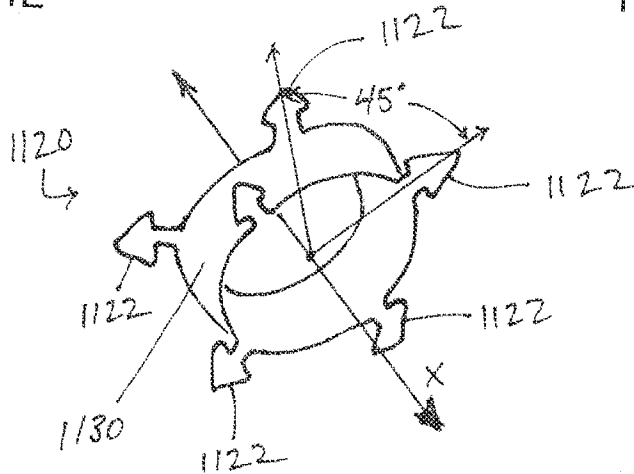

FIG. 11G

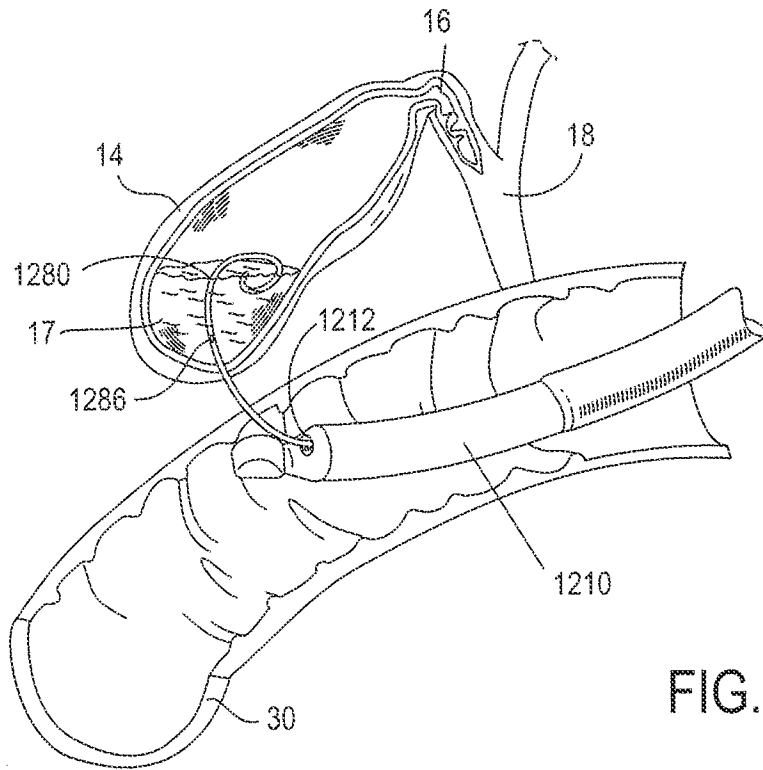

FIG. 12A

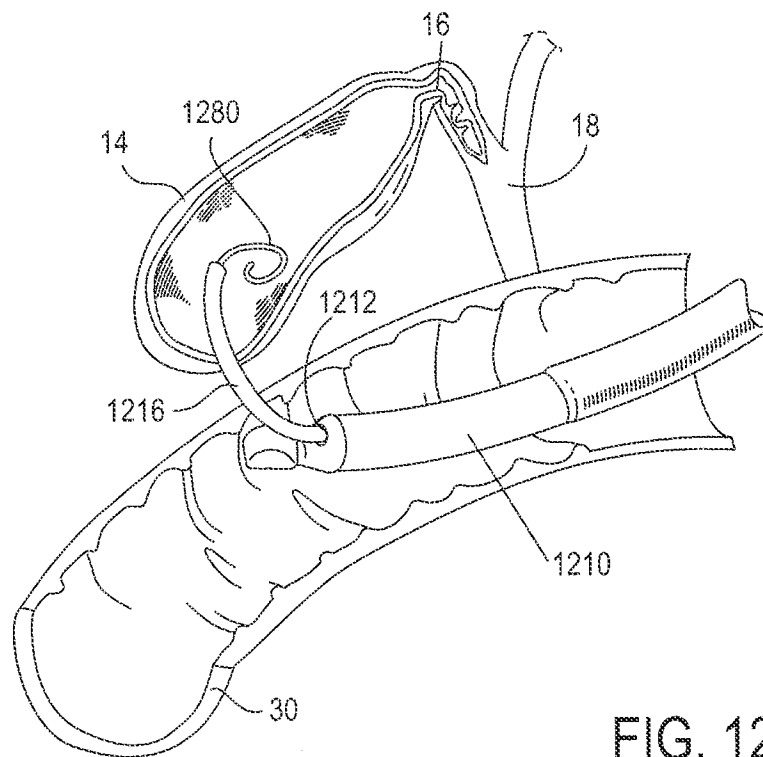

FIG. 12B

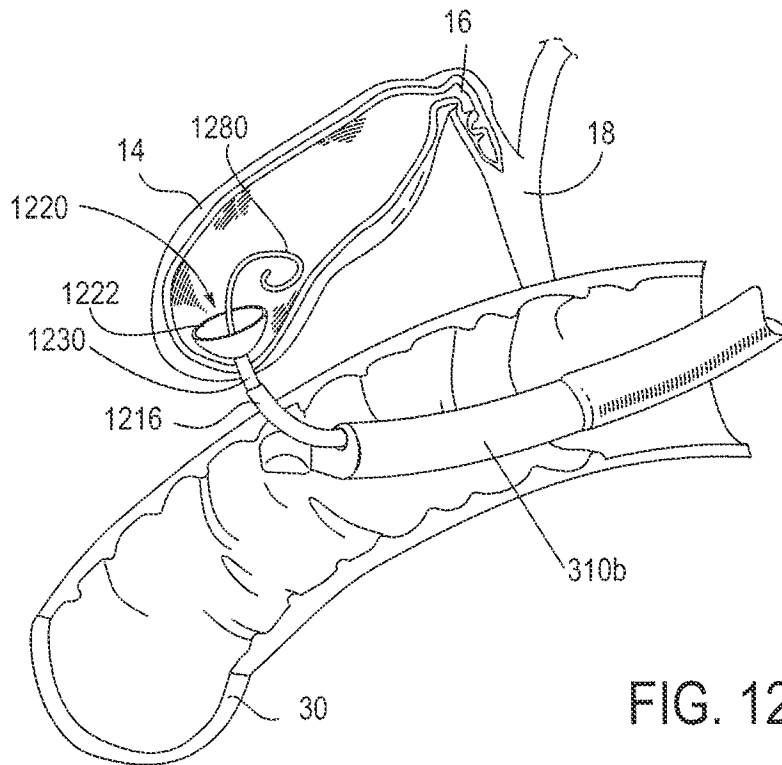

FIG. 12C

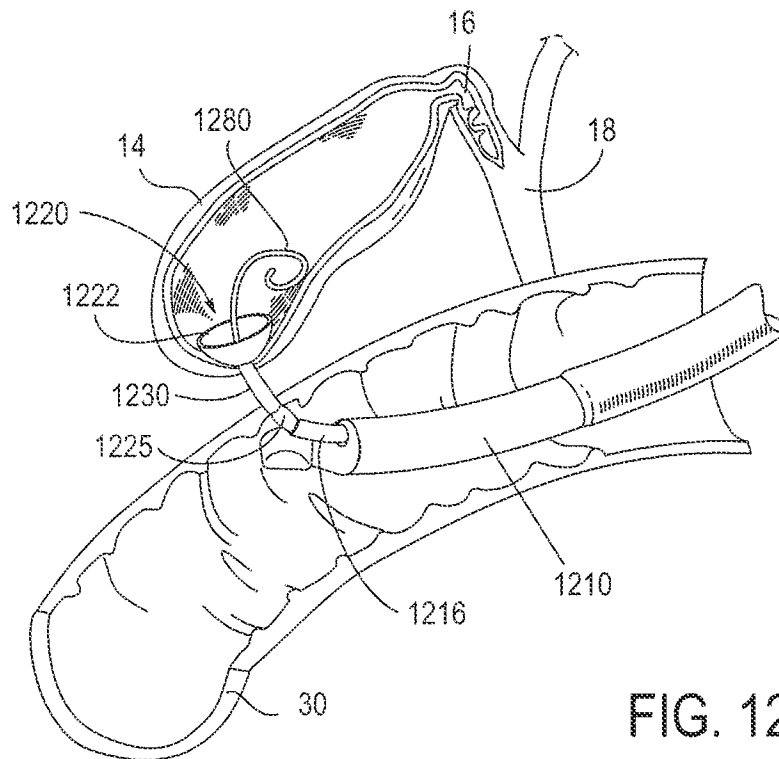

FIG. 12D

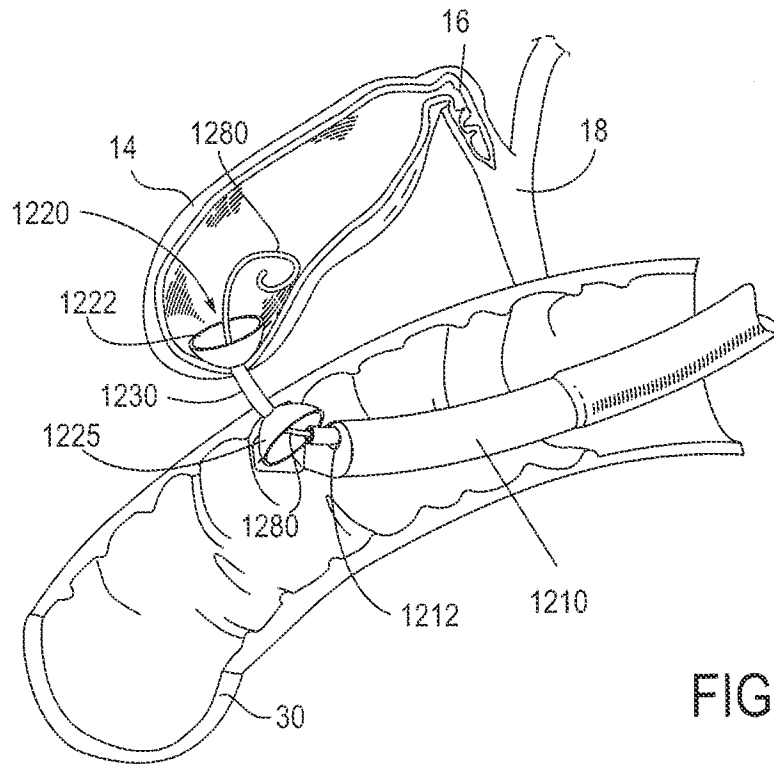
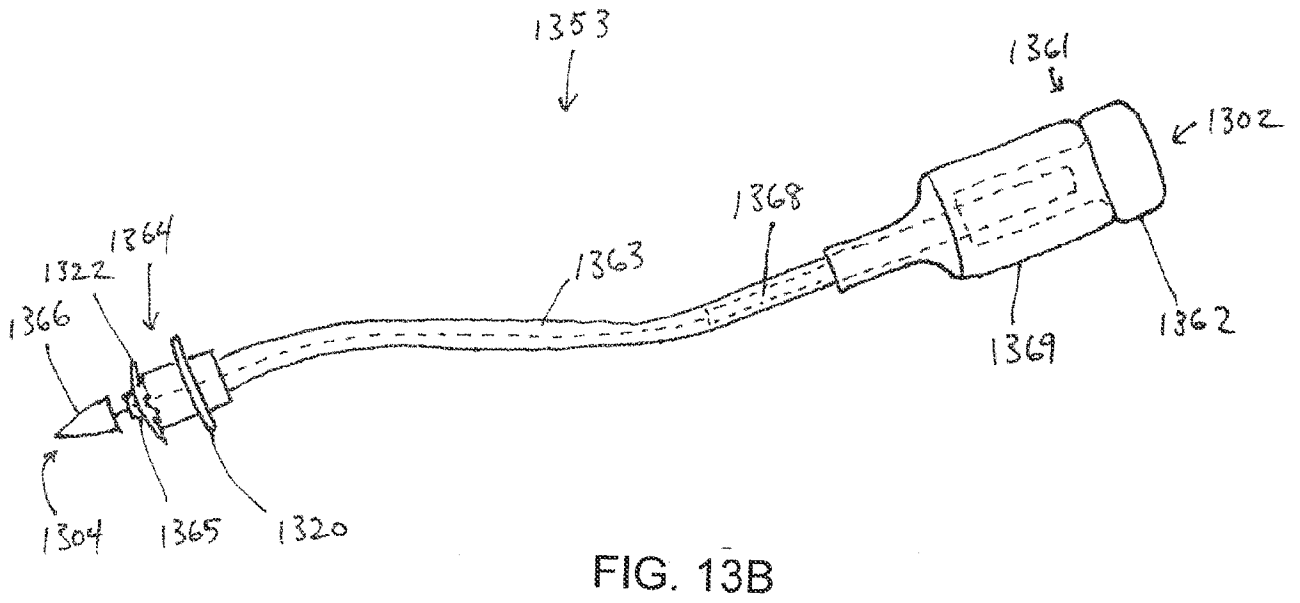
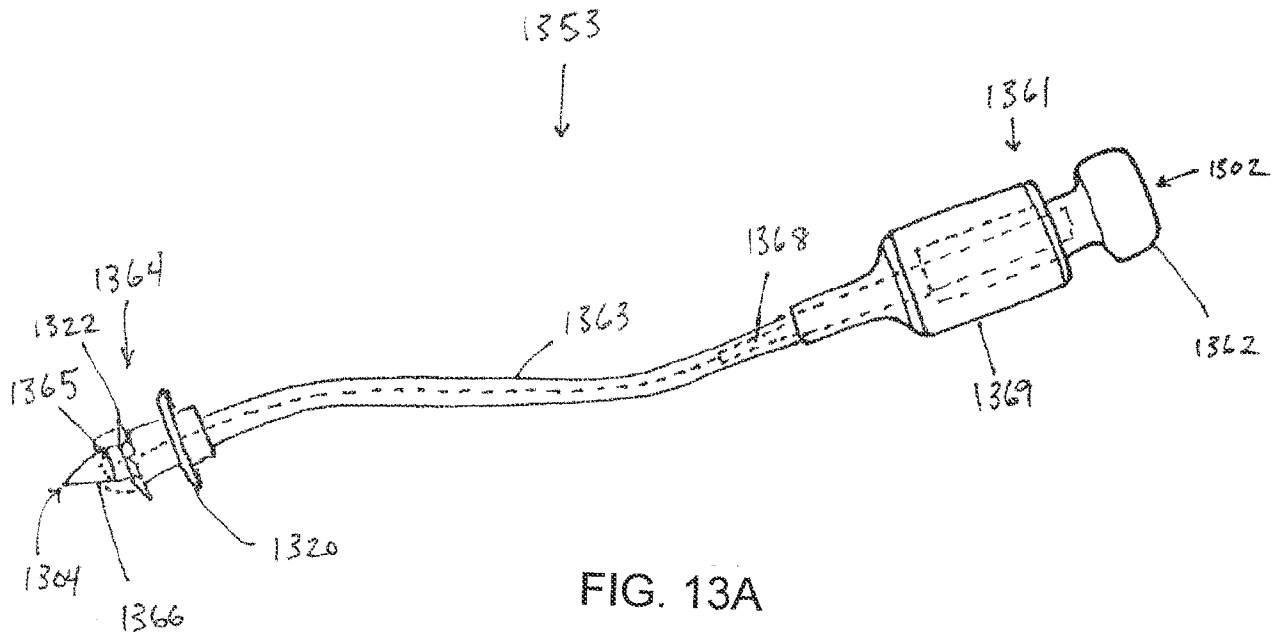

FIG. 12E



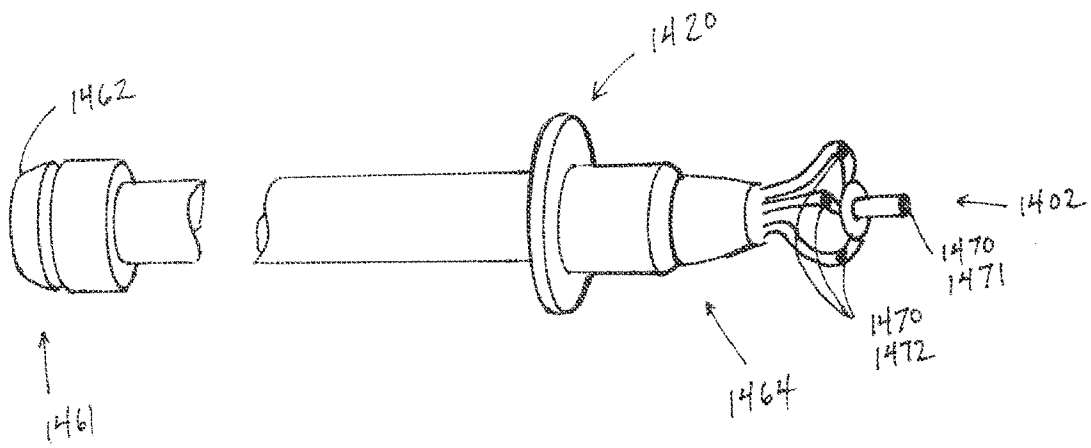
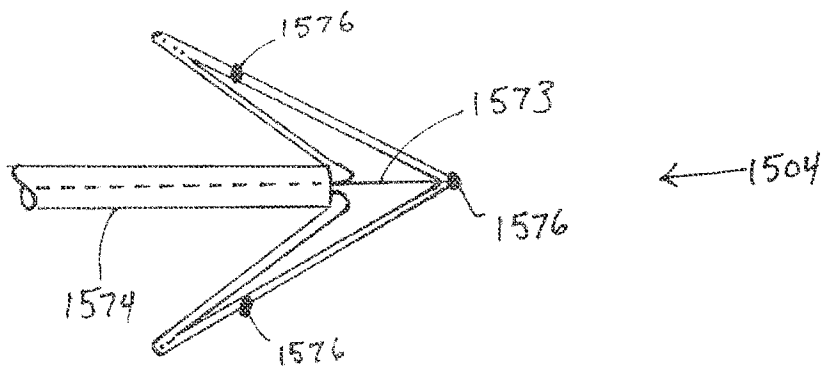
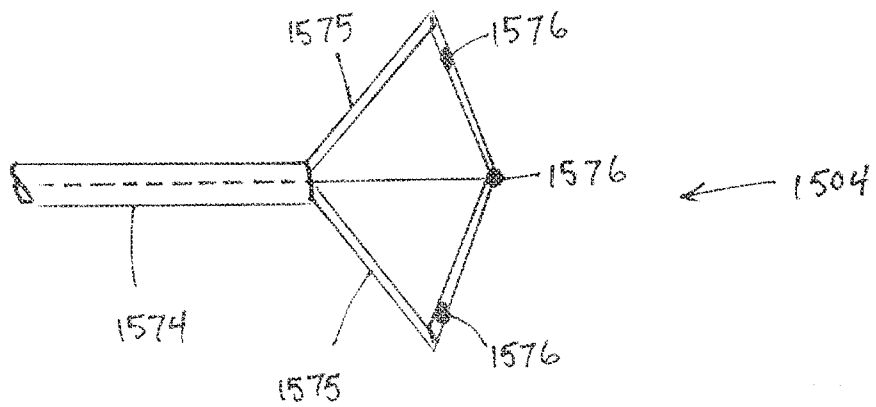
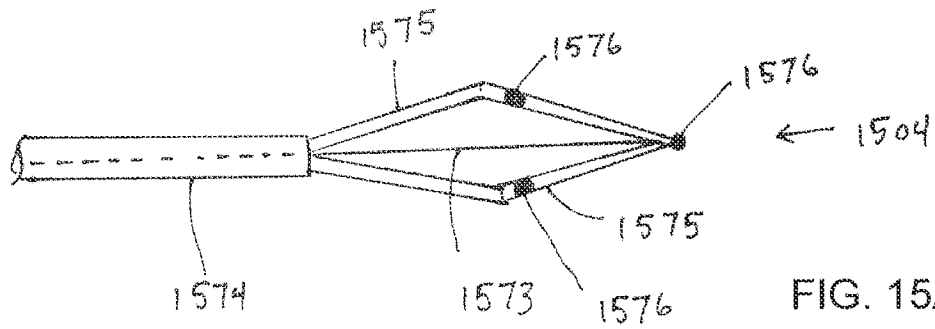

FIG. 14



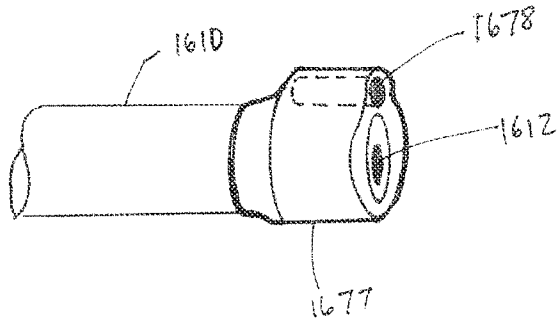

FIG. 16

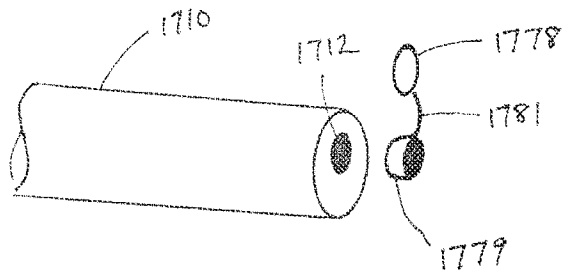

FIG. 17

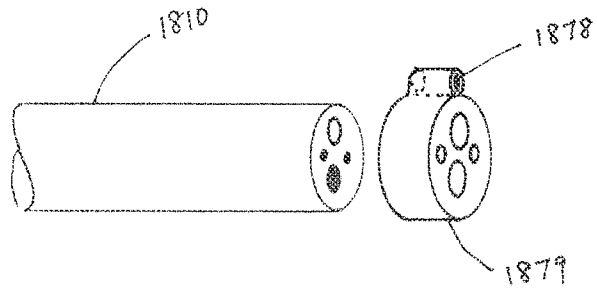

FIG. 18

**A. CLASSIFICATION OF SUBJECT MATTER**

*A61M 31/00(2006.01)i, A61M 25/01(2006.01)i, A61M 25/09(2006.01)i, A61M 25/10(2006.01)i, A61M 29/02(2006.01)i, A61M 39/08(2006.01)i*

According to International Patent Classification (IPC) or to both national classification and IPC

**B. FIELDS SEARCHED**

Minimum documentation searched (classification system followed by classification symbols)

A61M 31/00; A61N 1/05; A61B 17/22; A61M 1/00

Documentation searched other than minimum documentation to the extent that such documents are included in the fields searched

Korean utility models and applications for utility models  
Japanese utility models and applications for utility models

Electronic data base consulted during the international search (name of data base and, where practicable, search terms used)

eKOMPASS(KIPO internal) & Keywords: gallbladder, gastrointestinal, biliary disease

**C. DOCUMENTS CONSIDERED TO BE RELEVANT**

Category*	Citation of document, with indication, where appropriate, of the relevant passages	Relevant to claim No.
X	US 2009-0143713 A1 (VAN DAM et al.) 04 June 2009	1-34, 57-82, 98-116
A	See the abstract; claims 1, 4-11, 13-14, 19-21, and 26; paragraphs [0023]-[0025], [0062], [0065], [0068]-[0069], [0072], and [0086]; and figs. 7E and 20.	83-97
A	US 2008-0195171 A1 (SHARMA) 14 August 2008 See the abstract; claim 1; and fig. 1.	1-34, 57-116

Further documents are listed in the continuation of Box C.

See patent family annex.

\* Special categories of cited documents:

"A" document defining the general state of the art which is not considered to be of particular relevance  
"E" earlier application or patent but published on or after the international filing date  
"L" document which may throw doubts on priority claim(s) or which is cited to establish the publication date of citation or other special reason (as specified)  
"O" document referring to an oral disclosure, use, exhibition or other means  
"P" document published prior to the international filing date but later than the priority date claimed

"T" later document published after the international filing date or priority date and not in conflict with the application but cited to understand the principle or theory underlying the invention  
"X" document of particular relevance; the claimed invention cannot be considered novel or cannot be considered to involve an inventive step when the document is taken alone  
"Y" document of particular relevance; the claimed invention cannot be considered to involve an inventive step when the document is combined with one or more other such documents, such combination being obvious to a person skilled in the art  
"&" document member of the same patent family

Date of the actual completion of the international search

27 FEBRUARY 2012 (27.02.2012)

Date of mailing of the international search report

**28 FEBRUARY 2012 (28.02.2012)**

Name and mailing address of the ISA/KR

 Korean Intellectual Property Office  
Government Complex-Daejeon, 189 Cheongsa-ro,  
Seo-gu, Daejeon 302-701, Republic of Korea

Facsimile No. 82-42-472-7140

Authorized officer

LEE, Cheol Soo

Telephone No. 82-42-481-8525



**Box No. II Observations where certain claims were found unsearchable (Continuation of item 2 of first sheet)**

This international search report has not been established in respect of certain claims under Article 17(2)(a) for the following reasons:

1.  Claims Nos.: 35-56  
because they relate to subject matter not required to be searched by this Authority, namely:  
Claims 35-56 pertain to methods for treatment of human by therapy, and thus relate to a subject matter which this international Searching Authority is not required to search under Article 17(2)(a)(i) of the PCT and Rule 39.1(iv) of the Regulations under the PCT.
2.  Claims Nos.:  
because they relate to parts of the international application that do not comply with the prescribed requirements to such an extent that no meaningful international search can be carried out, specifically:
3.  Claims Nos.:  
because they are dependent claims and are not drafted in accordance with the second and third sentences of Rule 6.4(a).

**Box No. III Observations where unity of invention is lacking (Continuation of item 3 of first sheet)**

This International Searching Authority found multiple inventions in this international application, as follows:

1.  As all required additional search fees were timely paid by the applicant, this international search report covers all searchable claims.
2.  As all searchable claims could be searched without effort justifying an additional fee, this Authority did not invite payment of any additional fee.
3.  As only some of the required additional search fees were timely paid by the applicant, this international search report covers only those claims for which fees were paid, specifically claims Nos.:
4.  No required additional search fees were timely paid by the applicant. Consequently, this international search report is restricted to the invention first mentioned in the claims; it is covered by claims Nos.:

**Remark on Protest**

- The additional search fees were accompanied by the applicant's protest and, where applicable, the payment of a protest fee.
- The additional search fees were accompanied by the applicant's protest but the applicable protest fee was not paid within the time limit specified in the invitation.
- No protest accompanied the payment of additional search fees.

**INTERNATIONAL SEARCH REPORT**

Information on patent family members

International application No.

**PCT/US2010/057736**

Patent document cited in search report	Publication date	Patent family member(s)	Publication date
US 2009-0143713 A1	04.06.2009	EP 2222364 A2	01.09.2010
		GB 2460287 A	25.11.2009
		US 2009-0143759 A1	04.06.2009
		US 2009-0143760 A1	04.06.2009
		US 2011-0071350 A1	24.03.2011
		US 2011-0071566 A1	24.03.2011
		WO 2009-073507 A2	11.06.2009
		WO 2009-073507 A3	06.08.2009
		WO 2009-073515 A2	11.06.2009
		WO 2009-073515 A3	06.08.2009
		WO 2009-073521 A2	11.06.2009
		WO 2009-073521 A3	11.09.2009
		US 2008-0195171 A1	14.08.2008
CA 2714754 A1	21.08.2008		
WO 2008-100974 A2	21.08.2008		
WO 2008-100974 A3	30.12.2009		