

BEST AVAILABLE COPY

J. F. COOLEY.
LUBRICATOR.

APPLICATION FILED DEC. 19, 1908.

1,054,636.

Patented Feb. 25, 1913.

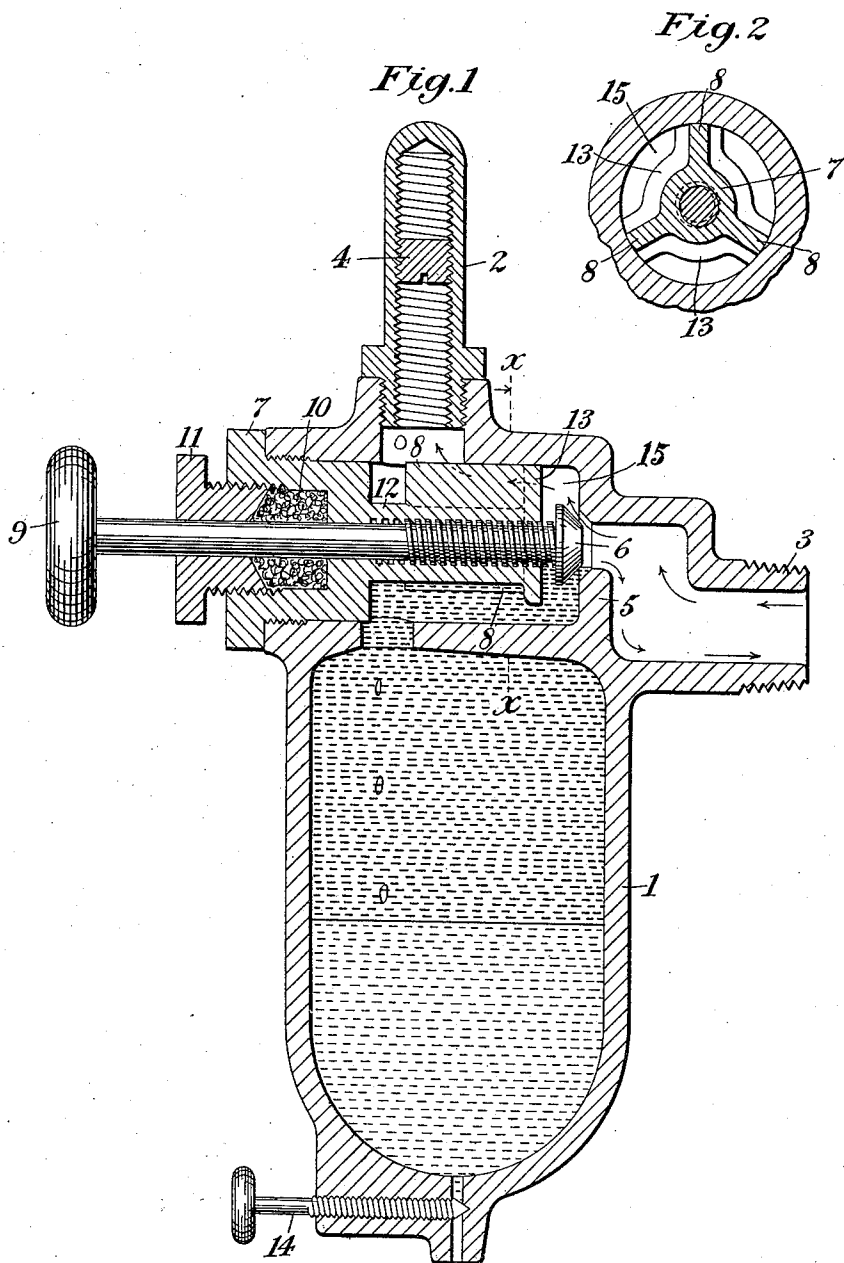

Witnesses:
Victor D. Boral
Chas. Ashley Kelly

Inventor
John F. Cooley
By his Attorney
Henry B. Williams

UNITED STATES PATENT OFFICE.

JOHN F. COOLEY, OF NEW YORK, N. Y., ASSIGNOR, BY MESNE ASSIGNMENTS, TO
CONRAD HUBERT, OF NEW YORK, N. Y.

LUBRICATOR.

1,054,636.

Specification of Letters Patent.

Patented Feb. 25, 1913.

Application filed December 19, 1908. Serial No. 468,315.

To all whom it may concern:

Be it known that I, JOHN F. COOLEY, a citizen of the United States, residing in the borough of Manhattan, city of New York, in the county of New York and State of New York, have invented a certain new and useful Improvement in Lubricators, of which the following is a specification, reference being had therein to the accompanying drawings, forming part thereof.

My invention relates to lubricators, and particularly to that class of lubricators in which a liquid of condensation is introduced into the storage chamber to displace the lubricant.

One object of my invention is to provide means for preventing the hot vapor from contacting with the oil so as to cause it to boil or foam and thus impair the operation of the lubricator.

Another object is to eliminate all minute passages which are liable to clog up and stop the action of the lubricator.

Another object is to provide ready means for entering and cleaning the lubricator.

Another object is to provide novel means for adjusting the size of the condensing chamber.

Still other objects are simplicity, reliability and efficiency of operation.

Other objects and advantages of my invention will appear from the following description.

I shall now describe my invention with reference to the accompanying drawings and shall thereafter point out my invention in claims.

Figure 1 is a central vertical section of my improved lubricator. Fig. 2 is a detail taken on line $x-x$ of Fig. 1, showing the arrangement of the radial wings.

The embodiment of my invention shown in the drawings is especially designed for use in connection with a cylinder of a steam engine, so that a small portion of the steam from the cylinder will enter and condense within the lubricator to serve as the liquid to displace the oil in the storage chamber, and my invention will be described in connection with such use, it being understood that my lubricator may be used in any suitable connection.

I employ the usual storage chamber 1 for the oil, in the top of which is an opening

surrounded by a connector nipple 3 for the entrance of the water of condensation and the passing out of the oil. Screwed in the top of the casing directly over the opening into the oil chamber 1 is a condensing chamber 2, into which steam enters by way of the opening through the connector-nipple 3, as indicated by the arrows, and is gradually condensed and drips into the storage chamber 1, and, being of greater specific gravity than the oil, displaces the oil and forces it out in the well known way. To vary the rate of condensation, the size of the condensing chamber 2 may be varied, and for this purpose I make the chamber internally screw-threaded and provide therein a solid imperforate screw plug 4, which may be screwed up or down with a screw driver when the chamber 2 is removed to increase or decrease the size of the active or effective portion of the condensing chamber, without requiring outside openings in the chamber. Should very great variation in size be desired, the chamber may be replaced by a larger or smaller chamber, as desired. It will be evident that there is a decided advantage in having the interior of the chamber 2 screw-threaded, since the condensing surface and rate of condensation are thereby materially increased.

To prevent water in the cylinder from backing up and getting into the oil chamber and forcing out the oil in too large quantities, I provide in the duct of the connector-nipple 3 an elbow or water trap 5, and at the inner end of this duct is formed a valve seat for a stop valve 6, which serves to temporarily close connection with the source of condensable fluid and parts to be lubricated in an obvious manner.

The hot inflowing steam, after passing the valve seat on its way to the condensing chamber enters a chamber or conduit 15 located between the condensing chamber and storage chamber. To prevent it from coming in contact with the oil, which flows through the conduit 15 from the storage chamber to the valve seat and at the same time afford ready access to the interior of the lubricator for cleaning or repairing or replacing of parts, the conduit 15 has a cylindrical bore and is provided with a removable screw-plug 7, and on the inner extension of this plug are a plurality of radial wings 8

(shown as three) which fit snugly in the bore of the conduit 15, as shown in Fig. 2; and the two lowermost of the wings serve as partitions to prevent communication between the incoming steam and the oil in the conduit 15. It is evident that to serve this purpose the wings must be arranged substantially as shown in the drawings with the upper one vertical, and that the plug 7 need be given less than one-third of a turn to bring it to this position from any other position. Obviously the number of the radial wings 8 may be varied as desired, but I have found three to be the most convenient number.

The spindle of the valve 6 extends longitudinally through a bore in the plug 7 and on its inner end is screw-threaded to provide means for longitudinal adjustment to and from the valve seat, and is provided on its outer end with a hand-wheel 9 for manual adjustment of the valve. To render the bore steam-tight, the usual packing gland 10 and gland nut 11 are provided.

To furnish a passage for the water of condensation to drip from the condensing chamber 2 to the storage reservoir 1, the wings 8 are cut away at their ends farthest removed from the steam inlet, leaving a cylindrical neck portion 12 below the condensing chamber 2 and above the opening in the storage chamber 1, and out of the path of the inflowing steam. Some steam will also condense on the wings 8, and this, together with the water of condensation from the condensing chamber 2, which drips upon the wings, is prevented from running off the ends of the wings adjacent to the valve seat and from mingling with the outgoing oil, by flanges 13 on the outer end of the wings and plug, which retain this water and cause it to flow into the storage chamber 1. The drain cock 14 at the bottom of the storage chamber 1 is provided to draw off the water collected in the storage chamber preparatory to refilling.

A usual sight gage (not shown) is provided to determine the height of the water and the quantity of oil in the storage chamber, and when the oil is exhausted, the water is drawn off through the drain cock. Then, after removing the condensing chamber 2, the storage chamber is again filled with oil through the opening thus provided, the valve 6 first being closed to insure that all of the oil will run into the storage chamber.

In my improved lubricator, there is an entire absence of small passages liable to become clogged up and impede the operation of the lubricator, and all the openings are large and easily accessible for cleaning.

It is obvious that various modifications may be made in the construction shown and above particularly described within the principle and scope of my invention.

I claim:

1. A lubricator comprising, in combination, a condensing chamber, a storage chamber for lubricating fluid communicating with the condensing chamber so as to receive condensed liquid therefrom, a conduit between the condensing chamber and storage chamber connected to receive vaporized liquid for the condensing chamber, to convey condensed liquid from the condensing chamber to the storage chamber and to convey displaced lubricating fluid out of the lubricator, and a removable partition in such conduit to shield the lubricating fluid from the vaporized liquid.

2. A lubricator comprising, in combination, a storage chamber for lubricating fluid, an internally screw threaded condensing chamber sealed at its upper end and having an opening at its lower end and in continuous and uninterrupted communication at all times with said storage chamber to deliver condensed liquid thereto, an imperforate space varying plug having external threads thereon and engaging the internal screw threads of the condensing chamber and adjustable therein through the open end of said chamber to vary the extent of exposure of the condensing chamber to the condensable vapor, a conduit for supplying vaporized liquid to the condensing chamber and conveying displaced lubricating fluid out of the lubricator, and means operative independently of the space varying plug for opening and closing the conduit.

3. A lubricator comprising, in combination, a condensing chamber having an adjustable space-varying plug therein, a storage chamber for lubricating fluid communicating with the condensing chamber so as to receive condensed liquid therefrom, a conduit between the condensing chamber and storage chamber connected to receive vaporized liquid for the condensing chamber, to convey condensed liquid from the condensing chamber to the storage chamber and to convey displaced lubricating fluid out of the lubricator, and a removable partition in such conduit to shield the lubricating fluid from the vaporized liquid.

4. A lubricator comprising, in combination, a condensing chamber, a storage chamber for lubricating fluid, a conduit between the condensing chamber and storage chamber connected to receive vaporized liquid for the condensing chamber, to convey condensed liquid from the condensing chamber to the storage chamber and to convey displaced lubricating fluid out of the lubricator, and a removable partition in such conduit to shield the lubricating fluid from the vaporized liquid, such partition having a flange at the end thereof in proximity to the inlet for vaporized liquid and having an

opening at its other end to convey condensed liquid to the storage chamber.

5. A lubricator comprising, in combination, a condensing chamber, a storage chamber for lubricating fluid communicating with the condensing chamber so as to receive condensed liquid therefrom, a conduit between the condensing chamber and storage chamber connected to receive vaporized liquid for the condensing chamber and to convey displaced lubricating fluid out of the lubricator, and a removable plug in the conduit having a plurality of wings thereon forming a partition in such conduit to shield the lubricating fluid from the vaporized liquid.

6. A lubricator comprising, in combination, a condensing chamber, a storage chamber for lubricating fluid, a conduit between the condensing chamber and storage chamber connected to receive steam for the condensing chamber and to convey displaced lubricating fluid out of the lubricator, a removable plug in the conduit having a plurality of wings thereon forming a partition in such conduit to shield the lubricating fluid from the vaporized liquid, the wings and plug having flanges at the ends thereof in proximity to the inlet for vaporized liquid and the wings terminating so as to provide openings at the other ends thereof to convey condensed liquid to the storage chamber.

7. A lubricator comprising, in combination, a condensing chamber, a storage chamber for lubricating fluid communicating with the condensing chamber so as to receive condensed liquid therefrom, a conduit between the condensing chamber and storage chamber connected to receive vaporized liquid for the condensing chamber and to convey displaced lubricating fluid out of the lubricator, a removable plug in one end of the conduit having a plurality of wings thereon forming a partition in such conduit to shield the lubricating fluid from the vaporized liquid, and a shut-off valve for the conduit having a spindle extending longitudinally through the removable plug.

8. A lubricator comprising, in combination, an internally screw-threaded condensing chamber, a storage chamber for lubricating fluid communicating with the condensing chamber so as to receive condensed liquid therefrom, a conduit between the condensing chamber and storage chamber connected to receive vaporized liquid for the condensing chamber, to convey condensed liquid from the condensing chamber to the storage chamber and to convey displaced lubricating fluid out of the lubricator, and a removable partition in such conduit to shield

the lubricating fluid from the vaporized liquid.

9. A lubricator comprising, in combination, an internally screw-threaded condensing chamber having an adjustable space-varying plug therein, a storage chamber for lubricating fluid communicating with the condensing chamber so as to receive condensed liquid therefrom, a conduit between the condensing chamber and storage chamber connected to receive vaporized liquid for the condensing chamber and to convey displaced lubricating fluid out of the lubricator, and a removable plug in the conduit having a plurality of wings thereon forming a partition in such conduit to shield the lubricating fluid from the vaporized liquid.

10. A lubricator comprising, in combination, an internally screw-threaded condensing chamber having an adjustable space-varying plug therein, a storage chamber for lubricating fluid, a conduit between the condensing chamber and storage chamber connected to receive steam for the condensing chamber and to convey displaced lubricating fluid out of the lubricator, a removable plug in the conduit having a plurality of wings thereon forming a partition in such conduit to shield the lubricating fluid from the vaporized liquid, the wings and plug having flanges at the ends thereof in proximity to the inlet for vaporized liquid and the wings terminating so as to provide openings at the other ends thereof to convey the condensed liquid to the storage chamber.

11. A lubricator comprising, in combination, an internally screw-threaded condensing chamber having an adjustable plug therein, a storage chamber for lubricating fluid, a conduit between the condensing chamber and storage chamber connected to receive vaporized liquid for the condensing chamber and to convey displaced lubricating fluid out of the lubricator, a removable plug in one end of the conduit having a plurality of wings thereon forming a partition in such conduit to shield the lubricating fluid from the vaporized liquid, the wings and plug having flanges at the ends thereof in proximity to the inlet for vaporized liquid and the wings terminating so as to provide openings at the other ends thereof to convey the condensed liquid to the storage chamber, and a shut-off valve for the conduit having a spindle extending longitudinally through the removable plug.

In testimony whereof I have affixed my signature in presence of two witnesses.

JOHN F. COOLEY.

Witnesses:

VICTOR D. BORST,
BERNARD COWEN.