



(22) Date de dépôt/Filing Date: 1996/05/15
 (41) Mise à la disp. pub./Open to Public Insp.: 1996/11/20
 (45) Date de délivrance/Issue Date: 2008/07/15
 (30) Priorité/Priority: 1995/05/19 (US08/444,969)

(51) Cl.Int./Int.Cl. *G01V 15/00* (2006.01),
B07C 3/12 (2006.01), *B07C 5/344* (2006.01),
G06K 19/07 (2006.01), *G06K 19/077* (2006.01),
H01Q 1/38 (2006.01), *H05K 1/16* (2006.01),
H05K 3/00 (2006.01)

(72) Inventeurs/Inventors:
 FERGUSON, DONALD HAROLD, CA;
 PAUN, MIRCEA, CA

(73) Propriétaire/Owner:
 INTERNATIONAL POST CORPORATION SC, BE

(74) Agent: TORYS LLP

(54) Titre : ETIQUETTE D'IDENTIFICATION DE RADIO FREQUENCE
 (54) Title: RADIO FREQUENCY IDENTIFICATION TAG

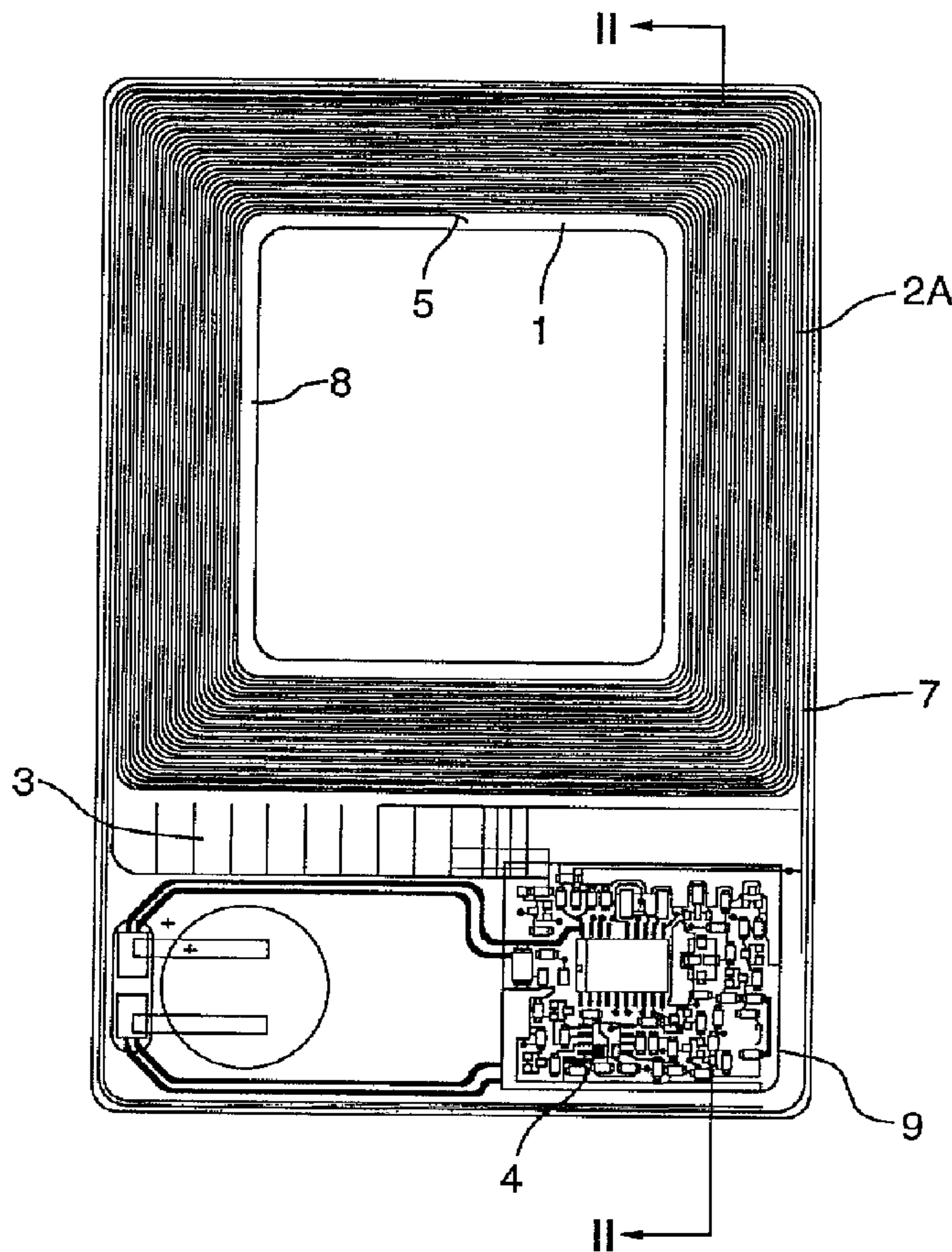

(57) Abrégé/Abstract:

A radio frequency identification tag with printed antenna coil integrated on a flexible substrate, and an integrated circuit area of the substrate adjacent the antenna coil for carrying circuit elements. The radio frequency identification tag is designed to be sufficiently robust to withstand the rigors of mail efficiency processing measurement applications

2176625

ABSTRACT

5 A radio frequency identification tag with printed antenna coil integrated on a flexible substrate, and an integrated circuit area of the substrate adjacent the antenna coil for carrying circuit elements. The radio frequency identification tag is designed to be sufficiently robust to withstand the rigors of mail efficiency processing measurement applications

RADIO FREQUENCY IDENTIFICATION TAGField of the Invention

5 The present invention relates in general to electro-mechanical circuit design, and more particularly to a flexible radio frequency identification tag for mail efficiency measurement applications.

10 Background of the Invention

 Traditional circuit board assemblies use rigid insulated materials to form a substrate for the mounting of electronic components. According to well known prior art designs, the signal flow between electronic components is effected by wire connections (e.g. copper traces) printed on the substrate. The electronic components themselves are connected to these wire traces via solder. The rigidity of the substrate material prevents cracking of the copper solder joint connections and insures the integrity of these connections when the device is subjected to mechanical stress.

 Certain specialized applications require circuit board assemblies of size greater than approximately 4 cm² to be flexible. One such application is mail efficiency processing measurement wherein the circuit board assemblies are disposed within or on envelopes which pass through mail sorting equipment. The circuit board assemblies in such an application may be designed to incorporate low frequency antennae and associated electronic circuitry. The circuit board assembly must be designed to withstand the stresses of being passed through mechanical sorting machines.

35 Summary of the Invention

 According to the present invention, a radio frequency identification tag is provided having a printed RF coil integrated with a flexible substrate, and an

integrated circuit area of the substrate adjacent the coil, wherein the integrated circuit area is reinforced to protect electrical components thereon. The radio frequency tag of the present invention is designed to endure mechanical stresses far in excess of the stresses which standard circuit board assemblies are normally subjected to. The tag of the present invention is also designed to be sufficiently thin and light for use in mail processing measurement applications.

The integrated antenna and circuit area are disposed on the same substrate thereby resulting in increased reliability and decreased complexity over prior art designs having antenna elements separate from the sensing circuit.

BRIEF DESCRIPTION OF THE DRAWINGS

A detailed description of the preferred embodiment is provided herein below with reference to the following drawings, in which:

Figures 1A and 1B are top and bottom plan views of the radio frequency identification tag according to the present invention;

Figure 2 is a cross-section through the line II-II in Figures 1A and 1B;

Figure 3 is an expanded view of the portion shown in phantom outline in Figure 1A; and

Figure 4 is a schematic diagram of a representative circuit carried by the integrated circuit area of the tag shown in Figures 1-3.

DETAILED DESCRIPTION OF THE PREFERRED EMBODIMENT

With reference to the Figures 1 and 2, a radio frequency tag is shown comprising a flexible substrate 1 on opposite sides of which a receive antenna coil 2 is provided. The antenna coil 2 comprises a first winding

2A on the top side of the substrate and a second winding 2B on the bottom of the substrate, as shown best in Figures 1A and 1B, respectively. The substrate 1 is preferably made from standard industrial grade epoxy glass laminate, type FR-4, such as manufactured by
5 ADJ/Isola or NAN YA. According to the preferred embodiment, the core thickness of the substrate is made 8 mils, at Class 3 tolerance (i.e. 8 ± 1 mil).

The size and efficiency of the antenna 2 is
10 determined by the following variables:

1. the excitation frequency,
 2. sensitivity requirements,
 3. effective area of the coil,
 4. number of turns of the coil,
 - 15 5. Q factor of the coil,
- all of which are limited by
6. package size.

The size of the LF antenna 2 for the mail processing application discussed above, is limited by the postal
20 envelope size specifications as dictated by any particular application. Antenna efficiency is optimized by maximizing antenna size and minimizing resistive losses in a tuned circuit configuration within the boundaries determined by the packaging constrains. It
25 should be noted that for all low frequency excitation applications, the antenna 2 should be designed to be as large as possible for maximum efficiency.

Tuning of the antenna 2 in the identification tag of the present invention, is accomplished by first measuring
30 the inductance, parasitic capacitance and resistance of the antenna at its terminals (i.e. at multiple connections 3 between the embedded antenna windings 2A and 2B and the integrated circuit area 4, discussed in greater detail below). The inductance, parasitic
35 capacitance and resistance of the antenna 2 are measured at the intended excitation frequency (in the case of the postal tag application referred to herein above - 135

KHz). Decreasing parasitic capacitance improves antenna efficiency. Once the characteristic impedance of the antenna 2 has been measured, a calculated parallel capacitance is added in order to tune the circuit to resonate at the selected excitation frequency. Turning briefly to the preferred embodiment of Figure 4, this capacitance is provided by capacitors C1 and C2 connected in parallel with the antenna 2.

Without the addition of an external capacitor (e.g. parallel capacitance provided by capacitor C1 and C2 in Figure 4), the embedded antenna 2 is characterized by its own self resonance determined by its inductance and parasitic capacitance.

The desired parallel capacitance C is given by:

$$C = 1/L\omega^2$$

where L is the measured inductance, $\omega = 2\pi f_0$, and f_0 is the excitation frequency.

It is important to note that the size, shape and number of turns of the embedded coil 2 are limited by packaging constraints and the excitation frequency (f_0), and that these variables may change with changes in the selected excitation frequency and packaging requirements.

In order to increase the inductance of the embedded LF antenna coil 2, the windings 2A and 2B are printed on both sides of the substrate 1 and are connected together via single plated through hole 5.

According to the preferred embodiment, the antenna traces 2A on the top side of the substrate 1 are offset from the antenna traces 2B on the bottom of the substrate to minimize parasitic capacitance therebetween. The degree of offset is based on the spacing between the traces and the width of the traces themselves. Generally, the traces 2B on the underside of substrate 1 should be offset such that the middle of the width of each trace is referenced to the middle space between traces 2A on the top side of the substrate 1.

It should be noted that any application using a

specific receiver frequency must have a specific design layout optimized for that frequency and application. Applications where the tag requires a different received frequency will normally require a different layout.

5 Circuit elements carried by the integrated circuit area 4 of the tag are interconnected via copper traces in the usual manner. According to the preferred embodiment, the copper thickness is double sided at $\frac{1}{2}$ ounce per square foot. This results in a net tag thickness of
10 0.008 inches of core material coupled with $\frac{1}{2}$ ounce copper, which results in good flexibility at low cost.

 The tag of the present invention is fabricated using industry standard processes for the manufacture of flex circuit boards, with close attention being paid to the plating requirements for forming connections via the
15 through holes from one side of the substrate 1 to the other (e.g. hole 5). Excessive plating may increase the total weight above acceptable limits and make the board less flexible, while deficient plating may increase the
20 resistance of the antenna 2, thereby decreasing efficiency. According to the preferred embodiment, a protective solder mask coating is placed over top of the integrated circuit area 4 after etching. It should be noted that care must be taken in the application of the
25 solder mask to ensure a thin even coat. If the solder mask is applied too thickly, the tag may exceed weight requirements for a particular application.

 After processing, the printed circuit board (PCB) formed on substrate 1 is characterized by the following
30 specifications:

 Copper thickness after plating (addition - both sides - total): 0.5 mils (plus 0.2 - 0) mils

 Solder mask thickness each side: 11.4 \pm 1 mils

 Total weight of the PCB: 5.5 \pm .5g

35 Coil inductance (640 \pm 5) μ H at 135 KHz

 Coil Q (quality factor): 8.0 \pm 0.5 at 135 KHz

 In order to further optimize weight characteristics

of the identification tag, portions of the substrate 1 are cut out where not required to support operative circuit elements. As shown in Figures 1A and 1B, a rectangular portion 8 of the substrate 1 is cut out from the centre of the antenna coil windings 2A and 2B.

According to the preferred embodiment, efficiency, selectivity and sensitivity are further improved by gold plating the etched printed circuit board for increasing the conductivity of the traces of coil windings 2A and 2B. The resistance of each coil winding 2A, 2B decreases when the copper traces are gold plated. The Q value of the coil increases as a result. The Q factor is an indication of efficiency and selectivity of the coil, and is given by:

$$Q = 2 \pi f_0 L/R,$$

where R is the resistance of the antenna 2.

The integrated circuit area 4 is encapsulated by a tough UV (ultraviolet) adhesive 6, such as model number 35241 adhesive made by Loctite Inc. The adhesive is preferably applied by a programmable controlled automatic dispensing unit for providing consistent application of the adhesive to the integrated circuit area with components soldered thereon. An ink dam 9 is provided surrounding the integrated circuit area 4, for limiting the flow of encapsulation material. After applying the adhesive 6, the circuit board assembly is immediately placed under a UV lamp for curing. The profile of the encapsulation is as shown in Figure 2.

Application of the UV adhesive 6 over the component area 4 reinforces that area, so that it becomes "semi-rigid". According to the present invention, this area is made semi-rigid as opposed to substantially completely rigid, because the UV adhesive 6 which is chosen for the present invention has a limited degree of flexibility so that it will not crack or fracture under stress. It has been found through experimentation that the substrate 1 experiences the greatest stress and degree of flexing at

the edge of the semi-rigid area between the surface mount components in area 4 and the embedded antenna coil 2. Because of this, multiple connections 3 are utilized between the embedded antenna coil 2 and the sensing circuit disposed in area 4, in order to reduce the risk of failure should one of the connections fail due to excessive flexing.

After the UV adhesive 6 is applied and cured, a MylarTM protective film 7 is applied to the integrated circuit area 4 to compensate for any discontinuities or irregularities in the application of the UV adhesive 6. The MylarTM film 7 is rolled on to the encapsulated area and then cut with a rolled dye. The MylarTM film 7 also minimizes any sharp edges not covered by encapsulation by the UV adhesive. This minimizes the surface stress experienced by the tag, thereby allowing it to "slip" through the rollers and belts of a sorting machine. This is useful for the intended postal tag application of the preferred embodiment. Furthermore, in applications where static electricity build up is common, the MylarTM film or membrane 7 may be provided with a resistive coating having a surface resistivity of tens of mega-ohms per square inch, to reduce surface charge build up and decrease discharge current when discharge occurs.

Turning now to Figure 4, a schematic diagram is shown of a preferred embodiment of receiver/transmitter sensing circuitry fabricated on the integrated circuit area 4 of the tag. The physical layout of these circuit elements is shown in the expanded view of Figure 3.

The receive antenna section comprises an embedded antenna coil 2, tuning capacitors C1 and C2, a dual bi-directional diode clamp D1, and high sensitivity RF Schotky barrier diode D2.

Capacitors C1 and C2 are connected in parallel with the receive antenna 2 (i.e. interconnected antenna windings 2A and 2B). The values of capacitors C1 and C2 are selected based on the required receive signal

frequency, inductance value of antenna 2 and parasitic capacitance of the embedded antenna 2, as discussed above. In the presence of the desired low frequency excitation signal, electro-magnetic energy is coupled into the embedded antenna and the capacitors C1 and C2.

A dual bi-directional diode clamp D1 is placed in parallel with the receive antenna 2 to limit the signal amplitude. The signal is then half-wave rectified through diode D2, which is an RF Schotky barrier diode. The cathode of the diode D2 is connected to resistor R16. Because the resistance of diode D2 increases directly with temperature, resistor R16 is selected to be many times larger than the maximum resistance of diode D2, in order to ensure adequate signal levels at the input of amplifier U1A. According to the preferred embodiment shown in Figure 4, amplifier U1A is implemented as a MAX417ESA dual operational amplifier. The internal series capacitance of the MAX417ESA amplifier is approximately 2.0 pF. This capacitance combined with the high impedance input of U1A and the rectification provided by diode D2, results in peak voltage detection of the incoming signal. The resulting peak detected voltage is positive with respect to ground (minus the D2 forward voltage drop) and is completely dependent on the coupled energy from the incoming signal.

Resistors R14 and R15 are provided to compensate for variations in the voltage input offset characteristics of amplifiers U1A and U1B. According to the preferred embodiment illustrated, the MAX417ESA series dual operational amplifier has been found to consume excessive current when the difference in the two input voltages with respect to ground (the voltage between pins 2 and 3) is less than the characteristic input offset voltage for the amplifier. Nonetheless, the MAX417ESA dual operational amplifier was chosen in the preferred embodiment for its extremely low biasing current, which at the time of filing this application is apparently

unavailable from any other component.

Resistors R14 and R15 are configured in series across the supply voltage for providing a voltage divider network whereby one terminal of the embedded antenna coil 2 is referenced through the junction of the two resistors. Resistor R15 is selected such that the voltage drop across R15 causes a positive voltage differential between pins 2 and 3 of operational amplifier U1A that is greater than the input offset characteristic of U1A.

The resistors R2 and R3 surrounding operational amplifier U1A are used to configure the amplifier as a non-inverting amplifier with a gain of 10 in the preferred embodiment. D3 is a bidirectional diode clamp and is placed across the feedback resistor R3 for providing automatic gain control. D3 has an equivalent resistance, R_{D3} , of 480K ohms in the preferred embodiment. The amplifier gain is given by:

$$A_A = 1 + ((R_3 R_{D3} / (R_3 + R_{D3})) / R_2)$$

Capacitor C3 is connected from the output of U1A to the input of a band pass filter comprising the components R1, C14, R4, C15, R5, R17, R13 surrounding U1B, thereby creating a second order band pass filter with a gain of 16.5 and a passband of 80 Hz centred at 610 Hz. Capacitor C3 AC couples the signal from the first stage amplifier U1A to the second stage amplifier U1A to the second stage band pass filter. The amplifier gain is given by:

$$A_B = R_5 / 2R_1$$

The pass band is given by:

$$\Delta\omega = 2 / C_{15}R_5$$

The centre frequency is given by:

$$\omega_0 = \frac{1}{C_{15} \sqrt{R_5 \frac{R_1 R_2}{R_1 + R_4}}}$$

The two amplifiers U1A and U1B are cascaded together to provide a total gain of 165.5, as follows:

$$A_t = A_A \times A_B$$

The output of U1B is connected to capacitor C16 which couples the signal to a peak detector circuit comprising D6, C17 and R18. Dual diode D6 comprises two diodes, and when configured as per the preferred embodiment, conducts during the negative cycle of the amplified signal, hereby charging capacitor C16. During the negative cycle of the amplified signal, diode D6A does not conduct and therefore blocks negative current flow.

The positive charge accumulated across capacitor C16 is added to the signal on the next positive cycle of the detected signal effectively boosting the voltage that appears across capacitor C17. Resistor R6 is connected from the node of capacitor C17 and resistor R18 to the base of transistor Q1. When the resulting voltage across the peak detector circuit exceeds the turn on voltage of Q1 (which in the preferred embodiment, is at 0.45 volts) transistor Q1 turns on, thereby pulling the voltage across resistor R7 to ground. Thus, transistor Q1 operates as a switch. Transistor 43 is connected in parallel with Q1. Transistor 43 is a phototransistor that is specifically used for writing information into the microprocessor of the tag. When exposed to infrared light, transistor Q3 turns on. Information is sent to the tag by modulating the infrared light with encoded information.

The remaining portions of the circuitry shown in Figure 4, are substantially identical to the circuitry disclosed in applicant's co-pending U.S. application serial number 946,425 filed May 1, 1991, the subject matter of which is referenced here.

In summary, according to the present invention, a radio frequency identification tag is provided which is of robust, flexible design. The tag exhibits greater

efficiency, lower cost and lower weight than prior art designs, and is capable of withstanding considerable stresses experienced in applications such as mail efficiency processing measurement.

5 Other embodiments and variations of the invention are possible. For example, although the preferred embodiment is directed to radio frequency identification tag for mail sorting efficiency applications, the flexible substrate of the present invention with imbedded
10 antenna coil and adjacent semi-rigid circuit component area, may be utilized in different configurations for different applications such as inventory control, vehicle identification, etc. All such alternative embodiments and configurations are believed to be within the sphere
15 and scope of the claims as appended hereto.

THE EMBODIMENTS OF THE INVENTION IN WHICH AN EXCLUSIVE PROPERTY OF PRIVILEGE IS CLAIMED ARE DEFINED AS FOLLOWS:

1. A printed circuit comprising:
 - a) a flexible circuit board substrate;
 - b) an imbedded antenna coil of said flexible circuit board substrate;
 - c) an integrated circuit area adjacent said imbedded antenna coil for carrying circuit elements; and
 - d) electrical connection means between said antenna coil and said integrated circuit area, said antenna coil comprising a first winding printed on one side of said substrate and a second winding printed on an opposite side of said substrate, said first and second windings being connected together at one end through said substrate and to said electrical connection means at respective opposite ends thereof.
2. The printed circuit of claim 1, further comprising a layer of semi-rigid material encapsulating said integrated circuit area for strengthening said substrate in the event of flexing thereof.
3. The printed circuit of claim 2, further comprising a membrane laid over said layer of semi-rigid material, said flexible circuit board substrate with imbedded antenna coil and said electrical connection means, for providing a slip surface between said circuit elements.
4. The printed circuit of claim 1, wherein said flexible circuit board substrate is fabricated from epoxy glass laminate.

5. The printed circuit of claim 1 wherein said first and second windings are offset from each other to reduce parasitic capacitance therebetween.

6. The printed circuit of claim 1, wherein said electrical connection means comprises a plurality of electrically conducting traces deposited on said substrate.

7. The printed circuit of claim 1, further comprising gold plating applied to said antenna coil for increasing conductivity thereof.

8. The printed circuit of claim 3, further comprising a resistive coating deposited on said membrane for reducing electrostatic charge build-up and decreasing surface charge and discharge currents thereon.

9. A method of making an identification tag, the method comprising:

providing a flexible substrate having an antenna portion, an integrated circuit portion;

forming an antenna on the antenna portion of said substrate;

forming a sensing circuit on the integrated circuit portion of said substrate;

forming a connection between said sensing circuit and said antenna on said substrate,

said step of forming an antenna comprises:

forming a first winding on one side of said substrate;

forming a second winding on the opposite side of said substrate;

forming a single plated hole between said first and second winding; and

connecting said first and second windings together at one end through said substrate via the single plated hole.

10. A method of making an identification tag according to claim 9, wherein said method additionally comprises the step of encapsulating the sensing circuit to form a semi-rigid area on said substrate while said antenna portion remains flexible.

11. A method of making an identification tag according to claim 10 wherein the step of encapsulating the sensing circuit to form a semi-rigid area on said substrate includes:

applying an encapsulating material over said sensing circuit; and

curing said encapsulating material to form an encapsulation.

12. A method of making an identification tag according to claim 11 wherein the step of applying an encapsulating material over said sensing circuit includes the step of applying a UV adhesive over said sensing circuit, said UV adhesive having a limited degree of flexibility so that it will not crack or fracture under stress.

13. A method of making an identification tag according to claim 11 further comprising the step of forming an ink dam around said semi-rigid area to retain said encapsulating material within the semi-rigid area.

14. A method of making an identification tag according to claim 9 further comprising the step of applying a protective film over said antenna portion and said integrated circuit portion of said substrate.

15. A method of making an identification tag according to claim 14 wherein the step of applying a protective film over said antenna portion and said integrated circuit portion of said substrate comprises:

rolling a Mylar film onto the semi-rigid area; and
cutting said Mylar film with a rolled dye.

16. A method of making an identification tag according to claim 9 wherein the step of forming a second winding on a bottom side of said substrate includes offsetting the second winding from the first winding in order to minimize the parasitic capacities between the first and second windings.

17. A method of making an identification tag according to claim 9 further comprising the step of cutting out an excess portion of said substrate within the first and second windings.

18. A method of making an identification tag according to claim 9 wherein the step of forming a connection between said sensing circuit and said antenna on said substrate includes forming a plurality of parallel electrically conducting traces between said sensing circuit and said antenna so that in the event one of the traces becomes broken due to flexing of the substrate, another one of the traces will remain conducting.

19. A method of making an identification tag according to claim 9 further comprising tuning said antenna including the steps of:

measuring the inductance of said antenna;
measuring the capacitance of said antenna;
measuring the resistance of said antenna; and

coupling a capacitor in parallel with said antenna in order to tune the resulting circuit to resonate at a selected excitation frequency.

20. A printed circuit comprising:

a flexible circuit board substrate;

an imbedded antenna coil printed on said flexible circuit board substrate;

an integrated circuit area adjacent said imbedded antenna coil for carrying circuit elements; and

electrical connection means between said antenna coil and said integrated circuit area; said antenna coil comprising a first winding printed on one side of said substrate and a second winding printed on an opposite side of said substrate, said first and second windings being connected together at one end through said substrate and to said electrical connection means at respective opposite ends thereof, and traces of said first winding and traces of said second winding being offset from each other to reduce parasitic capacitance therebetween.

21. The printed circuit of claim 20, further comprising a layer of semi-rigid material encapsulating said integrated circuit area for strengthening said substrate in the event of flexing thereof.

22. The printed circuit of claim 21, further comprising a membrane laid over said layer of semi-rigid material, said flexible circuit board substrate with imbedded antenna coil and said electrical connection means, for providing a slip surface between said circuit elements.

23. The printed circuit of claim 20, 21, or 22 wherein said

flexible circuit board substrate is fabricated from epoxy glass laminate,

24. The printed circuit of claim 20, 21, 22, or 23 wherein said electrical connection means comprises a plurality of electrically conducting traces deposited on said substrate.

25. The printed circuit of claim 20, 21, 22, 23 or 24-, further comprising gold plating applied to said antenna coil for increasing conductivity thereof.

26. The printed circuit of claim 22, further comprising a resistive coating deposited on said membrane for reducing electrostatic charge build-up and decreasing surface charge and discharge currents thereon.

27. A method of making an identification tag, said method comprising:

 providing a flexible circuit board substrate having an antenna portion and an integrated circuit portion;

 forming an antenna on the antenna portion of said substrate;

 forming a sensing circuit on the integrated circuit portion of said substrate; and

 forming a connection between said sensing circuit and said antenna on said substrate, said step of forming an antenna comprises:

 forming a first winding on a top side of said substrate,

 forming a second winding, having traces offset with respect to traces of said first winding, on a bottom side of said substrate,

forming a single plated hole between said first and second winding, and connecting said first and second windings together at one end through said substrate via the single plated hole and to said electrical connection means at respective opposite ends thereof,

wherein said offset reduces parasitic capacitance therebetween.

28. The method of claim 2027, wherein said method additionally comprises the step of encapsulating the sensing circuit to form a semi-rigid area on said substrate while said antenna portion remains flexible.

29. The method of claim 28, wherein the step of encapsulating the sensing circuit to form a semi-rigid area on said substrate comprises applying an encapsulating material over said sensing circuit and curing said encapsulating material to form an encapsulation.

30. The method of claim 29, wherein the step of applying an encapsulating material over said sensing circuit includes the step of applying a UV adhesive over said sensing circuit, said UV adhesive having a limited degree of flexibility so that it will not crack or fracture under stress.

31. The method of claim 30, wherein said method further comprises the step of forming an ink dam around said semi-rigid area to retain said encapsulating material within the semi-rigid area.

32. The method of claim 2027, further comprising the step of applying a protective film over said antenna portion and said integrated circuit portion of said substrate.

33. The method of claim 32, wherein the step of applying a protective film over said antenna portion and said integrated circuit portion of said substrate comprises rolling a Mylar film onto the semi-rigid area and cutting said Mylar film with a rolled dye.

34. The method of claim ~~20~~27, further comprising the step of cutting out an excess portion of said substrate in the center of the first and second windings.

35. The method of claim 27, wherein the step of forming a connection between said sensing circuit and said antenna on said substrate includes forming a plurality of parallel electrically conducting traces between said sensing circuit and said antenna so that in the event one of the traces becomes broken due to flexing of the substrate, another one of the traces will remain conducting.

36. The method of claim ~~20~~27 further comprising the steps of
measuring the inductance of said antenna;
measuring the capacitance of said antenna;
measuring the resistance of said antenna; and
coupling a capacitor in parallel with said antenna in order to tune the resulting circuit to resonate at a selected excitation frequency.

37. A printed circuit adapted for RF identification and processing through sorting apparatus, the printed circuit comprising:

a) a single thin layer of flexible circuit board fabricated from epoxy glass laminate and having a cutout window in a first area;

b) an imbedded antenna coil printed on at least one side of the first area of said flexible circuit board around a perimeter of the cutout window;

c) an integrated circuit mounted on top of a second area of said flexible circuit board substrate laterally adjacent said imbedded antenna coil for carrying circuit elements;

d) electrical connection means extending laterally between the first area and the second area to connect electrically said antenna coil and said integrated circuit;

e) a layer of semi-rigid material encapsulating only said integrated circuit in the second area having a limited degree of flexibility which is less than a degree of flexibility of the substrate; and

f) a membrane laid over said layer of semi-rigid material, said flexible circuit board substrate with imbedded antenna coil and said electrical connection means, providing a slip surface over said circuit elements.

38. The printed circuit of claim 37, wherein said antenna coil comprises a first winding printed on one side of said substrate, and a second winding printed on an opposite side of said substrate, said first and second windings being connected together at one end through said substrate and to said electrical connection means at respective opposite ends thereof.

39. The printed circuit of claim 38 wherein said first and second windings are offset from each other to reduce parasitic capacitance therebetween.

40. The printed circuit any one of claims 37-39, wherein said electrical connection means comprises a plurality of electrically conducting traces deposited on said substrate.

41. The printed circuit any one of claims 37-39, further comprising gold plating applied to said antenna coil for increasing conductivity thereof.

42. The printed circuit of any one of claims 37-39, further comprising a resistive coating deposited on said membrane for reducing electrostatic charge build-up and decreasing surface charge and discharge currents thereon.

43. The printed circuit board any one of claims 37-39, wherein said layer of semi-rigid material comprises UV adhesive.

44. The printed circuit board of claim 43, wherein the UV adhesive provides a limited degree of flexibility to prevent cracking and fracturing of the adhesive under stresses administered by automated postal equipment.

45. The printed circuit board any one of claims 37-39, wherein said integrated circuit area houses a plurality of electrical and electronic components in one portion thereof connected to a battery in another portion thereof.

46. The printed circuit board any one of claims 37-39, wherein the total weight of the printed circuit board does not exceed approximately 6.0 g.

47. The printed circuit board any one of claims 37-39, wherein the substrate has a core thickness of approximately 8 mils.

48. The printed circuit any one of claims 37-39, wherein a battery to power said printed circuit is provided adjacent said integrated circuit, said battery being connected to said imbedded antenna coil and said integrated circuit.

49. A printed lightweight circuit comprising:

a) a single body portion comprising a single rectangular thin layer of flexible circuit board having a cutout window in a first area of said circuit board;

b) an imbedded antenna coil embedded on the first area of said flexible circuit board comprising a first winding printed on one side of said circuit board and a second winding printed on an opposite side of said circuit board, said windings being offset from each other to reduce parasitic capacitance there between, wherein said antenna coil is printed around the perimeter of said hole in said substrate and first area of the circuit board;

c) an integrated circuit mounted on top of a second area of said flexible circuit board adjacent said imbedded antenna coil for carrying circuit elements;

d) electrical connection means between said antenna coil and said integrated circuit area, said electrical connection means comprising a plurality of electrically conducting traces deposited on said circuit board;

e) a layer of semi-rigid material encapsulating only said integrated circuit in the second area having a limited degree of flexibility which is less than a degree of flexibility of the circuit board;

f) membrane laid over said layer of semi-rigid material, said flexible circuit board with imbedded antenna coil and said electrical connection means, for providing a slip surface on said circuit elements; and

g) a resistive coating deposited on said membrane for reducing electrostatic charge build-up and decreasing surface charge and discharge currents thereon.

50. A printed circuit adapted for radio frequency identification and arranged to be sufficiently durable and resilient for processing through sorting apparatus comprising rollers and belts, the printed circuit comprising:

- a) single thin layer of flexible circuit board;
- b) an imbedded antenna coil printed on at least one side of a first area of said flexible circuit board;
- c) an integrated circuit mounted on top of a second area of said flexible circuit board and adjacent said imbedded antenna coil for carrying circuit elements;
- d) electrical connection means between said antenna coil and said integrated circuit area; and
- e) a layer of semi-rigid material encapsulating only said integrated circuit in the second area having a limited degree of flexibility which is less than a degree of flexibility of the circuit board; and
- f) a polyester film membrane laid over said layer of semi-rigid material, said flexible circuit board with imbedded antenna coil and said electrical connection means, for providing a slip surface over said circuit elements.

51. The printed circuit of claim 50 in which the circuit board is fabricated from epoxy glass laminate and the semirigid material is formed of UV adhesive encapsulation material.

52. The printed circuit of any one of claims 50 or 51 in which the first area of the flexible circuit board includes a cutout window in a central portion thereof and the embedded antenna coil is printed around a perimeter of the window.

53. A printed lightweight circuit adapted for radio frequency identification and arranged to be sufficiently durable and resilient for processing through sorting apparatus comprising rollers and belts, the printed circuit comprising:

a) a single rectangular thin layer of flexible circuit board having a cutout window in a first area of said circuit board;

b) an imbedded antenna coil embedded on a first area of said flexible circuit board comprising a first winding printed on one side of said circuit board and a second winding printed on an opposite side of said circuit board, said windings being offset from each other to reduce parasitic capacitance there between, wherein said antenna coil is printed around the perimeter of said cutout window;

c) an integrated circuit mounted on top of a second area of said flexible circuit board and adjacent said imbedded antenna coil for carrying circuit elements;

d) electrical connection means between said antenna coil and said integrated circuit area, said electrical

connection means comprising a plurality of electrically conducting traces deposited on said substrate; and

e) a layer of semi-rigid material encapsulating only said integrated circuit in the second area having a limited degree of flexibility which is less than said degree of flexibility of the substrate; and

f) a membrane laid over said layer of semi-rigid material, said flexible circuit board with imbedded antenna coil and said electrical connection means, for providing a slip surface over said circuit elements.

54. The printed lightweight circuit of claim 53 additionally comprising

a resistive coating deposited on said membrane for reducing electrostatic charge build-up and decreasing surface charge and discharge currents thereon.

55. The printed circuit of claims 53 or 54 which the antenna has a gold plating applied thereto for increasing the conductivity thereof.

56. The printed circuit any one of claims 53-55 in which the circuit board is fabricated from epoxy glass laminates, the semirigid material is formed of UV adhesive encapsulation material; and the membrane is formed by a thin polyester film material.

57. A printed circuit comprising:

a) a single layer of flexible circuit board substrate having a degree of flexibility capable of withstanding stresses experienced in mail processing equipment;

b) an imbedded antenna coil printed on at least one side of said flexible circuit board substrate;

c) an integrated circuit area on said flexible circuit board substrate and adjacent said imbedded antenna coil for carrying circuit elements;

d) electrical connection means between said antenna coil and said integrated circuit area;

e) a layer of semi-rigid material encapsulating only said integrated circuit area for providing a limited degree of flexibility to said integrated circuit area of said substrate which is less than said degree of flexibility of said substrate;

f) a membrane laid over said layer of semi-rigid material, said flexible circuit board substrate with imbedded antenna coil and said electrical connection means for providing a slip surface to the entire surface of the printed circuit; and

g) a resistive coating deposited on said membrane for reducing electrostatic charge build-up and decreasing surface charge and discharge currents thereon.

58. The printed circuit of claim 57, wherein said antenna coil comprises a first winding printed on one side of said substrate, and a second winding printed on an opposite side of said substrate, said first and second windings being connected together at one end through said substrate and to said electrical connection means at respective opposite ends thereof.

59. The printed circuit of claim 58, wherein said first and second windings are offset from each other to reduce parasitic capacitance therebetween.

60. The printed circuit any one of claims 57-59, wherein said electrical connection means comprises a plurality of electrically conducting traces deposited on said substrate.

61. The printed circuit any one of claims 57-59, further comprising gold plating applied to said antenna coil for increasing conductivity thereof.

62. The printed circuit board any one of claims 57-59, wherein said layer of semi-rigid material comprises UV adhesive.

63. The printed circuit board of claim 62, wherein the UV adhesive provides a limited degree of flexibility to prevent cracking and fracturing of the adhesive under stresses administered by automated postal equipment.

64. The printed circuit board any one of claims 57-59, wherein said integrated circuit area houses a plurality of electrical and electronic components in one portion thereof connected to a battery in another portion thereof.

65. The printed circuit board any one of claims 57-59, wherein the total weight of the printed circuit does not exceed approximately 5.0 to 6.0 g.

66. The printed circuit board any one of claims 57-59, wherein the core thickness of said single layer of substrate is approximately 8 mils.

67. The printed circuit board any one of claims 57-59, wherein there is provided a hole in a portion of said flexible circuit board substrate.

68. The printed circuit board of claim 67, wherein said imbedded antenna coil is printed along the perimeter of said hole in said flexible circuit board substrate.

69. A printed circuit comprising:

a) a single layer of flexible circuit board substrate having a degree of flexibility capable of withstanding stresses experienced in mail processing equipment;

b) an imbedded antenna coil printed on at least one side of said flexible circuit board substrate;

c) an integrated circuit area on said flexible circuit board substrate and adjacent said imbedded antenna coil for carrying circuit elements;

d) electrical connection means between said antenna coil and said integrated circuit area comprising a plurality of electrically conducting traces deposited on said substrate;

e) a layer of semi-rigid material encapsulating only said integrated circuit area for providing a limited degree of flexibility to said integrated circuit area of said substrate which is less than said degree of flexibility of said substrate;

said antenna coil comprising a first winding printed on one side of said substrate, and a second winding printed on an opposite side of said substrate, said first and second windings being connected together at one end through said

substrate and to said electrical connection means at respective opposite ends thereof.

70. The printed circuit board of claim 69, wherein said imbedded antenna coil is printed along a perimeter of a hole in said flexible circuit board substrate.

71. The printed circuit board of claims 69 or 70, wherein said integrated circuit area houses a plurality of electrical and electronic components in one portion thereof connected to a battery in another portion thereof.

72. A printed circuit comprising:

a) a single layer of flexible circuit board substrate having a degree of flexibility capable of withstanding stresses experienced in mail processing equipment;

b) an imbedded antenna coil printed on at least one side of said flexible circuit board substrate;

c) an integrated circuit area on said flexible circuit board substrate and adjacent said imbedded antenna coil for carrying circuit elements;

d) electrical connection means between said antenna coil and said integrated circuit area;

e) a layer of semi-rigid material encapsulating only said integrated circuit area for providing a limited degree of flexibility to said integrated circuit area of said substrate which is less than said degree of flexibility of said substrate;

wherein said integrated circuit area houses a plurality of electrical and electronic components in one portion thereof connected to a battery in another portion thereof.

73. The printed circuit board of claim 72, wherein said imbedded antenna coil is printed along a perimeter of a hole in said flexible circuit board substrate.

74. A method of making a flexible identification tag capable of withstanding considerable stresses experienced in mail processing equipment, the method comprising:

providing a single layer of a flexible substrate having an antenna portion, and an integrated circuit portion;

forming an antenna on the antenna portion of said substrate wherein said antenna is formed over substantially most of said flexible substrate;

forming a sensing circuit on the integrated circuit portion of said substrate, wherein said sensing circuit is formed in an area of said substrate separate and adjacent to said antenna portion;

forming a connection between said sensing circuit and said antenna of said substrate;

encapsulating the sensing circuit to form a semi-rigid area on said substrate while said antenna portion remains flexible; and

forming an ink dam around said semi-rigid area to retain said encapsulating material within said semi-rigid area.

75. A method of making an identification tag according to claim 74 wherein the step of encapsulating the sensing circuit to form a semi-rigid area on said substrate includes:

applying an encapsulating material over said sensing circuit; and

curing said encapsulating material to form an encapsulation.

76. A method of making an identification tag according to claim 75 wherein the step of applying an encapsulating material over said sensing circuit includes the step of applying a UV adhesive over said sensing circuit, said UV adhesive having a limited degree of flexibility so that it will not crack or fracture under stress.

77. A method of making an identification tag according to any one of claims 74-76 further comprising the step of applying a protective film over said antenna portion and said integrated circuit portion of said substrate.

78. A method of making an identification tag according to claim 77 wherein the step of applying a protective film over said antenna portion and said integrated circuit portion of said substrate comprises:

rolling a Mylar.TM. film onto the semi-rigid area; and

cutting said Mylar.TM. film with a rolled die.

79. A method of making an identification tag according to any one of claims 74-77 wherein the step of forming an antenna on a first portion of said substrate includes:

forming a first winding on a top side of said substrate;
forming a second winding on a bottom side of said
substrate; and

forming a single plated hole between said first and
second windings.

80. A method of making an identification tag according to
claim 79 wherein the step of forming a second winding on a
bottom side of said substrate includes offsetting the second
winding from the first winding in order to minimize the
parasitic capacitances between the first and second windings.

81. A method of making an identification tag according to
claim 79 further comprising the step of cutting out an excess
portion of said substrate within the first and second
windings.

82. A method of making an identification tag according to any
one of claims 74-81 wherein the step of forming a connection
between said sensing circuit and said antenna on said
substrate includes forming a plurality of parallel
electrically conducting traces between said sensing circuit
and said antenna so that in the event one of the traces
becomes broken due to flexing of the substrate, another one of
the traces will remain conducting.

83. A method of making an identification tag according to any
one of claims 74-81 further comprising tuning said antenna
including the steps of:

measuring the inductance of said antenna;

measuring the capacitance of said antenna;

measuring the resistance of said antenna; and

coupling a capacitor in parallel with said antenna in order to tune the resulting circuit to resonate at a selected excitation frequency.

84. A method of making an identification tag according to any one of claims 74-81 including applying a protective film by rolling a Mylar.TM. film onto the entire flexible circuit board substrate including over the encapsulated area containing the sensing circuit, the antenna, and the connection therebetween, and cutting the Mylar.TM. film with a rolled die.

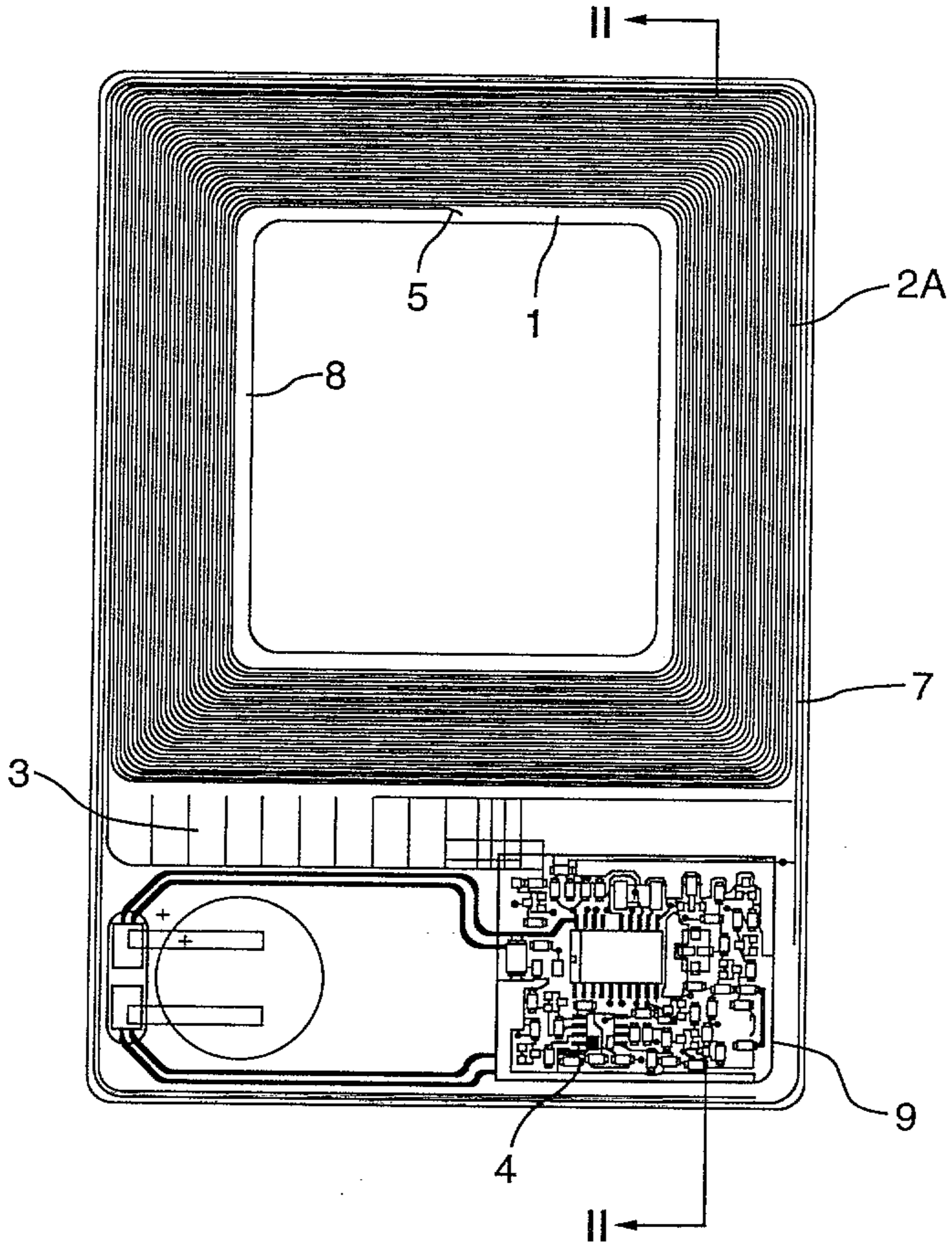

FIG.1A.

Samuel M. Burns

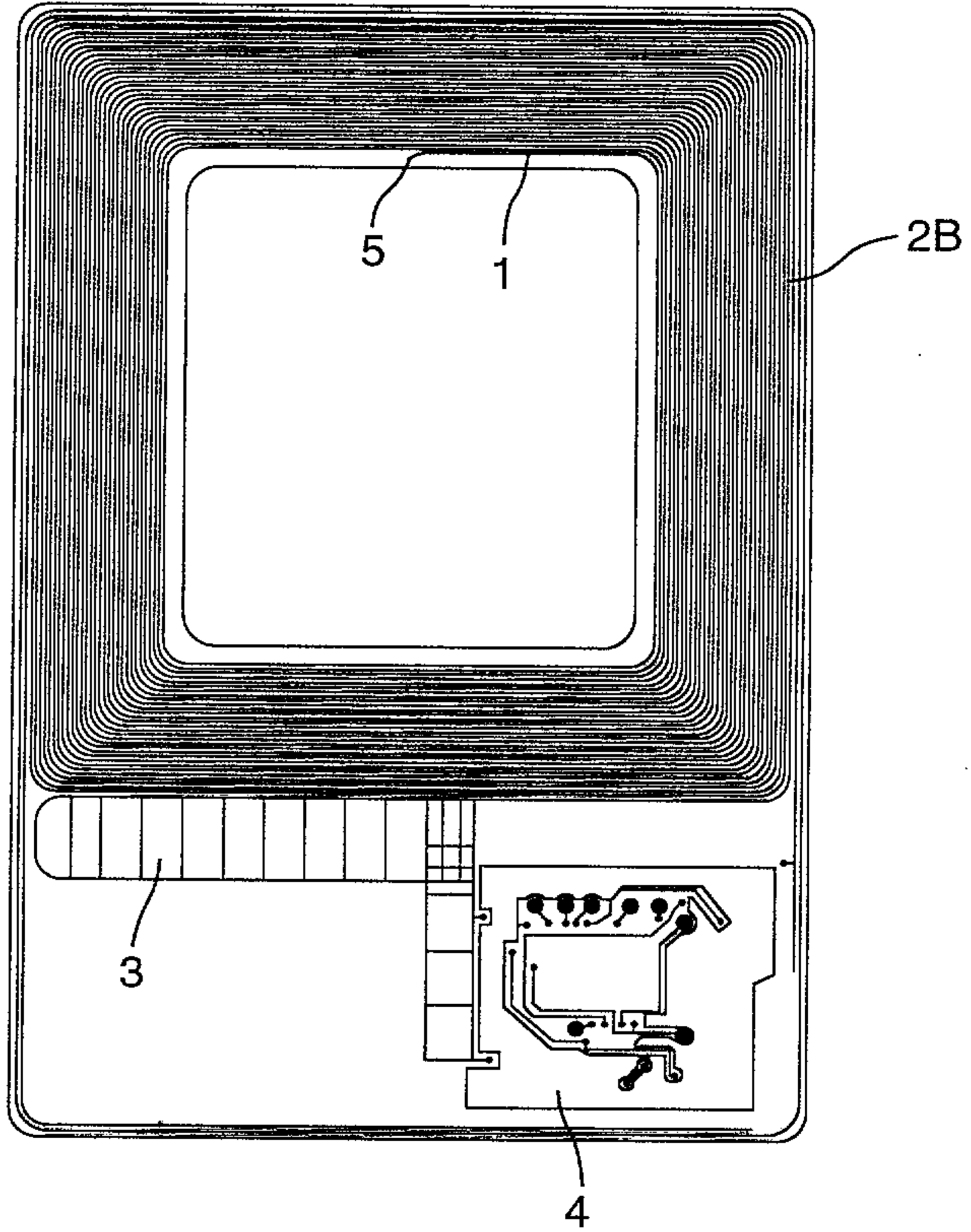

FIG. 1B.

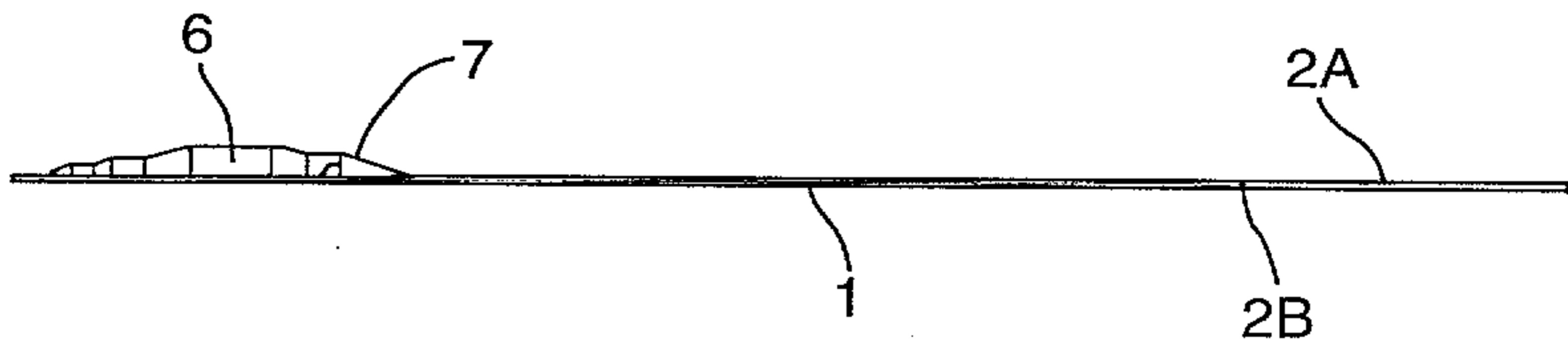

FIG. 2.

Simon M. Lerner

2176625

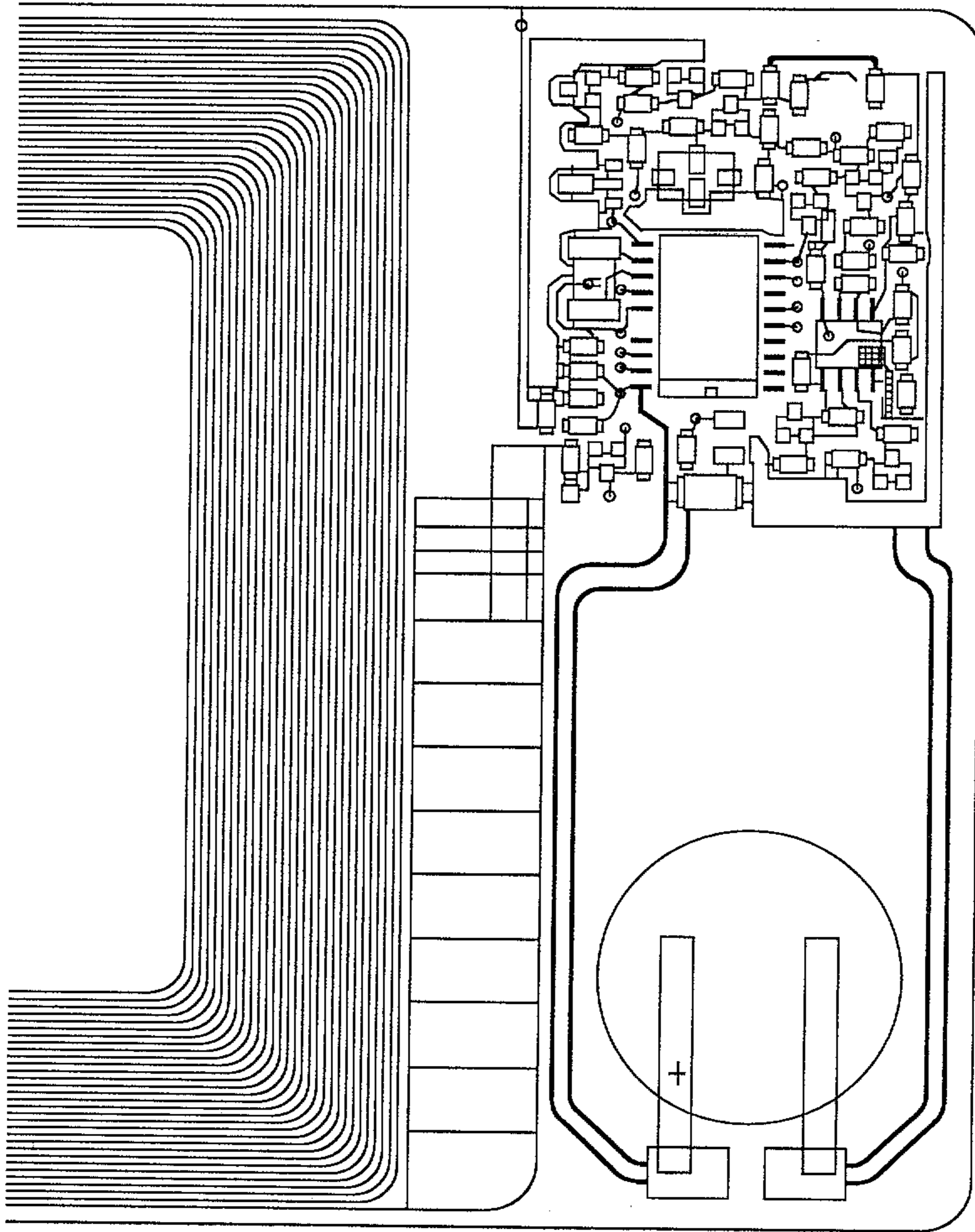

FIG. 3.

Sim. J. L. Luning

2176625

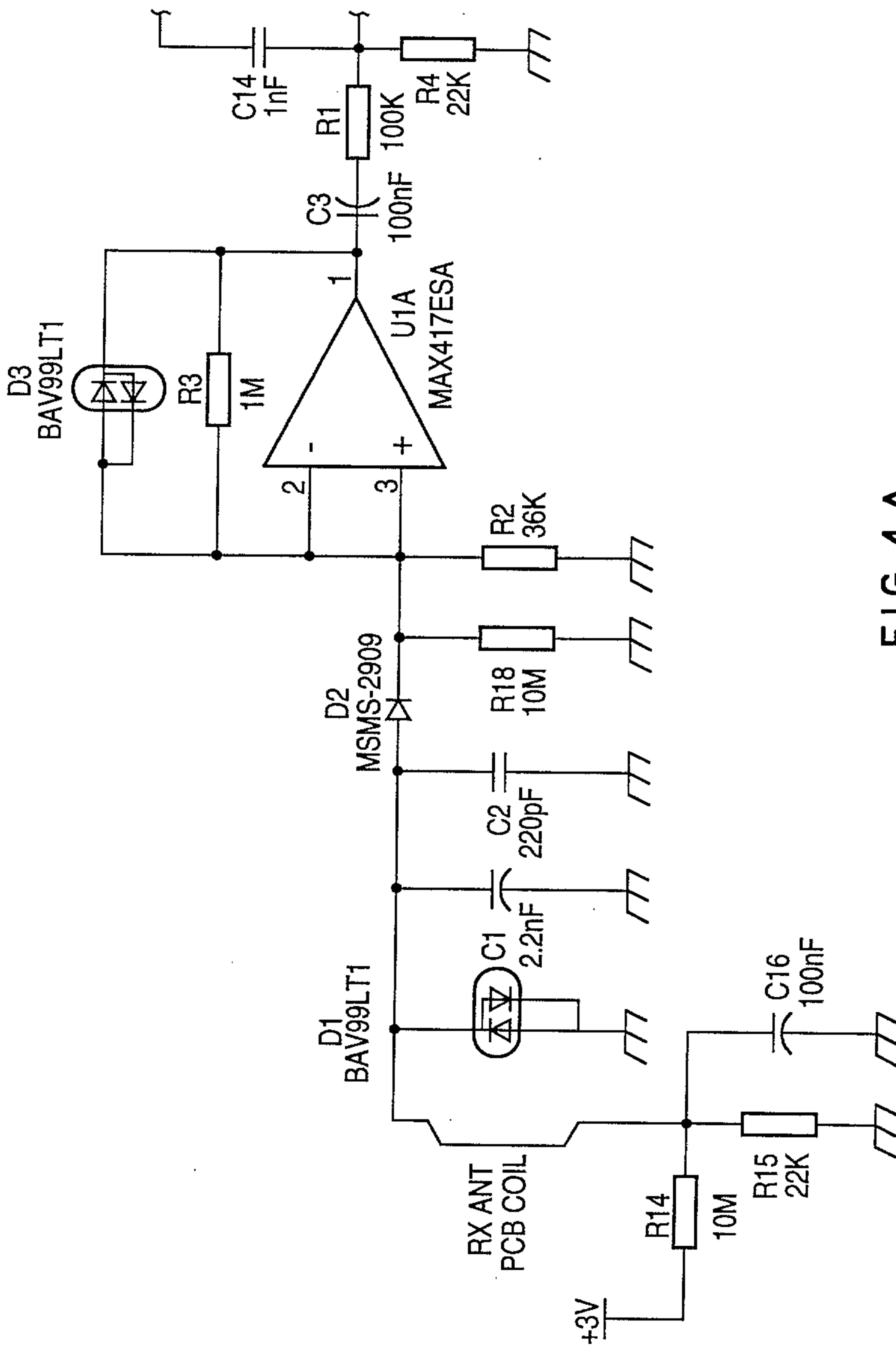
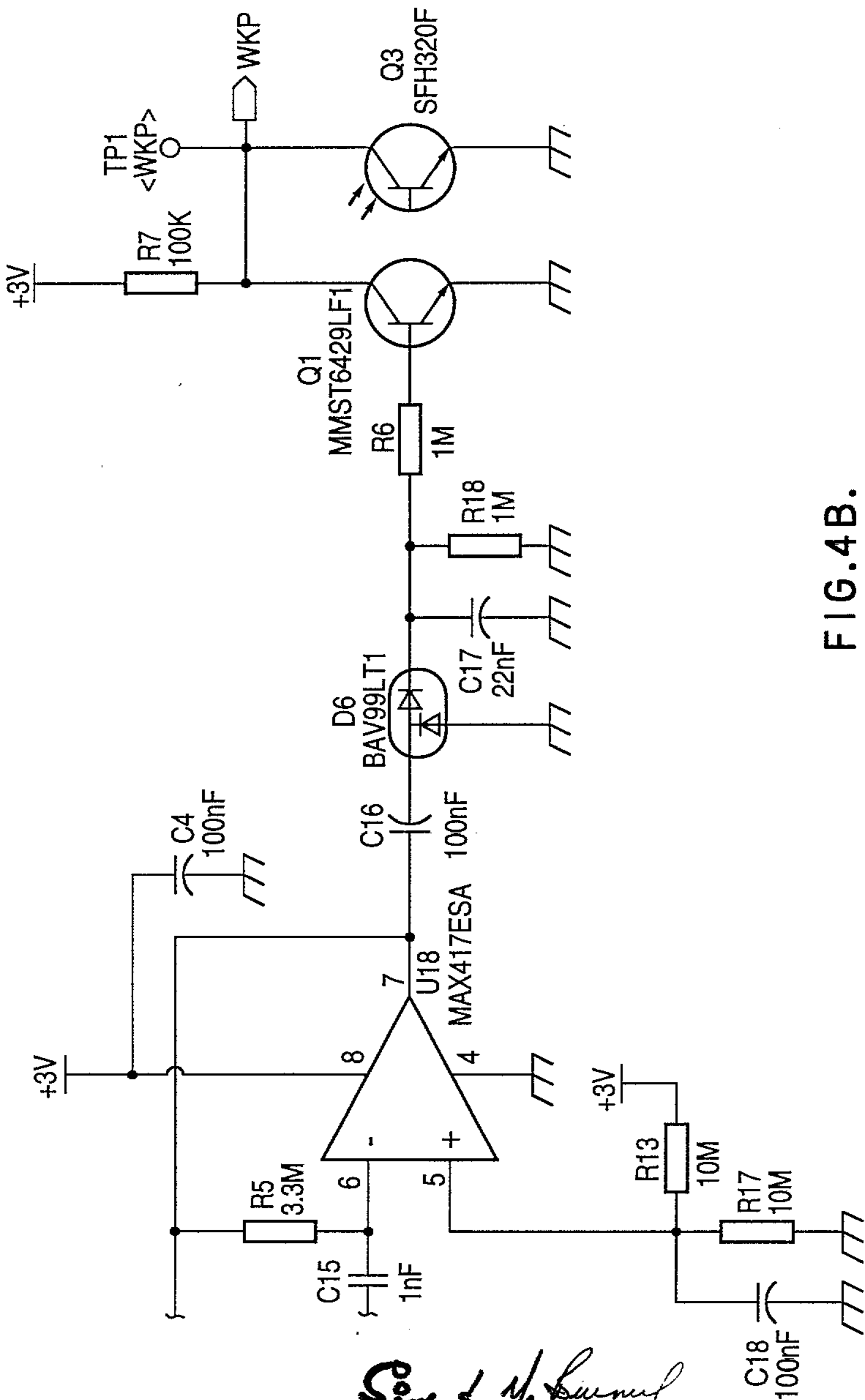

FIG.4 A.

Sim, M. S. S. S.



Sim. M. Luenig

FIG. 4B.

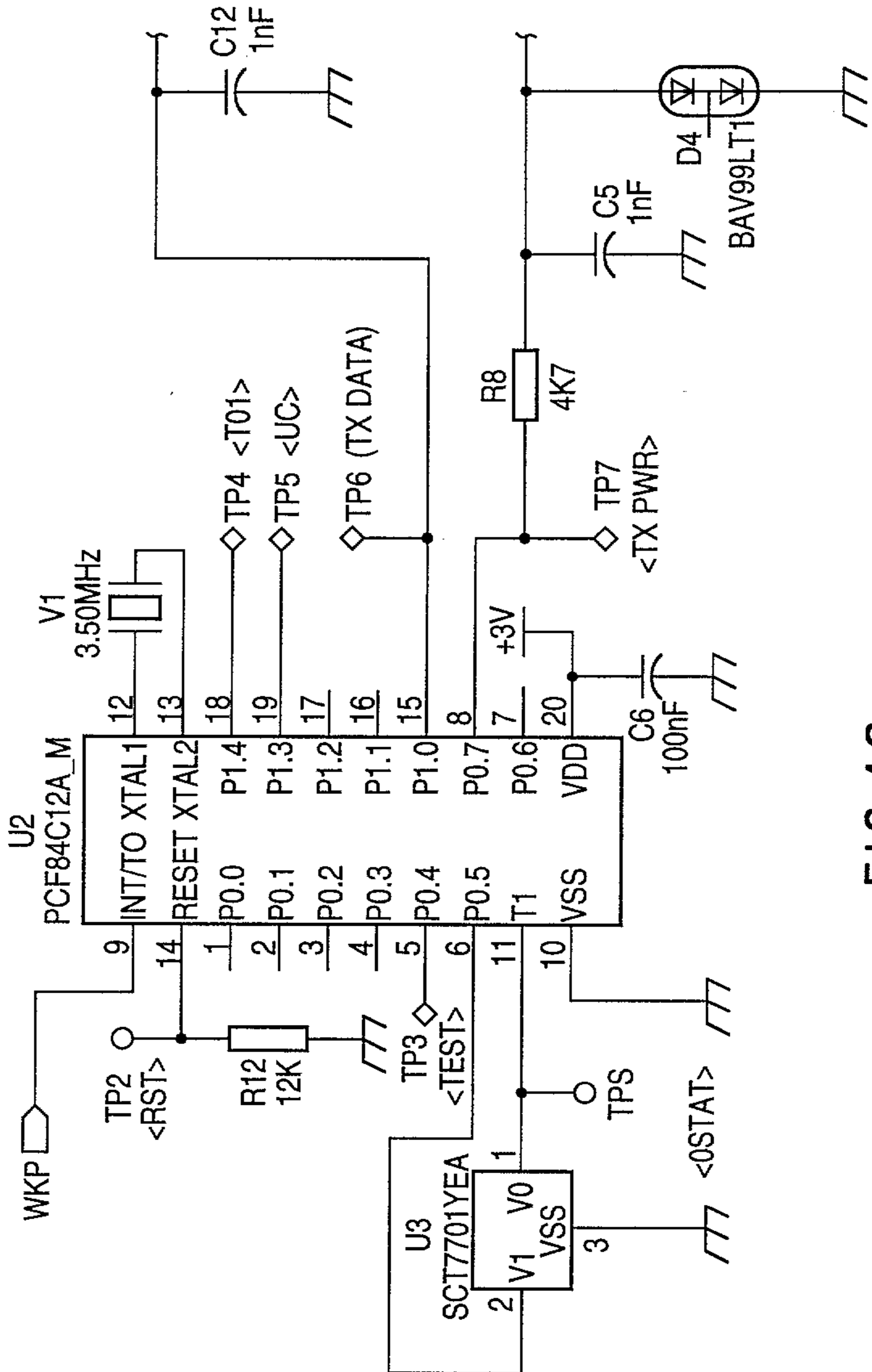

FIG.4C.

Sim. M. Kumar

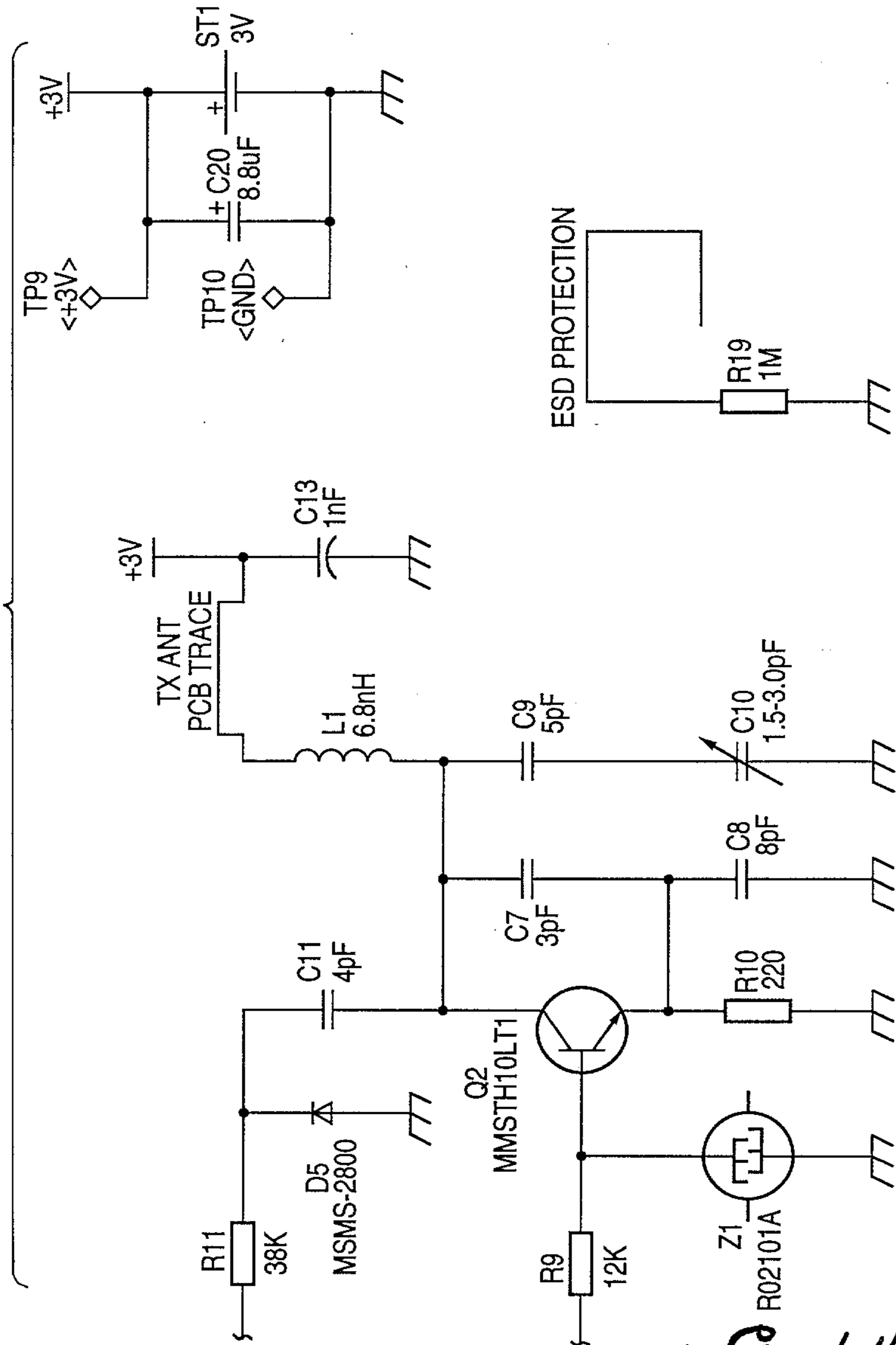

FIG.4D.

Handwritten signature and initials

