

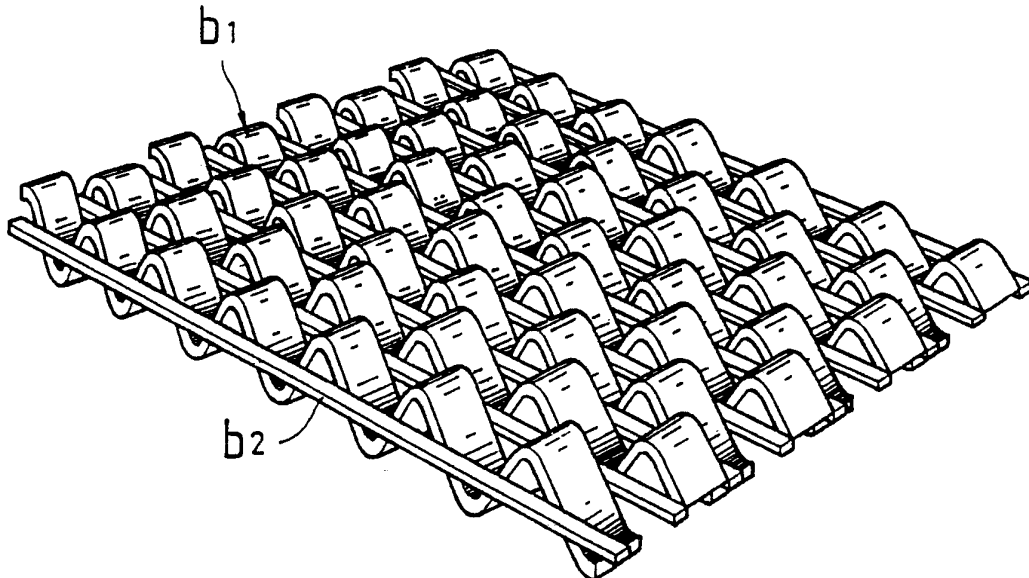

INTERNATIONAL APPLICATION PUBLISHED UNDER THE PATENT COOPERATION TREATY (PCT)

<p>(51) International Patent Classification ⁵ : A47L 23/22, A47G 27/02</p>	A1	<p>(11) International Publication Number: WO 92/11798 (43) International Publication Date: 23 July 1992 (23.07.92)</p>
<p>(21) International Application Number: PCT/KR91/00033 (22) International Filing Date: 20 December 1991 (20.12.91) (30) Priority data: 90-21958 27 December 1990 (27.12.90) KR (71) Applicant (for all designated States except US): LUCKY, LTD. [KR/KR]; 20, Yoido-dong, Youngdungpo-gu, Seoul 150-010 (KR). (72) Inventors; and (75) Inventors/Applicants (for US only) : KIL, Kee, Sung [KR/KR]; A-301, Lucky Apt., Pongmyung-dong, Cheongju-si, Choongchungbuk-do 360-300 (KR). WHANG, Woon, Hyun [KR/KR]; 109-402, Chookong Apt., Pongmyung-dong, Cheongju-si, Choongchungbuk-do 360-300 (KR). LEE, Kang, Youp [KR/KR]; 221-13, Pongmyung-dong, Cheongju-si, Choongchungbuk-do 360-300 (KR).</p>		<p>(74) Agent: KIM, Yoon, Bae; Y.B. Kim, Lees & Associates, 7th Floor, Garden Tower Bldg., 98-78, Unni-dong, Jongro-gu, Seoul 110-350 (KR). (81) Designated States: AT (European patent), AU, BE (European patent), CH (European patent), DE (European patent), DK (European patent), ES (European patent), FR (European patent), GB (European patent), GR (European patent), IT (European patent), JP, LU (European patent), MC (European patent), NL (European patent), SE (European patent), US. Published With international search report.</p>

(54) Title: DOORMAT AND APPARATUS FOR PRODUCING THE SAME



(57) Abstract

The present invention relates to a doormat and an apparatus for producing the same. In particular, the doormat according to the present invention eliminates well mark from the outsole of shoes because of its good restoring force and elasticity, is convenient to use, may prevent slip because convexities formed on the surface of corrugated band are different from each other and has cushiony effect by space due to bend of synthetic resin sheet when people coming and going step on the above doormat laid on a door or a gate. The apparatus for preparing the above doormat comprises simple structure and is used in preparing easily the above doormat. Also, the above doormat comprises only plural and continuous corrugated bands (b₁), or the corrugated bands (b₁) are combined alternately with the straight bands (b₂) to form holes in order to remove easily water.

FOR THE PURPOSES OF INFORMATION ONLY

Codes used to identify States party to the PCT on the front pages of pamphlets publishing international applications under the PCT.

AT	Austria	ES	Spain	MG	Madagascar
AU	Australia	FI	Finland	ML	Mali
BB	Barbados	FR	France	MN	Mongolia
BE	Belgium	GA	Gabon	MR	Mauritania
BF	Burkina Faso	GB	United Kingdom	MW	Malawi
BG	Bulgaria	GN	Guinea	NL	Netherlands
BJ	Benin	GR	Greece	NO	Norway
BR	Brazil	HU	Hungary	PL	Poland
CA	Canada	IT	Italy	RO	Romania
CF	Central African Republic	JP	Japan	RU	Russian Federation
CG	Congo	KP	Democratic People's Republic of Korea	SD	Sudan
CH	Switzerland	KR	Republic of Korea	SE	Sweden
CI	Côte d'Ivoire	LI	Liechtenstein	SN	Senegal
CM	Cameroon	LK	Sri Lanka	SU	Soviet Union
CS	Czechoslovakia	LU	Luxembourg	TD	Chad
DE	Germany	MC	Monaco	TG	Togo
DK	Denmark			US	United States of America

Doormat and apparatus for producing the same

Technical Field

5 The present invention relates to a doormat and an apparatus for producing the same. In particular, it relates to a doormat which has good cushiony effect by space due to corrugation of synthetic resin sheet when people coming and going step on it laid on a door or a gate, eliminates well muck from the outsole of shoes because of its good restoring force and elasticity, is also convenient to
10 use and may prevent slip because of various convexities formed on the surface of corrugated band, and to an apparatus which comprises simple structure and is used in preparing easily the above doormat.

Background of the Art

 Various kinds of doormats have been used because a room was stained with muck
15 adhered to the outsole of shoes in the case of entering a room with stained shoes.

 Up to date, metallic coil spring bonded in a state of sheet or pile has been used as a doormat. Recently, the synthetic resin was extruded in a fine fiber, and then the fibers got tangled with each other irregularly in a state of coil, the sheet obtained was used as a doormat. Among them, the doormat made of
20 metallic coil spring easily eliminated muck adhered to the outsole of shoes.

 Such metallic doormat, however, had a disadvantage that it was difficult to shake fine muck from boots since scrapable effect was reduced by crushing of metallic coil spring in using doormat. Other disadvantage was that it had poor feeling by hardness. Also, the doormat made of pile had disadvantages that it was
25 inconvenient in wetting and therefore it had to be dry, furthermore, it could hardly eliminate muck. Also, although the third doormat eliminated well muck

adhered to the outsole of shoes, which muck in aperture of coil irregularly tangled was hardly eliminated.

Summary of the Invention

Accordingly, the object of the present invention is to provide the doormat
5 having excellent cushiony effect due to space formed by corrugation of synthetic resin sheet so as to solve the above problems of the doormats.

Other object of the present invention is to provide the doormat having effect to eliminate excellently muck adhered to the outsole of shoes because of its good restoring force and elasticity.

10 Another object of the present invention is to provide the apparatus which comprises simple structure and may easily prepare the above doormat.

Brief Description of the Figure

Figure 1 is a perspective view of the doormat according to the present invention.

15 Figure 2 is a side view of the above doormat.

Figure 3 is a plane view of the above doormat.

Figure 4 is a front view of the above doormat.

Figure 5 is an alternative embodiment of the doormat according to the present invention.

20 Figure 6 is a side view of the doormat represented in figure 5.

Figure 7 is a plane view of the doormat represented in figure 5.

Figure 8 is a front view of the doormat represented in figure 5.

Each (A), (B), (C) and (D) of figure 9 is a plane view of the doormat prepared by band having various convexities on the surface thereof.

25 Figure 10 is a schematic view of the apparatus for preparing the doormat according to the present invention.

Figure 11 is a plane view of the roller of the above apparatus.

Figure 12 is a plane view of the alternative roller of the above apparatus.

Detailed Description

The synthetic resin composition formed into the doormat according to the present invention must be composed of the materials which have excellent waterproofing, wear resistance, soluble property, elasticity and the likes. The example of organic polymers having such characteristics are polyvinyl chlorides, polyesters, polyurethanes, polypropylenes, polyethylenes, polystyrenes and various synthetic rubber.

The illustrations in figure 1 to figure 12 more clearly show the preferred embodiment of the present invention.

As illustrated in figure 1 which is a perspective view of the doormat according to the present invention, the plural and continuous bands (b_1) having 1 to 5mm of thickness and 2 to 20mm of width are combined alternately with the straight bands (b_2) having 0.2 to 5mm of thickness and 2 to 20mm of width, or only the corrugated bands (b_1) are combined in different phases to give the doormat of the figure 1.

Figure 2 is a side view of the above doormat, a corrugated band has different phase against next corrugated band and such corrugated bands having different phases with each other are combined alternately. As a result, holes are formed in space between the corrugated band (b_1) and the straight band (b_2).

Accordingly, the space due to phase difference of the above corrugated bands (b_1) gives us good cushiony effect so that feeling is good at stepping on the above doormat. Also, since it has good restoring force and elasticity, muck adhered to the outsole of shoes is easily removed.

Figure 3 is a plane view of the above doormat and figure 4 is a front view of

the above doormat.

Figure 5 is an alternative embodiment of the doormat according to the present invention. Since a width (h_1) of the corrugated band (b_1) may be differ from other width (h_2) thereof, bending and stretching force is distributed.

5 Accordingly, the doormat has better good feeling in use and it is fashionable because of graceful external appearance.

Each figure 6, figure 7 and figure 8 is a side view, a plane view and a front view of the doormat represented in figure 5,

Also, figure 9 is an alternative embodiment of the doormat according to the present invention. Since A of figure 9 represents that convexities (d_1) are horizontally formed on the surface of corrugated band (b_1) and B represents that another convexities (d_2) are longitudinally formed on the surface of corrugated band (b_1). Also, C represents that convexities (d_3) are formed in all directions on the surface of corrugated band (b_1) and D represents that dotted convexities
15 such as the surface of orange are irregularly formed. Therefore, slip is prevented at trampling the corrugated band (b_1) in using the doormat.

Therefore, the above doormats have good cushiony effect by space due to corrugation of synthetic resin sheet. Also, it eliminates well muck from the outsole of shoes because of its good restoring force and elasticity. Furthermore,
20 it is convenient and may prevent slip because of various convexities formed on the surface of the corrugated bands.

Figure 10 is a schematic view of an apparatus for preparing the doormat according to the present invention. The synthetic resin sheet (8) formed from extrusion dice(1) passes between rollers(2, 3) having the plural protuberances(4, 4') in the lower part of extrusion dice(1), and then it is molded into corrugated
25 shape. Next, it passes by guide roller(6) to take up by take-up roller(7).

Also, figure 11 is a plane view of the roller of the above apparatus.

As illustrated in figure 11 which is a plane view of the roller, the drive roller(2) having plural corrugated protuberances (4) is meshed with the idle roller(3) having plural corrugated protuberances (4') in the lower part of
5 extrusion dice(1). In the case that the drive roller(2) is rotated, the idle roller(3) is also rotated in attendance on rotation of the drive roller(2).

Walls(5, 5') are optionally established between protuberances and a corrugated protuberance(4) formed on the drive roller (2) crosses with the corrugated protuberance(4') formed on the idle drive(3). Since the guide roller(6) is
10 placed near rollers(2, 3), the synthetic resin sheet passed by the guide roller (6) is taken up by take-up roller(7).

Figure 12 is a plane view of the alternative roller of the above apparatus.

The drive roller(2') having plural corrugated protuberances(4'') is meshed with the idle roller(3') having plural corrugated protuberances(4''') in the lower part
15 of extrusion dice(1). In the case that the drive roller(2') is rotated, the idle roller(3') is also rotated in attendance on rotation of the drive roller (2').

Also, a corrugated protuberance(4'') formed on the drive roller(2') crosses with the corrugated protuberance (4''') formed on the drive roller(3'). Since the
guide roller(6) is placed near rollers(2', 3'), the synthetic resin sheet passed
20 by the guide roller(6) is taken up by take-up roller(7).

The doormat prepared by the above process may be cut in optional size according to use. The structure of apparatus for preparing the above doormat is very simple and the process for preparing the doormat is also easy in the case of
use the above apparatus. Accordingly, efficiency of work can be accelerated and
25 the doormat having good qualities can be prepared.

What is claimed is :

1. Doormat characterized in that only plural and continuous corrugated bands (b₁) having 1 to 5mm of the thickness and 2 to 20mm of width are alternately combined in different phase, or the above corrugated bands (b₁) are combined
5 between the straight bands (b₂) having 0.1 to 5mm of the thickness and 2 to 20mm of width.
2. Doormat according to claim 1, characterized in that it has the holes between corrugated band (b₁) and straight band (b₂) in order to remove easily water.
- 10 3. Doormat according to claim 1, characterized in that it has the holes between corrugated bands (b₁) having different phase with each other in order to remove easily water.
4. Doormat according to claim 1, characterized in that it is prepared by the corrugated bands (b₁) which have different widths (h₁, h₂).
- 15 5. Doormat according to claim 1, characterized in that it is prepared by the corrugated bands (b₁) which contain convexity in horizontal, convexity in longitudinal, convexity in all directions, or dotted convexity on the surface thereof.
6. Apparatus for preparing the doormat according to claims 1 to 5 comprise
20 extrusion dice (1), rollers (2, 3) having plural protuberances (4, 4') in the lower part of the extrusion dice (1), guide roller (6) placed near the rollers (2, 3) and take-up roller (7), in which the above drive roller (2) is meshed with the idle roller (3) and walls (5, 5') are optionally established between the protuberances, and the above corrugated protuberance (4) formed on the drive
25 roller(2) crosses with the corrugated protuberance (4') formed on the idle roller(3).

7. Apparatus according to claim 6, characterized in that the drive roller (2') having plural protuberances (4") is meshed with the idle roller (3') having plural protuberances(4''').

1/6

FIG. 1

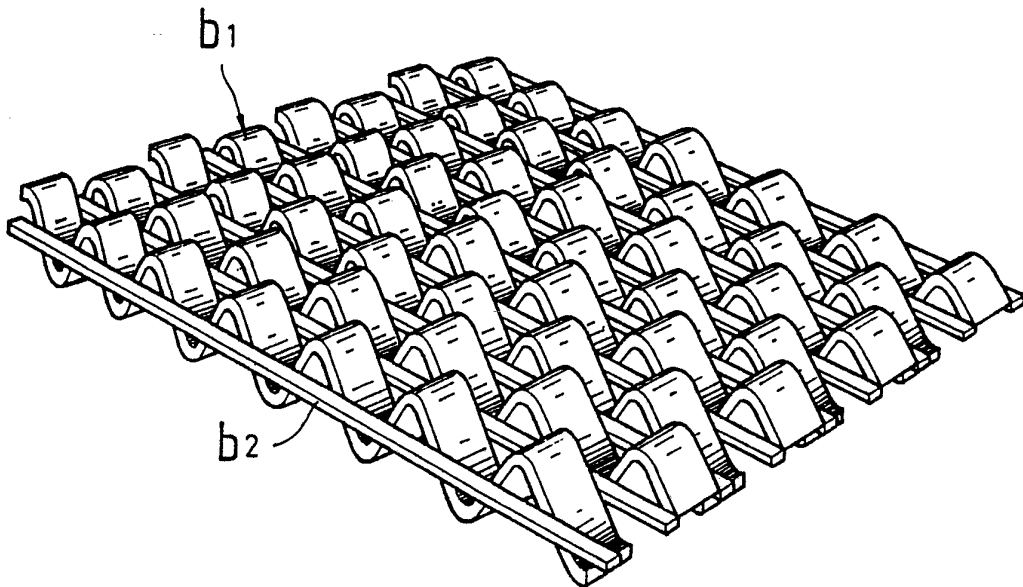
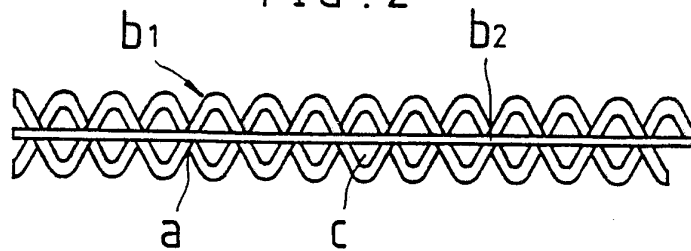

FIG. 2



2/6

FIG. 3

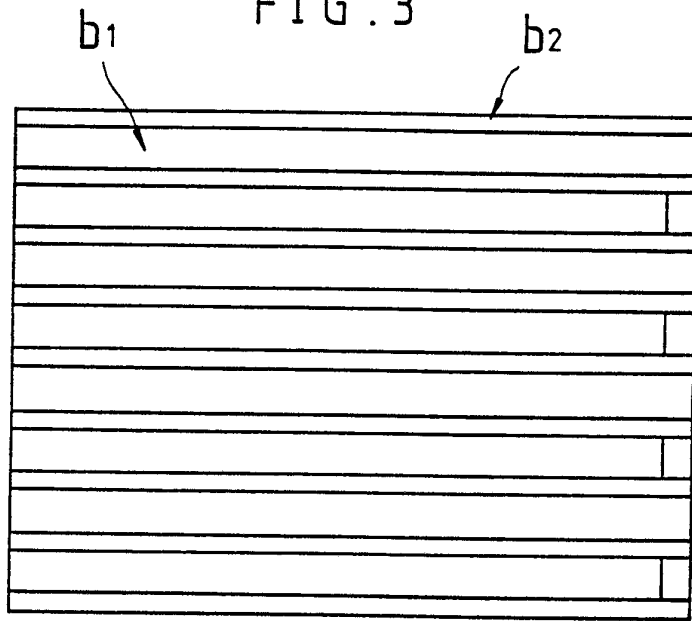
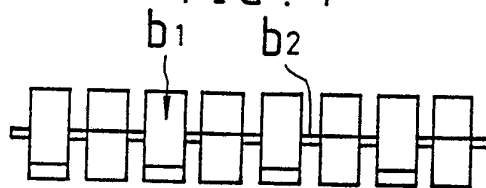

FIG. 4



3/6

FIG. 5

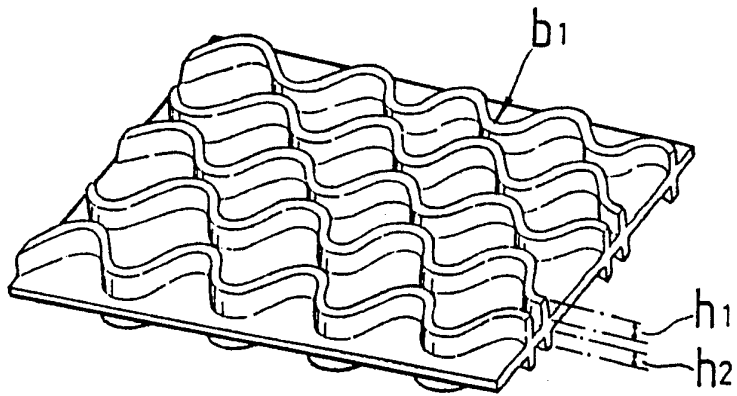
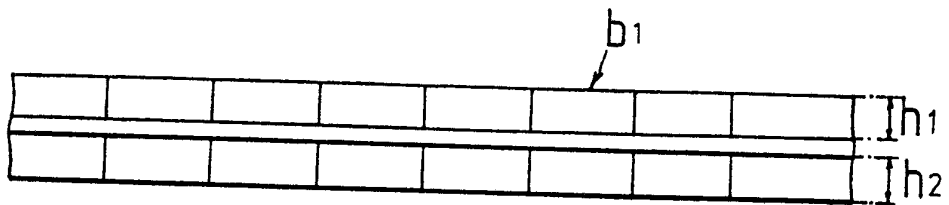

FIG. 6



4/6

FIG. 7

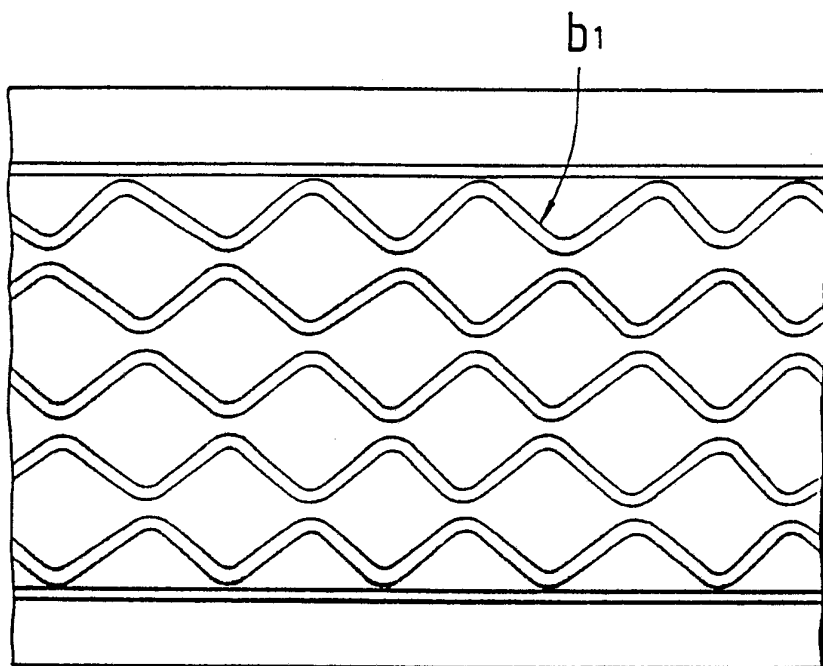
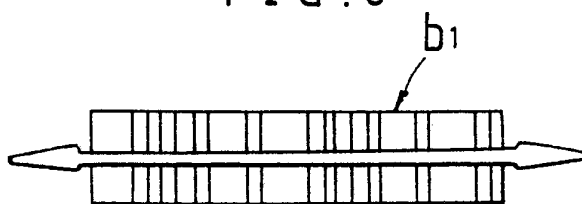
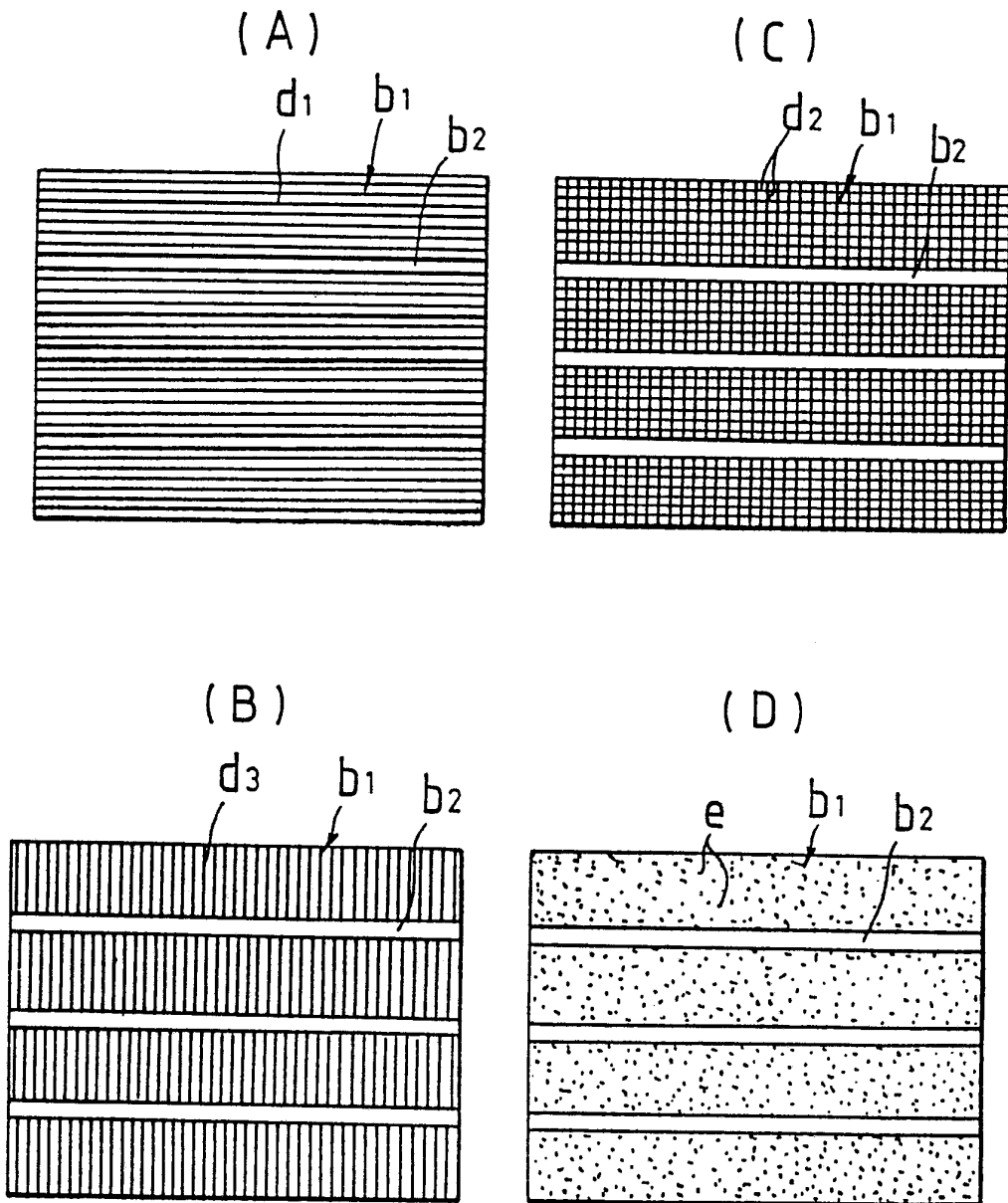

FIG. 8



5/6

FIG. 9



6/6
FIG. 10

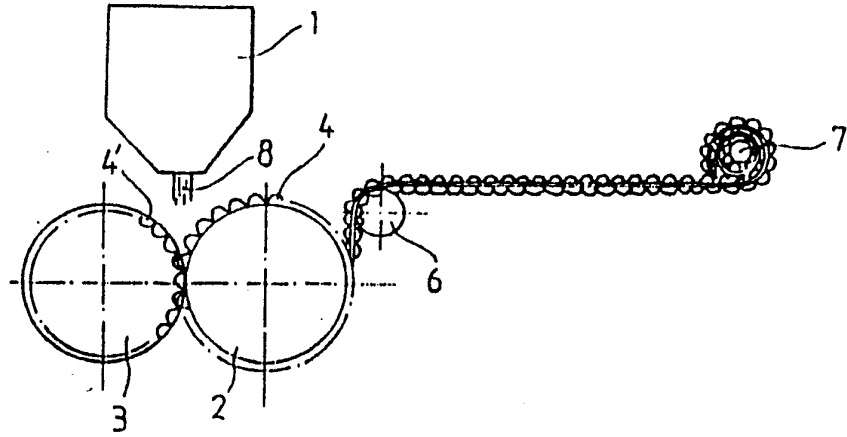

FIG. 11

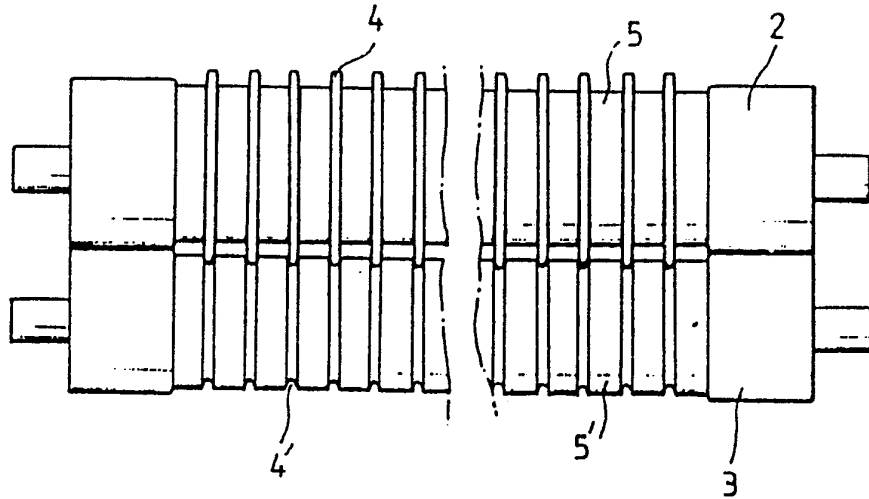
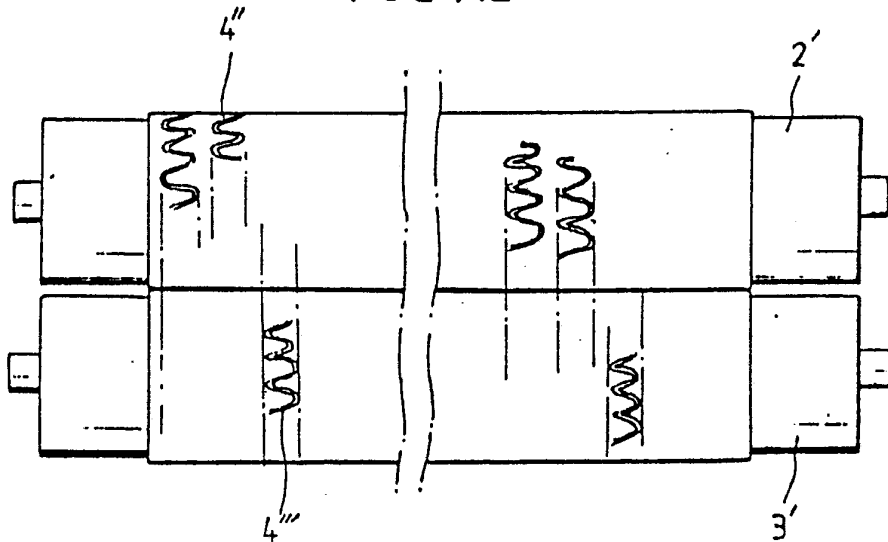

FIG. 12



INTERNATIONAL SEARCH REPORT

International Application No PCT/KR 91/00033

I. CLASSIFICATION OF SUBJECT MATTER (if several classification symbols apply, indicate all) ⁶		
According to International Patent Classification (IPC) or to both National Classification and IPC		
Int. Cl. ⁵ : A 47 L 23/22; A 47 G 27/02		
II. FIELDS SEARCHED		
Minimum Documentation Searched ⁷		
Classification System	Classification Symbols	
Int. Cl. ⁵ :	A 47 L 23/22, 23/24, 23/26; A 47 G 27/00, 27/02; B 29 C 59/04	
Documentation Searched other than Minimum Documentation to the Extent that such Documents are Included in the Fields Searched ⁸		
III. DOCUMENTS CONSIDERED TO BE RELEVANT ⁹		
Category ⁹	Citation of Document, ¹¹ with indication, where appropriate, of the relevant passages ¹²	Relevant to Claim No. ¹³
X	DE, C, 942 712 (ULVSUNDA GUMMIFABRIKS AKTIEBOLAG) 09 May 1956 (09.05.56), see fig. 1 and 3.	(1-5)
A	EP, A2, 0 199 537 (MINNESOTA MINING AND MANUFACTURING COMPANY) 29 October 1986 (29.10.86), see fig. 1 to 3.	(1-7)
A	DE, C, 14 333 (P.M. LELLAN) 18 July 1881 (18.07.81), see fig. 1 to 3.	(1)
A	US, A, 3 893 795 (NAUTA) 08 July 1975 (08.07.75), see fig. 1 to 3.	(6,7)
A	US, A, 3 235 440 (J.P. GOULD) 15 February 1966 (15.02.66), see fig. 4.	(6,7)
A	DE, A, 2 107 054 (FOSTER GRANT Co., Inc.) 23 November 1972 (23.11.72), see fig. 1.	(6,7)

<p>¹⁰ Special categories of cited documents:</p> <p>"A" document defining the general state of the art which is not considered to be of particular relevance</p> <p>"E" earlier document but published on or after the international filing date</p> <p>"L" document which may throw doubts on priority claim(s) or which is cited to establish the publication date of another citation or other special reason (as specified)</p> <p>"O" document referring to an oral disclosure, use, exhibition or other means</p> <p>"P" document published prior to the international filing date but later than the priority date claimed</p>		<p>"T" later document published after the international filing date or priority date and not in conflict with the application but cited to understand the principle or theory underlying the invention</p> <p>"X" document of particular relevance; the claimed invention cannot be considered novel or cannot be considered to involve an inventive step</p> <p>"Y" document of particular relevance; the claimed invention cannot be considered to involve an inventive step when the document is combined with one or more other such documents, such combination being obvious to a person skilled in the art.</p> <p>"&" document member of the same patent family</p>
IV. CERTIFICATION		
Date of the Actual Completion of the International Search	Date of Mailing of this International Search Report	
17 February 1992 (17.02.92)	20 February 1992 (20.02.92)	
International Searching Authority	Signature of Authorized Officer	
AUSTRIAN PATENT OFFICE	<i>Velinsky-Huber</i>	

PCT/KR 91/00033

In diesem Anhang sind die Mitglieder
der Patentfamilien der im obenge-
nannten internationalen Recherchenbericht
angeführten Patentdokumente angegeben.
Diese Angaben dienen nur zur Unter-
richtung und erfolgen ohne Gewähr.

This Annex lists the patent family
members relating to the patent documents
cited in the above-mentioned inter-
national search report. The Office is
in no way liable for these particulars
which are given merely for the purpose
of information.

La présente annexe indique les
membres de la famille de brevets
relatifs aux documents de brevets cités
dans le rapport de recherche inter-
national visée ci-dessus. Les renseigne-
ments fournis sont donnés à titre indica-
tif et n'engagent pas la responsabilité
de l'Office.

Im Recherchenbericht angeführtes Patentdokument Patent document cited in search report Document de brevet cité dans le rapport de recherche	Datum der Veröffentlichung Publication date Date de publication	Mitglied(er) der Patentfamilie Patent family member(s) Membre(s) de la famille de brevets	Datum der Veröffentlichung Publication date Date de publication
DE-C - 942712		Keine - None - Rien	
EP-A2- 199537	29-10-86	AU-A1-54494/86 AU-B2- 573428 BR-A - 8601646 CA-A1- 1263507 DE-CO- 3681624 DK-AO- 1663/86 DK-A - 1663/86 EP-A3- 199537 EP-B1- 199537 FI-AO- 861104 FI-A - 861104 FI-B - 80993 FI-C - 80993 JP-A2-61244319 NO-A - 861212 US-A - 4587148	23-10-86 09-06-88 16-12-86 05-12-89 31-10-91 11-04-86 20-10-86 28-01-87 25-09-91 17-03-86 20-10-86 31-05-90 10-09-90 30-10-86 20-10-86 06-05-86
DE-C - 14333		Keine - None - Rien	
US-A - 3893795	08-07-75	US-A - 3839514 DE-A - 2141613 DE-A1- 2166679 DE-B2- 2166679 DE-C3- 2166679 DE-B2- 2141613 DE-C3- 2141613 FR-A5- 2103409 FR-B1- 2103409 GB-A - 1327181 JP-B4-51048175 JP-A2-52017568 JP-B4-53034217 US-A - 3751550	01-10-74 16-03-72 15-05-75 13-10-77 01-06-78 20-09-79 12-06-80 14-04-72 13-02-76 15-08-73 18-12-76 09-02-77 19-09-78 07-08-73
US-A - 3235440		Keine - None - Rien	
DE-A - 2107054	23-11-72	Keine - None - Rien	