

(No Model.)

C. K. HALL & W. B. LILLARD.  
ELECTRIC WIRE COUPLING.

No. 524,980.

Patented Aug. 21, 1894.

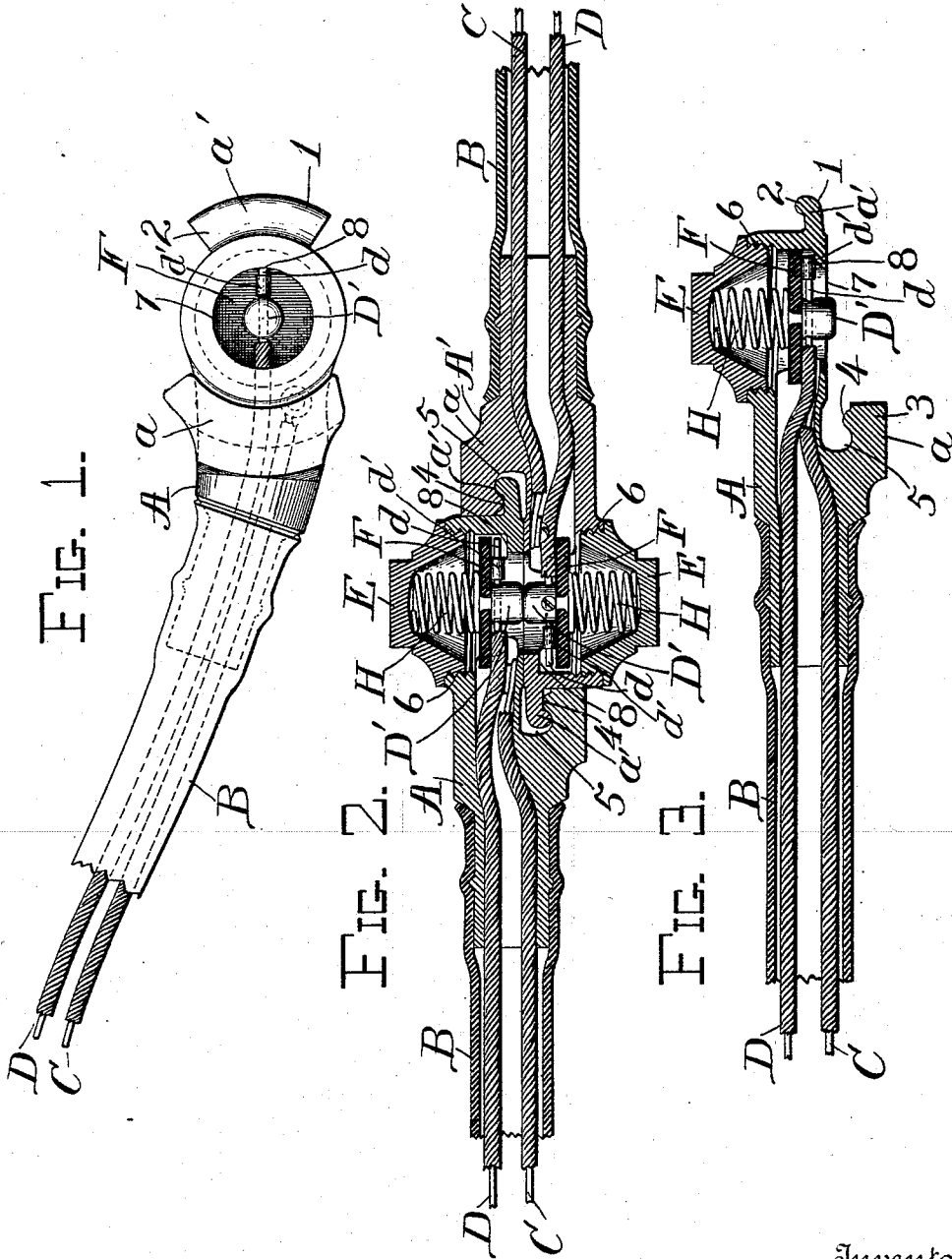

Witnesses  
*Percy C. Bowen*  
*John C. Wilson*

Inventors  
*Charles K. Hall &*  
*William B. Lillard,*  
by *Whitman & Wilkinson*  
Attorneys

# UNITED STATES PATENT OFFICE.

CHARLES K. HALL AND WILLIAM B. LILLARD, OF NEW ORLEANS,  
LOUISIANA; SAID LILLARD ASSIGNOR TO SAID HALL.

## ELECTRIC WIRE COUPLING.

SPECIFICATION forming part of Letters Patent No. 524,980, dated August 21, 1894.

Application filed December 8, 1893. Serial No. 493,124. (No model.)

*To all whom it may concern:*

Be it known that we, CHARLES K. HALL and WILLIAM B. LILLARD, citizens of the United States, residing at New Orleans, in the parish of Orleans and State of Louisiana, have invented certain new and useful Improvements in Electric Wire Couplings; and we do hereby declare the following to be a full, clear, and exact description of the invention, such as will enable others skilled in the art to which it appertains to make and use the same.

Our invention relates to improvements in electrical wire couplings, and while it is intended for use wherever it may be applicable, it is intended especially for the purpose of coupling wires from one car to another.

Reference is had to the accompanying drawings wherein the same parts are indicated by the same letters and figures throughout the several views.

Figure 1 represents an elevation of a wire coupler manufactured according to our invention, and is an inverted plan view of the coupler shown to the left in Fig. 2. Fig. 2 represents two of our improved wire couplers connected together, the two couplers being shown in central longitudinal section, and Fig. 3 represents a central longitudinal section of one of the couplers detached.

A represents the coupler head which is made of metal or other conducting material, and is connected to the flexible hose B which serves as a protection to the exposed portions of the wires C and D inclosed therein.

The wire C is electrically connected to the mass of the coupler head, and the wire D is electrically connected to the metal plunger D', which is mounted on the insulating disk F, pressed forward by the spring H held in the screw cap E.

The two coupler heads A and A' are made symmetrical in every respect, and are provided with lugs a and a' adapted to interlock as shown in Fig. 2. For this purpose the lug a' is rounded as at 1, and has an upwardly projecting tongue 2 which tongue engages in the groove 5 and hooks over the shoulder 4 in the part a of the opposite coupler. One face of the coupler is cut through and screwthreaded as at 6, and the opposite face is perforated as at 7, and provided with

a shoulder 8 adapted to support the insulated disk as it is pushed forward, and to bear on the contact piece d; as shown in Fig. 3.

The wire D is electrically connected to the plunger D' and the bared end projects therefrom along the face of the disk F so that when the plunger is released from contact with the opposite plunger, the end d of the wire will come into contact with the shoulder 8, and thus establish electrical connection between the two wires D and C.

In order that the circuit may not be permanently closed when the couplers are intentionally separated from each other, we provide a sliding sleeve d' of insulating material on the wire d, which may be interposed between the wire and the shoulder 8 as shown in Fig. 3 when it is desired to keep the ends of the wires insulated from each other.

A metal strip or plate fixed on the inner face of the disk F and connected to the plunger D' may also be used to complete the connection instead of the bared end of the wire. In this case in order that the circuit may not remain closed permanently, a switch or other equivalent device may be used to break the circuit at any convenient place in the car. If these two wires D and C be connected to any open-circuit alarm system, such for instance, as that shown in our Patents Nos. 482,306 and 504,980; then an alarm will be sounded whenever the two couplers are separated. In this way an alarm would be sounded whenever two cars break apart, or whenever any one attempts to separate the couplers with malicious intent.

It will be evident that various modifications might be made of the herein described device, which could be used without departing from the spirit of our invention.

Having thus described our invention, what we claim, and desire to secure by Letters Patent of the United States, is—

1. In an electric wire coupler, the combination with two wires insulated from each other; of a hollow metal coupler head having one of the wires electrically connected thereto; a metallic spring plunger mounted in said coupler head and insulated therefrom, the second wire being electrically connected to said plunger; and an electrical conductor extend-

ing from said plunger toward the side of said coupler head and adapted to complete the circuit when said plunger is pressed forward, substantially as and for the purposes described.

2. In an electric wire coupler, the combination with two wires insulated from each other; of a hollow metal coupler head adapted to engage in a similar coupler head, and having one of the wires electrically connected thereto; an insulating disk mounted in said coupler head and adapted to rest on a shoulder therein; a spring normally pressing said disk forward; a metallic spring plunger mounted on said insulating disk and electrically connected to the second wire, and an electrical conductor extending from said plunger toward the side of said coupler head and adapted to make contact with said shoulder of said coupler head, substantially as and for the purposes described.

3. In an electric wire coupler, the combination of the wires C and D insulated from each other, of the hollow coupler head A having engaging lugs *a* and *a'* adapted to engage in a similar coupler head, and having the shoulder 8 at the base of the recess therein, the said coupler head being electrically connected to one of said wires, an insulating disk F mounted in said coupler head and adapted to rest in the said shoulder 8, a coil spring H normally pressing said disk forward, a metallic spring plunger mounted on said insulating disk and electrically connected to the

second wire, and an electrical conductor extending from said plunger toward the side of said coupler head and adapted to make contact with said shoulder of said coupler head, substantially as and for the purposes described.

4. In an electric wire coupler, the combination of the wires C and D insulated from each other, of the hollow coupler head A having engaging lugs *a* and *a'* adapted to engage in a similar coupler head, and having the shoulder 8 at the base of the recess therein, the said coupler head being electrically connected to one of said wires, an insulating disk F mounted in said coupler head and adapted to rest in the said shoulder 8, a coil spring H normally pressing said disk forward, a metallic spring plunger mounted on said insulating disk and electrically connected to the second wire, and an electrical conductor extending from said plunger toward the side of said coupler head and adapted to make contact with said shoulder of said coupler head, and an insulating sleeve adapted to be moved along said conductor, substantially as and for the purposes described.

In testimony whereof we affix our signatures in presence of two witnesses.

CHARLES K. HALL.  
WILLIAM B. LILLARD.

Witnesses:

LOUIS LION,  
WM. H. WRIGHT.