

Oct. 20, 1970

G. E. REYNOLDS ET AL
ANGULARLY ADJUSTABLE SUPPORT MECHANISM FOR
FOURDRINIER DRAINAGE FOIL
Filed Oct. 2, 1967

3,535,201

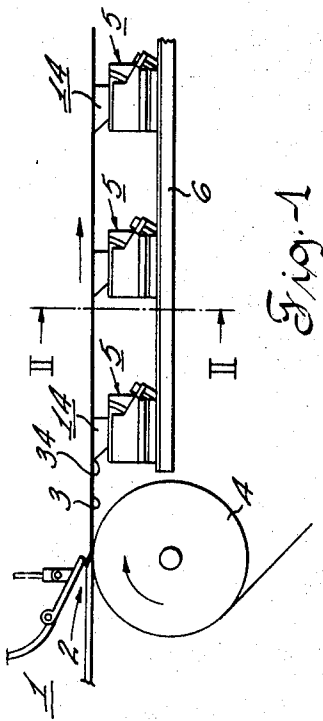

Fig. 1

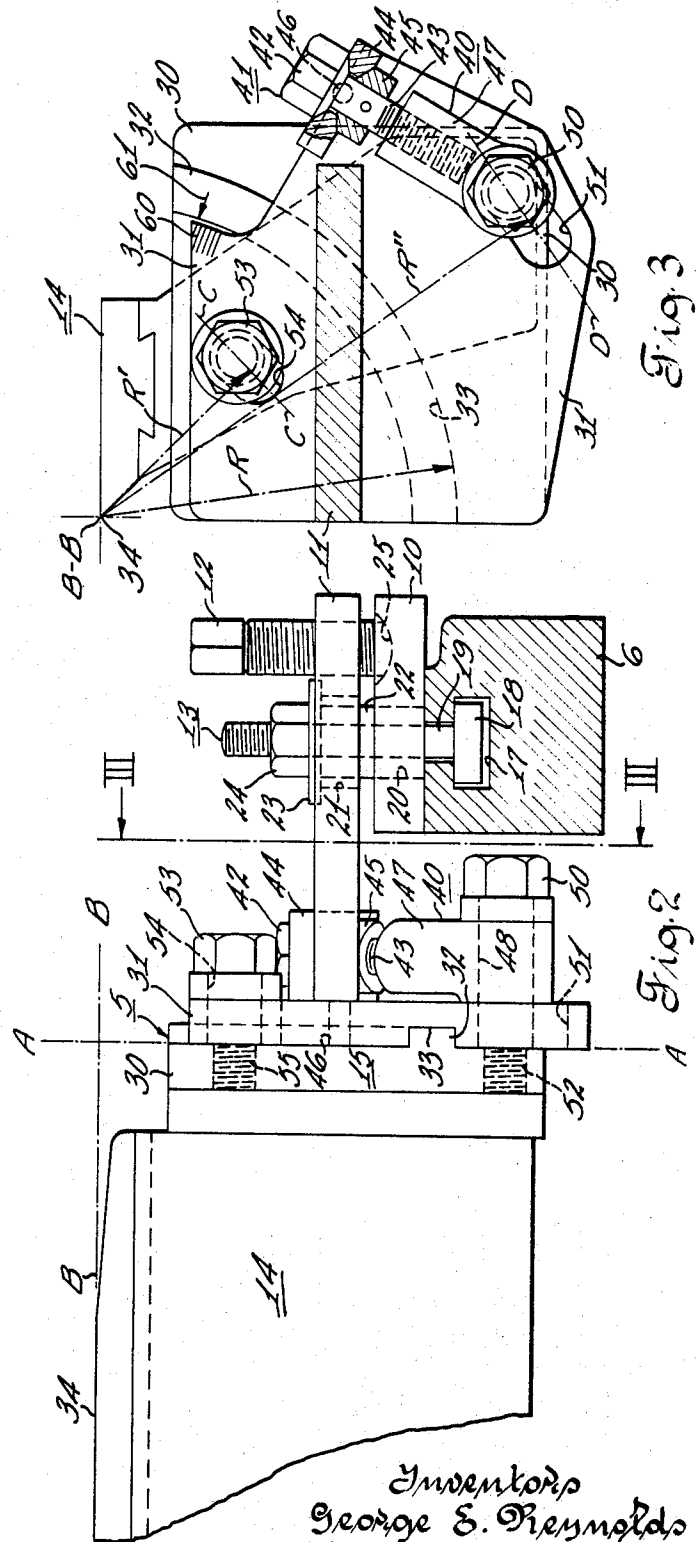

Fig. 3

Fig. 2

Inventors
George S. Reynolds
Lee R. Longman
By *Arthur M. Stueck*
Attorney

1

2

3,535,201
ANGULARLY ADJUSTABLE SUPPORT MECHANISM FOR FOURDRINIER DRAINAGE FOIL

George E. Reynolds and Lee R. Loughran, Appleton, Wis., assignors to Allis-Chalmers Manufacturing Company, Milwaukee, Wis.

Filed Oct. 2, 1967, Ser. No. 672,118

Int. Cl. D21f 1/24

U.S. Cl. 162—352

6 Claims

ABSTRACT OF THE DISCLOSURE

A portion of a papermaking machine is disclosed where paper stock discharged from a headbox is deposited upon a Fourdrinier type web forming wire provided with drainage foils beneath the wire (substituted for table rolls), and a foil is supported beneath the wire by a support mechanism including a pair of vertical plates, at each end of a foil, engaging each other with vertical surfaces cooperating to define therebetween a mated key and keyway that is arcuate in a vertical plane and that is arcuate of a radius emanating from a point in the vertical plane that lies upon a horizontal axis coincident with the leading knife-edge of the foil, to provide for adjusting the angular tilt of the foil relative to the bottom surface of the Fourdrinier wire and about a horizontal axis fixed in space and coincident with the leading knife-edge of the foil.

BACKGROUND OF THE INVENTION

Field of the invention

This invention relates to papermaking machines having drainage foils beneath a Fourdrinier type web forming wire and in particular to a foil support mechanism that is adjustable to change the angular tilt of the foil relative to the bottom surface of the Fourdrinier wire.

Description of the prior art

A concept involved in this invention is that of providing blades, now commonly called drainage foils, beneath a Fourdrinier wire in the position formerly occupied by table rolls, to achieve superior drainage of water through the bottom of the wire. The evolution of this concept to present day forms is illustrated by the following patents: British Pat. 399,739 in 1933; British Pat. 717,798 in 1954; U.S. Pat. 2,744,454 in 1956; U.S. Pats. 3,017,930 and 3,027,941 in 1962; U.S. Pat. 3,140,225 in 1964; and U.S. Pats. 3,165,440 and 3,201,308 in 1965. In all of these prior art arrangements some provision is made for adjusting the angular and spaced position of a foil beneath the bottom surface of a Fourdrinier wire that operates with varying degrees of speed, convenience, observability and certainty.

SUMMARY OF THE INVENTION

It is a primary object of the present invention to provide a new and improved arrangement for adjustably controlling the rate of water removal through the bottom of a Fourdrinier web forming wire while the machine is in operation and the wire is moving.

Another object of the present invention is to provide a new and improved arrangement for adjusting the angular tilt of a drainage foil relative to the bottom surface of a Fourdrinier wire and about a horizontal axis fixed in space and coincident with the leading knife-edge of the foil in order that the angular tilt may be changed without changing the position of the foils leading knife-edge relative to the bottom of the Fourdrinier wire, and in particular that the angular tilt may be changed without danger that this adjustment will move the leading knife-edge of

the foil into contact with the wire such that the foil will be subjected to excessive wear or that the leading knife-edge will cut the Fourdrinier wire.

Another object of the present invention is to provide a new and improved arrangement for raising and lowering a drainage foil relative to the bottom surface of a Fourdrinier wire, and to do so without upsetting the angular adjustment of the foil relative to the horizontal plane of the Fourdrinier wire.

Still another object of the present invention is to provide a new and improved arrangement for accomplishing the aforesaid objects rapidly with certainty and conveniently with a mechanism having settings that can easily be observed by operating personnel.

According to a preferred embodiment of the present invention, and end of a drainage foil may be supported by a mechanism carried by a rail alongside of and beneath the web forming strand of a Fourdrinier wire. The mechanism may include a lower support member mounted on the side rail and an upper support member for carrying a foil, with the support being carried by spacer posts which are adjustable to raise and lower the upper support and attached foil relative to the lower support and rail. The end of the drainage foil is connected to the upper support through a foil angle adjusting mechanism. This mechanism includes a pair of vertical plates. A first plate of the pair of plates adjacent the foil is secured to the foil and a second plate of the pair is adjacent the upper support member and remote of the foil. This second plate is secured to the adjacent upper support member. The two plates have engaging vertical surfaces that cooperate to define therebetween a mating key and keyway. The mated key and keyway has a configuration that is arcuate in a vertical plane therebetween, and the radius of the arc emanates from a point in the vertical plane above the arc and on a horizontal axis coincident with the leading knife-edge of the foil. The mechanism also includes a variable length link assembly. One end of the link assembly is pivotally connected to the second plate, i.e., the plate remote from the foil. The other end of the link assembly is connected to a pivot that passes through a slot in the second plate and is attached to the first plate, i.e., the plate adjacent the foil. Adjusting the length of the link assembly moves the first plate in a vertical plane and rotates the foil about the axis coincident with the leading edge of the foil so this adjustment changes the angular tilt of the foil relative to the bottom of the Fourdrinier wire but the leading knife-edge of the foil remains fixed in space. When it is desired to raise or lower the entire foil, including its leading edge, the spacer posts are adjusted to raise or lower the upper support and attached foil relative to the lower support and rail.

Other features and objects of the invention that have been attained will appear from the more detailed description of an embodiment of the invention shown in the accompanying drawings.

BRIEF DESCRIPTION OF THE DRAWING

FIG. 1 is a diagrammatic side elevation view of a portion of a papermaking machine showing a portion of a headbox, a breast roll, Fourdrinier wire and drainage foil assemblies according to the present invention;

FIG. 2 is an enlarged and fragmentary view of one of the drainage foil assemblies of FIG. 1, showing the assembly in greater detail and partly in section taken along line II—II of FIG. 1; and

FIG. 3 is a view partly in section taken along line III—III in FIG. 2.

DESCRIPTION OF THE PREFERRED EMBODIMENT

Referring to the drawing and FIG. 1 in particular, a portion of a papermaking machine is shown wherein a

headbox 1 discharges pulp through a slice opening 2 to deposit the pulp on a Fourdrinier wire 3 as it leaves a breast roll 4 that is turning in the direction indicated by the arrow. A plurality of drainage foil assemblies 5 are shown arranged beneath the wire 3 and mounted on side rails 6.

Referring to FIG. 2, the foil support assembly 5 is shown as having a lower support member 10, an upper support member 11 that may be raised and lowered by a threaded post 12 carried on top of support member 10 and secured to rail 6 by a bolt 13, a foil 14, and a foil angle adjusting mechanism 15 connecting foil 14 to upper support member 11.

The lower support member 10 is arranged on top of rail 6 over a slot 17 having an inverted T-shaped configuration when viewed in cross section as in FIG. 2. The bolt 13 has a head 18 arranged in slot 17 and a shank 19 arranged to project upwardly through a hole 20 in lower support 10 and through a hole 21 in upper support 11. A sleeve 22 surrounds shank 19 within and between the holes 20, 21. A washer 23 and nut 24 are shown on the end of bolt 13 projecting upwardly of upper support 11. The top surface of the lower support 10 is provided with a concave seat 25 for the lower end of the threaded post 12.

The foil angle adjusting mechanism 15 includes a pair of vertical plates 30, 31. Plate 30 is adjacent foil 14 and is attached thereto. Plate 31 is adjacent upper support member 11 and is attached to that member. The two plates 30, 31 have vertical surfaces that engage in a vertical plane A—A and cooperate to define therebetween a mated key 32 and keyway 33. As shown in FIG. 2, in the preferred embodiment the key 32 projects from plate 30 into a keyway 33 in plate 31. The key 32 may however project from plate 31 into a keyway 33 in plate 30. As shown in FIG. 3 the configuration of the key and keyway 32, 33 is arcuate with a radius R emanating from a point on axis B—B that lies on plane A—A shown in FIGS. 2 and 3 as being coincident with the leading knife-edge 34 of foil 14. The term "leading" as herein used to describe knife-edge 34 refers to the orientation shown in FIG. 1 where it is shown that the knife-edge 34 is the lead edge with respect to the approach of wire 3 toward foil 14.

The foil angle adjusting mechanism 15 also includes a variable length link assembly 40. The assembly 40 includes a threaded bolt 41 having a head 42 and a shank 43 projecting through a collar 44. A clamp piece 45 is provided around the bolt shank 43 and cooperates with the head 42 to hold the bolt 41 for rotation relative to the collar 44. The collar 44 is pivotally connected to the vertical plate 31 by any suitable means, such as for example a shaft 46 mounted to rotate relative to plate 31. The end of bolt shank 43 remote of the bolt head 42, threadingly engages a link 47. The link 47 has a bore 48 (see FIG. 2) perpendicular to shank 43. A bolt 50 projects through the bore 48 of link 47 and through a slot 51 in plate 31 to plate 30 where an end portion 52 of bolt 50 is threadingly attached to plate 30. Another bolt 53 projects through another slot 54 in plate 31 to plate 30 where a threaded end portion 55 of bolt 53 is attached to plate 30. Both of the slots 51 and 54 in plate 31 are oriented (see FIG. 3) to present their major axes C—C and D—D generally perpendicular to a radius R' and R'' from a point on axis B—B.

As shown in FIG. 3, a plurality of scribe marks 60 may be cut or otherwise applied to plate 31 opposite an arrow 61 cut or otherwise applied to key 32. The arrow and scribe marks may be arranged relative to each other as a calibration or setting indicator presenting a visual indication of the angular position of foil 14 relative to Fourdrinier wire 3.

The assembly according to the present invention is shown in the drawings and has been described with reference to but one end of foil 14. Both ends of the foil 14 may, of course, be similarly supported.

In the operation of the described apparatus the position of the foil assembly 5 along rail 6 may be adjusted by loosening bolts 13 and then sliding lower support member 10 along rail 6 until assembly 5 is at a desired location. If it is desired to adjust the vertical position of foil 14 relative to wire 3, the nut 24 on shank 19 of bolt 13 is turned to move upwardly on shank 19. Post 12 may then be turned to project downwardly a greater distance below upper support 11 which has the effect of raising support 11 and attached structures, relative to lower support 10 and wire 3. Turning post 12 to project downwardly a lesser distance below support 11 of course will lower support 11 and all structures carried thereby. When post 12 has been turned to carry foil 14 at the desired level relative to wire 3 and/or assembly 5 is moved to a desired location on rail 6, then nut 24 is tightened on shank 19 of bolt 13 to secure the apparatus in position.

The angular tilt of foil 14 relative to wire 3 may be adjusted independently of any adjustments such as have been described and may or may not have been performed. To adjust the angular tilt of foil 14 bolts 50 and 53 are first loosened. Then the head 42 of bolt 41 is turned to move shank 43 and link 47 together or apart to change the effective length of the link assembly 40. If, from the position shown in FIG. 3, bolt 41 is turned to move shank 43 and link 47 apart to increase the effective length of assembly 40, the link 47 will move the bolt 50 downwardly in slot 51, pivoting the entire link assembly 40, and including collar 44, about shaft 46. As shown in FIG. 3, this pivotal movement about shaft 46 will be clockwise when assembly 40 is lengthened and counterclockwise when shortened. As the link assembly 40 is lengthened and link 47 moves down slot 51, the end portion 52 of bolt 50 will move plate 30 and attached foil 14 relative to plate 31 and attached support 11. Key 32 and keyway 33 will guide this movement to be pivotal clockwise (as seen in FIG. 3) and about the axis B—B coincident with the leading knife-edge 34 of foil 14. Shortening link assembly 40 will pivot plate 30 and attached foil 14 counterclockwise (as seen in FIG. 3). The pivotal movement in either clock direction will however be about the axis B—B coincident with leading knife-edge 34 of foil 14 and the position of edge 34 relative to Fourdrinier wire 3 will not change. Thus the described pivotal adjustment of foil 14 cannot inadvertently bring knife-edge 34 in a position that may expose the foil 14 to excessive wear or cause the edge 34 to cut the Fourdrinier wire 3.

From the foregoing detailed description of the present invention it has been shown how the objects of the invention have been attained in a preferred manner. However, modifications and equivalents of the disclosed concepts such as readily occur to those skilled in the art are intended to be included within the scope of this invention. Thus, the scope of this invention is intended to be limited only by the scope of the claims such as are or may hereafter be appended hereto.

The embodiments of the invention in which an exclusive property or privilege is claimed are defined as follows:

1. In a Fourdrinier wire drainage foil assembly having a foil with a horizontal leading knife-edge, a support member and a foil angle adjusting mechanism, said foil angle adjusting mechanism comprising a pair of vertical plates, a first of said plates being adjacent said foil and attached thereto, a second of said plates being adjacent said support member and attached thereto, said plates having engaging vertical surfaces that cooperate to define therebetween a mated key and keyway, said key and keyway having an arcuate configuration in a vertical plane and of a radius emanating from a point on a horizontal axis coincident with said leading edge, to provide for pivotal motion of said first plate and attached foil relative to said second plate and attached support member about said horizontal axis coincident with said leading knife-edge.

5

2. In the assembly according to claim 1, said foil angle adjusting mechanism including a variable length link assembly operatively connected on one end thereof to said first plate and on the other end to said second plate to pivot said first plate and attached foil relative to said second plate and attached support upon lengthening and shortening said link assembly.

3. In an assembly according to claim 2, said variable length link assembly comprising a first and a second part on a side of said second plate opposite said first plate and adjustably engaged to provide a link of adjustable length, said first part being connected to said second plate and said second part being connected to said first plate through a slot opening in said second plate.

4. In an assembly according to claim 3, said first part of said link assembly being connected to said second plate by a means pivotal about an axis perpendicular to said second plate to provide for movement of said link assembly in a vertical plane as the length thereof is adjusted and the second part thereof moves in said vertical plane relative to said slot in said second plate to move said first plate and attached foil relative thereto.

5. In an assembly according to claim 4, said slot being disposed substantially perpendicular to a radius emanat-

6

ing from said point on said horizontal axis coincident with said leading knife-edge.

6. In an assembly according to claim 5, a second slot in said second plate, said second slot being disposed between said foil and the first said slot, said second slot being also disposed substantially perpendicular to a radius emanating from said point on said horizontal axis coincident with the leading knife-edge, and a bolt arranged to project through said second slot from said link assembly side of said second plate to engage said first plate and secure said first plate to said second plate in selected relative positions therebetween.

References Cited

UNITED STATES PATENTS

3,323,981	6/1967	Heys	-----	162—352
3,323,982	6/1967	Hill	-----	162—354 X

REUBEN FRIEDMAN, Primary Examiner

T. A. GRANGER, Assistant Examiner

U.S. Cl. X.R.

162—374