



- (51) **International Patent Classification:**
B29C 45/43 (2006.01) B29B 11/08 (2006.01)
- (21) **International Application Number:**
PCT/CA2011/050584
- (22) **International Filing Date:**
22 September 2011 (22.09.2011)
- (25) **Filing Language:** English
- (26) **Publication Language:** English
- (30) **Priority Data:**
61/406,641 26 October 2010 (26.10.2010) US
- (71) **Applicant (for all designated States except US):** HUSKY INJECTION MOLDING SYSTEMS LTD. [CA/CA]; 500 Queen Street South, Bolton, Ontario L7E 5S5 (CA).
- (72) **Inventors; and**
- (75) **Inventors/Applicants (for US only):** MCCREADY, Derek Robertson [GB/CA]; 1032 Serdica Court, Mississauga, Ontario L5H 4H8 (CA). PAPA, Renato [CA/CA]; 75 Grackle Trail, Scarborough, Ontario M1X 2C5 (CA).
- (74) **Agent:** HUSKY INTELLECTUAL PROPERTY SERVICES; c/o Husky Injection Molding Systems Ltd., 500 Queen Street South, Bolton, Ontario L7E 5S5 (CA).
- (81) **Designated States (unless otherwise indicated, for every kind of national protection available):** AE, AG, AL, AM,

AO, AT, AU, AZ, BA, BB, BG, BH, BR, BW, BY, BZ, CA, CH, CL, CN, CO, CR, CU, CZ, DE, DK, DM, DO, DZ, EC, EE, EG, ES, FI, GB, GD, GE, GH, GM, GT, HN, HR, HU, ID, IL, IN, IS, JP, KE, KG, KM, KN, KP, KR, KZ, LA, LC, LK, LR, LS, LT, LU, LY, MA, MD, ME, MG, MK, MN, MW, MX, MY, MZ, NA, NG, NI, NO, NZ, OM, PE, PG, PH, PL, PT, QA, RO, RS, RU, RW, SC, SD, SE, SG, SK, SL, SM, ST, SV, SY, TH, TJ, TM, TN, TR, TT, TZ, UA, UG, US, UZ, VC, VN, ZA, ZM, ZW.

(84) **Designated States (unless otherwise indicated, for every kind of regional protection available):** ARIPO (BW, GH, GM, KE, LR, LS, MW, MZ, NA, SD, SL, SZ, TZ, UG, ZM, ZW), Eurasian (AM, AZ, BY, KG, KZ, MD, RU, TJ, TM), European (AL, AT, BE, BG, CH, CY, CZ, DE, DK, EE, ES, FI, FR, GB, GR, HR, HU, IE, IS, IT, LT, LU, LV, MC, MK, MT, NL, NO, PL, PT, RO, RS, SE, SI, SK, SM, TR), OAPI (BF, BJ, CF, CG, CI, CM, GA, GN, GQ, GW, ML, MR, NE, SN, TD, TG).

Declarations under Rule 4.17:

— as to applicant's entitlement to apply for and be granted a patent (Rule 4.17(ii))

Published:

— with international search report (Art. 21(3))

(54) Title: A MOLD STACK FOR A PREFORM

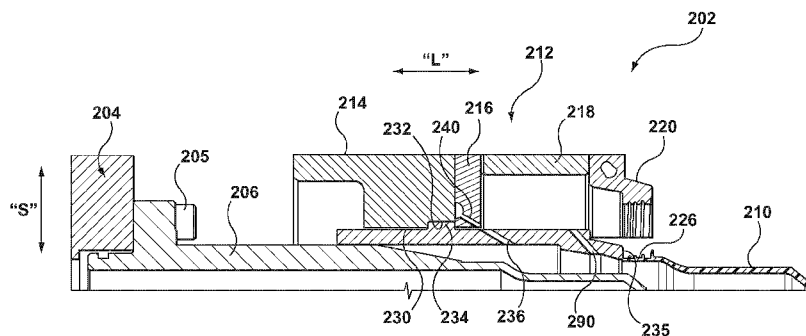

FIG. 2

(57) **Abstract:** There is provided a stripper assembly (12) for use in a mold stack (202) for forming a preform (210) suitable for blow-molding into a final-shaped container. The stripper assembly (12) comprises a stripper plate (214) connectable, in use, to a stripper plate actuator; neck rings (220) configured to cooperate to define a portion a neck region (226) of the preform (210); a stripper ring (230) configured to define at least a portion of a top sealing surface of the neck region (226) of the preform (210); the stripper plate (214) being configured to actuate the neck rings (220) and the stripper ring (230), in unison, along substantially the whole length of a complete ejection path, which is substantially parallel to a longitudinal axis of the mold stack (202); and wherein the neck rings (220) are configured for movement in a direction substantially perpendicular to the longitudinal axis of the mold stack, over at a portion of the complete ejection path, the stripper ring (230) having an air channel (236) configured to directed a flow of fluid towards the preform.



A MOLD STACK FOR A PREFORM

FIELD OF THE INVENTION

5 The present invention generally relates to, but is not limited to, a molding system, and more specifically the present invention relates to, but is not limited to, a mold stack for a preform.

BACKGROUND OF THE INVENTION

10 Molding is a process by virtue of which a molded article can be formed from molding material by using a molding system. Various molded articles can be formed by using the molding process, such as an injection molding process. One example of a molded article that can be formed, for example, from polyethylene terephthalate (PET) material is a preform that is capable of being subsequently blown into a beverage container, such as, a bottle and the like.

15 As an illustration, injection molding of PET material involves heating the PET material (or other suitable molding material for that matter) to a homogeneous molten state and injecting, under pressure, the so-melted PET material into a molding cavity defined, at least in part, by a female cavity piece and a male core piece mounted respectively on a cavity plate and a core plate of a mold. The cavity plate and the core plate are urged together and are held together by clamp force, the clamp force being sufficient to keep the cavity and the core pieces together against the pressure of the injected PET material. The molding cavity has a shape that substantially corresponds to a final cold-state shape of the molded article to be molded. The so-injected PET material is then cooled to a temperature sufficient to enable ejection of the so-formed molded article from the molding cavity. When cooled, the molded article shrinks inside of the molding cavity and, as such, when the cavity and core plates are urged apart, the molded article tends to remain associated with the core piece. Accordingly, by urging the core plate away from the cavity plate, the molded article can be subsequently demolded by ejecting it off the core piece. Ejection structures are known to assist in removing the molded articles from the core halves. Examples of the ejection structures include stripper plates, stripper rings and neck ring, ejector pins, etc.

20

25

30

When dealing with molding a preform that is capable of being subsequently blown into a beverage container, one consideration that needs to be addressed is forming a so-called "neck region".

Typically and as an example, the neck region includes (i) threads (or other suitable structure) for accepting and retaining a closure assembly (ex. a bottle cap), and (ii) an anti-pilferage assembly to cooperate, for example, with the closure assembly to indicate whether the end product (i.e. the beverage container that has been filled with a beverage and shipped to a store) has been tampered with in any way. The neck region may comprise other additional elements used for various purposes, for example, to cooperate with parts of the molding system (ex. a support ledge, etc.). As is appreciated in the art, the neck region can not be easily formed by using the cavity and core halves. Traditionally, split mold inserts (sometimes referred to by those skilled in the art as “neck ring”) have been used to form the neck region.

With reference to Figure 1, a section along a portion of an injection mold 50 illustrates a typical molding insert stack assembly 52 that can be arranged (in use) within a molding machine (not depicted). The description of Figure 1 that will be presented herein below will be greatly simplified, as it is expected that one skilled in the art will appreciate configuration of other components of the injection mold 50 that will not be discussed in the following description.

The molding insert stack assembly 52 includes a split mold insert pair 54 that together with a mold cavity insert 56, a gate insert 58 and a core insert 60 defines a molding cavity 62. Molding material can be injected into the molding cavity 62 from a source of molding material (not depicted) via a receptacle (not separately numbered) in the gate insert 58 to form a molded article. In order to facilitate forming of the neck region of the molded article and subsequent removal of the molded article therefrom, the split mold insert pair 54 comprises a pair of complementary split mold inserts (not separately numbered) that are mounted on adjacent slides of a slide pair (not depicted). The slide pair is slidably mounted on a top surface of a stripper plate (not depicted). As commonly known, and as, for example, generally described in United States patent 6,799,962 to Mai et al (granted on October 5, 2004), the stripper plate (not depicted) is configured to be movable relative to the cavity insert 56 and the core insert 60, when the mold is arranged in an open configuration, whereby the slide pair, and the complementary split mold inserts mounted thereon, can be laterally driven, via a cam arrangement (not shown) or any other suitable known means, for the release of the molded article from the molding cavity 62.

Several types of the split mold insert pair 54 are known in the art. For example, the split mold insert pair 54 can be of a cavity-lock type or a core-lock type (depicted in Figure 1), depending on

an arrangement that is used for locking the split mold insert pair 54, in use, relative to the mold cavity insert 56 and the core insert 60. The split mold insert pair 54 can also define a portion of the neck region (as is the case in Figure 1) or the whole of the neck region or, put another way, “encapsulate” the neck region. One of the functions performed by the split mold insert pair 54 is to assist in ejecting the molded article off the core insert 60 by “sliding” the molded article off the core insert 60.

An example of the latter is disclosed in a co-owned US patent No. 6,989, 124 issued on January 24, 2006 to Miller et al., which teaches an injection molding method and apparatus for ejecting a molded plastic article from a mold. A lifting structure and/or step is provided with a lifting portion which is configured to contact substantially one half of an end of the molded plastic article along a line substantially perpendicular to the lifting direction. Since the molded plastic article is lifted by its end, the article does not have to be solidified at its interior, thus allowing earlier removal of the article from the mold, reducing cycle time. A tapered surface forms an acute angle with respect to the lifting portion to form a tight seal with the mold, preventing leakage. Preferably, the neck ring engages only an outer circumferential portion of the molded plastic article during a majority of a mold opening stroke.

Co-owned US patent No. 7,128,865 issued to Martin on October 31st, 2006 discloses an injection molding method and apparatus for ejecting a molded plastic preform from a mold. A first lifting structure and/or step is configured to have an inner surface with an area for sealing and aligning with a complementary surface on a core, and to have an upper surface with an area for sealing and aligning with a complementary surface on a second lifting structure, said upper surface of said first lifting structure being configured to lift a molded plastic preform from the injection mold in a lifting direction for a first period of time, the lower portion of the molded plastic preform lying in a plane substantially perpendicular to the lifting direction. A second lifting structure and/or step is configured to have an inner surface configured to lift an outer surface of the molded plastic preform from the injection mold in the lifting direction for a second period of time, the outer surface of the molded plastic preform including structure lying in a plane substantially parallel with the lifting direction. Since the molded plastic preform is lifted by its end, the preform does not have to be solidified at its interior, thus allowing earlier removal of the preform from the mold, reducing cycle time.

SUMMARY OF THE INVENTION

According to a first broad aspect of the present invention, there is provided a stripper assembly for use in a mold stack for forming a preform suitable for blow-molding into a final-shaped container.

5 The stripper assembly comprises a stripper plate connectable, in use, to a stripper plate actuator; neck rings configured to cooperate to define a portion a neck region of the preform; a stripper ring configured to define at least a portion of a top sealing surface of the neck region of the preform; the stripper plate being configured to actuate the neck rings and the stripper ring, in unison, along substantially the whole length of a complete ejection path, which is substantially parallel to a longitudinal axis of the mold stack; and wherein the neck rings are configured for movement in a direction substantially perpendicular to the longitudinal axis of the mold stack, over at a portion of the complete ejection path, the stripper ring having an air channel configured to directed a flow of fluid towards the preform.

15 According to a second broad aspect of the present invention, there is provided a stripper ring configured to be installed, in use, as a part of a stripper assembly for use in a mold stack for forming a preform suitable for blow-molding into a final-shaped container. the stripper assembly includes a stripper plate connectable, in use, to a stripper plate actuator; neck rings configured to cooperate to define a portion a neck region of the preform; a stripper ring configured to define at least a portion of a top sealing surface of the neck region of the preform; the stripper plate being configured to actuate the neck rings and the stripper ring, in unison, along substantially the whole length of a complete ejection path, which is substantially parallel to a longitudinal axis of the mold stack; and wherein the neck rings are configured for movement in a direction substantially perpendicular to the longitudinal axis of the mold stack, over at a portion of the complete ejection path, the stripper ring having an air channel configured to directed a flow of fluid towards the preform. The stripper ring comprises an air channel configured to directed a flow of fluid towards the preform.

30 These and other aspects and features of non-limiting embodiments of the present invention will now become apparent to those skilled in the art upon review of the following description of specific non-limiting embodiments of the invention in conjunction with the accompanying drawings.

DESCRIPTION OF THE DRAWINGS

A better understanding of the non-limiting embodiments of the present invention (including alternatives and/or variations thereof) may be obtained with reference to the detailed description of the non-limiting embodiments along with the following drawings, in which:

5 Figure 1 is a cross-section view of a portion of an injection mold that incorporates a typical molding insert stack assembly, implemented in accordance with known techniques.

Figure 2 depicts a cross-section view of a portion of an injection mold that incorporates a mold stack implemented in accordance with non-limiting embodiments of the present invention.

10 Figure 3 depicts a cross-section view of a portion of an injection mold that incorporates the mold stack that is being implemented in accordance with another non-limiting embodiment of the present invention.

DETAILED DESCRIPTION OF EMBODIMENTS

15 With reference to Figure 2, a non-limiting embodiment of a portion of a mold stack 202 will now be described in greater detail, in which Figure 2 depicts a cross section taken along a longitudinal axis thereof.

20 The portion of the mold stack 202, as depicted in Figure 2, is receivable in use within a core plate 204, which is implemented according to conventional designs and, as such, will not be described in great detail herein. Suffice it to state that the mold stack 202 includes a core insert 206 operatively coupled to the core plate 204. Construction of the core insert 206 can be implemented in accordance with known techniques and, as such, will not be described in great detail herein. The core insert 206 is coupled to the core plate 204 by means of a bolt 205, however in alternative embodiments of the present invention other coupling means can be used to couple the core insert 206 to the core plate 204.

25 The function of the core insert 206 is also well-known in the art and includes *inter alia* the function of defining an inner portion of a preform 210, the preform 210 being of a kind suitable for subsequent blow-molding into a final-shaped container, such as a beverage container or the like.

Even though not depicted, the mold stack 202 further includes a cavity insert, which cooperates with the core insert 206 to define portions of a molding cavity that forms the preform 210. The cavity insert can be implemented in a substantially similar manner to the mold cavity insert 56 of Figure 1.

5 The mold stack 202 further includes a stripper assembly 212. Within the embodiment illustrated, the stripper assembly 212 includes a stripper plate 214, a wear plate 216, a neck ring slide 218 and neck ring 220. Even though not depicted in Figure 2, those of skill in the art will appreciate that the mold stack 202, includes a pair of the neck rings 220, each neck ring 220 being coupled to a
10 respective one of the neck ring slides 218. The stripper plate 214 is operatively coupled to a stripper plate actuator, which is not depicted, but is well-known to those of skill in the art (for example, a hydraulic actuator, a servo-motor actuator and the like). The stripper plate actuator (not depicted) is configured to move the stripper plate, back and forth, in a direction depicted in Figure 2 at "L" or, in other words, a direction, which is substantially parallel to the longitudinal axis of the mold stack 202.

15 Within the illustration, the neck ring 220 is of a cavity-lock type. The neck ring 220 performs at least two functions – defining a portion of a neck region 226 of the preform 210 and assisting in ejection of the preform 210 off the core insert 206. For the performance of the ejection function, the neck ring 220 is operatively coupled to the neck ring slide 218 by suitable means, such as bolts (not depicted), for movement therewith as will be described momentarily. The neck ring slide 218
20 is coupled to a neck ring slide actuator (not depicted), which can be implemented as cam(s), servo motor(s) and the like. The neck ring slide actuator (not depicted) is configured to move the neck ring slide 218, back and forth, in a direction depicted in Figure 2 at "S" or, in other words, a direction which is substantially perpendicular to a longitudinal axis of the mold stack 202. The wear plate 216 is provided between the stripper plate 214 and the neck ring slide 218 to prevent
25 substantial damage to the stripper plate 214 and/or neck ring slide 218 during the movement of the neck ring slide 218 relative to the stripper plate 214 in the direction "S". The wear plate 216 is implemented according to known techniques and is coupled to the stripper plate 214 by suitable couplers, such as bolts (not depicted) and the like.

30 So far, implementation of the stripper assembly 212 is substantially similar to that of the prior art approaches. Accordingly, those skilled in the art will easily appreciate how the stripper assembly

212 functions. However, for the benefit of the reader, a brief description will be presented. It is worthwhile noting that Figure 2 depicts the mold stack 202 in a “mold opening configuration”, whereby the preform 210 has been molded, sufficiently cooled to enable safe ejection and ejection thereof has commenced.

5 Generally speaking, when a mold (not depicted) housing the mold stack 202 is unclamped and starts to open, the stripper plate actuator (not depicted) actuates the stripper plate 214 in a right-bound direction, as viewed in Figure 2. The wear plate 216, the neck ring slide 218 and the neck ring 220 initially start to move, in unison, with the stripper plate 214, effectively moving the preform 210 in the right-bound direction, so that it can be eventually removed from the core insert
10 206. This is when the mold stack 202 reaches the configuration depicted in Figure 2.

After a certain portion of this movement (which is determined, amongst other things, by the length of the preform 210, etc.), the neck ring slides actuator (not depicted) starts to actuate the neck ring slide 218 (and, therefore, the neck ring 220) outwardly into the direction “S”. At this point, the wear plate 216, the neck ring slide 218 and the neck ring 220 continue to move in the direction
15 “L”, while the neck ring slide 218 and the neck ring 220 also move in the direction “S”. Eventually, the two halves of the neck ring 220 are separated enough to let the neck region 226, which includes several undercuts such as a thread, an anti-tampering ledge, etc. (all of these undercuts not separately numbered), of the preform 210 to be removed from the mold stack 202.

Eventually, the preform 210 is removed from the core insert 206 and is transferred to a suitable
20 downstream processing device (not depicted), such as a take-off robot (not depicted) and the like. It is worthwhile noting that a path of travel travelled by the stripper assembly 212, in the direction “L” (i.e. the longitudinal direction) between the position showed in Figure 2 and a position where the preform 210 is removed from the core insert 206, can be thought of as a “complete ejection path” of the stripper assembly 212.

25 According to a non-limiting embodiment of the present invention, the stripper assembly 212 further comprises a stripper ring 230. The stripper ring 230 is coupled to the stripper plate 214 for movement therewith, back and forth, in the direction “L” (Figure 2). Therefore, it is noted that both the stripper ring 230 and the neck ring slide 218 (and, therefore, the neck ring 220) are actuated in the direction “L” by the same means, i.e. by means of the stripper plate 214 (and the stripper plate

actuator, which is not depicted). It is noted that in an alternative non-limiting embodiment of the present invention, the stripper ring 230 and the neck ring slide 218 can be actuated by a separate actuator (not depicted).

5 In the specific non-limiting embodiment of the present invention depicted in Figure 2, the stripper ring 230 is coupled to the stripper plate 214 in the following manner. Defined between the stripper plate 214 and the wear plate 216 is a pocket 232. The stripper ring 230, on the other hand, comprises an annular step 234, which is complementary in shape to the pocket 232. Recalling that the wear plate 216 is coupled to the stripper plate 214 by means of bolts (not depicted), when assembled, the annular step 234 gets trapped within the pocket 232. Within the specific
10 embodiment depicted herein, the specific coupling arrangement affords a certain degree of float to the stripper ring 230, which may compensate for any mis-alignment potentially present between components of the mold stack 202. Therefore, it can be said that within this embodiment of the present invention, the stripper ring 230 is coupled to the stripper plate 214 in a floatable arrangement. However, in alternative non-limiting embodiments of the present invention, the
15 coupling between the stripper ring 230 and the stripper plate 214 can be executed by different means, such as by means of bolts or other suitable couplers (which may, but do not have to, afford the same or different degree of float to the stripper ring 230).

The stripper ring 230 includes a molding cavity defining portion 235, which in use defines a portion of the preform 210 or, more specifically, a top portion of the neck region 226, also known
20 in the art as "TSS" or "Top Sealing Surface".

According to embodiments of the present invention, the stripper ring 230 is provided with an air channel 236. The air channel 236 is in fluid communication with an air supply channel 240, which in this embodiment is defined through the wear plate 216. The air supply channel 240 is in fluid communication with a fluid source (not depicted), which is configured to provide a supply of fluid
25 (such as air, for example), which can be supplied at an operational pressure. In a specific non-limiting embodiment of the present invention, the operational pressure can be between 30 psi and 120 psi. In other embodiments of the present invention, the operational pressure can be as high as 150 psi. Other ranges are, of course possible, depending on the specific implementation.

Within the illustrated embodiment, two instances of the air channel 236 are provided, the two instances being symmetrically disposed vis-à-vis the split line between the halves of the neck rings 220. However, in alternative embodiments, a different number of the air channels 236 can be provided.

5 The air channel 236 is configured to direct a stream of so-supplied air towards the preform 210 during appropriate portions of the molding cycle. The stream of air is directed through a gap (not depicted) between core insert 206 and the stripper ring 230 towards the preform and, specifically, the top sealing surface thereof. Generally speaking, this directed stream of air can perform one or more of the following functions: (i) assisting in stripping of the preform 210 off the core insert
10 206; (ii) preventing vacuum build up or friction between the preform 210 and the core insert 206; (iii) assisting in the transfer of the preform 210 from the core insert 206 into the downstream handling device.

Within the illustrated embodiment of Figure 2, the stripper ring 230 may further include a vent groove 290 provided in an upper part of the stripper ring 230 (vis-à-vis the air channel 236). The
15 vent groove 290 can be used, in a conventional manner, for venting the molding cavity during the appropriate portion of the molding cycle.

Within the context of operation of the stripper assembly 212 presented above, operation of the stripper ring 230 will be explained in greater detail with continued reference to Figure 2 within the context of applying fluid through the air channel 236.

20 For the purposes of the description to be presented herein below, it shall be assumed that the preform 210 has been molded and has undergone in-mold cooling to a point where it is safe to demold the preform 210. At this point, the mold (not depicted) housing the mold stack 202 is unclamped and starts to open and the stripper plate actuator (not depicted) actuates the stripper plate 214 in a right-bound direction, as viewed in Figure 2. The wear plate 216, the neck ring slide
25 218, the neck ring 220 and the stripper ring 230 initially start to move, in unison, with the stripper plate 214, effectively moving the preform 210 in the right-bound direction along a portion of the complete ejection path (i.e. in the direction "L"). This portion of the complete ejection path, where the neck ring 220 and the stripper ring 230 are moving in unison can be considered to be "a first portion" of the complete ejection path.

At this point, the neck ring 220 starts to disengage from the preform 210. In other words, the intimate contact between the molding faces of the neck ring 220 and the preform 210 has been broken, but the neck ring 220 does not necessarily have to clear all portions of the neck region 226. At this point, the stream of fluid is being applied through the air channel 236.

5 A technical effect of embodiments of the present invention includes *inter alia* fewer defects associated with stripping portion of the molding cycle. Another technical effect of embodiments of the present invention may include more controlled transfer of the preform 210 into the downstream handling device.

10 It is noted that embodiments described herein above are meant as examples only. Constructions of certain components of the mold stack 202 can be varied and certain other components can be omitted altogether. For example, in certain embodiments of the present invention, the wear plate 216 can be omitted from the mold stack 202.

15 An alternative implementation of a mold stack 302 is depicted with reference to Figure 3, which depicts a cross-section view of a portion of an injection mold that incorporates the mold stack 302 being implemented in accordance with other non-limiting embodiments of the present invention. The mold stack 302 is implemented in substantially the same manner as the mold stack 202, other than for specific differences described immediately below.

20 A stripper ring 330, much akin to the stripper ring 230, comprises an air channel 336. However, unlike the air channel 236, the air channel 336 is defined much lower (i.e. more towards the left side, as viewed in Figure 3). To that extent, an air supply channel 340 is defined in a stripper plate 314 and not in a wear plate 316, which is the case within the embodiment of Figure 2. It is also noted that within the embodiment of Figure 3, a structure similar to the vent groove 290 of Figure 2 is omitted. However, in an alternative embodiment, the mold stack 302 may also include the vent groove 290.

25 Description of the non-limiting embodiments of the present inventions provides examples of the present invention, and these examples do not limit the scope of the present invention. It is to be expressly understood that the scope of the present invention is limited by the claims. The concepts described above may be adapted for specific conditions and/or functions, and may be further

extended to a variety of other applications that are within the scope of the present invention. Having thus described the non-limiting embodiments of the present invention, it will be apparent that modifications and enhancements are possible without departing from the concepts as described. Therefore, what is to be protected by way of letters patent are limited only by the scope
5 of the following claims:

What is claimed is:

1. A stripper assembly (212) for use in a mold stack (202) for forming a preform (210) suitable for blow-molding into a final-shaped container, the stripper assembly (212) comprising:
- 5 a stripper plate (214) connectable, in use, to a stripper plate actuator;
- neck rings (220) configured to cooperate to define a portion a neck region (226) of the preform (210);
- a stripper ring (230) configured to define at least a portion of a top sealing surface of the neck region (226) of the preform (210);
- 10 the stripper plate (214) being configured to actuate the neck rings (220) and the stripper ring (230), in unison, along substantially the whole length of a complete ejection path, which is substantially parallel to a longitudinal axis of the mold stack (202); and wherein
- the neck rings (220) are configured for movement in a direction substantially perpendicular to the longitudinal axis of the mold stack, over at a portion of the complete ejection path,
- 15 the stripper ring (230) having an air channel (236) configured to direct a flow of fluid towards the preform.
2. The stripper assembly (212) of claim 1, wherein the stripper ring (230) is coupled to the stripper plate (214) in a floatable arrangement.
- 20
3. The stripper assembly (212) of claim 2, wherein
- the stripper assembly (212) includes a neck ring slide (218) and the neck rings (220) are coupled to the neck ring slide (218); and wherein the stripper assembly (212) further comprises
- a wear plate (216) disposed between the stripper plate (214) and the neck ring slide (218);
- 25 and wherein, in use
- the stripper plate (214) and the wear plate (216) define a pocket (232); and wherein the stripper ring (230) comprises an annular step (234) complementary in shape to the pocket (232); and wherein, in use
- the stripper plate (214) and the wear plate (216) trap the annular step (234) within the
- 30 pocket (232).

4. The stripper assembly (212) of claim 1, wherein the stripper plate (214) is coupled, in use, to the stripper plate actuator which is configured to actuate the stripper plate (214) along the longitudinal axis of the mold stack (202).

5 5. The stripper assembly (212) of claim 1, wherein the stripper assembly (212) includes a neck ring slide (218) and the neck rings (220) are coupled to the neck ring slide (218); and wherein the neck ring slide (218) is coupled, in use, to a neck ring slide actuator and wherein the neck ring slide actuator is configured to actuate the neck ring slide (218) in a direction substantially perpendicular to the longitudinal axis of the mold stack (202).

10

6. The stripper assembly (212) of claim 1, wherein the stripper assembly (212) further comprises a wear plate (216) disposed between the stripper plate (214) and a neck ring slide (218); and wherein the wear plate (216) defines an air supply channel (240) and wherein the air channel (236) is in fluid communication with the air supply channel (240).

15

7. The stripper assembly (212) of claim 1, wherein the stripper plate (214) defines an air supply channel (340) and wherein the air channel (336) is in fluid communication with the air supply channel (240).

20

8. The stripper assembly (212) of claim 1, wherein the so-directed flow of fluid is configured to perform at least one function of: (i) assisting in stripping of the preform (210) off a core insert (206); (ii) preventing vacuum build up or friction between the preform (210) and the core insert (206); (iii) assisting in the transfer of the preform (210) from the core insert (206) into a downstream handling device.

25

9. A stripper ring (230) configured to be installed, in use, as a part of a stripper assembly (212) for use in a mold stack (202) for forming a preform (210) suitable for blow-molding into a final-shaped container, the stripper assembly including a stripper plate (214) connectable, in use, to a stripper plate actuator; neck rings (220) configured to cooperate to define a portion a neck region (226) of the preform (210); a stripper ring (230) configured to define at least a portion of a top sealing surface of the neck region (226) of the preform (210); the stripper plate (214) being configured to actuate the neck rings (220) and the stripper ring (230), in unison, along substantially the whole length of a complete ejection path, which is substantially parallel to a

30

longitudinal axis of the mold stack (202); and wherein the neck rings (220) are configured for movement in a direction substantially perpendicular to the longitudinal axis of the mold stack, over at a portion of the complete ejection path, the stripper ring (230) comprising:

5 an air channel (336) configured to direct a flow of fluid towards the preform.

10. The stripper ring (230) of claim 9, wherein the stripper ring (230) is coupled to the stripper plate (214) in a floatable arrangement.

10 11. The stripper ring (230) of claim 10, wherein
 the stripper assembly (212) includes a neck ring slide (218) and the neck rings (220) are
coupled to the neck ring slide (218); and wherein the stripper assembly (212) further comprises
 a wear plate (216) disposed between the stripper plate (214) and the neck ring slide (218);
and wherein, in use

15 the stripper plate (214) and the wear plate (216) define a pocket (232); and wherein the
stripper ring (230) comprises an annular step (234) complementary in shape to the pocket (232);
and wherein, in use

 the stripper plate (214) and the wear plate (216) trap the annular step (234) within the
pocket (232).

20 12. The stripper ring (230) of claim 9, wherein the stripper plate (214) is coupled, in use, to the
stripper plate actuator which is configured to actuate the stripper plate (214) along the
longitudinal axis of the mold stack (202).

25 13. The stripper ring (230) of claim 9, wherein the stripper assembly (212) includes a neck ring
slide (218) and the neck rings (220) are coupled to a neck ring slide (218); and wherein the neck
ring slide (218) is coupled, in use, to a neck ring slide actuator and wherein the neck ring slide
actuator is configured to actuate the neck ring slide (218) in a direction substantially
perpendicular to the longitudinal axis of the mold stack (202).

30 14. The stripper ring (230) of claim 9, wherein the stripper assembly (212) further comprises a
wear plate (216) disposed between the stripper plate (214) and the neck ring slide (218); and

wherein the wear plate (216) defines an air supply channel (240) and wherein the air channel (236) is in fluid communication with the air supply channel (240).

5 15. The stripper ring (230) of claim 9, wherein the stripper plate (214) defines an air supply channel (340) and wherein the air channel (336) is in fluid communication with the air supply channel (240).

10 16. The stripper ring (230) of claim 9, wherein the flow of fluid is configured to perform at least one function of: (i) assisting in stripping of the preform (210) off a core insert (206); (ii) preventing vacuum build up or friction between the preform (210) and the core insert (206); (iii) assisting in the transfer of the preform (210) from the core insert (206) into a downstream handling device.

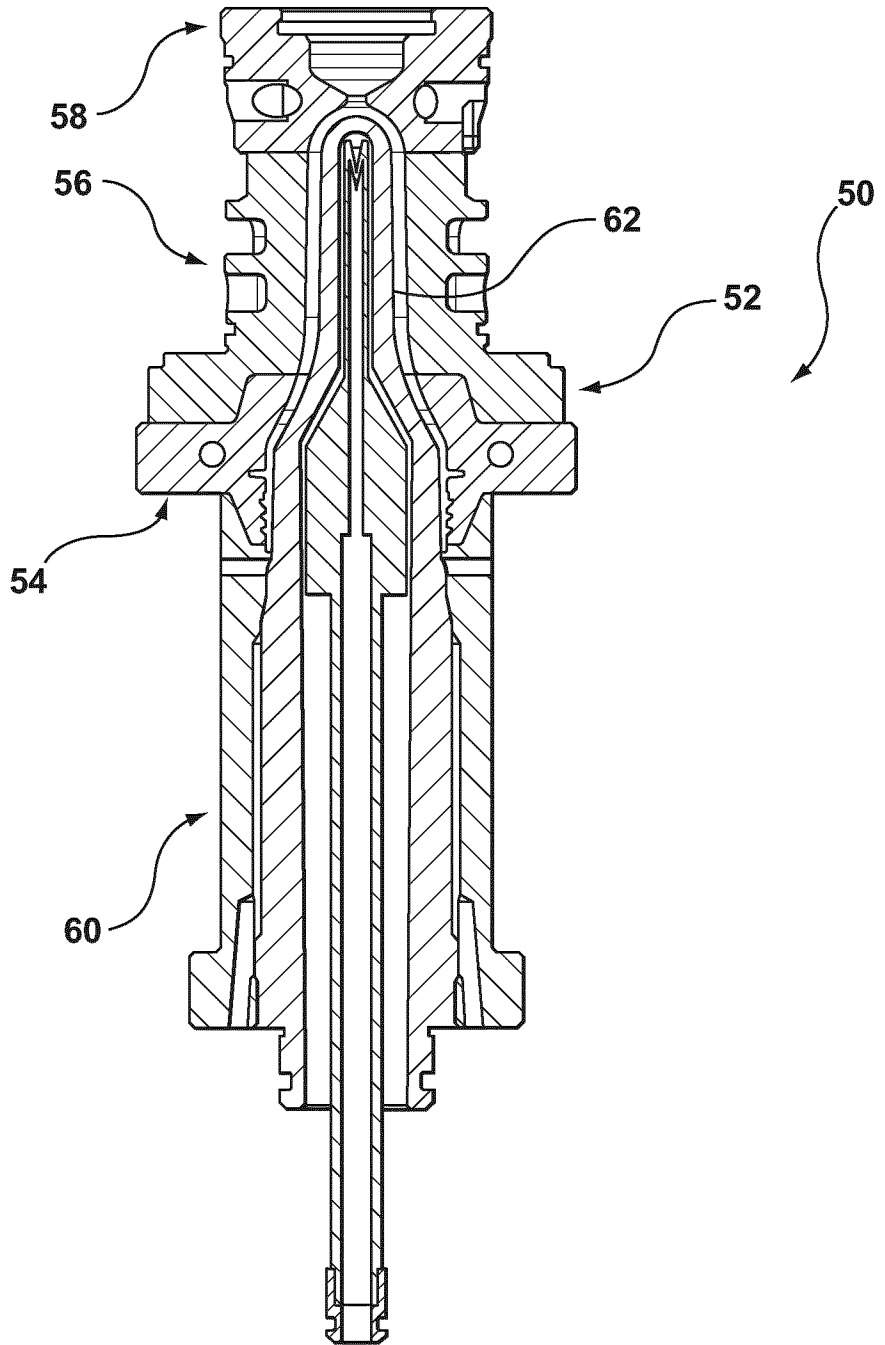

FIG. 1 (PRIOR ART)

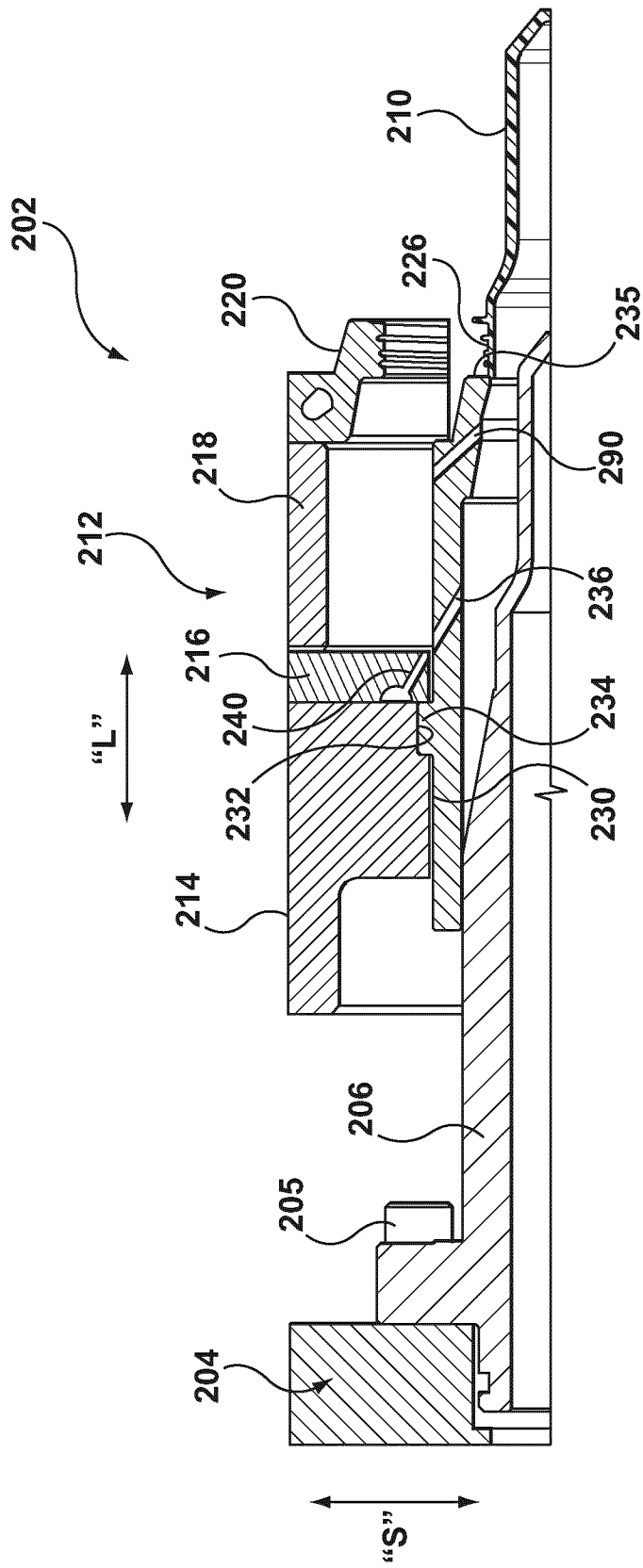

FIG. 2

3 / 3

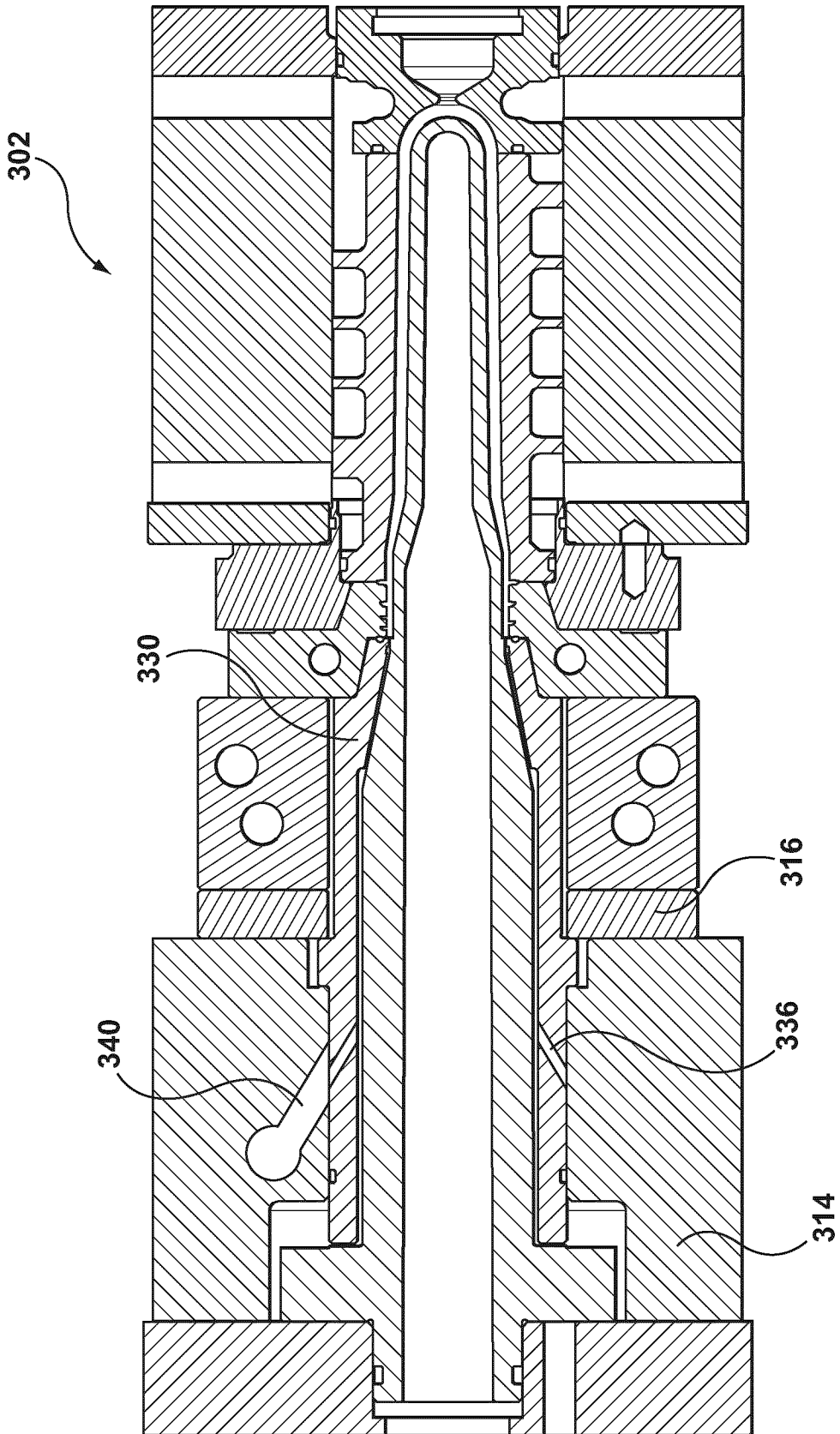

FIG. 3

INTERNATIONAL SEARCH REPORT

International application No.
PCT/CA2011/050584

A. CLASSIFICATION OF SUBJECT MATTER IPC: B29C 45/43 (2006.01) , B29B 11/08 (2006.01) According to International Patent Classification (IPC) or to both national classification and IPC		
B. FIELDS SEARCHED		
Minimum documentation searched (classification system followed by classification symbols) IPC: B29C (2006.01), B29B 11/08 (2006.01), B29D 22/00 (2006.01)		
Documentation searched other than minimum documentation to the extent that such documents are included in the fields searched		
Electronic database(s) consulted during the international search (name of database(s) and, where practicable, search terms used) EPOQUE (EPODOC and X-FULL), CPD with key words, such as: mold, mould, neck ring, split insert*, stripp* plate and air		
C. DOCUMENTS CONSIDERED TO BE RELEVANT		
Category*	Citation of document, with indication, where appropriate, of the relevant passages	Relevant to claim No.
A	WO 2010/017622 A (MCCREADY, D. R.) 18 February 2010 (18-02-2010) *whole document*	1-16
A	CA 2687287 C (MCCREADY, D. R.) 12 March 2009 (12-03-2009) *whole document*	1-16
A	CA 2547763 A1 (MARTIN, S. R.) 30 June 2005 (30-06-2005) *whole document*	1-16
<input type="checkbox"/> Further documents are listed in the continuation of Box C. <input checked="" type="checkbox"/> See patent family annex.		
* Special categories of cited documents : "A" document defining the general state of the art which is not considered to be of particular relevance "E" earlier application or patent but published on or after the international filing date "L" document which may throw doubts on priority claim(s) or which is cited to establish the publication date of another citation or other special reason (as specified) "O" document referring to an oral disclosure, use, exhibition or other means "P" document published prior to the international filing date but later than the priority date claimed "T" later document published after the international filing date or priority date and not in conflict with the application but cited to understand the principle or theory underlying the invention "X" document of particular relevance; the claimed invention cannot be considered novel or cannot be considered to involve an inventive step when the document is taken alone "Y" document of particular relevance; the claimed invention cannot be considered to involve an inventive step when the document is combined with one or more other such documents, such combination being obvious to a person skilled in the art "&" document member of the same patent family		
Date of the actual completion of the international search 18 October 2011 (18-10-2011)		Date of mailing of the international search report 29 November 2011 (29-11-2011)
Name and mailing address of the ISA/CA Canadian Intellectual Property Office Place du Portage I, C114 - 1st Floor, Box PCT 50 Victoria Street Gatineau, Quebec K1A 0C9 Facsimile No.: 001-819-953-2476		Authorized officer Pengfei Zhang (819) 953-0654

INTERNATIONAL SEARCH REPORT
Information on patent family members

International application No.
PCT/CA2011/050584

Patent Document Cited in Search Report	Publication Date	Patent Family Member(s)	Publication Date
WO 2010017622 A1	18 February 2010 (18-02-2010)	CA2730144A1 CN102112291A EP2323831A1 KR20110043751A US2011111079A1	18 February 2010 (18-02-2010) 29 June 2011 (29-06-2011) 25 May 2011 (25-05-2011) 27 April 2011 (27-04-2011) 12 May 2011 (12-05-2011)
CA 2687287 C	12 March 2009 (12-03-2009)	CN101678587A EP2197651A1 EP2197651A4 KR20100031695A US2009068307A1 US7645132B2 WO2009030018A1	24 March 2010 (24-03-2010) 23 June 2010 (23-06-2010) 03 November 2010 (03-11-2010) 24 March 2010 (24-03-2010) 12 March 2009 (12-03-2009) 12 January 2010 (12-01-2010) 12 March 2009 (12-03-2009)
CA 2547763 A1	30 June 2005 (30-06-2005)	EP1697106A1 EP1697106A4 JP2007514568A TWI268847B US2005136150A1 US7128865B2 WO2005058576A1	06 September 2006 (06-09-2006) 26 March 2008 (26-03-2008) 07 June 2007 (07-06-2007) 21 December 2006 (21-12-2006) 23 June 2005 (23-06-2005) 31 October 2006 (31-10-2006) 30 June 2005 (30-06-2005)