



(12) **EUROPEAN PATENT APPLICATION**

(43) Date of publication:
29.03.2017 Bulletin 2017/13

(51) Int Cl.:
F01D 11/00^(2006.01) F01D 11/12^(2006.01)

(21) Application number: **15186492.3**

(22) Date of filing: **23.09.2015**

(84) Designated Contracting States:
AL AT BE BG CH CY CZ DE DK EE ES FI FR GB GR HR HU IE IS IT LI LT LU LV MC MK MT NL NO PL PT RO RS SE SI SK SM TR
 Designated Extension States:
BA ME
 Designated Validation States:
MA

(72) Inventors:
 • **Simon-Delgado, Carlos**
5400 Baden (CH)
 • **Sommer, Christian**
5415 Nussbaumen (CH)
 • **Bricaud, Cyrille**
79618 Rheinfelden (DE)

(71) Applicant: **General Electric Technology GmbH**
5400 Baden (CH)

(74) Representative: **Bernotti, Andrea et al**
Studio Torta S.p.A.
Via Viotti, 9
10121 Torino (IT)

(54) **AXIAL FLOW TURBINE**

(57) The present invention generally relates to an axial flow turbine crossed by an axial main flow and wherein a leakage flow, which typically passes through a radial tip clearance provided between a stator part and a rotor

part, has an improved incidence when it merges with the main flow downstream the radial tip. In this way, aerodynamic losses are reduced and the energy conversion process is enhanced.

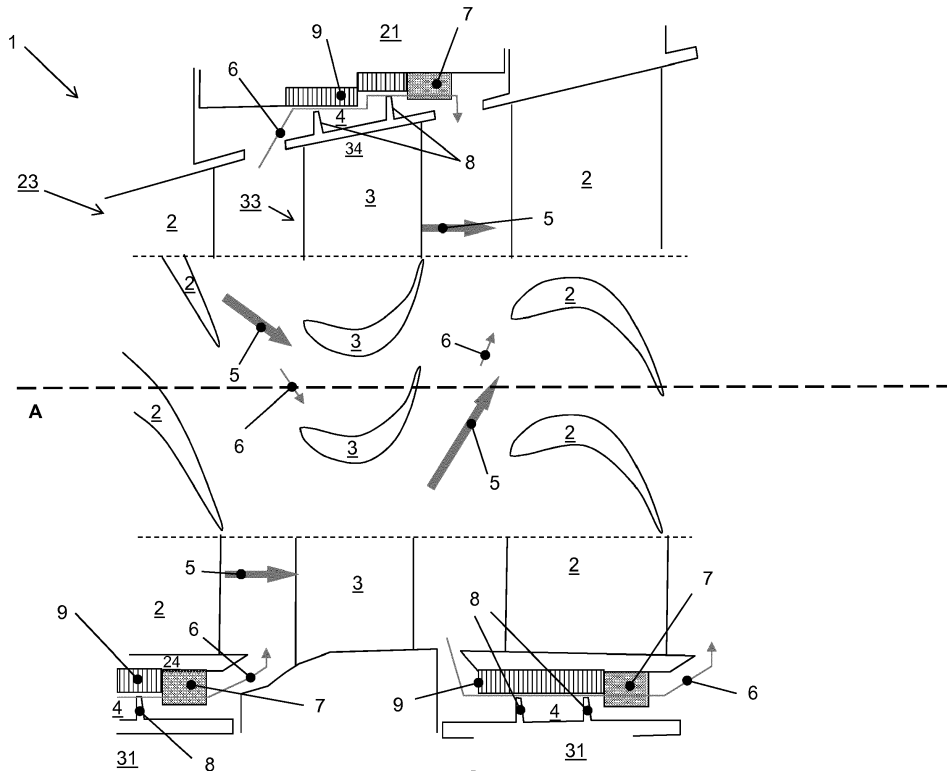

FIG. 2

Description

TECHNICAL FIELD

[0001] The present invention generally relates to an axial flow turbine crossed by an axial main flow and wherein a leakage flow, which typically passes through a radial tip clearance provided between a stator part and a rotor part, has an improved incidence when it merges with the main flow downstream the radial tip. In this way, aerodynamic losses are reduced and the energy conversion process is enhanced.

BACKGROUND

[0002] As well known, an axial flow turbine is made of a plurality of stages arranged through its axial development, each one comprising a stator part followed by a rotor part. The stator parts include vanes which are fitted within a carrier, whilst the rotor parts include blades integral to a rotating shaft which is supported by the carrier. Generally, the interaction between the hot gas axially flowing through the machine and the rotor parts causes the shaft to rotate. The shaft rotation may then be utilized for the production of electrical energy or for the generation of a thrust in a jet engine of an aircraft.

Due to the high speed rotation of the rotor shaft, a radial tip clearance is provided between stator parts and the rotor parts.

However, a portion of the main flow leaks through the radial clearance avoiding the interaction with the stator parts or the rotor parts. Disadvantageously, when the leakage flow merges with the main flow, downstream the radial tip, it is characterised by an incident angle with respect to the main flow which causes important aerodynamic losses and thus reduces the efficiency of the overall energy conversion process.

SUMMARY OF THE INVENTION

[0003] It is an object of the present invention to solve the aforementioned technical problem by providing an axial flow turbine as substantially defined according to independent claim 1.

[0004] According to an aspect of the invention, this object is achieved by an axial flow turbine comprising a stator part and a rotor part between which a radial tip clearance is provided, wherein a main flow crosses the turbine and a leakage flow passes through the radial tip clearance during operation of the turbine, and wherein a deflector is arranged downstream the radial tip clearance and is configured to confer a swirl to the leakage flow.

[0005] According to a preferred aspect of the invention, the deflector is adapted to substantially align a direction of the leakage flow exiting the radial tip clearance to a direction of the main flow exiting the stator or rotor part.

[0006] According to a preferred aspect of the invention, the stator and/or the rotor part comprises one or more

fins radially protruding within the clearance.

[0007] According to a preferred aspect of the invention, the axial flow turbine further comprises an abradable element disposed within the tip clearance facing the one or more fins and mounted on the stator part.

[0008] According to a preferred aspect of the invention, the one or more fins comprise a downstream fin located in the proximity of an exit of the radial tip clearance.

[0009] According to a preferred aspect of the invention, the deflector is arranged at the exit of the radial tip clearance in the proximity of the downstream fin.

[0010] According to a preferred aspect of the invention, the deflector is mounted on the stator part and the one or more fins are mounted on the rotor part.

[0011] According to a preferred aspect of the invention, the deflector is mounted on the rotor part and the one or more fins are mounted on the stator part.

[0012] According to a preferred aspect of the invention, the deflector comprises one or more deflecting elements equally positioned along a circumferential development of the stator part or the rotor part.

[0013] According to a preferred aspect of the invention, the one or more deflecting elements are airfoil-shaped.

BRIEF DESCRIPTION OF THE DRAWINGS

[0014] The objects, advantages and other features of the present invention will become more apparent upon reading of the following non-restrictive description of preferred embodiments thereof, given for the purpose of exemplification only, with reference to the accompany drawing, through which similar reference numerals may be used to refer to similar elements, and in which:

Figure 1 schematically shows a mixed lateral section view and a top section view of a turbine according to the prior art;

Figure 2 schematically shows a mixed lateral section view and a top section view of a turbine according to the present invention;

Figure 3 shows a particular of figure 2 and a bottom-to-top view along a section line B-B'.

[0015] An exemplary preferred embodiment will be now described with reference to the aforementioned drawings.

DETAILED DESCRIPTION OF THE INVENTION

[0016] With reference to figure 1, it is shown an axial flow turbine 100 according to the prior art. Turbine 100 includes a vane carrier, generally indicated with numeral reference 21, to which a plurality of stator vanes 2 is integrally fitted. Turbine 100 further includes a rotor shaft 31, to which a plurality of rotor blades 3 is connected. In the following description, it is generally intended that a stator part 23 includes the stator vane 2, the vane carrier 21 and the necessary means for connecting the stator

vane 2 to the vane carrier 21. For example, the stator part 23 includes a vane shroud 22 which is supported by the carrier 21. Similarly, it is generally intended that a rotor part 33 includes the rotor blade 3, the rotor shaft 31 and the necessary means for connecting the rotor blade to the rotor shaft 31. For example, rotor part 33 also includes a rotor blade hub with platform and shank 32. Turbine 100 comprises a plurality of stages, arranged along an axis **A**, each one made by a stator part 23 followed by a rotor part 33. The stator vanes 2 are equally arranged along a circumferential development of the carrier 21, whilst the rotor blades 33 are arranged along a circumferential development of the rotor shaft 31. With reference to the figure, it is shown a schematic lateral section of the turbine 100 showing a first stage comprising a stator part 23 followed by a rotor part 33. It is also shown a stator vane 2 of a subsequent stage.

Moreover, figure 1 shows along a central portion, a top section of the axial turbine 100, showing a row of airfoil-shaped stator vanes 2 followed by a row of airfoil-shaped rotor blades 3.

Stator vane 2 comprises a tip portion 24 which faces the rotor shaft 31. A radial tip clearance 4 is provided between the stator vane 2 and the rotor shaft 31. An abradable element 9 is located on the stator tip portion 24, in order to minimize the clearance 4. In fact, the abradable element 9 can tolerate contact which may occur between the rotating shaft 31 and the stator vane 2. Similarly, an abradable element 9 is provided on the carrier 21 which faces a tip portion 34 of the rotor blade 3.

The following description will be now directed to a single stage of the turbine 100, but it will be appreciated that the same will also apply to every stage.

Turbine 100 is crossed, during operation, by a main flow of hot gas 5. However, a portion of the main flow 5 leaks through the radial tip clearances 4 due to a favourable pressure gradient. As a consequence, a leakage flow, indicated with numeral reference 6, is not guided by the stator vanes 2 and does not receive the optimum swirl necessary to have the correct incidence when approaching the rotor blades 3. As a result, when the leakage flow 6 exits the radial tip clearance 4 and merges with the main flow 5, it is oriented in such a way to impact the main flow 5 creating a negative effect on its incidence towards rotor blades 3. The same occurrence is experienced by the main flow exiting the rotor blades row 3.

To minimize this negative effect, fins 8 radially protruding into the radial tip clearances 4 are provided on the rotor shaft 31, facing the stator vane 2, and on the carrier 21 facing the rotor blades 3. In the example shown, fins 8 comprise an upstream fin and a downstream fin, the latter being positioned in the proximity of an exit of the radial tip clearance 4, but it will be appreciated that only one fin may be provided in the tip clearance.

The presence of the fins 8 creates a barrier for preventing a leakage flow to go through the clearance 4, this way bypassing the stator parts 23 or the rotor parts 32. However, despite the fins 8, during normal operation the leak-

age flow 6 still passes through the clearance 4 creating the negative effect on the incidence of the main flow 5 approaching a stator vane 2 or a rotor blade 3, as above explained.

5 **[0017]** Making now reference to next figure 2 it is shown, in the same schematic views as for figure 1, an axial flow turbine 1 according to the present invention.

Turbine 1 differs from the turbine according to the prior art in that it comprises a deflector 7 which is arranged downstream the radial tip clearance 4, preferably in the proximity of an exit thereof, and it is configured to confer a swirl to the leakage flow 6.

10 More in particular, with reference to the turbine stage here described, as clearly shown in the figure by the arrows of the main flow 5 and leakage flow 6, the deflector 7 located on the tip portion 24 of the stator vane 2 is adapted to substantially align a direction of the leakage flow 6 exiting the radial tip clearance 4 to a direction of the main flow 5 exiting the stator vanes row 2.

15 Similarly, the deflector 7 located on the carrier 21 facing the rotor blade 3, is adapted to substantially align a direction of the leakage flow 6 exiting the radial tip clearance 4 to a direction of the main flow 5 exiting the rotor blades row 3.

20 According to a preferred embodiment, the deflector 7 is arranged substantially at the exit of the radial tip clearance in the proximity of the downstream fin. The closer the deflector 7 is to the fin 8, then the better result is achieved in terms of conferring the wished swirl to the leakage flow before it joins the main flow 5.

25 In the exemplary and non-limiting embodiment herewith described, the deflector 7 is mounted on the stator part 23, and specifically on the stator vane 2 and on the carrier 21, whilst the fins 8 are mounted on the rotor part 33, and respectively on the rotor shaft 31 and on the tip portion 34 of the rotor blade 34.

30 It will be appreciated that, according to a variant of this embodiment, the deflector 7 may also be mounted on the rotor part 33, and specifically on the rotor shaft 31 and on the rotor blade 3, whilst the fins 8 may also be mounted on the stator part 23, and respectively on the tip portion 24 of the stator vane 2 and on the carrier 21.

35 **[0018]** Turning to last figure 3, it is exemplary shown the radial tip clearance 4 formed between the stator vane 2 and the rotor shaft 31. The deflector 7 is positioned in the proximity of the downstream fin 8 in a way to deflect the leakage flow 6. In particular, figure 3 shows a bottom-to-top view along section line B-B'. In this view, deflector 7 is visible as a plurality of deflecting elements 71 which are equally positioned along a circumferential development of the stator part 23. In the figure it is shown that deflecting elements 71 confer to the leakage flow lines 6 a swirl which is similar to the one operated by the stator vanes 2. In this way, when leakage flow 6 and the main flow 5 merge, they are substantially aligned and hence the incidence of the latter approaching the subsequent rotor blade row is effectively improved.

40 Preferably, the deflecting elements 71 are airfoil-shaped.

[0019] While the invention has been described in detail in connection with only a limited number of embodiments, it should be readily understood that the invention is not limited to such disclosed embodiments. Rather, the invention can be modified to incorporate any number of variations, alterations, substitutions or equivalent arrangements not heretofore described, but which are commensurate with the spirit and scope of the invention. Additionally, while various embodiments of the invention have been described, it is to be understood that aspects of the invention may include only some of the described embodiments. Accordingly, the invention is not to be seen as limited by the foregoing description, but is only limited by the scope of the appended claims.

Claims

1. Axial flow turbine (1) comprising a stator part (23) and a rotor part (33) between which a radial tip clearance (4) is provided, wherein a main flow (5) crosses said turbine (1) and a leakage flow (6) passes through said radial tip clearance (4) during operation of the turbine (1), the turbine (1) being ***characterised in that*** it comprises a deflector (7) arranged downstream said radial tip clearance (4) and configured to confer a swirl to said leakage flow (6).
2. Axial flow turbine (1) according to the preceding claim, wherein said deflector (7) is adapted to substantially align a direction of the leakage flow (6) exiting said radial tip clearance (4) to a direction of the main flow (5) exiting said stator or rotor part (23, 33).
3. Axial flow turbine (1) according to any of the preceding claims, wherein said stator and/or rotor part (23, 33) comprise one or more fins (8) radially protruding within said radial tip clearance (4).
4. Axial flow turbine (1) according to the preceding claim, wherein said one or more fins (8) comprise a downstream fin (8) located in the proximity of an exit of said radial tip clearance (4).
5. Axial flow turbine (1) according to the preceding claim, further comprising an abradable element (9) disposed within said tip radial tip clearance (4) facing said one or more fins (8) and mounted on said stator part (23).
6. Axial flow turbine (1) according to claims 4 or 5, wherein said deflector (7) is arranged at the exit of said radial tip clearance (4) in the proximity of said downstream fin (8).
7. Axial flow turbine (1) according to any of claims 3 - 6, wherein said deflector (7) is mounted on said stator part (23) and said one or more fins (8) are mounted on said rotor part (33).
8. Axial flow turbine (1) according to any of claims 3 - 6, wherein said deflector (7) is mounted on said rotor part (33) and said one or more fins (8) are mounted on said stator part (23).
9. Axial flow turbine (1) according to any of the preceding claims, wherein said deflector (7) comprises one or more deflecting elements (71) equally positioned along a circumferential development of said stator part (23) or said rotor part (33).
10. Axial flow turbine (1) according to the preceding claim, wherein said one or more deflecting elements (71) are airfoil-shaped.

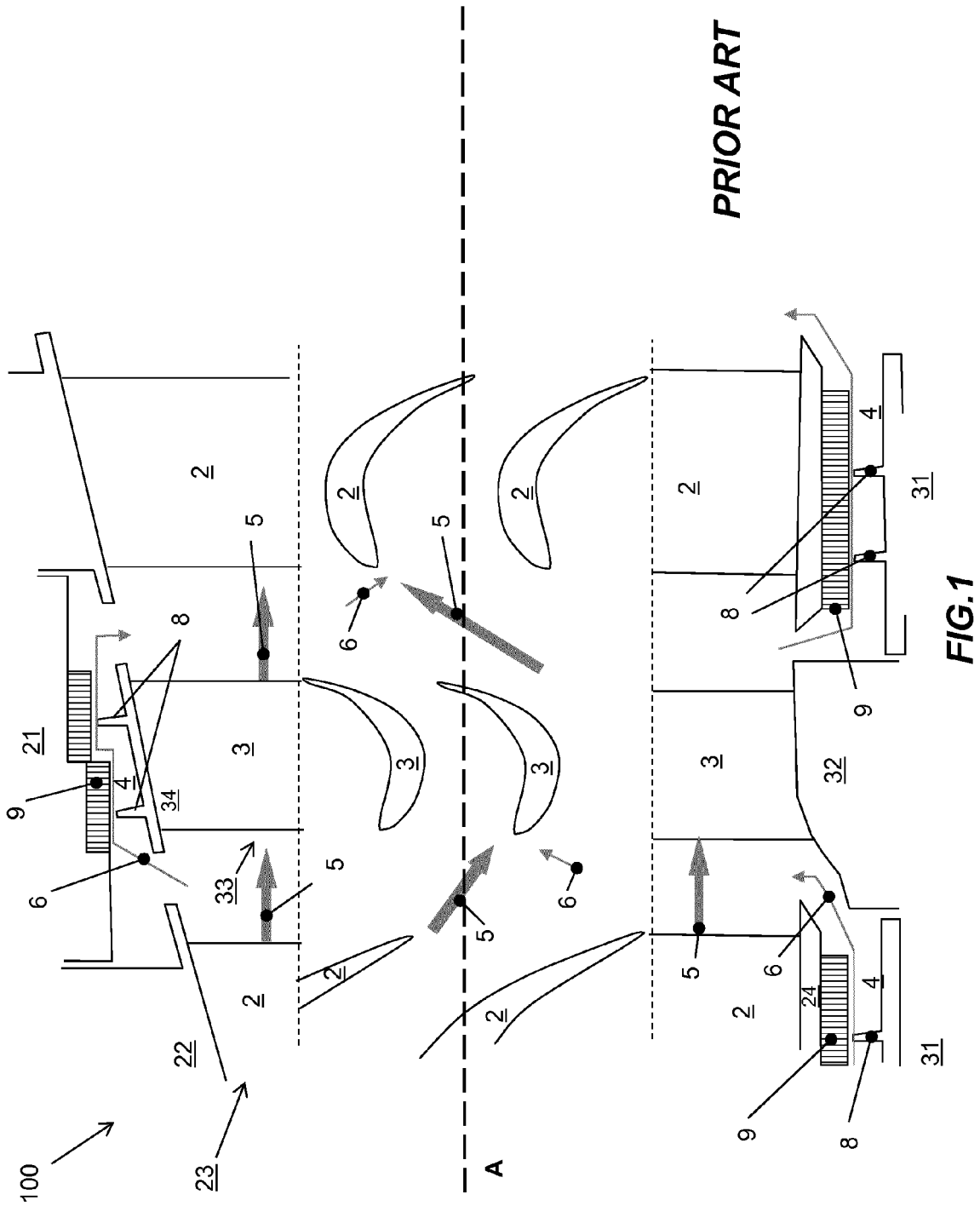

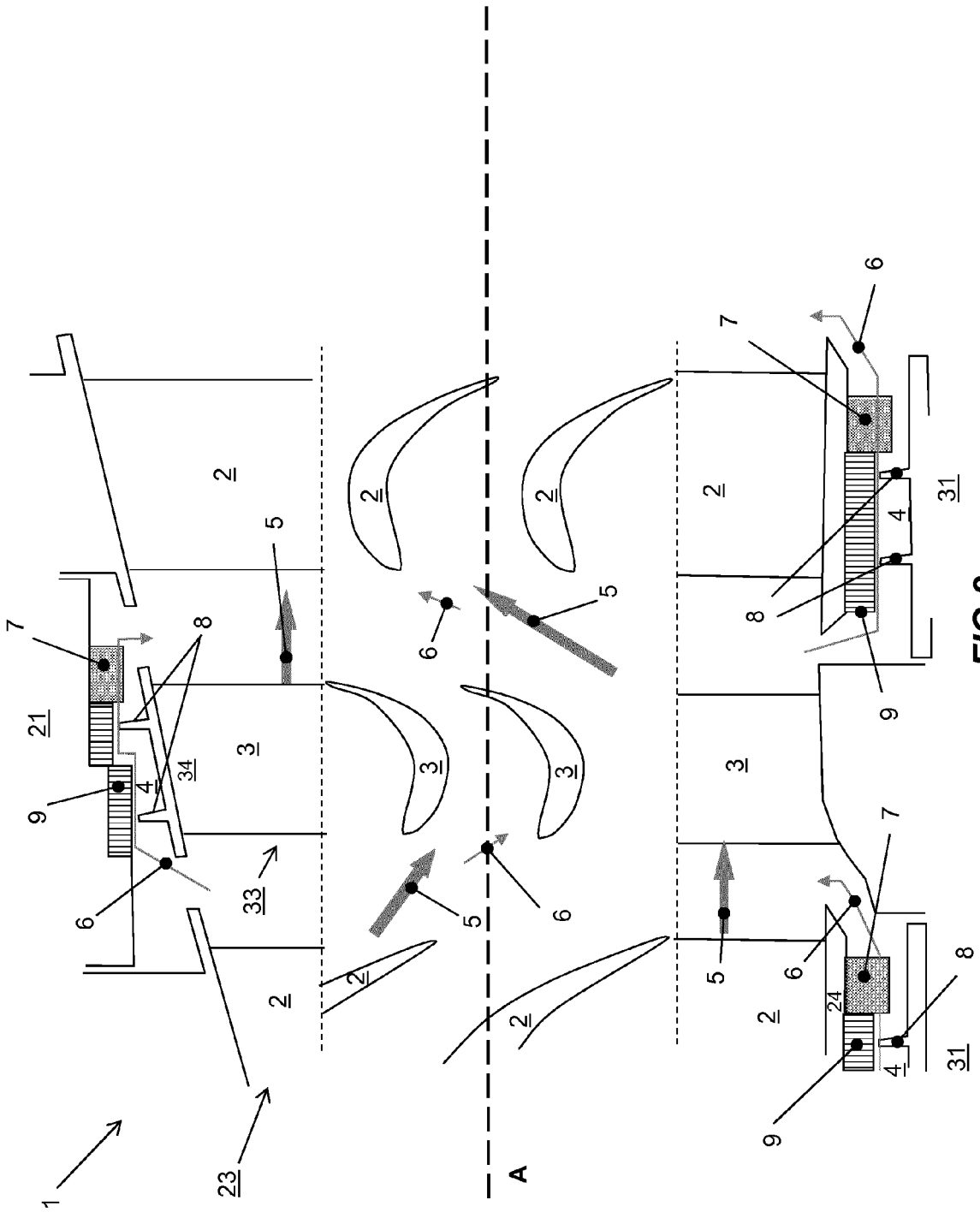

FIG. 2

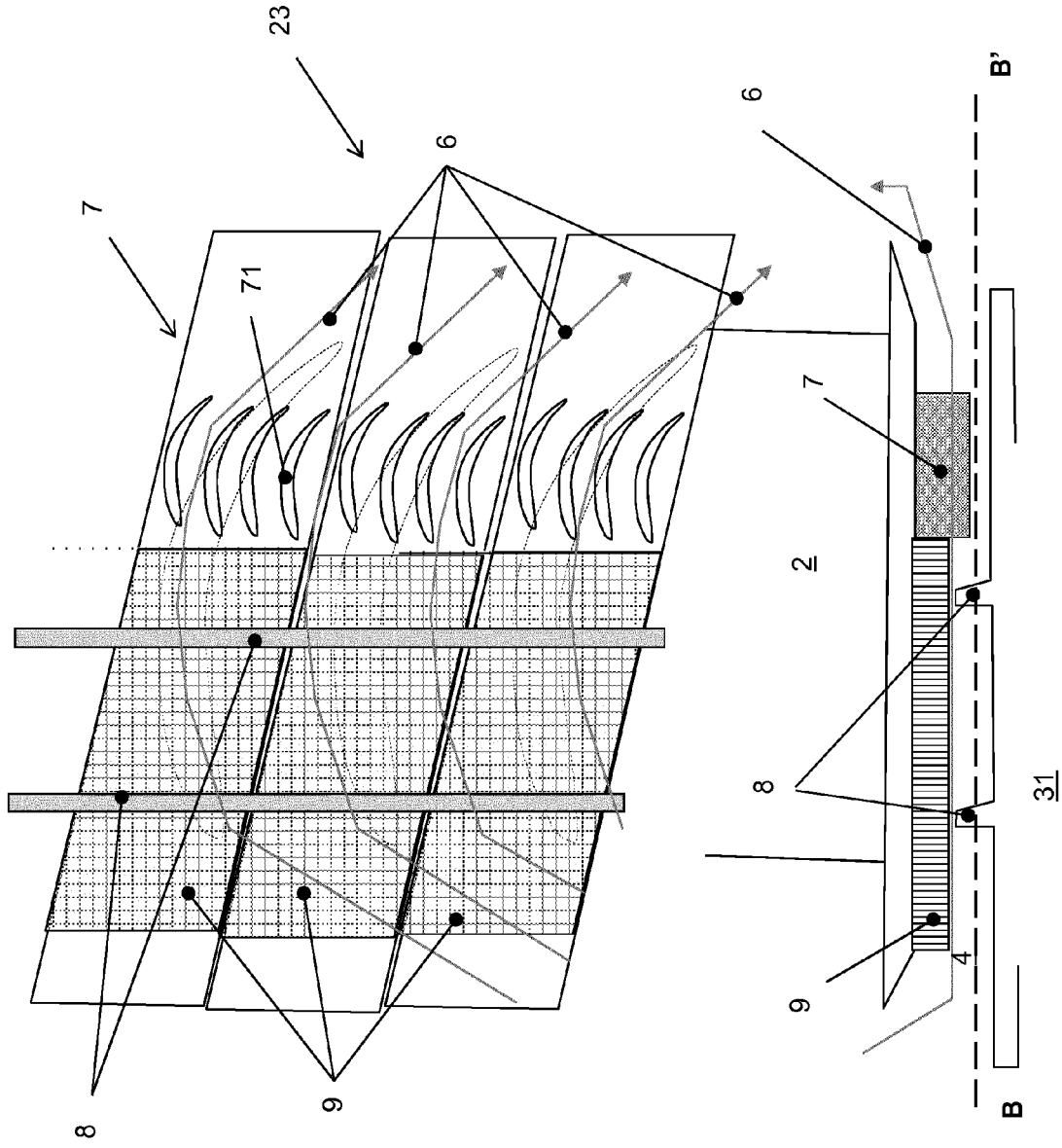

FIG.3



EUROPEAN SEARCH REPORT

Application Number
EP 15 18 6492

5

10

15

20

25

30

35

40

45

DOCUMENTS CONSIDERED TO BE RELEVANT			
Category	Citation of document with indication, where appropriate, of relevant passages	Relevant to claim	CLASSIFICATION OF THE APPLICATION (IPC)
X	DE 35 23 469 A1 (BBC BROWN BOVERI & CIE [CH]) 8 January 1987 (1987-01-08)	1-4,6-10	INV. F01D11/00 F01D11/12
Y	* figures 1-3 * * column 2, line 29 - line 42 * * column 3, line 47 - column 4, line 45 *	5	
X	US 2013/230379 A1 (ALI SULFICKER [IN]) 5 September 2013 (2013-09-05)	1-4,6,8,9	TECHNICAL FIELDS SEARCHED (IPC) F01D
Y	* figures 1-6 * * page 2, paragraph [0017] - paragraph [0020] *	5	
X	WO 2011/029420 A1 (MTU AERO ENGINES GMBH [DE]; KRAUS JUERGEN [DE]; MAHLE INGA [DE]) 17 March 2011 (2011-03-17)	1-4,6,7,9	F01D
Y	* figures 1, 7, 8 * * page 8, line 13 - page 10, line 3 *	5	
X	JP 2007 321721 A (TOSHIBA CORP) 13 December 2007 (2007-12-13)	1-4,6,8,9	F01D
Y	* figures 1-11 * * paragraph [[0015]] - paragraph [[0024]] *	5	
X	US 2013/189107 A1 (KRISHNAN PRABAKARAN MODACHUR [IN] ET AL) 25 July 2013 (2013-07-25)	1-4,6,7,9,10	F01D
Y	* figures 1-3, 5-7 * * page 1, paragraph [0018] - page 2, paragraph [0028] *	5	
X	US 881 474 A (JUDE ALEXANDER [GB]) 10 March 1908 (1908-03-10)	1-3,7-9	F01D
Y	* figures 1, 2 * * page 1, line 62 - page 2, line 6 *	5	
----- -/--			
The present search report has been drawn up for all claims			
Place of search Munich		Date of completion of the search 2 March 2016	Examiner Lutoschkin, Eugen
CATEGORY OF CITED DOCUMENTS X : particularly relevant if taken alone Y : particularly relevant if combined with another document of the same category A : technological background O : non-written disclosure P : intermediate document T : theory or principle underlying the invention E : earlier patent document, but published on, or after the filing date D : document cited in the application L : document cited for other reasons & : member of the same patent family, corresponding document			

EPO FORM 1503 03/82 (P04/C01)

1

50

55



EUROPEAN SEARCH REPORT

Application Number
EP 15 18 6492

5

10

15

20

25

30

35

40

45

50

55

DOCUMENTS CONSIDERED TO BE RELEVANT			
Category	Citation of document with indication, where appropriate, of relevant passages	Relevant to claim	CLASSIFICATION OF THE APPLICATION (IPC)
X	GB 2 110 767 A (ROLLS ROYCE) 22 June 1983 (1983-06-22) * figures 1-3 * * page 1, line 74 - page 2, line 86 * -----	1,2,9,10	
X	JP S57 8302 A (HITACHI LTD) 16 January 1982 (1982-01-16) * abstract; figures 7-12 *	1-4,6,9	
Y		5	
Y	WO 2004/113770 A2 (ELLIOTT CO [US]; LI JIMING [US]; DE CHOUDHURY PRANABESH [US]) 29 December 2004 (2004-12-29) * figures 1, 2 * -----	5	
			TECHNICAL FIELDS SEARCHED (IPC)
The present search report has been drawn up for all claims			
Place of search Munich		Date of completion of the search 2 March 2016	Examiner Lutoschkin, Eugen
CATEGORY OF CITED DOCUMENTS X : particularly relevant if taken alone Y : particularly relevant if combined with another document of the same category A : technological background O : non-written disclosure P : intermediate document		T : theory or principle underlying the invention E : earlier patent document, but published on, or after the filing date D : document cited in the application L : document cited for other reasons & : member of the same patent family, corresponding document	

EPO FORM 1503 03/02 (P04C01)

ANNEX TO THE EUROPEAN SEARCH REPORT
ON EUROPEAN PATENT APPLICATION NO.

EP 15 18 6492

5 This annex lists the patent family members relating to the patent documents cited in the above-mentioned European search report.
The members are as contained in the European Patent Office EDP file on
The European Patent Office is in no way liable for these particulars which are merely given for the purpose of information.

02-03-2016

Patent document cited in search report	Publication date	Patent family member(s)	Publication date
DE 3523469 A1	08-01-1987	NONE	
US 2013230379 A1	05-09-2013	CN 103291376 A DE 102013101902 A1 GB 2501169 A JP 2013181543 A RU 2013108927 A US 2013230379 A1	11-09-2013 05-09-2013 16-10-2013 12-09-2013 10-09-2014 05-09-2013
WO 2011029420 A1	17-03-2011	DE 102009040758 A1 WO 2011029420 A1	17-03-2011 17-03-2011
JP 2007321721 A	13-12-2007	NONE	
US 2013189107 A1	25-07-2013	CN 103216276 A EP 2620595 A1 JP 2013151935 A RU 2013102781 A US 2013189107 A1	24-07-2013 31-07-2013 08-08-2013 27-07-2014 25-07-2013
US 881474 A	10-03-1908	NONE	
GB 2110767 A	22-06-1983	NONE	
JP S578302 A	16-01-1982	JP S578302 A JP S6133968 B2	16-01-1982 05-08-1986
WO 2004113770 A2	29-12-2004	US 2006237914 A1 WO 2004113770 A2	26-10-2006 29-12-2004