

(19) World Intellectual Property Organization
International Bureau



(43) International Publication Date
14 May 2010 (14.05.2010)

(10) International Publication Number
WO 2010/054014 A1

(51) International Patent Classification:
G06F 3/041 (2006.01)

(21) International Application Number:
PCT/US2009/063307

(22) International Filing Date:
4 November 2009 (04.11.2009)

(25) Filing Language: English

(26) Publication Language: English

(30) Priority Data:
61/111,316 4 November 2008 (04.11.2008) US
61/111,329 4 November 2008 (04.11.2008) US

(71) Applicant (for all designated States except US): **ARTIFICIAL MUSCLE, INC.** [US/US]; 749 North Mary Avenue, Sunnyvale, CA 94085 (US).

(72) Inventors; and

(75) Inventors/Applicants (for US only): **ZARRABI, Alireza** [US/US]; 1097b Alta Mira Drive, Santa Clara, CA 95051 (US). **WEABER, Chris, A.** [US/US]; 1350 Main Street,

Montara, CA 94037 (US). **POLYAKOV, Ilya** [US/US]; 1421 10th Avenue #102, San Francisco, CA 94122 (US). **HITCHCOCK, Roger** [US/US]; 1614 Graff Avenue, San Leandro, CA 94577 (US).

(74) Agents: **HAN, Johny, U.** et al.; Levine Bagade Han LLP, 2400 Geng Road, Suite 120, Palo Alto, CA 94303 (US).

(81) Designated States (unless otherwise indicated, for every kind of national protection available): AE, AG, AL, AM, AO, AT, AU, AZ, BA, BB, BG, BH, BR, BW, BY, BZ, CA, CH, CL, CN, CO, CR, CU, CZ, DE, DK, DM, DO, DZ, EC, EE, EG, ES, FI, GB, GD, GE, GH, GM, GT, HN, HR, HU, ID, IL, IN, IS, JP, KE, KG, KM, KN, KP, KR, KZ, LA, LC, LK, LR, LS, LT, LU, LY, MA, MD, ME, MG, MK, MN, MW, MX, MY, MZ, NA, NG, NI, NO, NZ, OM, PE, PG, PH, PL, PT, RO, RS, RU, SC, SD, SE, SG, SK, SL, SM, ST, SV, SY, TJ, TM, TN, TR, TT, TZ, UA, UG, US, UZ, VC, VN, ZA, ZM, ZW.

(84) Designated States (unless otherwise indicated, for every kind of regional protection available): ARIPO (BW, GH,

[Continued on next page]

(54) Title: ELECTROACTIVE POLYMER TRANSDUCERS FOR TACTILE FEEDBACK DEVICES

(57) Abstract: Electroactive transducers as well as methods of producing a haptic effect in a user interface device simultaneously with a sound generated by a separately generated audio signal and electroactive polymer transducers for sensory feedback applications in user interface devices are disclosed.

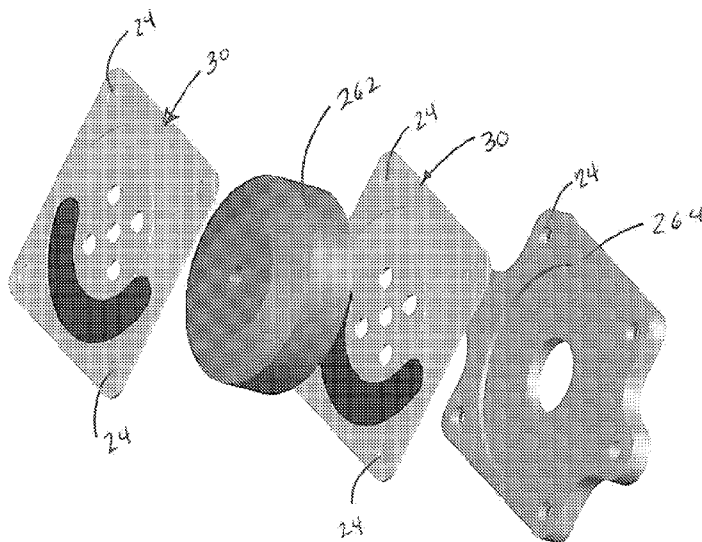

Fig . 27B

WO 2010/054014 A1

GM, KE, LS, MW, MZ, NA, SD, SL, SZ, TZ, UG, ZM, ZW), Eurasian (AM, AZ, BY, KG, KZ, MD, RU, TJ, TM), European (AT, BE, BG, CH, CY, CZ, DE, DK, EE, ES, FI, FR, GB, GR, HR, HU, IE, IS, IT, LT, LU, LV, MC, MK, MT, NL, NO, PL, PT, RO, SE, SI, SK, SM,

TR), OAPI (BF, BJ, CF, CG, CI, CM, GA, GN, GQ, GW, ML, MR, NE, SN, TD, TG).

Published:

— with international search report (Art. 21(3))

ELECTROACTIVE POLYMER TRANSDUCERS FOR TACTILE FEEDBACK DEVICES

RELATED APPLICATION

[0001] The present application is a non-provisional of U.S. Provisional Application No. 61/111,316 filed November 4, 2008 entitled "ELECTRO ACTIVE POLYMER TRANSDUCERS FOR HAPTIC FEEDBACK" and U.S. Provisional Application No. 61/111,319 filed November 4, 2008 entitled "FILTER SOUND DRIVE WAVEFORM FOR EPAM HAPTICS AND EPAM ACTUATION PASSIVE FILM COUPLING" the entirety of which is incorporated by reference.

FIELD OF THE INVENTION

[0002] The present invention is directed to the use of electroactive polymer transducers to provide sensory feedback.

BACKGROUND

[0003] A tremendous variety of devices used today rely on actuators of one sort or another to convert electrical energy to mechanical energy. Conversely, many power generation applications operate by converting mechanical action into electrical energy. Employed to harvest mechanical energy in this fashion, the same type of actuator may be referred to as a generator. Likewise, when the structure is employed to convert physical stimulus such as vibration or pressure into an electrical signal for measurement purposes, it may be characterized as a sensor. Yet, the term "transducer" may be used to generically refer to any of the devices.

[0004] A number of design considerations favor the selection and use of advanced dielectric elastomer materials, also referred to as "electroactive polymers" (EAPs), for the fabrication of transducers. These considerations include potential force, power density, power conversion/consumption, size, weight, cost, response time, duty cycle, service requirements, environmental impact, etc. As such, in many applications, EAP technology offers an ideal replacement for piezoelectric, shape-memory alloy (SMA) and electromagnetic devices such as motors and solenoids.

[0005] Examples of EAP devices and their applications are described in U.S. Patent Nos. 7,394,282; 7,378,783; 7,368,862; 7,362,032; 7,320,457; 7,259,503; 7,233,097; 7,224,106; 7,211,937; 7,199,501; 7,166,953; 7,064,472; 7,062,055; 7,052,594; 7,049,732; 7,034,432; 6,940,221; 6,911,764; 6,891,317; 6,882,086; 6,876,135; 6,812,624; 6,809,462; 6,806,621; 6,781,284; 6,768,246; 6,707,236; 6,664,718; 6,628,040; 6,586,859; 6,583,533; 6,545,384; 6,543,110; 6,376,971 and 6,343,129; and in U.S. Patent Application Publication Nos.

2008/0157631; 2008/0116764; 2008/0022517; 2007/0230222; 2007/0200468; 2007/0200467; 2007/0200466; 2007/0200457; 2007/0200454; 2007/0200453; 2007/0170822; 2006/0238079; 2006/0208610; 2006/0208609; and 2005/0157893, and U.S. patent application no. 12/358,142 filed on January 22, 2009; and PCT Publication No. W0 2009/067708 the entireties of which are incorporated herein by reference.

[0006] An EAP transducer comprises two electrodes having deformable characteristics and separated by a thin elastomeric dielectric material. When a voltage difference is applied to the electrodes, the oppositely-charged electrodes attract each other thereby compressing the polymer dielectric layer therebetween. As the electrodes are pulled closer together, the dielectric polymer film becomes thinner (the z-axis component contracts) as it expands in the planar directions (along the x- and y-axes), i.e., the displacement of the film is in-plane. The EAP film may also be configured to produce movement in a direction orthogonal to the film structure (along the z-axis), i.e., the displacement of the film is out-of-plane. U.S. Patent Application Serial No. 2005/0157893 discloses EAP film constructs which provide such out-of-plane displacement – also referred to as surface deformation or thickness mode deflection.

[0007] The material and physical properties of the EAP film may be varied and controlled to customize the surface deformation undergone by the transducer. More specifically, factors such as the relative elasticity between the polymer film and the electrode material, the relative thickness between the polymer film and electrode material and/or the varying thickness of the polymer film and/or electrode material, the physical pattern of the polymer film and/or electrode material (to provide localized active and inactive areas), and the tension or pre-strain placed on the EAP film as a whole, and the amount of voltage applied to or capacitance induced upon the film may be controlled and varied to customize the surface features of the film when in an active mode.

[0008] Numerous transducer-based applications exist which would benefit from the advantages provided by such surface deformation EAP films. One such application includes the use of EAP films to produce haptic feedback (the communication of information to a user through forces applied to the user's body) in user interface devices. There are many known user interface devices which employ haptic feedback, typically in response to a force initiated by the user. Examples of user interface devices that may employ haptic feedback include keyboards, touch screens, computer mice, trackballs, stylus sticks, joysticks, etc. The haptic feedback provided by these types of interface devices is in the form of physical sensations, such as vibrations, pulses, spring forces, etc., which a user senses either directly (e.g., via touching of the screen), indirectly (e.g., via a vibrational effect such as when a cell phone vibrates in a purse or bag) or otherwise sensed (e.g., via an

action of a moving body that creates a pressure disturbance but does not generate an audio signal in the traditional sense).

[0009] Often, a user interface device with haptic feedback can be an input device that “receives” an action initiated by the user as well as an output device that provides haptic feedback indicating that the action was initiated. In practice, the position of some contacted or touched portion or surface, e.g., a button, of a user interface device is changed along at least one degree of freedom by the force applied by the user, where the force applied must reach some minimum threshold value in order for the contacted portion to change positions and to effect the haptic feedback. Achievement or registration of the change in position of the contacted portion results in a responsive force (e.g., spring-back, vibration, pulsing) which is also imposed on the contacted portion of the device acted upon by the user, which force is communicated to the user through his or her sense of touch.

[0010] One common example of a user interface device that employs a spring-back or “bi-phase” type of haptic feedback is a button on a mouse. The button does not move until the applied force reaches a certain threshold, at which point the button moves downward with relative ease and then stops – the collective sensation of which is defined as “clicking” the button. The user-applied force is substantially along an axis perpendicular to the button surface, as is the responsive (but opposite) force felt by the user.

[0011] In another example, when a user enters input on a touch screen the, screen confirms the input typically by a graphical change on the screen along with/without an auditory cue. A touch screen provides graphical feedback by way of visual cues on the screen such as color or shape changes. A touch pad provides visual feedback by means of a cursor on the screen. While above cues do provide feedback, the most intuitive and effective feedback from a finger actuated input device is a tactile one such as the detent of a keyboard key or the detent of a mouse wheel. Accordingly, incorporating haptic feedback on touch screens is desirable.

[0012] Haptic feedback capabilities are known to improve user productivity and efficiency, particularly in the context of data entry. It is believed by the inventors hereof that further improvements to the character and quality of the haptic sensation communicated to a user may further increase such productivity and efficiency. It would be additionally beneficial if such improvements were provided by a sensory feedback mechanism which is easy and cost-effective to manufacture, and does not add to, and preferably reduces, the space, size and/or mass requirements of known haptic feedback devices.

SUMMARY OF THE INVENTION

- [0013] The present invention includes devices, systems and methods involving electroactive transducers for sensory applications. In one variation, a user interface device having sensory feedback is provided. One benefit of the present invention is to provide the user of a user interface device with haptic feedback whenever an input is triggered by software or another signal generated by the device or associated components.
- [0014] In one example, the actuators can be driven by an audio signal that is separately generated by the device. Accordingly, the disclosure includes a method of producing a haptic effect in a user interface device simultaneously with a sound generated by a separately generated audio signal. One variation of this method includes routing the audio signal to a filtering circuit; altering the audio signal to produce a haptic drive signal by filtering a range of frequencies below a predetermined frequency; and providing the haptic drive signal to a power supply coupled to an electroactive polymer transducer such that the power supply actuates the electroactive polymer transducer to drive the haptic effect simultaneously to the sound generated by the audio signal.
- [0015] The method can include driving the electroactive polymer transducer to generate a sound effect using the filtered signal. Typically the predetermined frequency comprises an optimal frequency of the electroactive polymer actuator. For some EPAM devices this predetermined frequency comprises 200 hertz.
- [0016] In another variation, the method includes filtering the positive portion of an audio waveform of the audio signal to produce the haptic signal for a single phase actuator. In another variation, the method includes using a two phase electroactive polymer actuator and where altering the audio signal comprises filtering a positive portion of an audio waveform of the audio signal to drive a first phase of the electroactive polymer transducer, and inverting a negative portion of the audio waveform of the audio signal to drive a second phase of the electro active polymer transducer to improve performance of the electro active polymer transducer.
- [0017] The following disclosure also includes transducers comprising an electroactive polymer film comprising a dielectric elastomer layer, wherein a portion of the dielectric elastomer layer is stretched between first and second electrodes wherein at least one overlapping portion of the electrodes defines an active film region with at least one remaining portion of film defining an inactive film region; a first conductive layer disposed on at least a portion of the inactive film region and electrically coupled to the first electrode, and a second conductive layer disposed on at least a portion of the inactive film region and electrically coupled to the second electrode; and at least one passive incompressible polymer layer, the incompressible polymer layer extending over at least a

portion of one side of the electroactive polymer film, wherein activation of the active region changes a thickness dimension of the incompressible passive polymer layer.

[0018] The transducer can optionally comprise a first and a second passive incompressible polymer layers, where the first and second passive incompressible polymer layers are located on each side of the electroactive polymer film.

[0019] In another variation, transducer assembly can include at least two stacked layers of electroactive polymer film, each electroactive polymer film comprising a thin dielectric elastomer layer, wherein a portion of the dielectric elastomer layer is sandwiched between first and second electrodes wherein the overlapping portions of the electrodes define an active film region with the remaining portion of film defining an inactive film region, wherein the active film regions of the respective layers of electroactive polymer film are in stacked alignment and the inactive active film regions of the respective layers of electroactive polymer film are in stacked alignment; a first conductive layer disposed on at least a portion of the inactive film region of each electroactive polymer film and electrically coupled to the first electrode thereof, and a second conductive layer disposed on at least a portion of the inactive film region of each electroactive polymer film and electrically coupled to the second electrode thereof; and a passive incompressible polymer layer over each exposed side of the electroactive polymer films, wherein activation of the active regions changes a thickness dimension of the passive incompressible polymer layer.

[0020] The following disclosure also includes inertial electroactive polymer transducer. In one variation, an inertial electroactive polymer transducer includes an electroactive polymer film stretched between a top and bottom frame components, where a central portion of frame is open to expose a central surface of the electroactive polymer film; a first output member on the central surface of the electroactive polymer film; and at least one inertial mass affixed to the output disk wherein upon application of voltage difference across a first and second electrodes on the electroactive polymer film causes displacement of the polymer film causing the inertial mass to move.

[0021] Additional variations of an inertial electroactive polymer transducer include a second electroactive polymer film sandwiched between a top and bottom second frame components, where a central portion of second frame is open to expose a second central surface of the electroactive polymer film; and a second output member on the central surface of the electroactive polymer film, where the inertial mass is located between the affixed between the first and second output members.

[0022] The present devices and systems provide greater versatility as they can be employed within many types of input devices and provide feedback from multiple input elements. The system is also advantageous, as it does not add substantially to the

mechanical complexity of the device or to the mass and weight of the device. The system also accomplishes its function without any mechanical sliding or rotating elements thereby making the system durable, simple to assemble and easily manufacturable.

[0023] The present invention may be employed in any type of user interface device including, but not limited to, touch pads, touch screens or key pads or the like for computer, phone, PDA, video game console, GPS system, kiosk applications, etc.

[0024] As for other details of the present invention, materials and alternate related configurations may be employed as within the level of those with skill in the relevant art. The same may hold true with respect to method-based aspects of the invention in terms of additional acts as commonly or logically employed. In addition, though the invention has been described in reference to several examples, optionally incorporating various features, the invention is not to be limited to that which is described or indicated as contemplated with respect to each variation of the invention. Various changes may be made to the invention described and equivalents (whether recited herein or not included for the sake of some brevity) may be substituted without departing from the true spirit and scope of the invention. Any number of the individual parts or subassemblies shown may be integrated in their design. Such changes or others may be undertaken or guided by the principles of design for assembly.

[0025] These and other features, objects and advantages of the invention will become apparent to those persons skilled in the art upon reading the details of the invention as more fully described below.

BRIEF DESCRIPTION OF THE DRAWINGS

[0026] The invention is best understood from the following detailed description when read in conjunction with the accompanying schematic drawings. To facilitate understanding, the same reference numerals have been used (where practical) to designate similar elements that are common to the drawings. Included in the drawings are the following:

[0027] Figs. 1A and 1B illustrate some examples of a user interface that can employ haptic feedback when an EAP transducer is coupled to a display screen or sensor and a body of the device.

[0028] Figs. 2A and 2B, show a sectional view of a user interface device including a display screen having a surface that reacts with haptic feedback to a user's input.

[0029] Figs. 3A and 3B illustrate a sectional view of another variation of a user interface device having a display screen covered by a flexible membrane with active EAP formed into active gaskets.

[0030] Fig. 4 illustrates a sectional view of an additional variation of a user interface device having a spring biased EAP membrane located about an edge of the display screen.

- [0031] Fig. 5 shows a sectional view of a user interface device where the display screen is coupled to a frame using a number of compliant gaskets and the driving force for the display is a number of EAP actuators diaphragms.
- [0032] Figs. 6A and 6B show sectional views of a user interface 230 having a corrugated EAP membrane or film coupled between a display.
- [0033] Figs. 7A and 7B illustrate a top perspective view of a transducer before and after application of a voltage in accordance with one embodiment of the present invention.
- [0034] Figs. 8A and 8B show exploded top and bottom perspective views, respectively, of a sensory feedback device for use in a user interface device.
- [0035] Fig. 9A is a top planar view of an assembled electroactive polymer actuator of the present invention; Figs. 9B and 9C are top and bottom planar views, respectively, of the film portion of the actuator of Fig. 8A and, in particular, illustrate the two-phase configuration of the actuator.
- [0036] Figs. 9D and 9E illustrate an example of arrays of electro active polymer transducer for placing across a surface of a display screen that is spaced from a frame of the device.
- [0037] Figs. 9F and 9G are an exploded view and assembled view, respectively, of an array of actuators for use in a user interface device as disclosed herein.
- [0038] Fig. 10 illustrates a side view of the user interface devices with a human finger in operative contact with the contact surface of the device.
- [0039] Figs. 11A and 11B graphically illustrate the force-stroke relationship and voltage response curves, respectively, of the actuator of Figs. 9A-9C when operated in a single-phase mode.
- [0040] Figs. 12A and 12B graphically illustrate the force-stroke relationship and voltage response curves, respectively, of the actuator of Figs. 9A-9C when operated in a two-phase mode.
- [0041] Fig. 13 is a block diagram of electronic circuitry, including a power supply and control electronics, for operating the sensory feedback device.
- [0042] Figs. 14A and 14B shows a partial cross sectional view of an example of a planar array of EAP actuators coupled to a user input device.
- [0043] Figs. 15A and 15B schematically illustrate a surface deformation EAP transducer employed as an actuator which utilizes polymer surface features to provide work output when the transducer is activated;
- [0044] Figs. 16A and 16B are cross-sectional views of exemplary constructs of an actuator of the present invention;

- [0045] Figs. 17A-17D illustrate various steps of a process for making electrical connections within the subject transducers for coupling to a printed circuit board (PCB) or flex connector;
- [0046] Figs. 18A-18D illustrate various steps of a process for making electrical connections within the subject transducers for coupling to an electrical wire;
- [0047] Fig. 19 is a cross-sectional view of a subject transducer having a piercing type of electrical contact;
- [0048] Figs. 20A and 20B are top views of a thickness mode transducer and electrode pattern, respectively, for application in a button-type actuator;
- [0049] Fig. 21 illustrates a top cutaway view of a keypad employing an array of button-type actuators of Figs. 6A and 6B;
- [0050] Fig. 22 illustrates a top view of a thickness mode transducer for use in a novelty actuator in the form of a human hand;
- [0051] Fig. 23 illustrates a top view of thickness mode transducer in a continuous strip configuration;
- [0052] Fig. 24 illustrates a top view of a thickness mode transducer for application in a gasket-type actuator;
- [0053] Figs. 25A-25D are cross-sectional views of touch screens employing various type gasket-type actuators;
- [0054] Figs. 26A and 26B are cross-sectional views of another embodiment of a thickness mode transducer of the present invention in which the relative positions of the active and passive areas of the transducer are inversed from the above embodiments.
- [0055] Figs. 27A-27D illustrate an example of an electroactive inertial transducer.
- [0056] Fig. 28A illustrates one example of a circuit to tune an audio signal to work within optimal haptic frequencies for electroactive polymer actuators.
- [0057] Fig. 28B illustrates an example of a modified haptic signal filtered by the circuit of Fig. 28A.
- [0058] Figs. 28C and 28F illustrate additional circuits for producing signals for single and double phase electroactive transducers.
- [0059] Figs. 28E and 28F show an example of a device having one or more electroactive polymer actuators within the device body and coupled to an inertial mass.
- [0060] Variation of the invention from that shown in the figures is contemplated.

DETAILED DESCRIPTION OF THE INVENTION

- [0061] The devices, systems and methods of the present invention are now described in detail with reference to the accompanying figures.
- [0062] As noted above, devices requiring a user interface can be improved by the use of haptic feedback on the user screen of the device. Figs 1A and 1B illustrate simple examples of such devices **190**. Each device includes a display screen **232** for which the user enters or views data. The display screen is coupled to a body or frame **234** of the device. Clearly, any number of devices are included within the scope of this disclosure regardless of whether portable (e.g., cell phones, computers, manufacturing equipment, etc.) or affixed to other non-portable structures (e.g., the screen of an information display panel, automatic teller screens, etc.) For purposes of this disclosure, a display screen can also include a touchpad type device where user input or interaction takes place on a monitor or location away from the actual touchpad (e.g., a lap-top computer touchpad).
- [0063] A number of design considerations favor the selection and use of advanced dielectric elastomer materials, also referred to as “electroactive polymers” (EAPs), for the fabrication of transducers especially when haptic feedback of the display screen **232** is sought. These considerations include potential force, power density, power conversion/consumption, size, weight, cost, response time, duty cycle, service requirements, environmental impact, etc. As such, in many applications, EAP technology offers an ideal replacement for piezoelectric, shape-memory alloy (SMA) and electromagnetic devices such as motors and solenoids.
- [0064] An EAP transducer comprises two thin film electrodes having elastic characteristics and separated by a thin elastomeric dielectric material. When a voltage difference is applied to the electrodes, the oppositely-charged electrodes attract each other thereby compressing the polymer dielectric layer therebetween. As the electrodes are pulled closer together, the dielectric polymer film becomes thinner (the z-axis component contracts) as it expands in the planar directions (the x- and y-axis components expand).
- [0065] Figs. 2A-2B, shows a portion of a user interface device **230** with a display screen **232** having a surface that is physically touched by the user in response to information, controls, or stimuli on the display screen. The display screen **234** can be any type of a touch pad or screen panel such as a liquid crystal display (LCD), organic light emitting diode (OLED) or the like. In addition, variations of interface devices **230** can include display screens **232** such as a “dummy” screen, where an image transposed on the screen (e.g., projector or graphical covering), the screen can include conventional monitors or even a screen with fixed information such as common signs or displays.

[0066] In any case, the display screen 232 includes a frame 234 (or housing or any other structure that mechanically connects the screen to the device via a direct connection or one or more ground elements), and an electroactive polymer (EAP) transducer 236 that couples the screen 232 to the frame or housing 234. As noted herein, the EAP transducers can be along an edge of the screen 232 or an array of EAP transducers can be placed in contact with portion of the screen 232 that are spaced away from the frame or housing 234.

[0067] Figs. 2A and 2B illustrate a basic user interface device where an encapsulated EAP transducer 236 forms an active gasket. Any number of active gasket EAPs 236 can be coupled between the touch screen 232 and frame 234. Typically, enough active gasket EAPs 236 are provided to produce the desired haptic sensation. However, the number will often vary depending on the particular application. In a variation of the device, the touch screen 232 may either comprise a display screen or a sensor plate (where the display screen would be behind the sensor plate).

[0068] The figures show the user interface device 230 cycling the touch screen 232 between an inactive and active state. Fig. 2A shows the user interface device 230 where the touch screen 232 is in an inactive state. In such a condition, no field is applied to the EAP transducers 236 allowing the transducers to be at a resting state. Fig. 2B shows the user interface device 230 after some user input triggers the EAP transducer 236 into an active state where the transducers 236 cause the display screen 232 to move in the direction shown by arrows 238. Alternatively, the displacement of one or more EAP transducers 236 can vary to produce a directional movement of the display screen 232 (e.g., rather than the entire display screen 232 moving uniformly one area of the screen 232 can displace to a larger degree than another area). Clearly, a control system coupled to the user interface device 230 can be configured to cycle the EAPS 236 with a desired frequency and/or to vary the amount of deflection of the EAP 236.

[0069] Figs. 3A and 3B illustrate another variation of a user interface device 230 having a display screen 232 covered by a flexible membrane 240 that functions to protect the display screen 232. Again, the device can include a number of active gasket EAPs 236 coupling the display screen 232 to a base or frame 234. In response to a user input, the screen 232 along with the membrane 240 displaces when an electric field is applied to the EAPs 236 causing displacement so that the device 230 enters an active state.

[0070] Fig. 4 illustrates an additional variation of a user interface device 230 having a spring biased EAP membrane 244 located about an edge of the display screen 232. The EAP membrane 244 can be placed about a perimeter of the screen or only in those locations that permit the screen to produce haptic feedback to the user. In this variation, a passive compliant gasket or spring 244 provides a force against the screen 232 thereby placing the

EAP membranes 242 in a state of tension. Upon providing an electric field 242 to the membrane (again, upon a signal generated by a user input), the EAP membranes 242 relax to cause displacement of the screen 232. As noted by arrows 246, the user input device 230 can be configured to produce movement of the screen 232 in any direction relative to the bias provided by the gasket 244. In addition, actuation of less than all the EAP membranes 242 produces non-uniform movement of the screen 232.

[0071] Fig. 5 illustrates yet another variation of a user interface device 230. In this example, the display screen 232 is coupled to a frame 234 using a number of compliant gaskets 244 and the driving force for the display 232 is a number of EAP actuators diaphragms 248. The EAP actuator diaphragms 248 are spring biased and upon application of an electric field can drive the display screen. As shown, the EAP actuator diaphragms 248 have opposing EAP membranes on either side of a spring. In such a configuration, activating opposite sides of the EAP actuator diaphragms 248 makes the assembly rigid at a neutral point. The EAP actuator diaphragms 248 act like the opposing bicep and triceps muscles that control movements of the human arm. Though not shown, as discussed in U.S. Patent Application Serial Nos. 11/085,798 and 11/085,804 the actuator diaphragms 248 can be stacked to provide two-phase output action and/or to amplify the output for use in more robust applications.

[0072] Figs. 6A and 6B show another variation of a user interface 230 having an EAP membrane or film 242 coupled between a display 232 and a frame 234 at a number of points or ground elements 252 to accommodate corrugations or folds in the EAP film 242. As shown in Fig. 6B, the application of an electric field to the EAP film 242 causes displacement in the direction of the corrugations and deflects the display screen 232 relative to the frame 234. The user interface 232 can optionally include bias springs 250 also coupled between the display 232 and the frame 234 and/or a flexible protective membrane 240 covering a portion (or all) of the display screen 232.

[0073] It is noted that the figures discussed above schematically illustrate exemplary configurations of such tactile feedback devices that employ EAP films or transducers. Many variations are within the scope of this disclosure, for example, in variations of the device, the EAP transducers can be implemented to move only a sensor plate or element (e.g., one that is triggered upon user input and provides a signal to the EAP transducer) rather than the entire screen or pad assembly.

[0074] In any application, the feedback displacement of a display screen or sensor plate by the EAP member can be exclusively in-plane which is sensed as lateral movement, or can be out-of-plane (which is sensed as vertical displacement). Alternatively, the EAP transducer material may be segmented to provide independently addressable/movable sections so as to provide angular

displacement of the plate element. In addition, any number of EAP transducers or films (as disclosed in the applications and patent listed above) can be incorporated in the user interface devices described herein.

[0075] The variations of the devices described herein allows the entire sensor plate (or display screen) of the device to act as a tactile feedback element. This allows for extensive versatility. For example, the screen can bounce once in response to a virtual key stroke or, it can output consecutive bounces in response to a scrolling element such as a slide bar on the screen, effectively simulating the mechanical detents of a scroll wheel. With the use of a control system, a three-dimensional outline can be synthesized by reading the exact position of the user's finger on the screen and moving the screen panel accordingly to simulate the 3D structure. Given enough screen displacement, and significant mass of the screen, the repeated oscillation of the screen may even replace the vibration function of a mobile phone. Such functionality may be applied to browsing of text where a scrolling (vertically) of one line of text is represented by a tactile "bump", thereby simulating detents. In the context of video gaming, the present invention provides increased interactivity and finer motion control over oscillating vibratory motors employed in prior art video game systems. In the case of a touchpad, user interactivity and accessibility may be improved, especially for the visually impaired, by providing physical cues.

[0076] The EAP transducer may be configured to displace proportionally to an applied voltage, which facilitates programming of a control system used with the subject tactile feedback devices. For example, a software algorithm may convert pixel grayscale to EAP transducer displacement, whereby the pixel grayscale value under the tip of the screen cursor is continuously measured and translated into a proportional displacement by the EAP transducer. By moving a finger across the touchpad, one could feel or sense a rough 3D texture. A similar algorithm may be applied on a web page, where the border of an icon is fed back to the user as a bump in the page texture or a buzzing button upon moving a finger over the icon. To a normal user, this would provide an entirely new sensory experience while surfing the web, to the visually impaired this would add indispensable feedback.

[0077] EAP transducers are ideal for such applications for a number of reasons. For example, because of their light weight and minimal components, EAP transducers offer a very low profile and, as such, are ideal for use in sensory/haptic feedback applications. .

[0078] Figs. 7A and 7B illustrate an example of an EAP film or membrane 10 structure. A thin elastomeric dielectric film or layer 12 is sandwiched between compliant or stretchable electrode plates or layers 14 and 16, thereby forming a capacitive structure or film. The length "l" and width "w" of the dielectric layer, as well as that of the composite structure, are much greater than its thickness "t". Typically, the dielectric layer has a thickness in range from about 10 μm to about 100 μm , with the total thickness of the structure in the

range from about 25 μm to about 10 cm. Additionally, it is desirable to select the elastic modulus, thickness, and/or the microgeometry of electrodes 14, 16 such that the additional stiffness they contribute to the actuator is generally less than the stiffness of the dielectric layer 12, which has a relatively low modulus of elasticity, i.e., less than about 100 MPa and more typically less than about 10 MPa, but is likely thicker than each of the electrodes. Electrodes suitable for use with these compliant capacitive structures are those capable of withstanding cyclic strains greater than about 1% without failure due to mechanical fatigue.

[0079] As seen in Fig. 7B, when a voltage is applied across the electrodes, the unlike charges in the two electrodes 14, 16 are attracted to each other and these electrostatic attractive forces compress the dielectric film 12 (along the Z-axis). The dielectric film 12 is thereby caused to deflect with a change in electric field. As electrodes 14, 16 are compliant, they change shape with dielectric layer 12. Generally speaking, deflection refers to any displacement, expansion, contraction, torsion, linear or area strain, or any other deformation of a portion of dielectric film 12. Depending on the form fit architecture, e.g., a frame, in which capacitive structure 10 is employed (collectively referred to as a "transducer"), this deflection may be used to produce mechanical work. Various different transducer architectures are disclosed and described in the above-identified patent references.

[0080] With a voltage applied, the transducer film 10 continues to deflect until mechanical forces balance the electrostatic forces driving the deflection. The mechanical forces include elastic restoring forces of the dielectric layer 12, the compliance or stretching of the electrodes 14, 16 and any external resistance provided by a device and/or load coupled to transducer 10. The resultant deflection of the transducer 10 as a result of the applied voltage may also depend on a number of other factors such as the dielectric constant of the elastomeric material and its size and stiffness. Removal of the voltage difference and the induced charge causes the reverse effects.

[0081] In some cases, the electrodes 14 and 16 may cover a limited portion of dielectric film 12 relative to the total area of the film. This may be done to prevent electrical breakdown around the edge of the dielectric or achieve customized deflections in certain portions thereof. Dielectric material outside an active area (the latter being a portion of the dielectric material having sufficient electrostatic force to enable deflection of that portion) may be caused to act as an external spring force on the active area during deflection. More specifically, material outside the active area may resist or enhance active area deflection by its contraction or expansion.

[0082] The dielectric film 12 may be pre-strained. The pre-strain improves conversion between electrical and mechanical energy, i.e., the pre-strain allows the dielectric film 12 to

deflect more and provide greater mechanical work. Pre-strain of a film may be described as the change in dimension in a direction after pre-straining relative to the dimension in that direction before pre-straining. The pre-strain may comprise elastic deformation of the dielectric film and be formed, for example, by stretching the film in tension and fixing one or more of the edges while stretched. The pre-strain may be imposed at the boundaries of the film or for only a portion of the film and may be implemented by using a rigid frame or by stiffening a portion of the film.

[0083] The transducer structure of Figs. 7A and 7B and other similar compliant structures and the details of their constructs are more fully described in many of the referenced patents and publications disclosed herein.

[0084] In addition to the EAP films described above, sensory or haptic feedback user interface devices can include EAP transducers designed to produce lateral movement. For example, various components including, from top to bottom as illustrated in Figs. 8A and 8B, actuator **30** having an electroactive polymer (EAP) transducer **10** in the form of an elastic film which converts electrical energy to mechanical energy (as noted above). The resulting mechanical energy is in the form of physical "displacement" of an output member, here in the form of a disc **28**.

[0085] With reference to Figs. 9A-9C, EAP transducer film **10** comprises two working pairs of thin elastic electrodes **32a**, **32b** and **34a**, **34b** where each working pair is separated by a thin layer of elastomeric dielectric polymer **26** (e.g., made of acrylate, silicone, urethane, thermoplastic elastomer, hydrocarbon rubber, fluorelastomer, or the like). When a voltage difference is applied across the oppositely-charged electrodes of each working pair (i.e., across electrodes **32a** and **32b**, and across electrodes **34a** and **34b**), the opposed electrodes attract each other thereby compressing the dielectric polymer layer **26** therebetween. As the electrodes are pulled closer together, the dielectric polymer **26** becomes thinner (i.e., the z-axis component contracts) as it expands in the planar directions (i.e., the x- and y-axes components expand) (see Figs. 9B and 9C for axis references). Furthermore, like charges distributed across each electrode cause the conductive particles embedded within that electrode to repel one another, thereby contributing to the expansion of the elastic electrodes and dielectric films. The dielectric layer **26** is thereby caused to deflect with a change in electric field. As the electrode material is also compliant, the electrode layers change shape along with dielectric layer **26**. Generally speaking, deflection refers to any displacement, expansion, contraction, torsion, linear or area strain, or any other deformation of a portion of dielectric layer **26**. This deflection may be used to produce mechanical work.

[0086] In fabricating transducer **20**, elastic film is stretched and held in a pre-strained condition by two opposing rigid frame sides **8a**, **8b**. It has been observed that the pre-strain improves the dielectric strength of the polymer layer **26**, thereby improving conversion between electrical and mechanical energy, i.e., the pre-strain allows the film to deflect more and provide greater mechanical work. Typically, the electrode material is applied after pre-straining the polymer layer, but may be applied beforehand. The two electrodes provided on the same side of layer **26**, referred to herein as same-side electrode pairs, i.e., electrodes **32a** and **34a** on top side **26a** of dielectric layer **26** (see Fig. 9B) and electrodes **32b** and **34b** on bottom side **26b** of dielectric layer **26** (see Fig. 9C), are electrically isolated from each other by inactive areas or gaps **25**. The opposed electrodes on the opposite sides of the polymer layer from two sets of working electrode pairs, i.e., electrodes **32a** and **32b** for one working electrode pair and electrodes **34a** and **34b** for another working electrode pair. Each same-side electrode pair preferably has the same polarity, while the polarity of the electrodes of each working electrode pair are opposite each other, i.e., electrodes **32a** and **32b** are oppositely charged and electrodes **34a** and **34b** are oppositely charged. Each electrode has an electrical contact portion **35** configured for electrical connection to a voltage source (not shown).

[0087] In the illustrated embodiment, each of the electrodes has a semi-circular configuration where the same-side electrode pairs define a substantially circular pattern for accommodating a centrally disposed, rigid output disc **20a**, **20b** on each side of dielectric layer **26**. Discs **20a**, **20b**, the functions of which are discussed below, are secured to the centrally exposed outer surfaces **26a**, **26b** of polymer layer **26**, thereby sandwiching layer **26** therebetween. The coupling between the discs and film may be mechanical or be provided by an adhesive bond. Generally, the discs **20a**, **20b** will be sized relative to the transducer frame **22a**, **22b**. More specifically, the ratio of the disc diameter to the inner annular diameter of the frame will be such so as to adequately distribute stress applied to transducer film **10**. The greater the ratio of the disc diameter to the frame diameter, the greater the force of the feedback signal or movement but with a lower linear displacement of the disc. Alternately, the lower the ratio, the lower the output force and the greater the linear displacement.

[0088] Depending upon the electrode configurations, transducer **10** can be capable of functioning in either a single or a two-phase mode. In the manner configured, the mechanical displacement of the output component, i.e., the two coupled discs **20a** and **20b**, of the subject sensory feedback device described above is lateral rather than vertical. In other words, instead of the sensory feedback signal being a force in a direction perpendicular to the display surface **232** of the user interface and parallel to the input force

(designated by arrow **60a** in Fig. 10) applied by the user's finger **38** (but in the opposing or upward direction), the sensed feedback or output force (designated by double-head arrow **60b** in Fig. 10) of the sensory/haptic feedback devices of the present invention is in a direction parallel to the display surface **232** and perpendicular to input force **60a**.

Depending on the rotational alignment of the electrode pairs about an axis perpendicular to the plane of transducer **10** and relative to the position of the display surface **232** mode in which the transducer is operated (i.e., single phase or two phase), this lateral movement may be in any direction or directions within 360°. For example, the lateral feedback motion may be from side to side or up and down (both are two-phase actuations) relative to the forward direction of the user's finger (or palm or grip, etc.). While those skilled in the art will recognize certain other actuator configurations which provide a feedback displacement which is transverse or perpendicular to the contact surface of the haptic feedback device, the overall profile of a device so configured may be greater than the aforementioned design.

[0089] Figs. 9D-9G illustrate an example of an array of electro-active polymers that can be placed across the display screen of the device. In this example, voltage and ground sides **200a** and **200b**, respectively, of an EAP film array **200** (see Fig. 9F) for use in an array of EAP actuators for use in the tactile feedback devices of the present invention. Film array **200** includes an electrode array provided in a matrix configuration to increase space and power efficiency and simplify control circuitry. The high voltage side **200a** of the EAP film array provides electrode patterns **202** running in vertically (according to the view point illustrated in Fig. 9D) on dielectric film **208** materials. Each pattern **202** includes a pair of high voltage lines **202a**, **202b**. The opposite or ground side **200b** of the EAP film array provides electrode patterns **206** running transversally relative to the high voltage electrodes, i.e., horizontally. Each pattern **206** includes a pair of ground lines **206a**, **206b**. Each pair of opposing high voltage and ground lines (**202a**, **206a** and **202b**, **206b**) provides a separately activatable electrode pair such that activation of the opposing electrode pairs provides a two-phase output motion in the directions illustrated by arrows **212**. The assembled EAP film array **200** (illustrating the intersecting pattern of electrodes on top and bottom sides of dielectric film **208**) is provided in Fig. 9F within an exploded view of an array **204** of EAP transducers **222**, the latter of which is illustrated in its assembled form in Fig. 9G. EAP film array **200** is sandwiched between opposing frame arrays **214a**, **214b**, with each individual frame segment **216** within each of the two arrays defined by a centrally positioned output disc **218** within an open area. Each combination of frame/disc segments **216** and electrode configurations form an EAP transducer **222**. Depending on the application and type of actuator desired, additional layers of components may be added to transducer array **204**. The transducer array **220** may be

incorporated in whole to a user interface array, such as a display screen, sensor surface, or touch pad, for example.

[0090] When operating sensory/haptic feedback device **2** in single-phase mode, only one working pair of electrodes of actuator **30** would be activated at any one time. The single-phase operation of actuator **30** may be controlled using a single high voltage power supply. As the voltage applied to the single-selected working electrode pair is increased, the activated portion (one half) of the transducer film will expand, thereby moving the output disc **20** in-plane in the direction of the inactive portion of the transducer film. Fig. 11A illustrates the force-stroke relationship of the sensory feedback signal (i.e., output disc displacement) of actuator **30** relative to neutral position when alternately activating the two working electrode pairs in single-phase mode. As illustrated, the respective forces and displacements of the output disc are equal to each other but in opposite directions. Fig. 11B illustrates the resulting non-linear relationship of the applied voltage to the output displacement of the actuator when operated in this single-phase mode. The “mechanical” coupling of the two electrode pairs by way of the shared dielectric film may be such as to move the output disc in opposite directions. Thus, when both electrode pairs are operated, albeit independently of each other, application of a voltage to the first working electrode pair (phase 1) will move the output disc **20** in one direction, and application of a voltage to the second working electrode pair (phase 2) will move the output disc **20** in the opposite direction. As the various plots of Fig. 11B reflect, as the voltage is varied linearly, the displacement of the actuator is non-linear. The acceleration of the output disk during displacement can also be controlled through the synchronized operation of the two phases to enhance the haptic feedback effect. The actuator can also be partitioned into more than two phases that can be independently activated to enable more complex motion of the output disk.

[0091] To effect a greater displacement of the output member or component, and thus provide a greater sensory feedback signal to the user, actuator **30** is operated in a two-phase mode, i.e., activating both portions of the actuator simultaneously. Fig. 12A illustrates the force-stroke relationship of the sensory feedback signal of the output disc when the actuator is operated in two-phase mode. As illustrated, both the force and stroke of the two portions **32, 34** of the actuator in this mode are in the same direction and have double the magnitude than the force and stroke of the actuator when operated in single-phase mode. Fig. 12B illustrates the resulting linear relationship of the applied voltage to the output displacement of the actuator when operated in this two-phase mode. By connecting the mechanically coupled portions **32, 34** of the actuator electrically in series and controlling their common node **55**, such as in the manner illustrated in the block diagram **40** of Fig. 13, the relationship between the voltage of the common node **55** and the displacement (or blocked

force) of the output member (in whatever configuration) approach a linear correlation. In this mode of operation, the non-linear voltage responses of the two portions **32**, **34** of actuator **30** effectively cancel each other out to produce a linear voltage response. With the use of control circuitry **44** and switching assemblies **46a**, **46b**, one for each portion of the actuator, this linear relationship allows the performance of the actuator to be fine-tuned and modulated by the use of varying types of waveforms supplied to the switch assemblies by the control circuitry. Another advantage of using circuit **40** is the ability to reduce the number of switching circuits and power supplies needed to operate the sensory feedback device. Without the use of circuit **40**, two independent power supplies and four switching assemblies would be required. Thus, the complexity and cost of the circuitry are reduced while the relationship between the control voltage and the actuator displacement are improved, i.e., made more linear.

[0092] Various types of mechanisms may be employed to communicate the input force **60a** from the user to effect the desired sensory feedback **60b** (see Fig. 10). For example, a capacitive or resistive sensor **50** (see Fig. 13) may be housed within the user interface pad **4** to sense the mechanical force exerted on the user contact surface input by the user. The electrical output **52** from sensor **50** is supplied to the control circuitry **44** that in turn triggers the switch assemblies **46a**, **46b** to apply the voltage from power supply **42** to the respective transducer portions **32**, **34** of the sensory feedback device in accordance with the mode and waveform provided by the control circuitry.

[0093] Another variation of the present invention involves the hermetic sealing of the EAP actuators to minimize any effects of humidity or moisture condensation that may occur on the EAP film. For the various embodiments described below, the EAP actuator is sealed in a barrier film substantially separately from the other components of the tactile feedback device. The barrier film or casing may be made of, such as foil, which is preferably heat sealed or the like to minimize the leakage of moisture to within the sealed film. Portions of the barrier film or casing can be made of a compliant material to allow improved mechanical coupling of the actuator inside the casing to a point external to the casing. Each of these device embodiments enables coupling of the feedback motion of the actuator's output member to the contact surface of the user input surface, e.g., keypad, while minimizing any compromise in the hermetically sealed actuator package. Various exemplary means for coupling the motion of the actuator to the user interface contact surface are also provided. Regarding methodology, the subject methods may include each of the mechanical and/or activities associated with use of the devices described. As such, methodology implicit to the use of the devices described forms part of the invention. Other methods may focus on fabrication of such devices.

[0094] Fig. 14A shows an example of a planar array of EAP actuators **204** coupled to a user input device **190**. As show, the array of EAP actuators **204** covers a portion of the screen **232** and is coupled to a frame **234** of the device **190** via a stand off **256**. In this variation, the stand off **256** permits clearance for movement of the actuators **204** and screen **232**. In one variation of the device **190** the array of actuators **204** can be multiple discrete actuators or an array of actuators behind the user interface surface or screen **232** depending upon the desired application. Fig. 14B shows a bottom view of the device **190** of Fig. 14A. As shown by arrow **254** the EAP actuators **204** can allow for movement of the screen **232** along an axis either as an alternative to, or in combination with movement in a direction normal to the screen **232**.

[0095] The transducer/actuator embodiments described thus far have the passive layer(s) coupled to both the active (i.e., areas including overlapping electrodes) and inactive regions of the EAP transducer film. Where the transducer/actuator has also employed a rigid output structure, that structure has been positioned over areas of the passive layers that reside above the active regions. Further, the active/activatable regions of these embodiments have been positioned centrally relative to the inactive regions. The present invention also includes other transducer/actuator configurations. For example, the passive layer(s) may cover only the active regions or only the inactive regions. Additionally, the inactive regions of the EAP film may be positioned centrally to the active regions.

[0096] Referring to Figs. 15A and 15B, a schematic representation is provided of a surface deformation EAP actuator **10** for converting electrical energy to mechanical energy in accordance with one embodiment of the invention. Actuator **10** includes EAP transducer **12** having a thin elastomeric dielectric polymer layer **14** and top and bottom electrodes **16a**, **16b** attached to the dielectric **14** on portions of its top and bottom surfaces, respectively. The portion of transducer **12** comprising the dielectric and at least two electrodes is referred to herein as an active area. Any of the transducers of the present invention may have one or more active areas.

[0097] When a voltage difference is applied across the oppositely-charged electrodes **16a**, **16b**, the opposed electrodes attract each other thereby compressing the portion of the dielectric polymer layer **14** therebetween. As the electrodes **16a**, **16b** are pulled closer together (along the z-axis), the portion of the dielectric layer **14** between them becomes thinner as it expands in the planar directions (along the x- and y-axes). For incompressible polymers, i.e., those having a substantially constant volume under stress, or for otherwise compressible polymers in a frame or the like, this action causes the compliant dielectric material outside the active area (i.e., the area covered by the electrodes), particularly perimetrically about, i.e., immediately around, the edges of the active area, to be displaced

or bulge out-of-plane in the thickness direction (orthogonal to the plane defined by the transducer film). This bulging produces dielectric surface features **24a-d**. While out-of-plane surface features **24** are shown relatively local to the active area, the out-of-plane is not always localized as shown. In some cases, if the polymer is pre-strained, then the surface features **24a-b** are distributed over a surface area of the inactive portion of the dielectric material.

[0098] In order to amplify the vertical profile and/or visibility of surface features of the subject transducers, an optional passive layer may be added to one or both sides of the transducer film structure where the passive layer covers all or a portion of the EAP film surface area. In the actuator embodiment of Figs. 15A and 15B, top and bottom passive layers **18a**, **18b** are attached to the top and bottom sides, respectively, of the EAP film **12**. Activation of the actuator and the resulting surface features **17a-d** of dielectric layer **12** are amplified by the added thickness of passive layers **18a**, **18b**, as denoted by reference numbers **26a-d** in Fig. 15B.

[0099] In addition to the elevated polymer/passive layer surface features **26a-d**, the EAP film **12** may be configured such that the one or both electrodes **16a**, **16b** are depressed below the thickness of the dielectric layer. As such, the depressed electrode or portion thereof provides an electrode surface feature upon actuation of the EAP film **12** and the resulting deflection of dielectric material **14**. Electrodes **16a**, **16c** may be patterned or designed to produce customized transducer film surface features which may comprise polymer surface features, electrode surface features and/or passive layer surface features.

[00100] In the actuator embodiment **10** of Figs. 15A and 15B, one or more structures **20a**, **20b** are provided to facilitate coupling the work between the compliant passive slab and a rigid mechanical structure and directing the work output of the actuator. Here, top structure **20a** (which may be in the form of a platform, bar, lever, rod, etc.) acts as an output member while bottom structure **20b** serves to couple actuator **10** to a fixed or rigid structure **22**, such as ground. These output structures need not be discrete components but, rather, may be integrated or monolithic with the structure which the actuator is intended to drive. Structures **20a**, **20b** also serve to define the perimeter or shape of the surface features **26a-d** formed by the passive layers **18a**, **18b**. In the illustrated embodiment, while the collective actuator stack produces an increase in thickness of the actuator's inactive portions, as shown in Fig. 15B, the net change in height Δh undergone by the actuator upon actuation is negative.

[00101] The EAP transducers of the present invention may have any suitable construct to provide the desired thickness mode actuation. For example, more than one EAP film layer may be used to fabricate the transducers for use in more complex applications, such as

keyboard keys with integrated sensing capabilities where an additional EAP film layer may be employed as a capacitive sensor.

[00102] Fig. 16A illustrates such an actuator 30 employing a stacked transducer 32 having a double EAP film layer 34 in accordance with the present invention. The double layer includes two dielectric elastomer films with the top film 34a sandwiched between top and bottom electrodes 34b, 34c, respectively, and the bottom film 36a sandwiched between top and bottom electrodes 36b, 36c, respectively. Pairs of conductive traces or layers (commonly referred to as “bus bars”) are provided to couple the electrodes to the high voltage and ground sides of a source of power (the latter not shown). The bus bars are positioned on the “inactive” portions of the respective EAP films (i.e., the portions in which the top and bottom electrodes do not overlap). Top and bottom bus bars 42a, 42b are positioned on the top and bottom sides, respectively, of dielectric layer 34a, and top and bottom bus bars 44a, 44b positioned on the top and bottom sides, respectively, of dielectric layer 36a. The top electrode 34b of dielectric 34a and the bottom electrode 36c of dielectric 36a, i.e., the two outwardly facing electrodes, are commonly polarized by way of the mutual coupling of bus bars 42a and 44a through conductive elastomer via 68a (shown in Fig. 16B), the formation of which is described in greater detail below with respect to Figs. 17A-17D. The bottom electrode 34c of dielectric 34a and the top electrode 36b of dielectric 36a, i.e., the two inwardly facing electrodes, are also commonly polarized by way of the mutual coupling of bus bars 42b and 44b through conductive elastomer via 68b (shown in Fig. 16B). Potting material 66a, 66b is used to seal via 68a, 68b. When operating the actuator, the opposing electrodes of each electrode pair are drawn together when a voltage is applied. For safety purposes, the ground electrodes may be placed on the outside of the stack so as to ground any piercing object before it reaches the high voltage electrodes, thus eliminating a shock hazard. The two EAP film layers may be adhered together by film-to-film adhesive 40b. The adhesive layer may optionally include a passive or slab layer to enhance performance. A top passive layer or slab 50a and a bottom passive layer 52b are adhered to the transducer structure by adhesive layer 40a and by adhesive layer 40c. Output bars 46a, 46b may be coupled to top and bottom passive layers, respectively, by adhesive layers 48a, 48b, respectfully.

[00103] The actuators of the present invention may employ any suitable number of transducer layers, where the number of layers may be even or odd. In the latter construct, one or more common ground electrode and bus bar may be used. Additionally, where safety is less of an issue, the high voltage electrodes may be positioned on the outside of the transducer stack to better accommodate a particular application.

[00104] To be operational, actuator 30 must be electrically coupled to a source of power and control electronics (neither are shown). This may be accomplished by way of electrical tracing or wires on the actuator or on a PCB or a flex connector 62 which couples the high voltage and ground vias 68a, 68b to a power supply or an intermediate connection. Actuator 30 may be packaged in a protective barrier material to seal it from humidity and environmental contaminants. Here, the protective barrier includes top and bottom covers 60, 64 which are preferably sealed about PCB/flex connector 62 to protect the actuator from external forces and strains and/or environmental exposure. In some embodiments, the protective barrier maybe impermeable to provide a hermetic seal. The covers may have a somewhat rigid form to shield actuator 30 against physical damage or may be compliant to allow room for actuation displacement of the actuator 30. In one specific embodiment, the top cover 60 is made of formed foil and the bottom cover 64 is made of a compliant foil, or vice versa, with the two covers then heat-sealed to board/connector 62. Many other packaging materials such as metalized polymer films, PVDC, Aclar, styrenic or olefinic copolymers, polyesters and polyolefins can also be used. Compliant material is used to cover the output structure or structures, here bar 46b, which translate actuator output.

[00105] The conductive components/layers of the stacked actuator/transducer structures of the present invention, such as actuator 30 just described, are commonly coupled by way of electrical vias (68a and 68b in Fig. 16B) formed through the stacked structure. Figs. 17a-19 illustrate various methods of the present invention for forming the vias.

[00106] Formation of the conductive vias of the type employed in actuator 30 of Fig. 16B is described with reference to Figs. 17A-17D. Either before or after lamination of actuator 70 (here, constructed from a single-film transducer with diametrically positioned bus bars 76a, 76b placed on opposite sides of the inactive portions of dielectric layer 74, collectively sandwiched between passive layers 78a, 78b) to a PCB/flex connector 72, the stacked transducer/actuator structure 70 is laser drilled 80 through its entire thickness to PCB 72 to form the via holes 82a, 82b, as illustrated in Fig. 17B. Other methods for creating the via holes can also be used such as mechanically drilling, punching, molding, piercing, and coring. The via holes are then filled by any suitable dispensing method, such as by injection, with a conductive material, e.g., carbon particles in silicone, as shown in Fig. 17C. Then, as shown in Fig. 17D, the conductively filled vias 84a, 84b are optionally potted 86a, 86b with any compatible non-conductive material, e.g., silicone, to electrically isolate the exposed end of the vias. Alternatively, a non-conductive tape may be placed over the exposed vias.

[00107] Standard electrical wiring may be used in lieu of a PCB or flex connector to couple the actuator to the power supply and electronics. Various steps of forming the electrical

vias and electrical connections to the power supply with such embodiments are illustrated in Figs. 18A-18D with like components and steps to those in Figs. 17A-17D having the same reference numbers. Here, as shown in Fig. 18A, via holes **82a**, **82b** need only be drilled to a depth within the actuator thickness to the extent that the bus bars **84a**, **84b** are reached. The via holes are then filled with conductive material, as shown in Fig. 18B, after which wire leads **88a**, **88b** are inserted into the deposited conductive material, as shown in Fig. 18C. The conductively filled vias and wire leads may then be potted over, as shown in Fig. 18D.

[00108] Fig. 19 illustrates another manner of providing conductive vias within the transducers of the present invention. Transducer **100** has a dielectric film comprising a dielectric layer **104** having portions sandwiched between electrodes **106a**, **106b**, which in turn are sandwiched between passive polymer layers **110a**, **110b**. A conductive bus bar **108** is provided on an inactive area of the EAP film. A conductive contact **114** having a piercing configuration is driven, either manually or otherwise, through one side of the transducer to a depth that penetrates the bus bar material **108**. A conductive trace **116** extends along PCB/flex connector **112** from the exposed end of piercing contact **114**. This method of forming vias is particularly efficient as it eliminates the steps of drilling the via holes, filling the via holes, placing a conductive wire in the via holes and potting the via holes.

[00109] The thickness mode EAP transducers of the present invention are usable in a variety of actuator applications with any suitable construct and surface feature presentation. Figs. 20A-24 illustrate exemplary thickness mode transducer/actuator applications.

[00110] Fig. 20A illustrates a thickness mode transducer **120** having a round construct which is ideal for button actuators for use in tactile or haptic feedback applications in which a user physically contacts a device, e.g., keyboards, touch screens, phones, etc. Transducer **120** is formed from a thin elastomeric dielectric polymer layer **122** and top and bottom electrode patterns **124a**, **124b** (the bottom electrode pattern is shown in phantom), best shown in the isolated view in Fig. 20B. Each of the electrode patterns **124** provides a stem portion **125** with a plurality of oppositely extending finger portions **127** forming a concentric pattern. The stems of the two electrodes are positioned diametrically to each other on opposite sides of the round dielectric layer **122** where their respective finger portions are in appositional alignment with each other to produce the pattern shown in Fig. 20A. While the opposing electrode patterns in this embodiment are identical and symmetrical to each other, other embodiments are contemplated where the

opposing electrode patterns are asymmetric, in shape and/or the amount of surface area which they occupy. The portions of the transducer material in which the two electrode materials do not overlap define the inactive portions **128a**, **128b** of the transducer. An electrical contact **126a**, **126b** is provided at the base of each of the two electrode stem portions for electrically coupling the transducer to a source of power and control electronics (neither are shown). When the transducer is activated, the opposing electrode fingers are drawn together, thereby compressing dielectric material **122** therebetween with the inactive portions **128a**, **128b** of the transducer bulging to form surface features about the perimeter of the button and/or internally to the button as desired.

[00111] The button actuator may be in the form of a single input or contact surface or may be provided in an array format having a plurality of contact surfaces. When constructed in the form of arrays, the button transducers of Fig. 20A are ideal for use in keypad actuators **130**, as illustrated in Fig. 21, for a variety of user interface devices, e.g., computer keyboards, phones, calculators, etc. Transducer array **132** includes a top array **136a** of interconnected electrode patterns and bottom array **136b** (shown in phantom) of electrode patterns with the two arrays opposed with each other to produce the concentric transducer pattern of Fig. 20A with active and inactive portions as described. The keyboard structure may be in the form of a passive layer **134** atop transducer array **132**. Passive layer **134** may have its own surface features, such as key border **138**, which may be raised in the passive state to enable the user to tactilely align his/her fingers with the individual key pads, and/or further amplify the bulging of the perimeter of the respective buttons upon activation. When a key is pressed, the individual transducer upon which it lays is activated, causing the thickness mode bulging as described above, to provide the tactile sensation back to the user. Any number of transducers may be provided in this manner and spaced apart to accommodate the type and size of keypad **134** being used. Examples of fabrication techniques for such transducer arrays are disclosed in U.S. Patent Application No. 12/163,554 filed on June 27, 2008 entitled ELECTROACTIVE POLYMER TRANSDUCERS FOR SENSORY FEEDBACK APPLICATIONS, which is incorporated by reference in its entirety.

[00112] Those skilled in the art will appreciate that the thickness mode transducers of the present invention need not be symmetrical and may take on any construct and shape. The subject transducers may be used in any imaginable novelty application, such as the novelty hand device **140** illustrated in Fig. 22. Dielectric material **142** in the form of a human hand is provided having top and bottom electrode patterns **144a**, **144b** (the underside pattern being shown in phantom) in a similar hand shape. Each of the electrode patterns is

electrically coupled to a bus bar **146a**, **146b**, respectively, which in turn is electrically coupled to a source of power and control electronics (neither are shown). Here, the opposing electrode patterns are aligned with or atop each other rather than interposed, thereby creating alternating active and inactive areas. As such, instead of creating raised surface features on only the internal and external edges of the pattern as a whole, raised surface features are provided throughout the hand profile, i.e., on the inactive areas. It is noted that the surface features in this exemplary application may offer a visual feedback rather than a tactile feedback. It is contemplated that the visual feedback may be enhanced by coloring, reflective material, etc.

[00113] The transducer film of the present invention may be efficiently mass produced, particularly where the transducer electrode pattern is uniform or repeating, by commonly used web-based manufacturing techniques. As shown in Fig. 23, the transducer film **150** may be provided in a continuous strip format having continuous top and bottom electrical buses **156a**, **156b** deposited or formed on a strip of dielectric material **152**. Most typically, the thickness mode features are defined by discrete (i.e., not continuous) but repeating active regions **158** formed by top and bottom electrode patterns **154a**, **154b** electrically coupled to the respective bus bars **156a**, **156b**; the size, length, shape and pattern of which may be customized for the particular application. However, it is contemplated that the active region(s) may be provided in a continuous pattern. The electrode and bus patterns may be formed by known web-based manufacturing techniques, with the individual transducers then singulated, also by known techniques such as by cutting strip **150** along selected singulation lines **155**. It is noted that where the active regions are provided continuously along the strip, the strip is required to be cut with a high degree of precision to avoid shorting the electrodes. The cut ends of these electrodes may require potting or otherwise may be etched back to avoid tracking problems. The cut terminals of buses **156a**, **156b** are then coupled to sources of power/control to enable actuation of the resulting actuators.

[00114] Either prior to or after singulation, the strip or singulated strip portions, may be stacked with any number of other transducer film strips/strip portions to provide a multi-layer structure. The stacked structure may then be laminated and mechanically coupled, if so desired, to rigid mechanical components of the actuator, such an output bar or the like.

[00115] Fig. 24 illustrates another variation of the subject transducers in which a transducer **160** formed by a strip of dielectric material **162** with top and bottom electrodes **164a**, **164b** on opposing sides of the strip arranged in a rectangular pattern thereby framing an open area **165**. Each of the electrodes terminates in an electrical bus **166a**, **166b**, respectively, having an electrical contact point **168a**, **168b** for coupling to a source of power and control electronics

(neither being shown). A passive layer (not shown) that extends across the enclosed area **165** may be employed on either side of the transducer film, thereby forming a gasket configuration, for both environmental protection and mechanical coupling of the output bars (also not shown). As configured, activation of the transducer produces surface features along the inside and outside perimeters **169** of the transducer strip and a reduction in thickness of the active areas **164a 164b**. It should be noted that the gasket actuator need not be a continuous, single actuator. One or more discrete actuators can also be used to line the perimeter of an area which may be optionally sealed with non-active compliant gasket material

[00116] Other gasket-type actuators are disclosed in U.S. Patent Application No. 12/163,554, referenced above. These types of actuators are suitable for sensory (e.g., haptic or vibratory) feedback applications such as with touch sensor plates, touch pads and touch screens for application in handheld multimedia devices, medical instrumentation, kiosks or automotive instrument panels, toys and other novelty products, etc.

[00117] Figs. 25A-25D are cross-sectional views of touch screens employing variations of a thickness mode actuator of the present invention with like reference numbers referencing similar components amongst the four figures. Referring to Fig. 25A, the touch screen device **170** may include a touch sensor plate **174**, typically made of a glass or plastic material, and, optionally, a liquid crystal display (LCD) **172**. The two are stacked together and spaced apart by EAP thickness mode actuator **180** defining an open space **176** therebetween. The collective stacked structure is held together by frame **178**. Actuator **180** includes the transducer film formed by dielectric film layer **182** sandwiched centrally by electrode pair **184a, 184b**. The transducer film is in turn sandwiched between top and bottom passive layers **186a, 186b** and further held between a pair of output structures **188a, 188b** which are mechanically coupled to touch plate **174** and LCD **172**, respectively. The right side of Fig. 25A shows the relative position of the LCD and touch plate when the actuator is inactive, while the left side of Fig. 25A shows the relative positions of the components when the actuator is active, i.e., upon a user depressing touch plate **174** in the direction of arrow **175**. As is evident from the left side of the drawing, when actuator **180** is activated, the electrodes **184a, 184b** are drawn together thereby compressing the portion of dielectric film **182** therebetween while creating surface features in the dielectric material and passive layers **186a, 186b** outside the active area, which surface features are further enhanced by the compressive force caused by output blocks **188a, 188b**. As such, the surface features provide a slight force on touch plate **174** in the direction opposite arrow **175** which gives the user a tactile sensation in response to depressing the touch plate.

[00118] Touch screen device **190** of Fig. 25B has a similar construct to that of Fig. 25A with the difference being that LCD **172** wholly resides within the internal area framed by

the rectangular (or square, etc.) shaped thickness mode actuator **180**. As such, the spacing **176** between LCD **172** and touch plate **174** when the device is in an inactive state (as demonstrated on the right side of the figure) is significantly less than in the embodiment of Fig. 25A, thereby providing a lower profile design. Further, the bottom output structure **188b** of the actuator rests directly on the back wall **178'** of frame **178**. Irrespective of the structural differences between the two embodiments, device **190** functions similarly to device **170** in that the actuator surface features provide a slight tactile force in the direction opposite arrow **185** in response to depressing the touch plate.

[00119] The two touch screen devices just described are single phase devices as they function in a single direction. Two (or more) of the subject gasket-type actuators may be used in tandem to produce a two phase (bi-directional) touch screen device **200** as in Fig. 25C. The construct of device **200** is similar to that of the device of Fig. 25B but with the addition of a second thickness mode actuator **180'** which sits atop touch plate **174**. The two actuators and touch plate **174** are held in stacked relation by way of frame **178** which has an added inwardly extending top shoulder **178''**. As such, touch plate **174** is sandwiched directly between the innermost output blocks **188a**, **188b'** of actuators **180**, **180'**, respectively, while the outermost output blocks **188b**, **188a'** of actuators **180'**, respectively, buttress the frame members **178'** and **178''**, respectively. This enclosed gasket arrangement keeps dust and debris out of the optical path within space **176**. Here, the left side of the figure illustrates bottom actuator **180** in an active state and top actuator **180'** in a passive state in which sensor plate **174** is caused to move towards LCD **172** in the direction of arrow **195**. Conversely, the right side of the figure illustrates bottom actuator **180** in a passive state and top actuator **180'** in an active state in which sensor plate **174** is caused to move away from LCD **172** in the direction of arrow **195'**.

[00120] Fig. 25D illustrates another two phase touch sensor device **210** but with a pair of thickness mode strip actuators **180** oriented with the electrodes orthogonal to the touch sensor plate. Here, the two phase or bi-directional movement of touch plate **174** is in-plane as indicated by arrow **205**. To enable such in-plane motion, the actuator **180** is positioned such that the plane of its EAP film is orthogonal to those of LCD **172** and touch plate **174**. To maintain such a position, actuator **180** is held between the sidewall **202** of frame **178** and an inner frame member **206** upon which rests touch plate **174**. While inner frame member **206** is affixed to the output block **188a** of actuator **180**, it and touch plate **174** are "floating" relative to outer frame **178** to allow for the in-plane or lateral motion. This construct provides a relatively compact, low-profile design as it eliminates the added clearance that would otherwise be necessary for two-phase out-of-plane motion by touch plate **174**. The two actuators work in opposition for two-phase motion. The combined assembly of plate **174** and brackets **206** keep the actuator strips **180** in slight compression

against the sidewall 202 of frame 178. When one actuator is active, it compresses or thins further while the other actuator expands due to the stored compressive force. This moves the plate assembly toward the active actuator. The plate moves in the opposite direction by deactivating the first actuator and activating the second actuator.

[00121] Figs. 26A and 26B illustrate variation in which an inactive area of a transducer is positioned internally or centrally to the active region(s), i.e., the central portion of the EAP film is devoid of overlapping electrodes. Thickness mode actuator 360 includes EAP transducer film comprising dielectric layer 362 sandwiched between electrode layers 364a, 364b in which a central portion 365 of the film is passive and devoid of electrode material. The EAP film is held in a taut or stretched condition by at least one of top and bottom frame members 366a, 366b, collectively providing a cartridge configuration. Covering at least one of the top and bottom sides of the passive portion 365 of the film are passive layers 368a, 368b with optional rigid constraints or output members 370a, 370b mounted thereon, respectively. With the EAP film constrained at its perimeter by cartridge frame 366, when activated (see Fig. 26B), the compression of the EAP film causes the film material to retract inward, as shown by arrows 367a, 367b, rather than outward as with the above-described actuator embodiments. The compressed EAP film impinges on the passive material 368a, 368b causing its diameter to decrease and its height to increase. This change in configuration applies outward forces on output members 370a, 370b, respectively. As with the previously described actuator embodiments, the passively coupled film actuators may be provided in multiples in stacked or planar relationships to provide multi-phase actuation and/or to increase the output force and/or stroke of the actuator.

[00122] Performance may be enhanced by prestraining the dielectric film and/or the passive material. The actuator may be used as a key or button device and may be stacked or integrated with sensor devices such as membrane switches. The bottom output member or bottom electrode can be used to provide sufficient pressure to a membrane switch to complete the circuit or can complete the circuit directly if the bottom output member has a conductive layer. Multiple actuators can be used in arrays for applications such as keypads or keyboards.

[00123] The various dielectric elastomer and electrode materials disclosed in U.S. Patent Application Publication No. 2005/0157893 are suitable for use with the thickness mode transducers of the present invention. Generally, the dielectric elastomers include any substantially insulating, compliant polymer, such as silicone rubber and acrylic, that deforms in response to an electrostatic force or whose deformation results in a change in electric field. In designing or choosing an appropriate polymer, one may consider the optimal material, physical, and chemical properties. Such properties can be tailored by

judicious selection of monomer (including any side chains), additives, degree of cross-linking, crystallinity, molecular weight, etc.

[00124] Electrodes described therein and suitable for use include structured electrodes comprising metal traces and charge distribution layers, textured electrodes, conductive greases such as carbon greases or silver greases, colloidal suspensions, high aspect ratio conductive materials such as conductive carbon black, carbon fibrils, carbon nanotubes, graphene and metal nanowires, and mixtures of ionically conductive materials. The electrodes may be made of a compliant material such as elastomer matrix containing carbon or other conductive particles. The present invention may also employ metal and semi-inflexible electrodes.

[00125] Exemplary passive layer materials for use in the subject transducers include but are not limited to silicone, styrenic or olefinic copolymer, polyurethane, acrylate, rubber, a soft polymer, a soft elastomer (gel), soft polymer foam, or a polymer/gel hybrid, for example. The relative elasticity and thickness of the passive layer(s) and dielectric layer are selected to achieve a desired output (e.g., the net thickness or thinness of the intended surface features), where that output response may be designed to be linear (e.g., the passive layer thickness is amplified proportionally to the that of the dielectric layer when activated) or non-linear (e.g., the passive and dielectric layers get thinner or thicker at varying rates).

[00126] Regarding methodology, the subject methods may include each of the mechanical and/or activities associated with use of the devices described. As such, methodology implicit to the use of the devices described forms part of the invention. Other methods may focus on fabrication of such devices.

[00127] As for other details of the present invention, materials and alternate related configurations may be employed as within the level of those with skill in the relevant art. The same may hold true with respect to method-based aspects of the invention in terms of additional acts as commonly or logically employed. In addition, though the invention has been described in reference to several examples, optionally incorporating various features, the invention is not to be limited to that which is described or indicated as contemplated with respect to each variation of the invention. Various changes may be made to the invention described and equivalents (whether recited herein or not included for the sake of some brevity) may be substituted without departing from the true spirit and scope of the invention. Any number of the individual parts or subassemblies shown may be integrated in their design. Such changes or others may be undertaken or guided by the principles of design for assembly.

[00128] In another variation, the cartridge assembly or actuator 360 can be suited for use in providing a haptic response in a vibrating button, key, touchpad, mouse, or other interface.

In such an example, coupling of the actuator **360** employs a non-compressible output geometry. This variation provides an alternative from a bonded center constraint of an electroactive polymer diaphragm cartridge by using a non-compressible material molded into the output geometry.

[00129] In an electroactive polymer actuator with no center disc, actuation changes the condition of the Passive Film in the center of the electrode geometry, decreasing both the stress and the strain (force and displacement). This decrease occurs in all directions in the plane of the film, not just a single direction. Upon the discharge of the electroactive polymer, the Passive film then returns to an original stress and strain energy state. An electroactive polymer actuator can be constructed with a non-compressible material (one that has a substantially constant volume under stress). The actuator **360** is assembled with a non-compressible output pad **368a 368b** bonded to the passive film area at the center of the actuator **360** in the inactive region **365**, replacing the center disk. This configuration can be used to transfer energy by compressing the output pad at its interface with the passive portion **365**. This swells the output pad **368a** and **368b** to create actuation in the direction orthogonal to the flat film. The non compressible geometry can be further enhanced by adding constraints to various surfaces to control the orientation of its change during actuation. For the above example, adding a non-compliant stiffener to constrain the top surface of the output pad prevents that surface from changing its dimension, focusing the geometry change to desired dimensions of the output pad.

[00130] The variation described above can also allow coupling of biaxial stress and strain state changes of electroactive polymer Dielectric Elastomer upon actuation; transfers actuation orthogonal to direction of actuation; design of non-compressible geometry to optimize performance. The variations described above can include various transducer platforms, including: diaphragm, planar, inertial drive, thickness mode, hybrid (combination of planar & thickness mode described in the attached disclosure), and even roll – for any haptic feedback (mice, controllers, screens, pads, buttons, keyboards, etc.) These variations might move a specific portion of the user contact surface, e.g. a touch screen, keypad, button or key cap, or move the entire device.

[00131] Different device implementations may require different EAP platforms. For example, in one example, strips of thickness mode actuators might provide out-of-plane motion for touch screens, hybrid or planar actuators to provide key click sensations for buttons on keyboards, or inertial drive designs to provide rumbler feedback in mice and controllers.

[00132] Fig. 27A illustrates another variation of a transducer for providing haptic feedback with various user interface devices. In this variation, a mass or weight **262** is coupled to an

electroactive polymer actuator **30**. Although the illustrated polymer actuator comprises a film cartridge actuator, alternative variations of the device can employ a spring biased actuator as described in the EAP patents and applications disclosed above.

[00133] Fig. 27B illustrates an exploded view of the transducer assembly of Fig. 27A. As illustrated the inertial transducer assembly **260** includes a mass **262** sandwiched between two actuators **30**. However, variations of the device include one or more actuators depending upon the intended application on either side of the mass. As illustrated, the actuator(s) is/are coupled to the inertial mass **262** and secured via a base-plate or flange. Actuation of the actuators **30** causes movement of the mass in an x-y orientation relative to the actuator. In additional variations, the actuators can be configured to provide a normal or z axis movement of the mass **262**.

[00134] Fig. 27C illustrates a side view of the inertial transducer assembly **260** of Fig. 27A. In this illustration, the assembly is shown with a center housing **266** and a top housing **268** that enclose the actuators **30** and inertial mass **262**. Also, the assembly **260** is shown with fixation means or fasteners **270** extending through openings or vias **24** within the housing and actuators. The vias **24** can serve multiple functions. For example, the vias can be for mounting purposes only. Alternatively, or in combination, the vias can electrically couple the actuator to a circuit board, flex circuit or mechanical ground. Fig. 27D illustrates a perspective view of the inertial transducer assembly **260** of Fig. 27C where the inertial mass (not shown) is located within a housing assembly **264**, **266**, and **268**). The parts of the housing assembly can serve multiple functions. For example, in addition to providing mechanical support and mounting and attachment features, they can incorporate features that serve as mechanical hard stops to prevent excessive motion of the inertial mass in x, y, and/or z directions which could damage the actuator cartridges. For example, the housing can include raised surfaces to limit excessive movement of the inertial mass. In the illustrated example, the raised surfaces can comprise the portion of the housing that contains the vias **24**. Alternatively, the vias **24** can be placed selectively so that any fastener **270** located therethrough functions as an effective stop to limit movement of the inertial mass.

[00135] Housing assemblies can **264** and **266** can also be designed with integrated lips or extensions that cover the edges of the actuators to prevent electrical shock on handling. Any and all of these parts can also be integrated as part of the housing of a larger assembly such as the housing of a consumer electronic device. For example, although the illustrated housing is shown as a separate component that is to be secured within a user interface device, alternate variations of the transducer include housing assemblies that are integral or

part of the housing of the actual user interface device. For instance, a body of a computer mouse can be configured to serve as the housing for the inertial transducer assembly.

[00136] The inertial mass 262 can also serve multiple functions. While it is shown as circular in Figs. 27A and 27B to, variations of the inertial mass can be fabricated to have a more complex shape such that it has integrated features that serve as mechanical hard stops that limit its motion in x, y, and/or z directions. For example, Fig. 27E illustrates a variation of an inertial transducer assembly with an inertial mass 262 having a shaped surface 263 that engage a stop or other feature of the housing 264. In the illustrated variation, the surface 263 of the inertial mass 262 engages fasteners 270. Accordingly, the displacement of the inertial mass 262 is limited to the gap between the shaped surface 263 and the stop or fastener 270. The mass of the weight can be chosen to tailor the resonant frequency of the total assembly, and the material of construction can be any dense material but is preferably chosen to minimize the required volume and cost. Suitable materials include metals and metal alloys such as copper, steel, tungsten, aluminum, nickel, chrome and brass, and polymer/metal composites materials, resins, fluids, gels, or other materials can be used.

[00137] **FILTER SOUND DRIVE WAVEFORM FOR ELECTROACTIVE POLYMER HAPTICS**

[00138] Another variation of the inventive methods and devices described herein involves driving the actuators in a manner to improve feedback. In one such example the haptic actuator is driven by a sound signal. Such a configuration eliminates the need for a separate processor to generate waveforms to produce different types of haptic sensations. Instead, haptic devices can employ one or more circuits to modify an existing audio signal into a modified haptic signal, e.g. filtering or amplifying different portions of the frequency spectrum. Therefore, the modified haptic signal then drives the actuator. In one example, the modified haptic signal drives the power supply to trigger the actuator to achieve different sensory effects. This approach has the advantages of being automatically correlated with and synchronized to any audio signal which can reinforce the feedback from the music or sound effects in a haptic device such as a gaming controller or handheld gaming console.

[00139] Fig. 28A illustrates one example of a circuit to tune an audio signal to work within optimal haptic frequencies for electroactive polymer actuators. The illustrated circuit modifies the audio signal by amplitude cutoff, DC offset adjustment, and AC waveform peak-to-peak magnitude adjustment to produce a signal similar to that shown in Fig. 28B. In certain variations, the electroactive polymer actuator comprises a two phase electroactive polymer actuator and where altering the audio signal comprises filtering a positive portion

of an audio waveform of the audio signal to drive a first phase of the electroactive polymer transducer, and inverting a negative portion of the audio waveform of the audio signal to drive a second phase of the electro active polymer transducer to improve performance of the electro active polymer transducer. For example, a source audio signal in the form of a sine wave can be converted to a square wave (e.g., via clipping), so that the haptic signal is a square wave that produces maximum actuator force output.

[00140] In another example, the circuit can include one or more rectifiers to filter the frequency of an audio signal to use all or a portion of an audio waveform of the audio signal to drive the haptic effect. Fig. 28C illustrates one variation of a circuit designed to filter a positive portion of an audio waveform of an audio signal. This circuit can be combined, in another variation, with the circuit shown in Fig. 28D for actuators having two phases. As shown, the circuit of Fig. 28C can filter positive portions of an audio waveform to drive one phase of the actuator while the circuit shown in Fig. 28D can invert a negative portion of an audio waveform to drive the other phase of the 2-phase haptic actuator. The result is that the two phase actuator will have a greater actuator performance.

[00141] In another implementation, a threshold in the audio signal can be used to trigger the operation of a secondary circuit which drives the actuator. The threshold can be defined by the amplitude, the frequency, or a particular pattern in the audio signal. The secondary circuit can have a fixed response such as an oscillator circuit set to output a particular frequency or can have multiple responses based on multiple defined triggers. In some variations, the responses can be pre-determined based upon a particular trigger. In such a case, stored response signals can be provided in upon a particular trigger. In this manner, instead of modifying the source signal, the circuit triggers a pre-determined response depending upon one or more characteristics of the source signal. The secondary circuit can also include a timer to output a response of limited duration.

[00142] Many systems could benefit from the implementation of haptics with capabilities for sound, (e.g. computers, Smartphones, PDA's, electronic games). In this variation, filtered sound serves as the driving waveform for electroactive polymer haptics. The sound files normally used in these systems can be filtered to include only the optimal frequency ranges for the haptic feedback actuator designs. Figs. 28E and 28F illustrate one such example of a device 400, in this case a computer mouse, having one or more electroactive polymer actuators 402 within the mouse body 400 and coupled to an inertial mass 404.

[00143] Current systems operate at optimal frequencies of <200Hz. A sound waveform, such as the sound of a shotgun blast, or the sound of a door closing, can be low pass filtered to allow only the frequencies from these sounds that are <200 Hz to be used. This filtered waveform is then supplied as the input waveform to the EPAM power supply that drives

the haptic feedback actuator. If these examples were used in a gaming controller, the sound of the shotgun blast and the closing door would be simultaneous to the haptic feedback actuator, supplying an enriched experience to the game player.

[00144] In one variation use of an existing sound signal can allow for a method of producing a haptic effect in a user interface device simultaneously with the sound generated by the separately generated audio signal. For example, the method can include routing the audio signal to a filtering circuit; altering the audio signal to produce a haptic drive signal by filtering a range of frequencies below a predetermined frequency; and providing the haptic drive signal to a power supply coupled to an electroactive polymer transducer such that the power supply actuates the electroactive polymer transducer to drive the haptic effect simultaneously to the sound generated by the audio signal.

[00145] The method can further include driving the electroactive polymer transducer to simultaneously generate both a sound effect and a haptic response.

[00146] As for other details of the present invention, materials and alternate related configurations may be employed as within the level of those with skill in the relevant art. The same may hold true with respect to method-based aspects of the invention in terms of additional acts as commonly or logically employed. In addition, though the invention has been described in reference to several examples, optionally incorporating various features, the invention is not to be limited to that which is described or indicated as contemplated with respect to each variation of the invention. Various changes may be made to the invention described and equivalents (whether recited herein or not included for the sake of some brevity) may be substituted without departing from the true spirit and scope of the invention. Any number of the individual parts or subassemblies shown may be integrated in their design. Such changes or others may be undertaken or guided by the principles of design for assembly.

[00147] Also, it is contemplated that any optional feature of the inventive variations described may be set forth and claimed independently, or in combination with any one or more of the features described herein. Reference to a singular item, includes the possibility that there are plural of the same items present. More specifically, as used herein and in the appended claims, the singular forms "a," "an," "said," and "the" include plural referents unless the specifically stated otherwise. In other words, use of the articles allow for "at least one" of the subject item in the description above as well as the claims below. It is further noted that the claims may be drafted to exclude any optional element. As such, this statement is intended to serve as antecedent basis for use of such exclusive terminology as "solely," "only" and the like in connection with the recitation of claim elements, or use of a "negative" limitation. Without the use of such exclusive terminology, the term

“comprising” in the claims shall allow for the inclusion of any additional element – irrespective of whether a given number of elements are enumerated in the claim, or the addition of a feature could be regarded as transforming the nature of an element set forth in the claims. Stated otherwise, unless specifically defined herein, all technical and scientific terms used herein are to be given as broad a commonly understood meaning as possible while maintaining claim validity.

[00148] In all, the breadth of the present invention is not to be limited by the examples provided. That being said, we claim:

What is claimed is:

1. A method of producing a haptic effect in a user interface device simultaneously with a sound generated by a separately generated audio signal, the method comprising:
 - routing the audio signal to a filtering circuit;
 - altering the audio signal to produce a haptic drive signal by filtering a range of frequencies below a predetermined frequency; and
 - providing the haptic drive signal to a power supply coupled to an electroactive polymer transducer such that the power supply actuates the electroactive polymer transducer to drive the haptic effect simultaneously to the sound generated by the audio signal.
2. The method of claim 1, further comprising driving the electroactive polymer transducer to generate a sound effect using the filtered signal.
3. The method of claim 1, where the predetermined frequency comprises an optimal frequency of the electroactive polymer actuator.
4. The method of claim 1, where the pre-determined frequency comprises 200 hertz.
5. The method of claim 1, wherein altering the audio signal comprises filtering the positive portion of an audio waveform of the audio signal to produce the haptic signal.
6. The method of claim 1, wherein the electroactive polymer comprises a two phase electroactive polymer actuator and where altering the audio signal comprises filtering a positive portion of an audio waveform of the audio signal to drive a first phase of the electroactive polymer transducer, and inverting a negative portion of the audio waveform of the audio signal to drive a second phase of the electro active polymer transducer to improve performance of the electro active polymer transducer.
7. The method of claim 1, the audio signal comprises a sine waveform, and where altering the audio signal comprises converting the sine wave form to produce the haptic drive signal having a square waveform.
8. A method of producing a haptic effect in a user interface device simultaneously with a sound generated by a separately generated audio signal, the method comprising:
 - routing the audio signal to a triggering circuit;
 - generating a haptic drive signal based on a characteristic of the audio signal; and
 - providing the haptic drive signal to a power supply coupled to an electroactive

polymer transducer such that the power supply actuates the electroactive polymer transducer to drive the haptic effect by controlling a haptic output frequency of the electroactive polymer transducer.

9. The method of claim 8, further comprising driving the electroactive polymer transducer to generate a sound effect using the filtered signal.
10. The method of claim 8, where the characteristic of the audio signal comprises a threshold voltage of the audio signal.
11. A transducer comprising:
 - an electroactive polymer film comprising a dielectric elastomer layer, wherein a portion of the dielectric elastomer layer is stretched between first and second electrodes wherein at least one overlapping portion of the electrodes defines an active film region with at least one remaining portion of film defining an inactive film region;
 - a first conductive layer disposed on at least a portion of the inactive film region and electrically coupled to the first electrode, and a second conductive layer disposed on at least a portion of the inactive film region and electrically coupled to the second electrode; and
 - at least one passive incompressible polymer layer, the incompressible polymer layer extending over at least a portion of one side of the electroactive polymer film, wherein activation of the active region changes a thickness dimension of the incompressible passive polymer layer.
12. The transducer of claim 11, further comprising a first conductive via extending through the transducer at a location which includes the first electrode and a second conductive via extending through the transducer at a location which includes the second electrode.
13. The transducer of claim 11, further comprising a first and a second passive incompressible polymer layers, where the first and second passive incompressible polymer layers are located on each side of the electroactive polymer film.
14. A transducer assembly comprising:
 - at least two stacked layers of electroactive polymer film, each electroactive polymer film comprising a thin dielectric elastomer layer, wherein a portion of the dielectric elastomer layer is sandwiched between first and second electrodes wherein the overlapping portions of the electrodes define an active film region with the remaining portion of film defining an inactive film region, wherein the active film regions of the respective layers of electroactive polymer film are in stacked alignment and the inactive active film regions of the respective layers of electroactive polymer film are in stacked

alignment;

a first conductive layer disposed on at least a portion of the inactive film region of each electroactive polymer film and electrically coupled to the first electrode thereof, and a second conductive layer disposed on at least a portion of the inactive film region of each electroactive polymer film and electrically coupled to the second electrode thereof; and

a passive incompressible polymer layer over each exposed side of the electroactive polymer films, wherein activation of the active regions changes a thickness dimension of the passive incompressible polymer layer.

15. The transducer assembly of claim 14, further comprising a first conductive via extending through the stacked electroactive polymer films at a location which includes the first electrode of each film and a second conductive via extending through the stacked electroactive polymer films at a location which includes the second electrodes.
16. An inertial electroactive polymer transducer, comprising:
 - an electroactive polymer film stretched between a top and bottom frame components, where a central portion of frame is open to expose a central surface of the electroactive polymer film;
 - a first output member on the central surface of the electroactive polymer film; and
 - at least one inertial mass affixed to the output disk wherein upon application of voltage difference across a first and second electrodes on the electroactive polymer film causes displacement of the polymer film causing the inertial mass to move.
17. The inertial electroactive polymer transducer of claim 16, further comprising a second electroactive polymer film sandwiched between a top and bottom second frame components, where a central portion of second frame is open to expose a second central surface of the electroactive polymer film; and
 - a second output member on the central surface of the electroactive polymer film, where the inertial mass is located between the affixed between the first and second output members.
18. The inertial electroactive polymer transducer of claim 16, wherein the electroactive polymer is configured to displace in a plane of the electroactive polymer film.
19. The inertial electroactive polymer transducer of claim 16, wherein the electroactive polymer is configured to displace in a direction perpendicular to a plane of the electroactive polymer film.

20. The inertial electroactive polymer transducer of claim 16, wherein the electroactive polymer is spring biased.
21. The inertial electroactive polymer transducer of claim 16, wherein the inertial electroactive polymer transducer further comprises at least one housing assembly.
22. The inertial electroactive polymer transducer of claim 21, wherein the electroactive polymer film and inertial mass are encased within the housing assembly.
23. The inertial electroactive polymer transducer of claim 22, where the housing assembly is configured to electrically insulate the inertial electroactive polymer transducer.
24. The inertial electroactive polymer transducer of claim 21, wherein the housing assembly further comprises at least one mechanical stop to limit movement of the inertial mass to prevent damage to the actuator cartridge resulting from excessive movement.
25. The inertial electroactive polymer transducer of claim 24, where the at least one mechanical stop comprises at least one fastener located within the housing assembly.
26. The inertial electroactive polymer transducer of claim 16, where the inertial mass comprises a shaped surface to engage a stop within the housing to limit movement of the inertial mass to a distance between the shaped surface and the stop to prevent damage to the actuator cartridge resulting from excessive movement.
27. The inertial electroactive polymer transducer of claim 16, where a weight of the inertial mass is selected dependent upon a resonant frequency of the electroactive polymer film.
28. The inertial electroactive polymer transducer of claim 16, where the housing assembly comprises a portion of a housing of a user interface device.

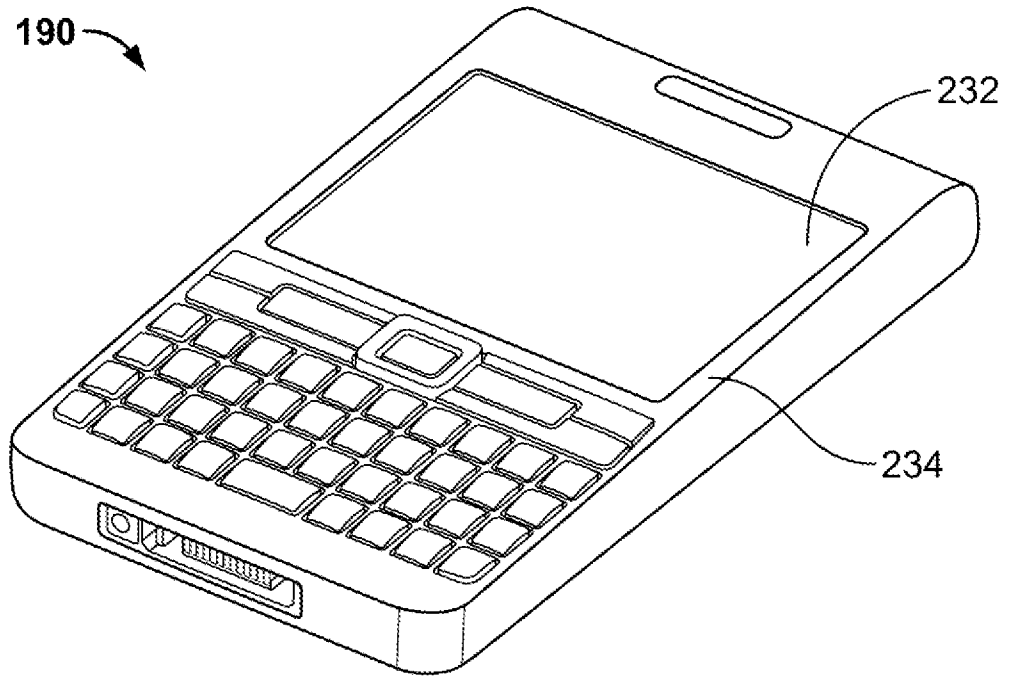

FIG. 1A

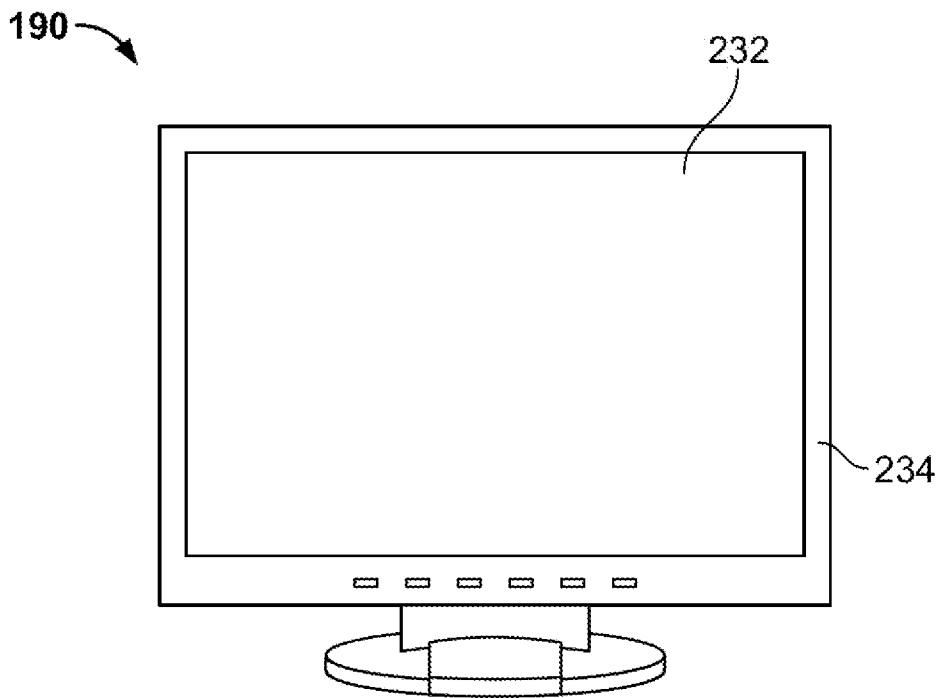

FIG. 1B

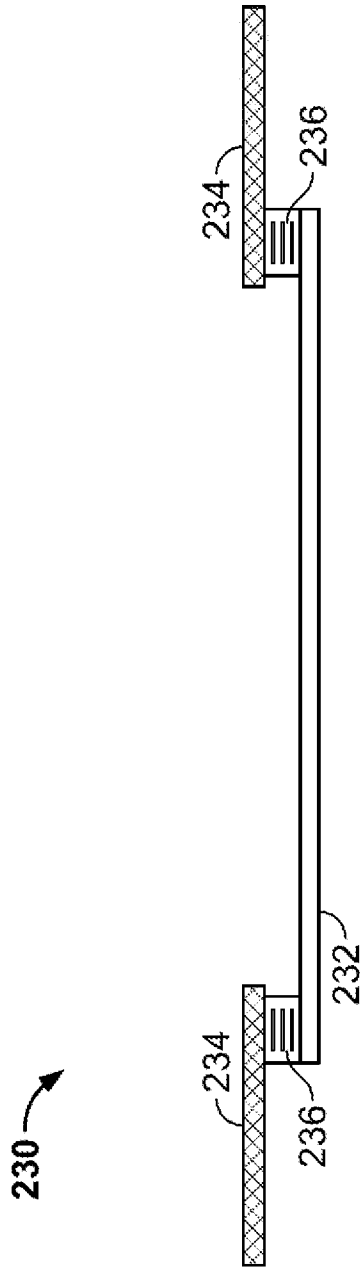

FIG. 2A

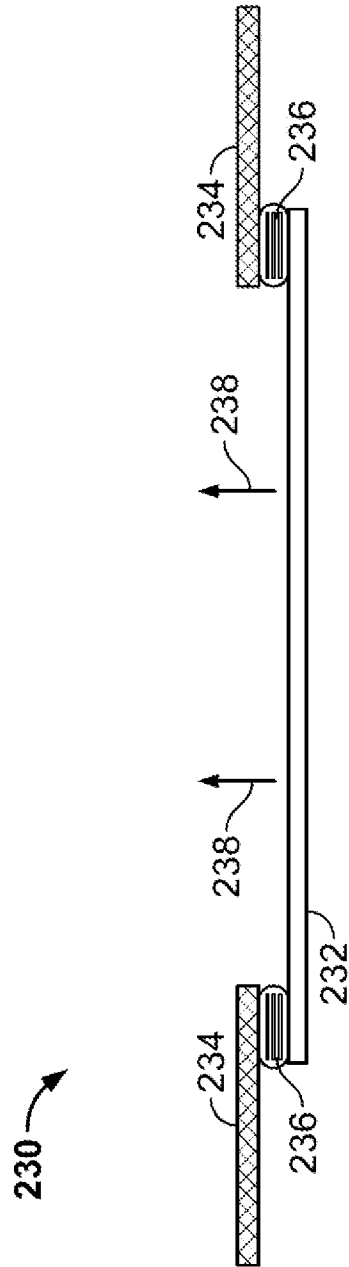

FIG. 2B

230 ↗

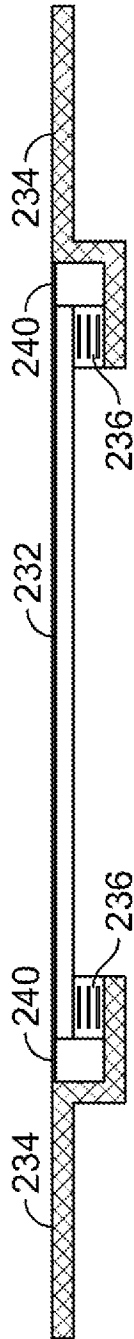

FIG. 3A

230 ↗

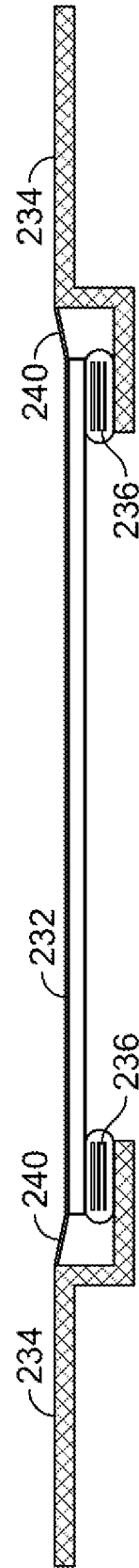

FIG. 3B

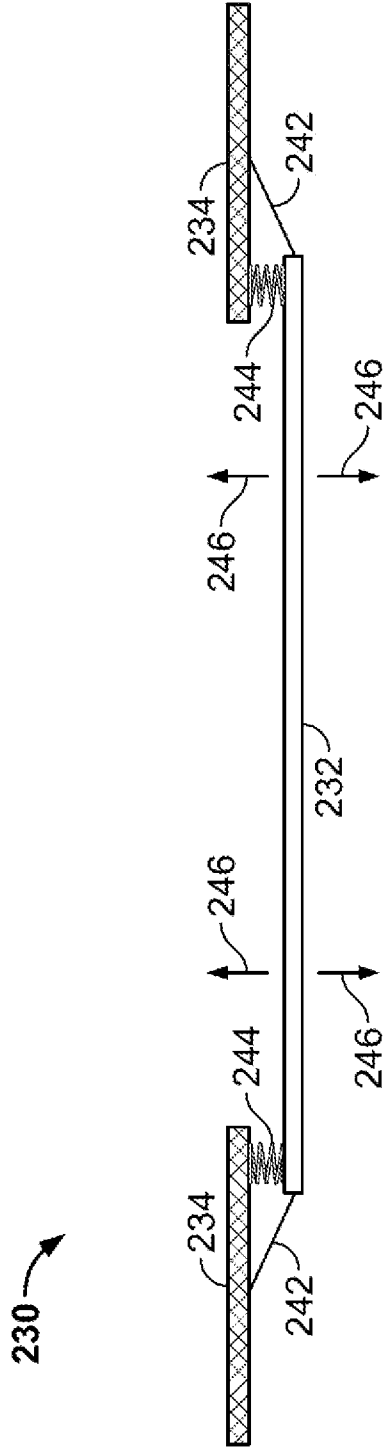

FIG. 4

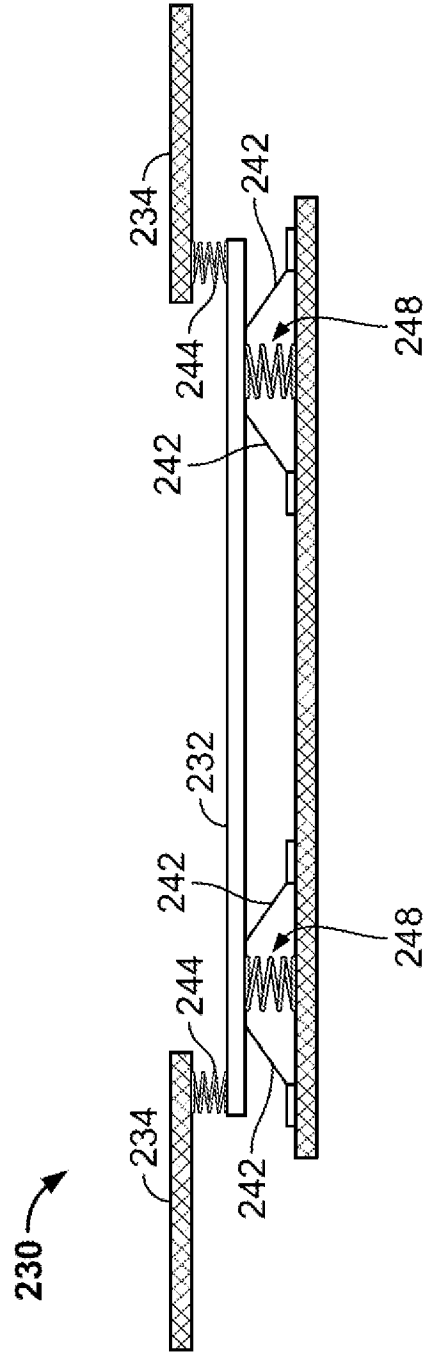

FIG. 5

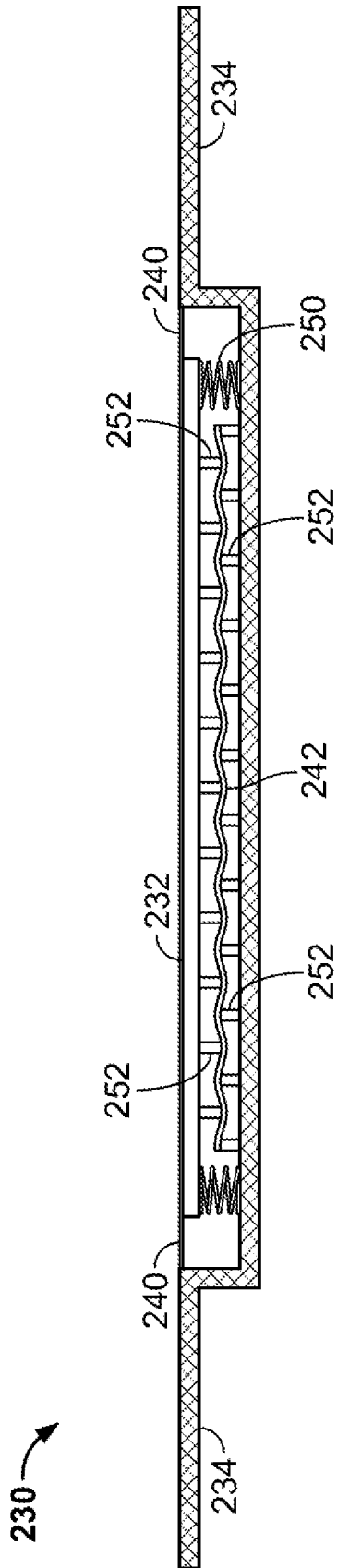

FIG. 6A

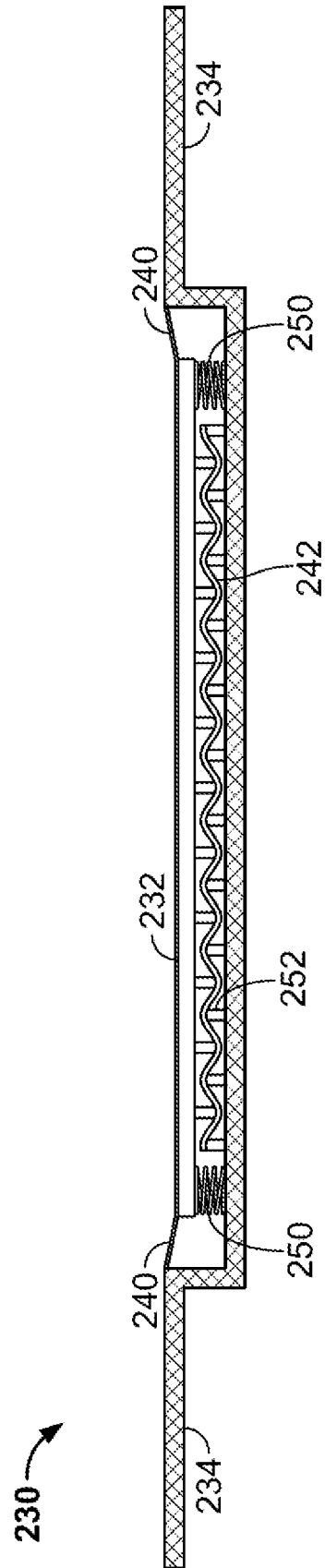

FIG. 6B

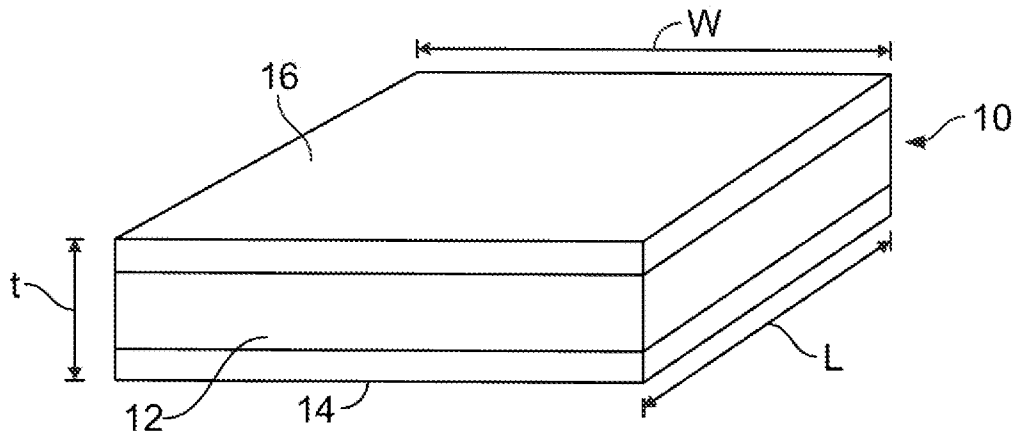

FIG. 7A

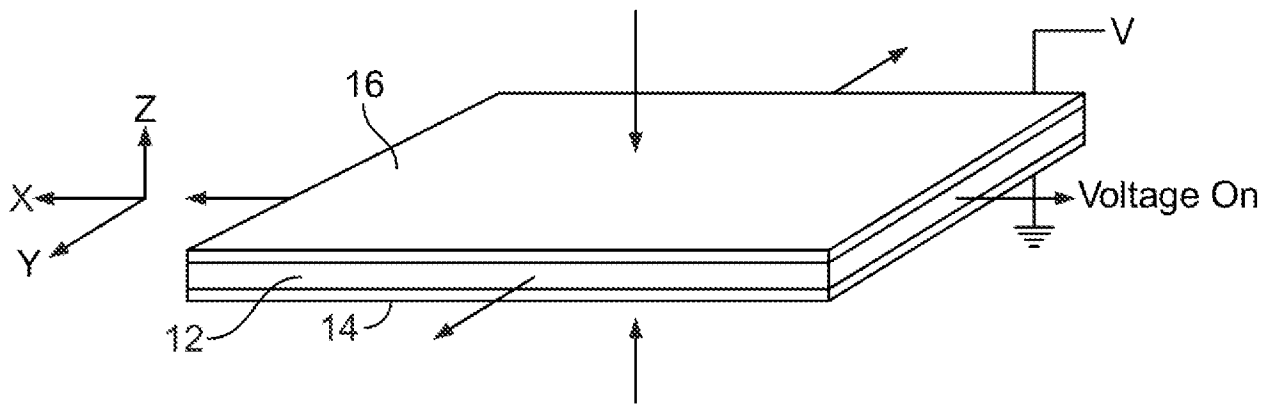

FIG. 7B

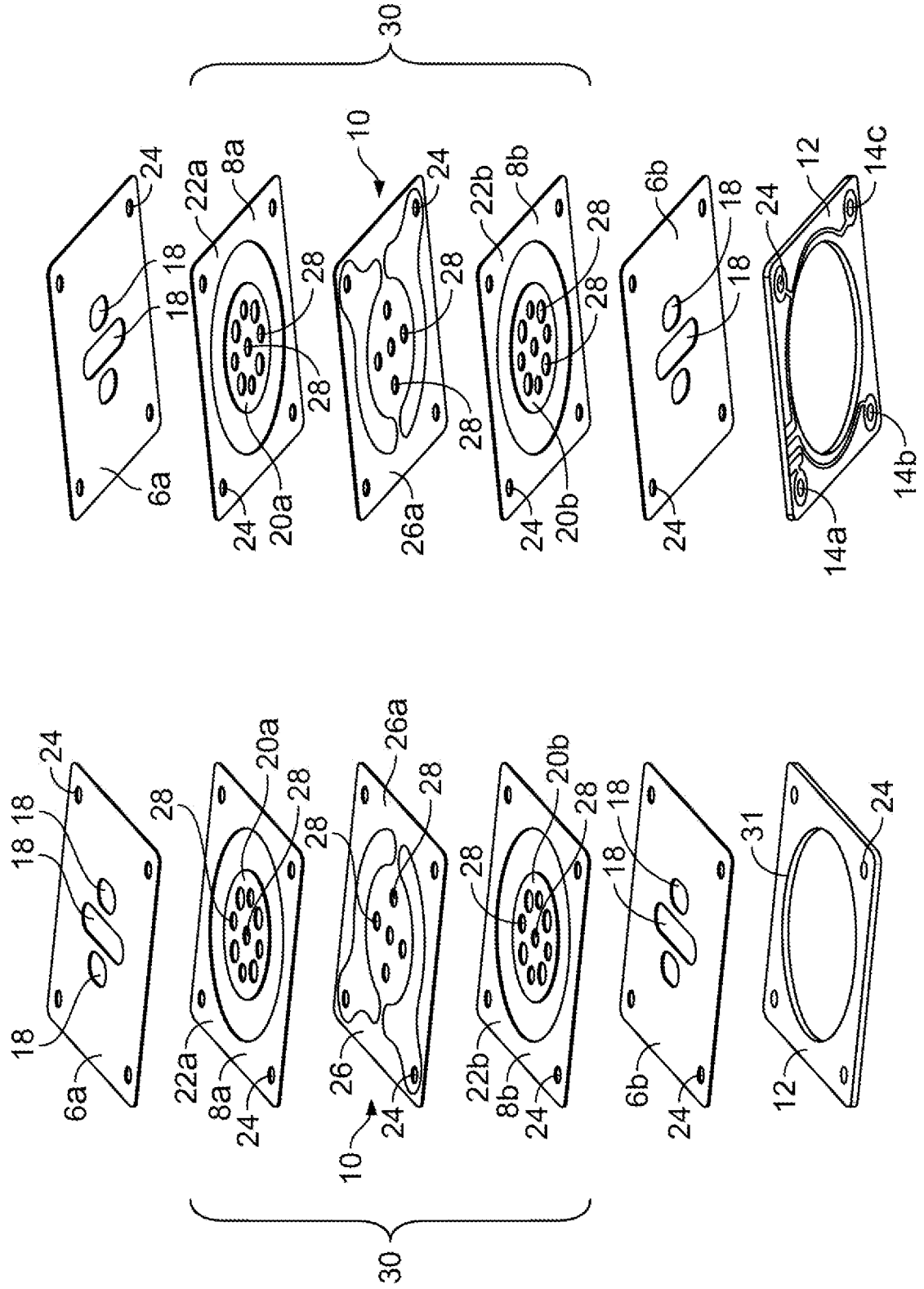

FIG. 8B

FIG. 8A

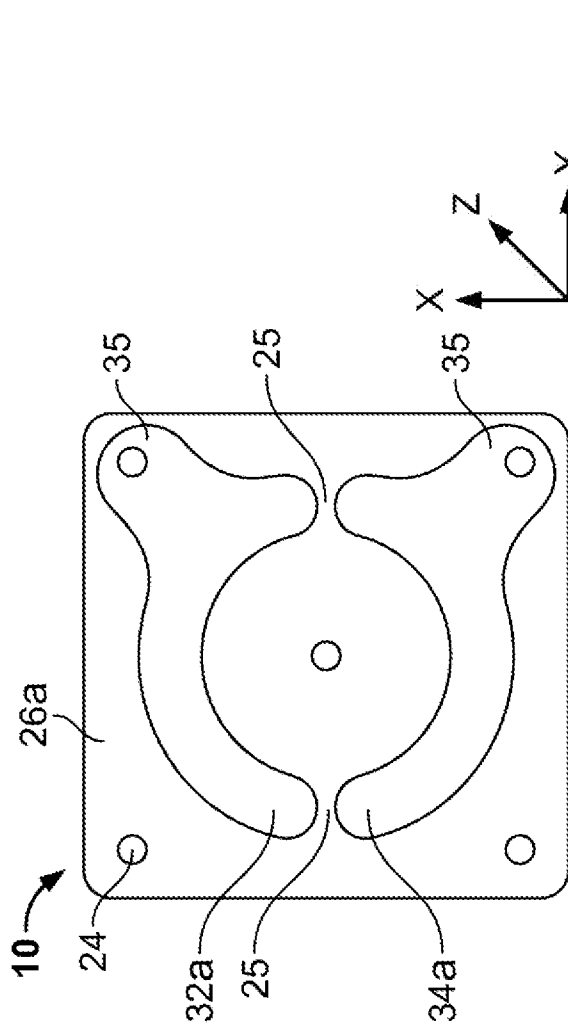
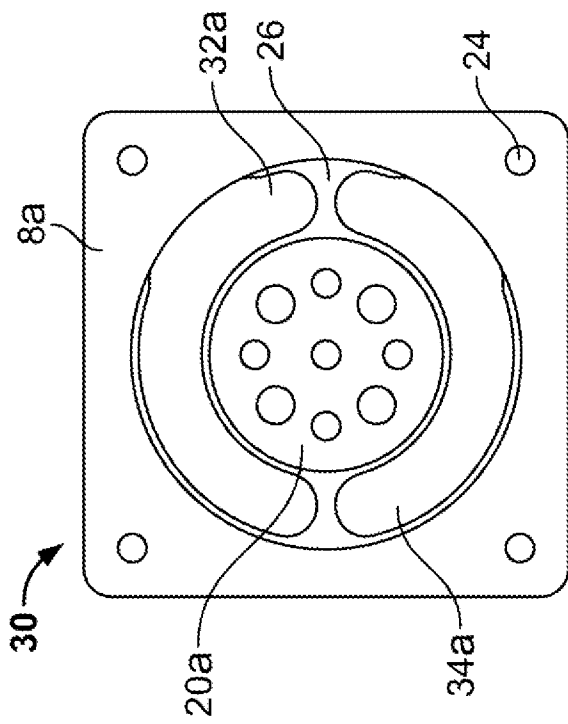

FIG. 9A

FIG. 9B

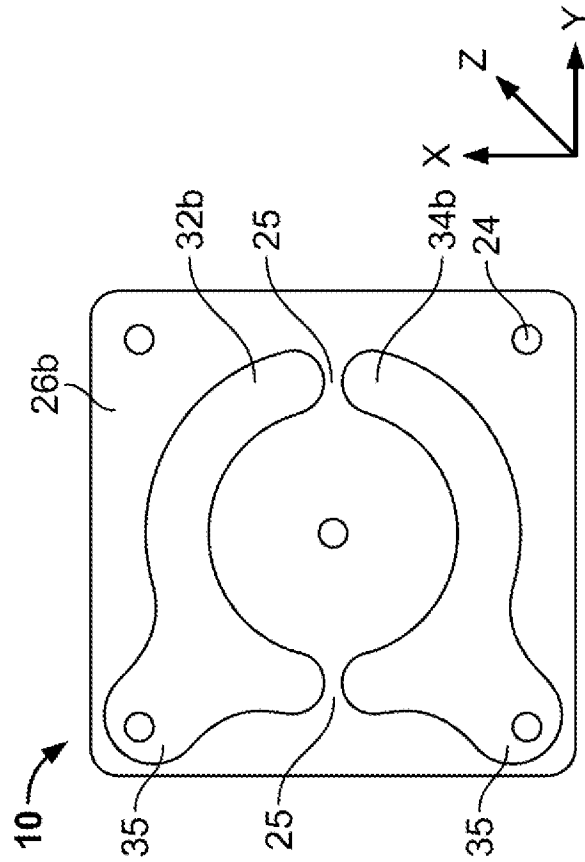

FIG. 9C

FIG. 10

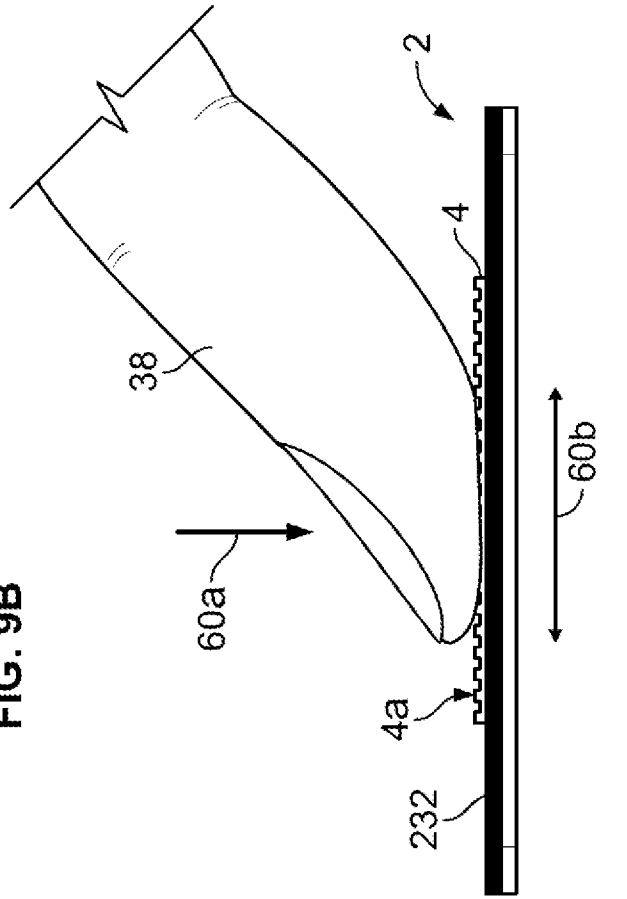

FIG. 9C

FIG. 10

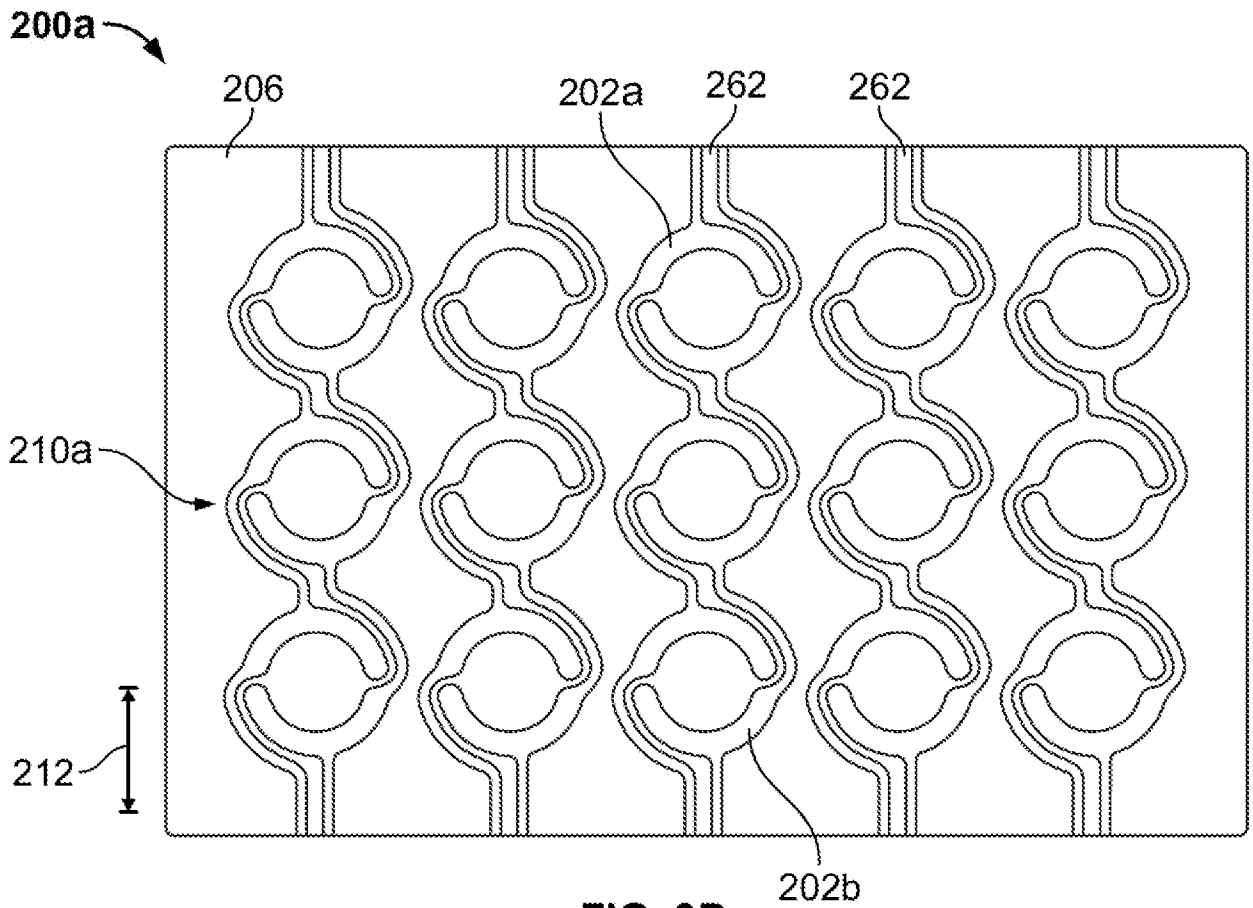

FIG. 9D

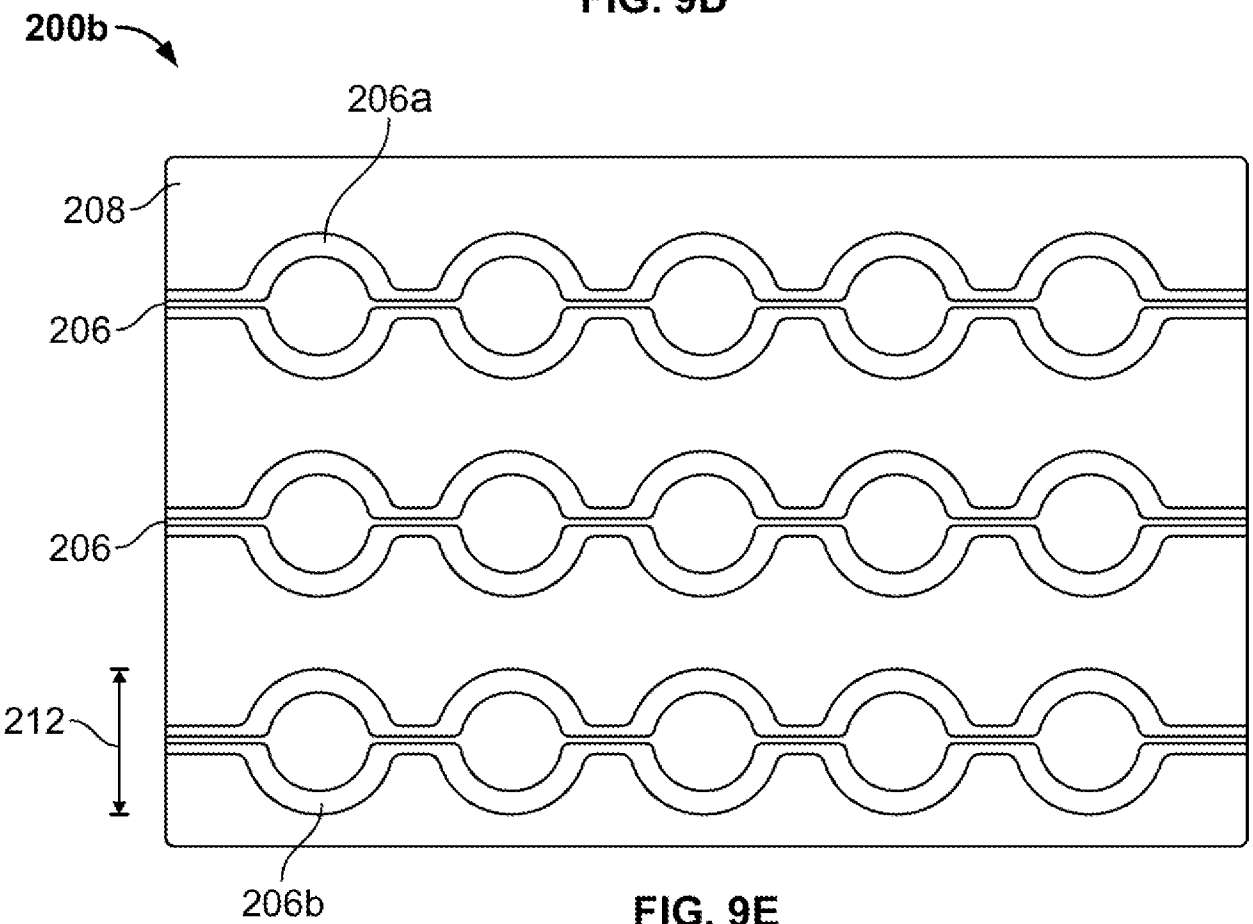

FIG. 9E

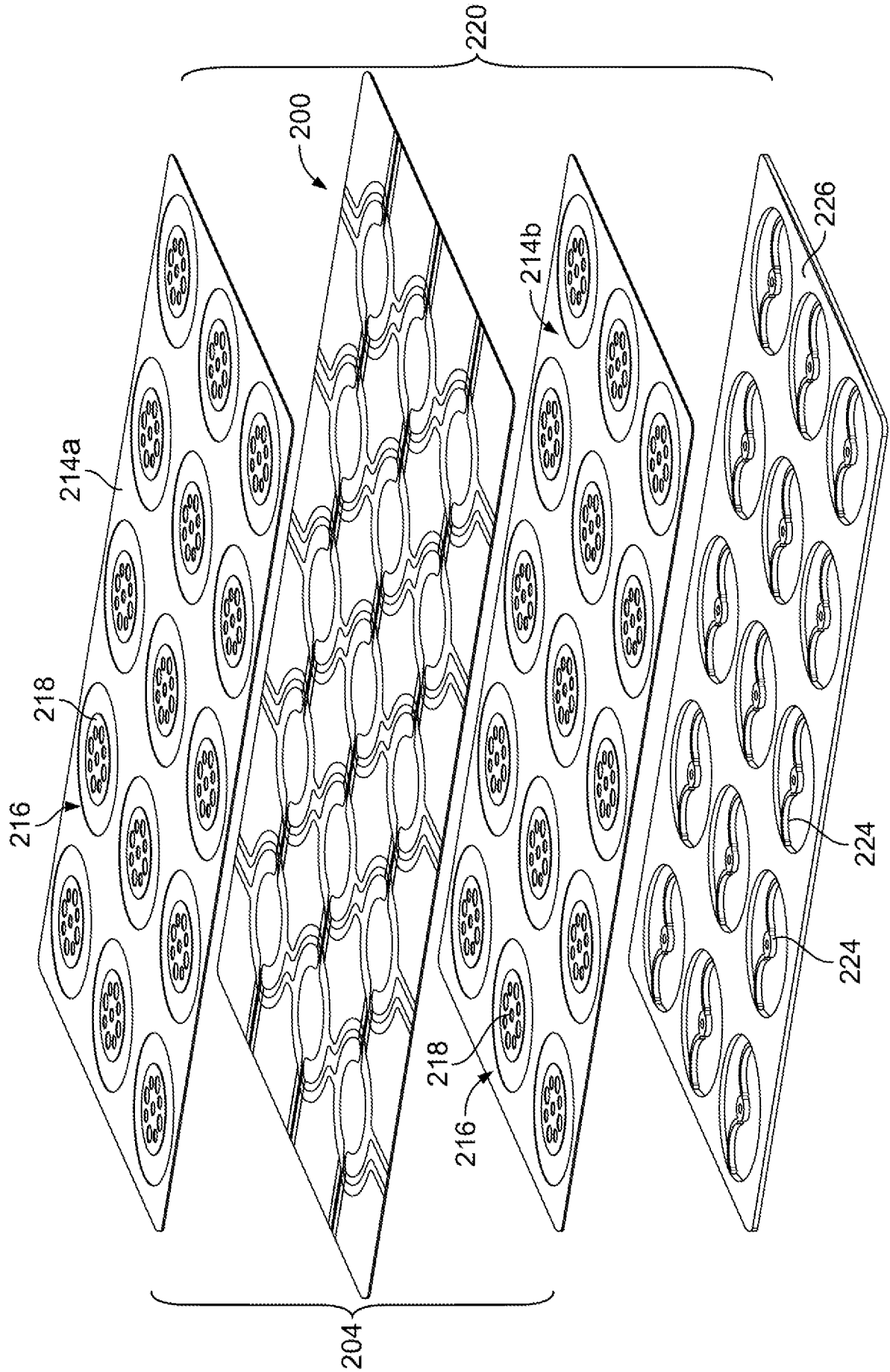

FIG. 9F

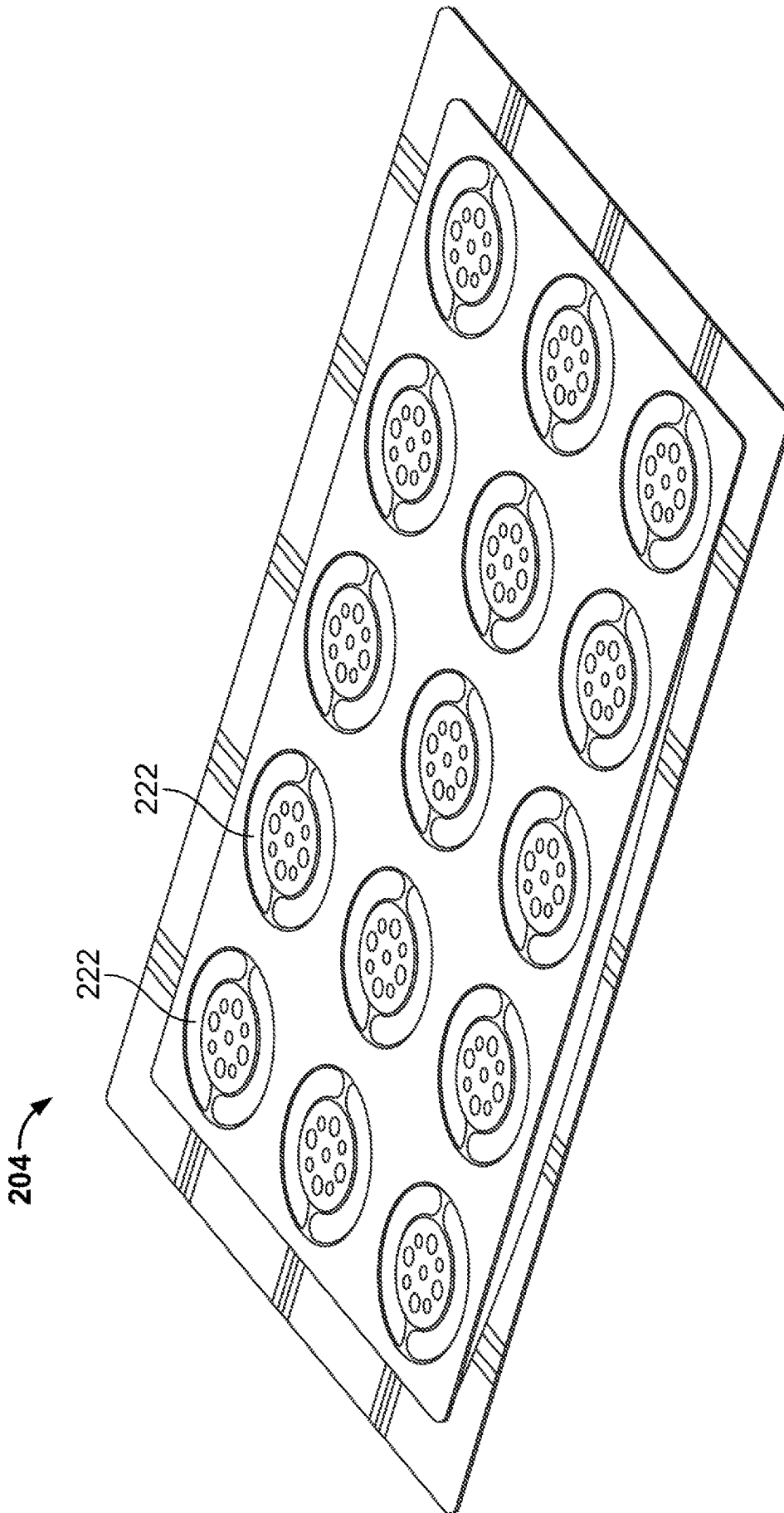

FIG. 9G

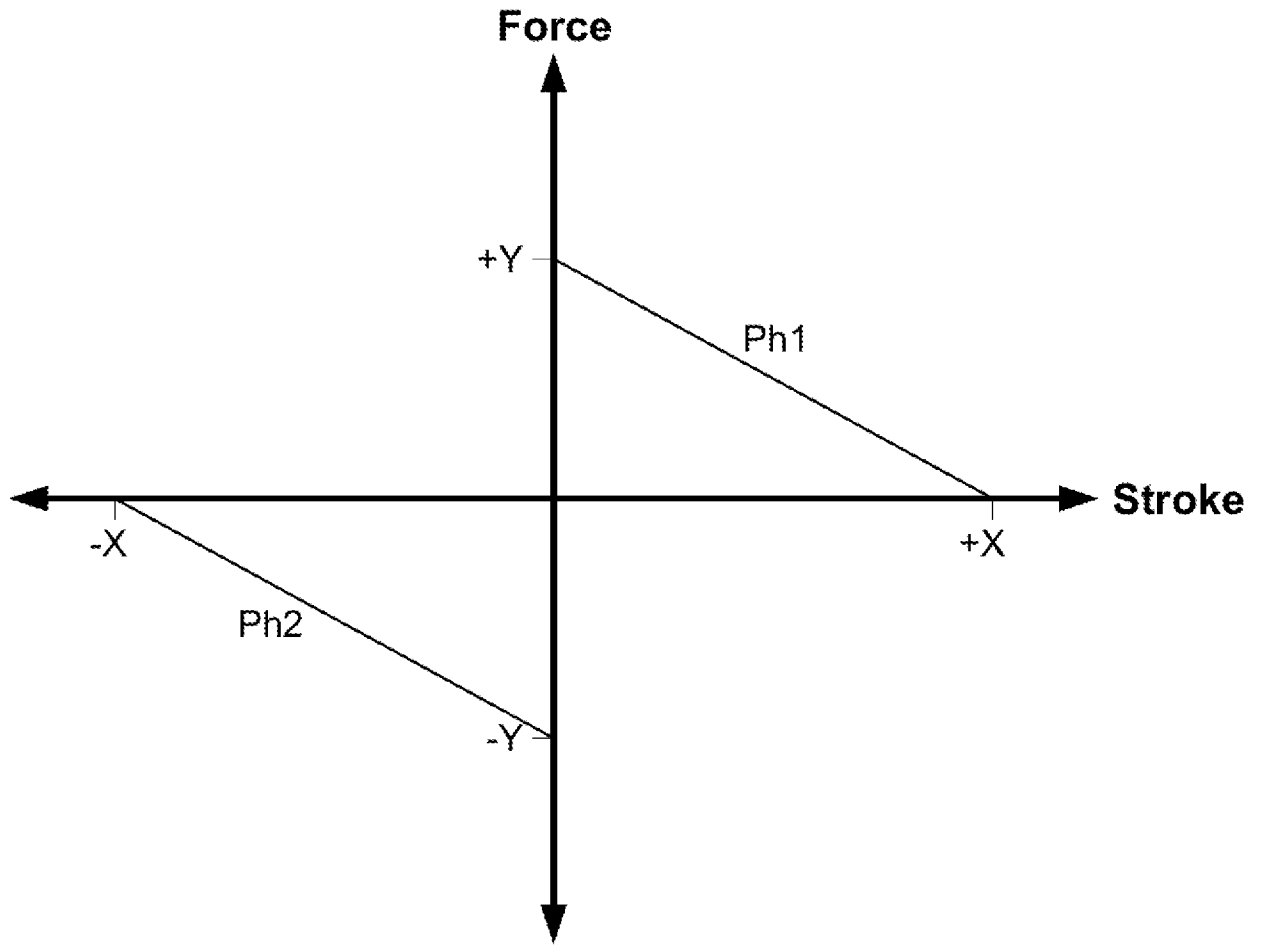

FIG. 11A

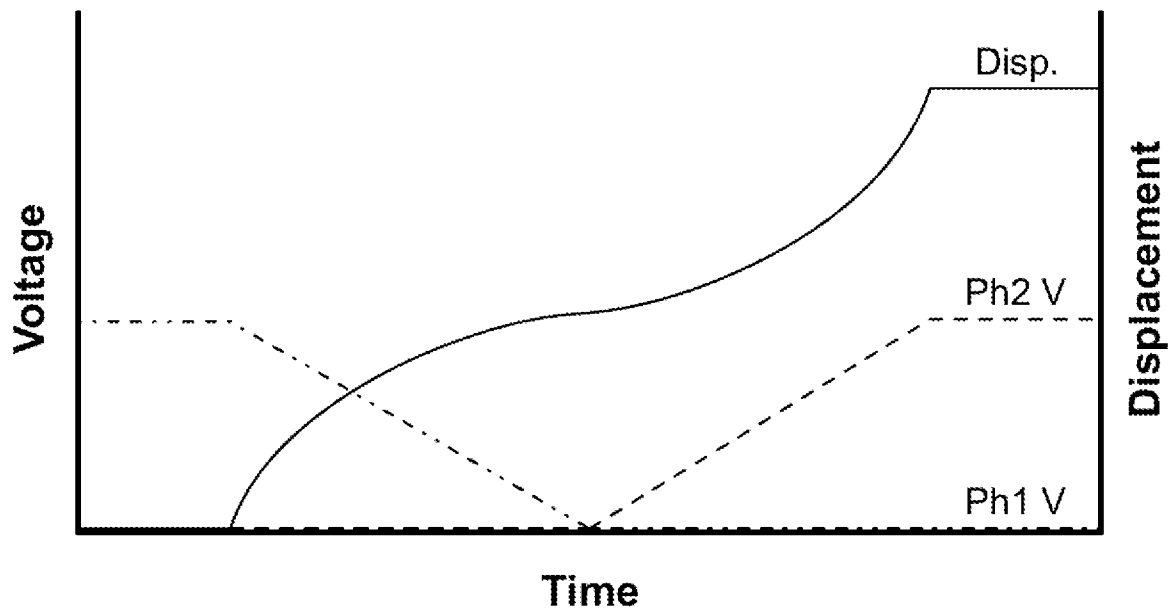

FIG. 11B

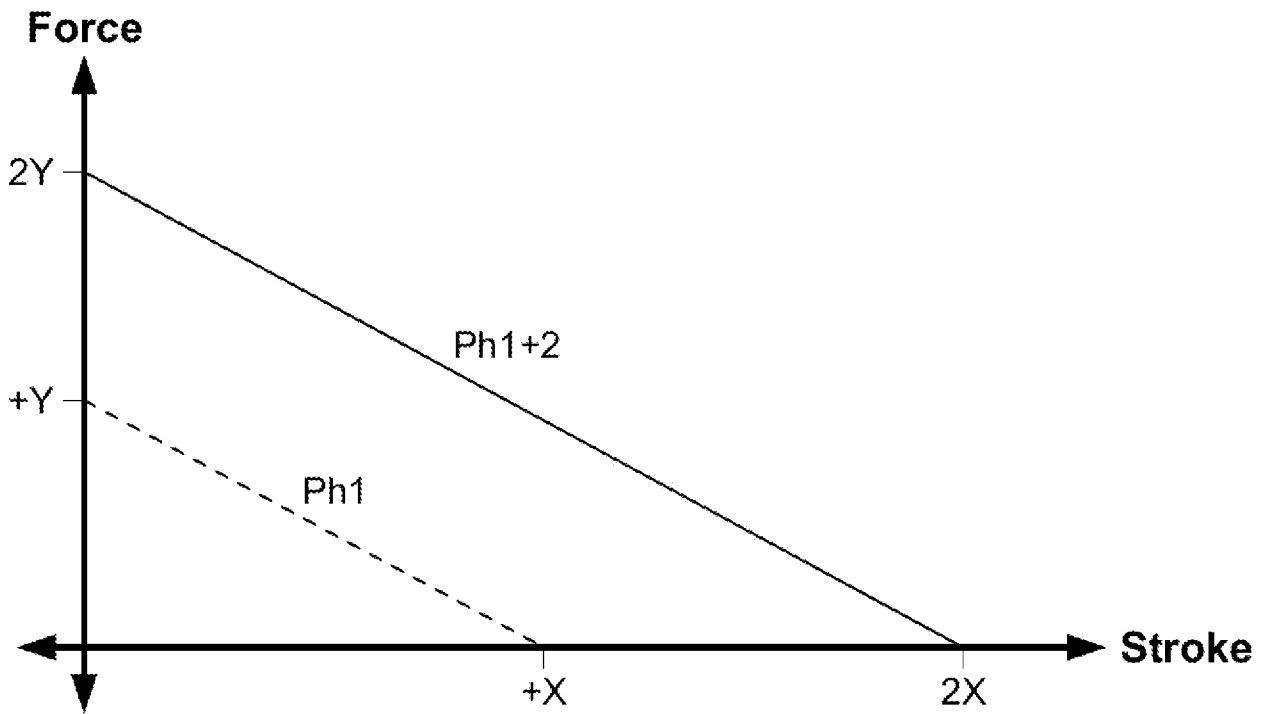

FIG. 12A

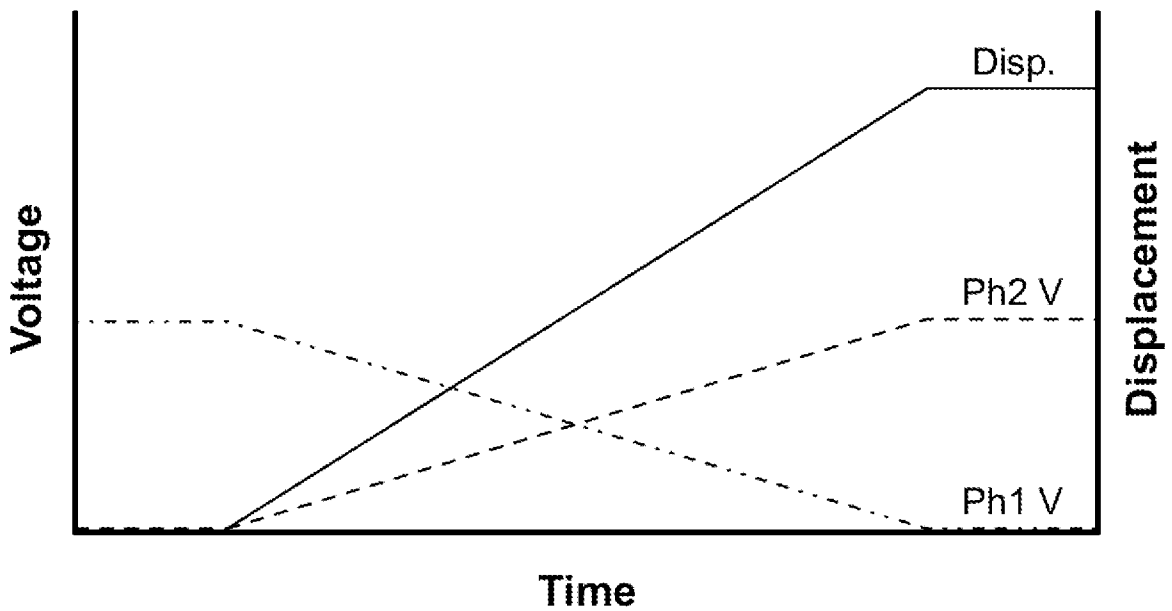

FIG. 12B

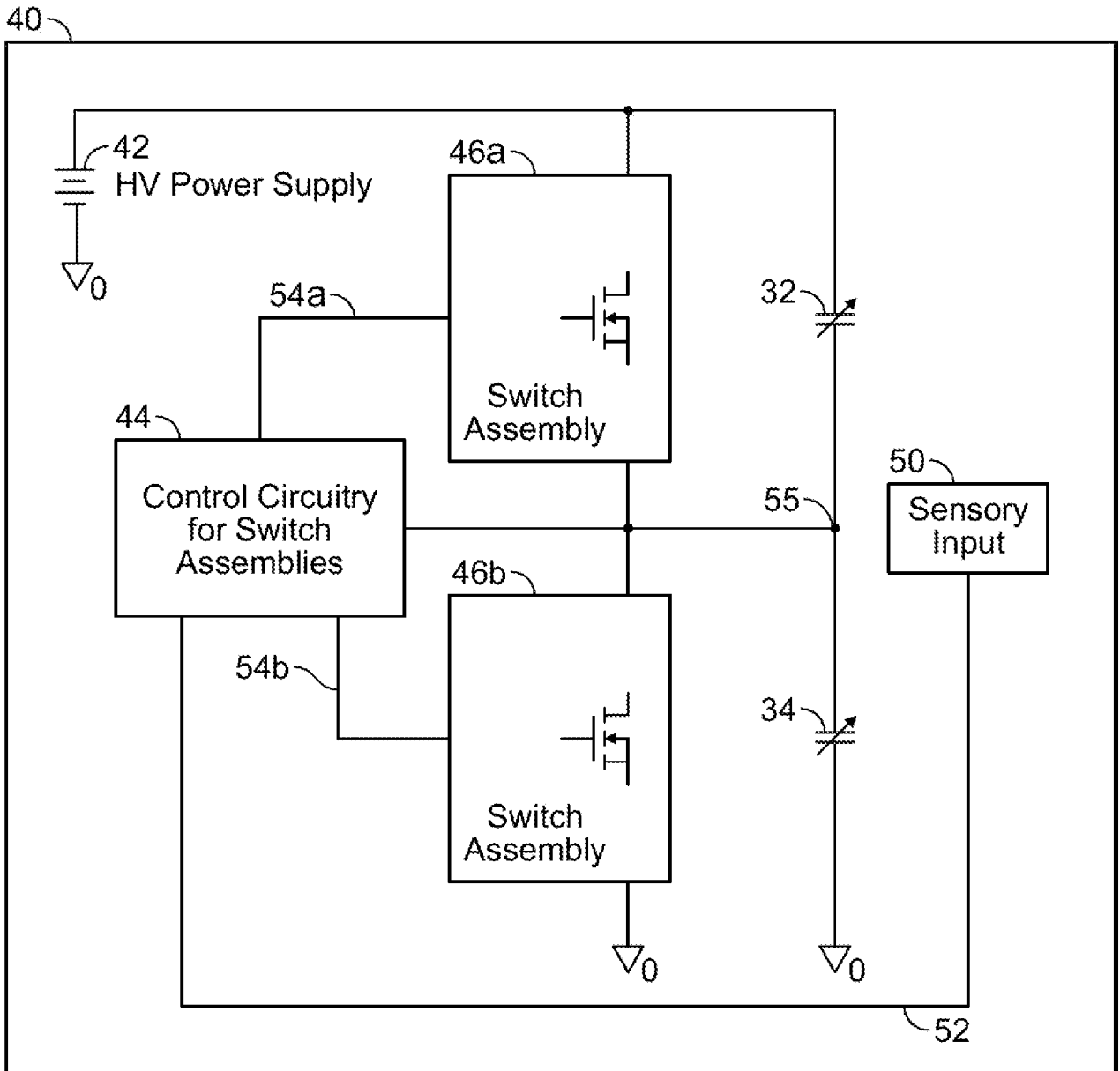

FIG. 13

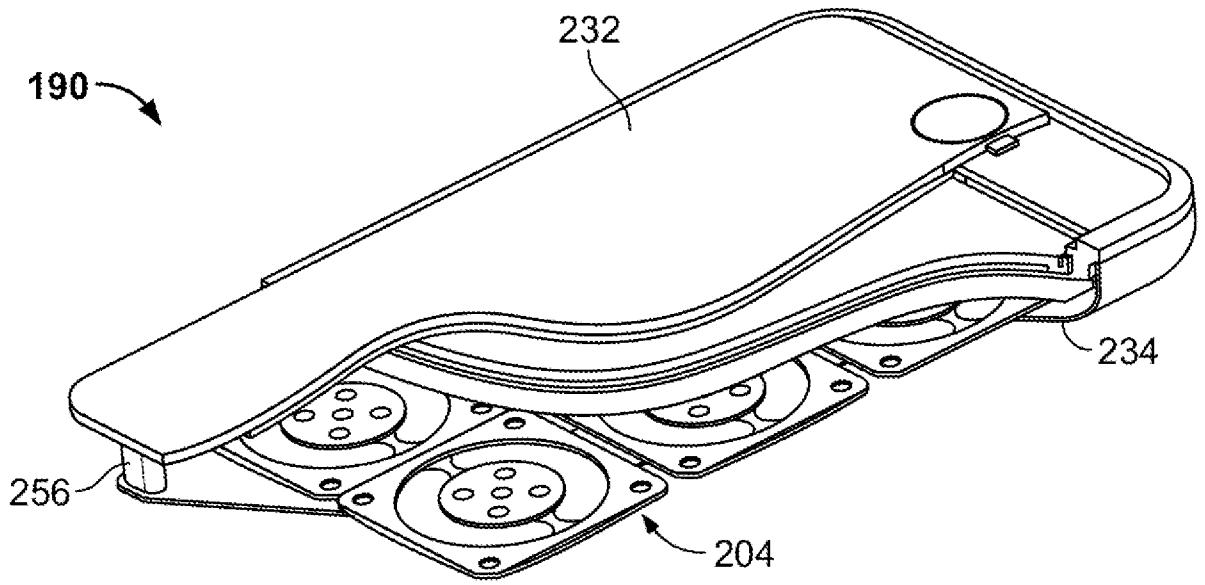

FIG. 14A

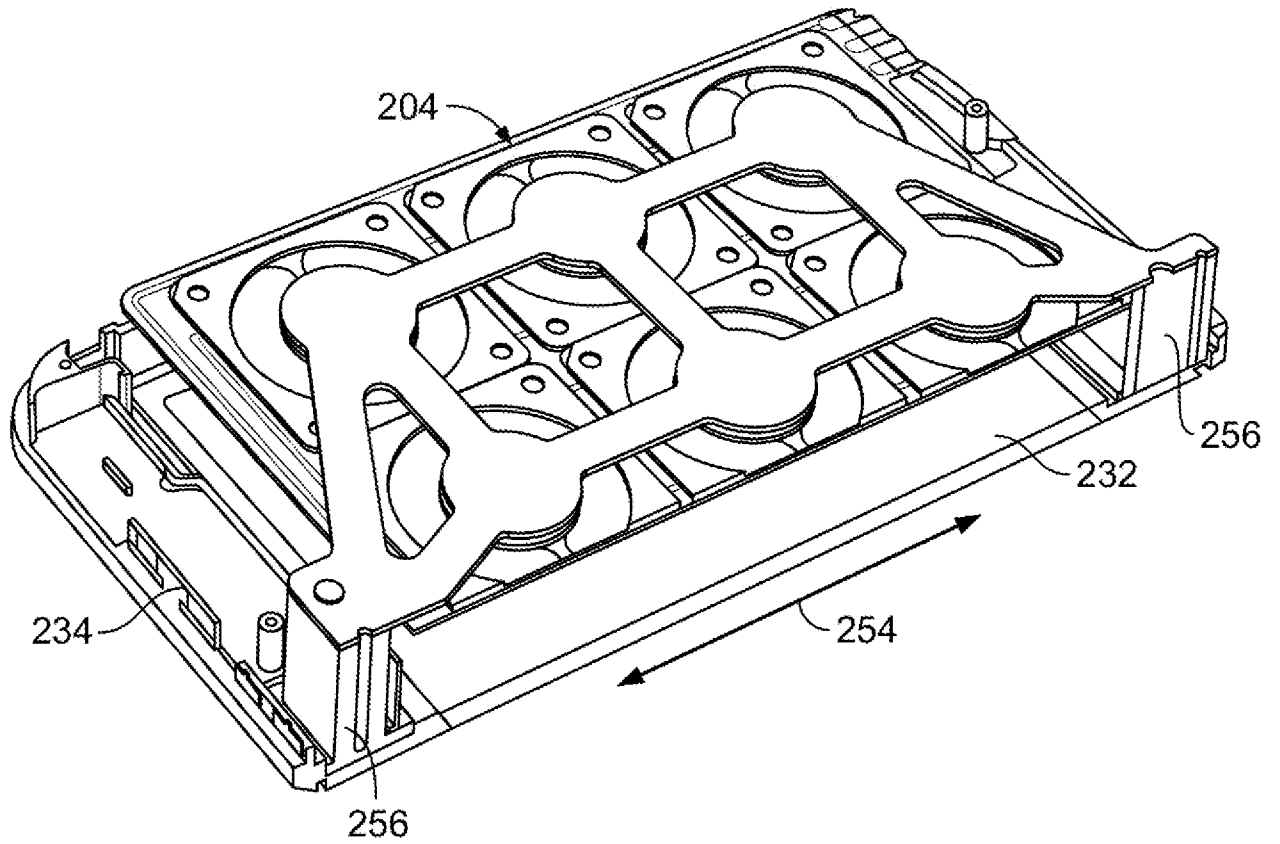

FIG. 14B

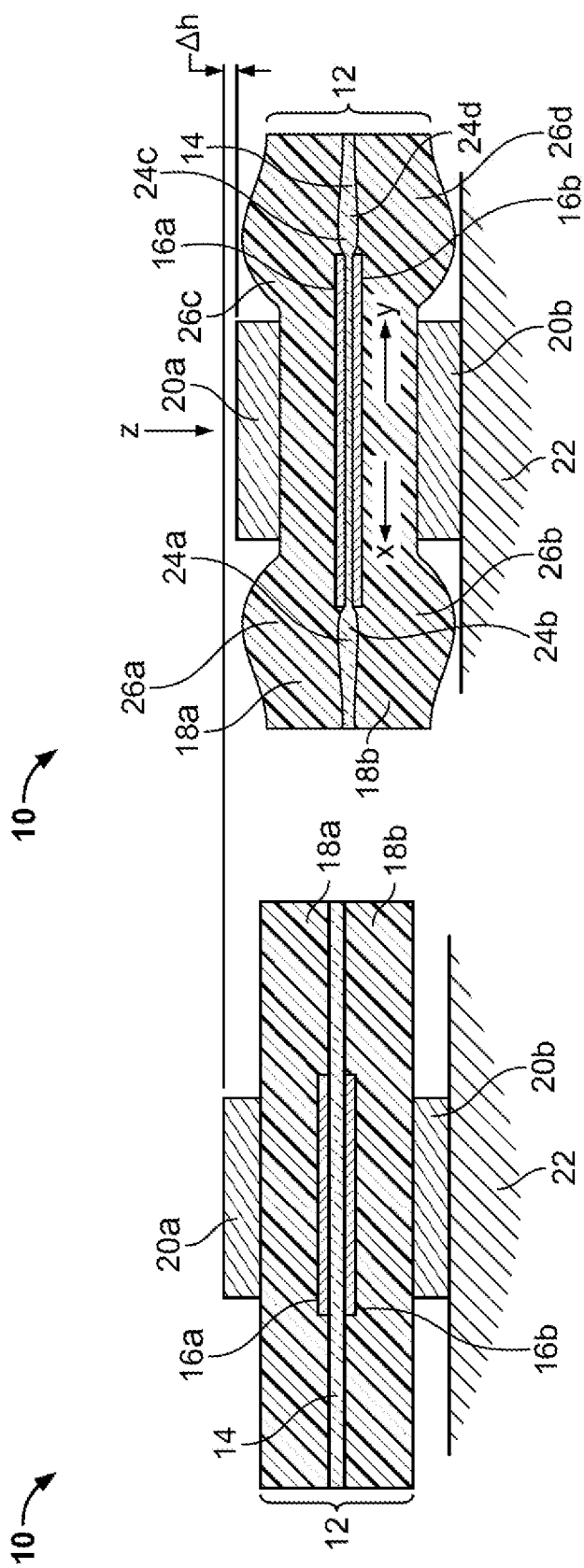

FIG. 15B

FIG. 15A

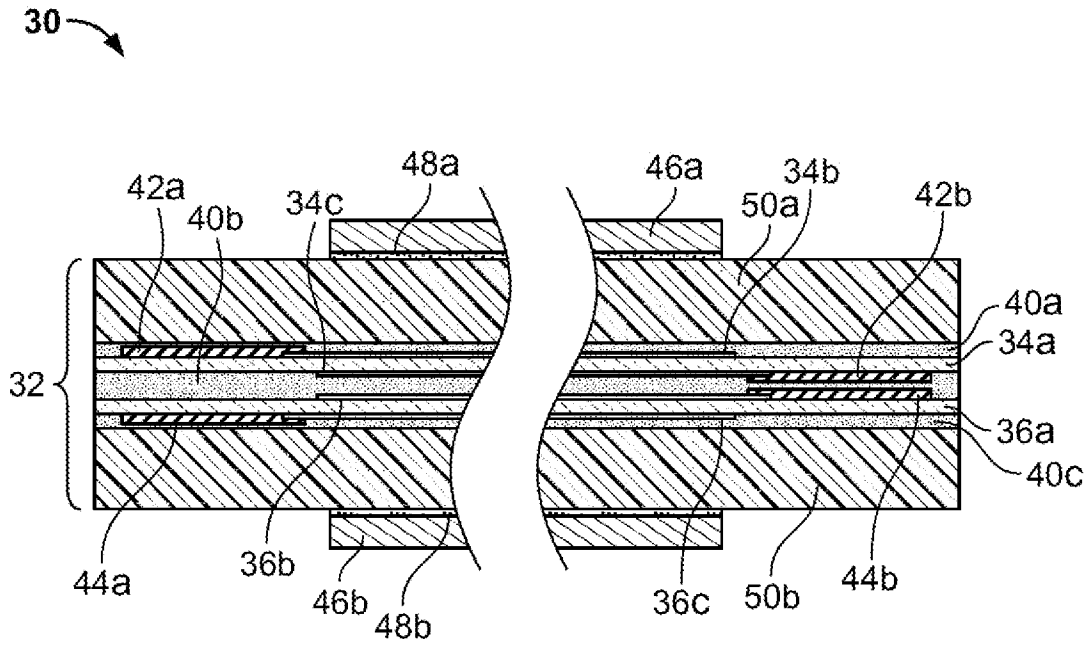

FIG. 16A

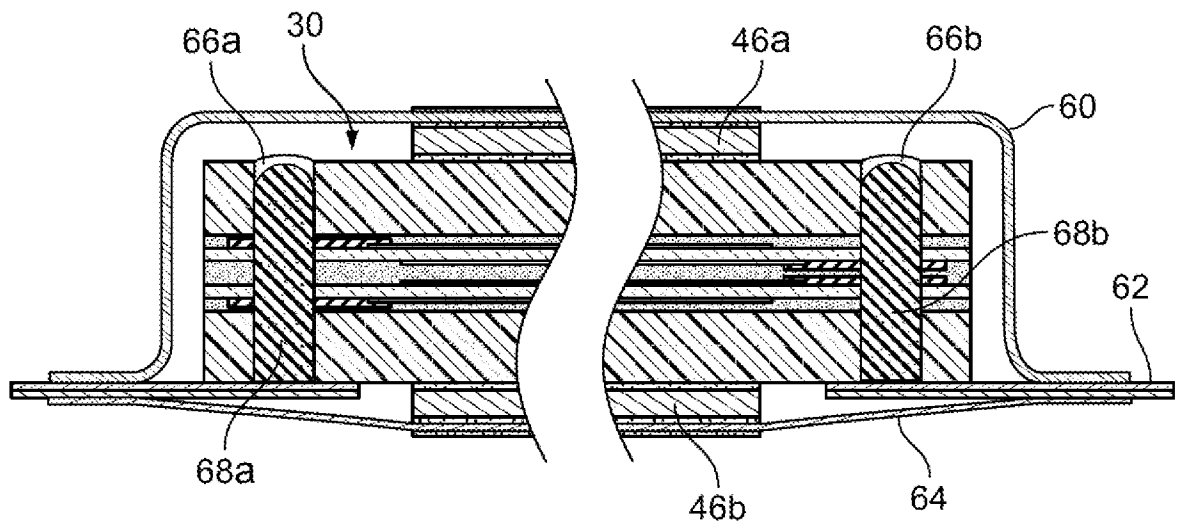

FIG. 16B

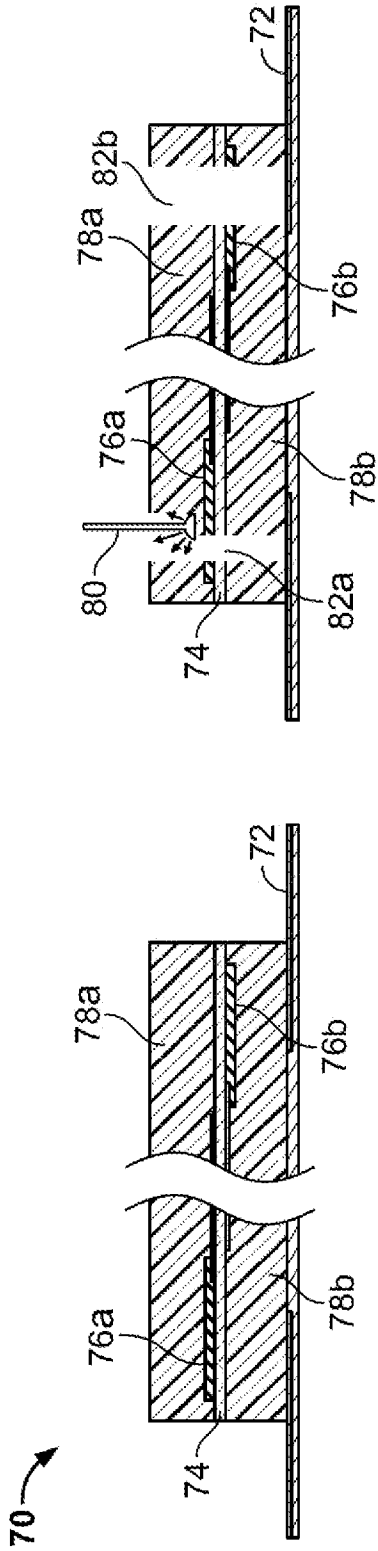

FIG. 17A

FIG. 17B

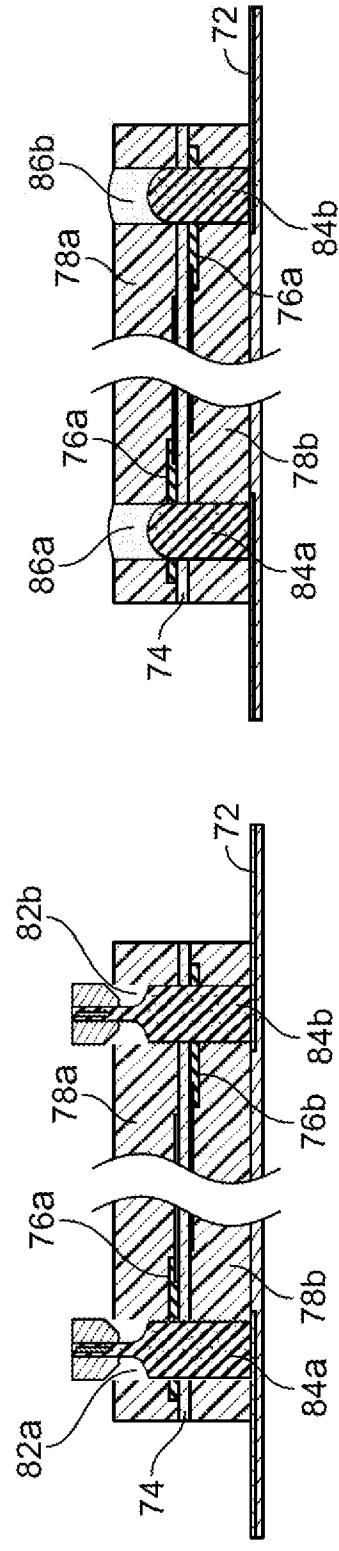

FIG. 17C

FIG. 17D

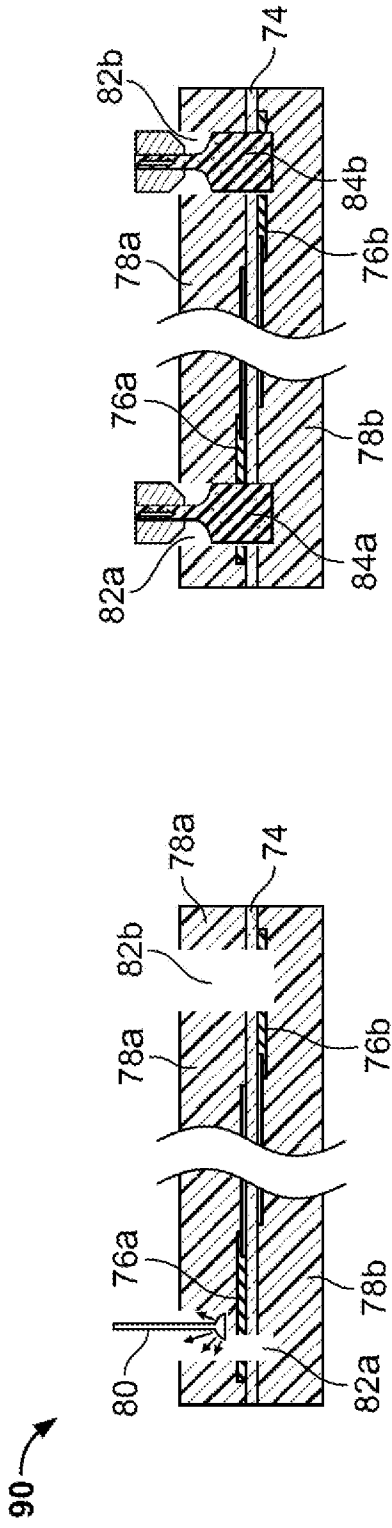

FIG. 18A

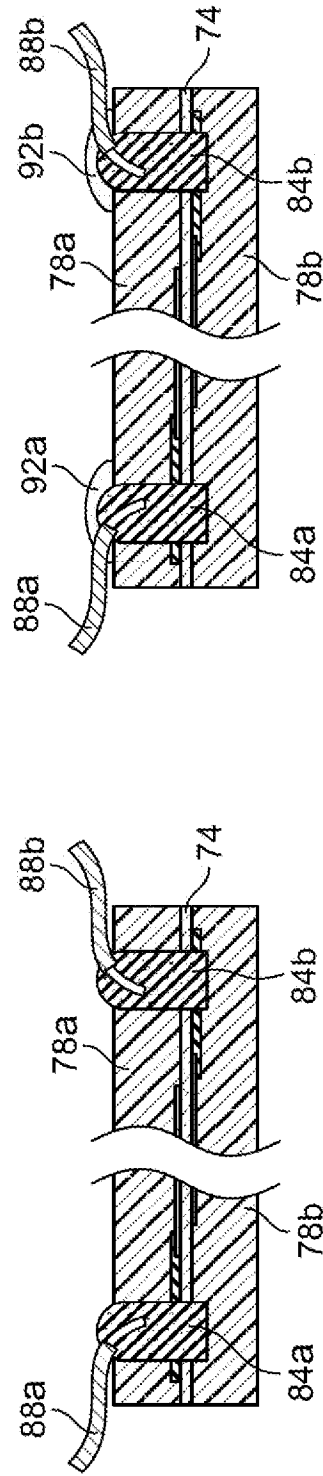

FIG. 18B

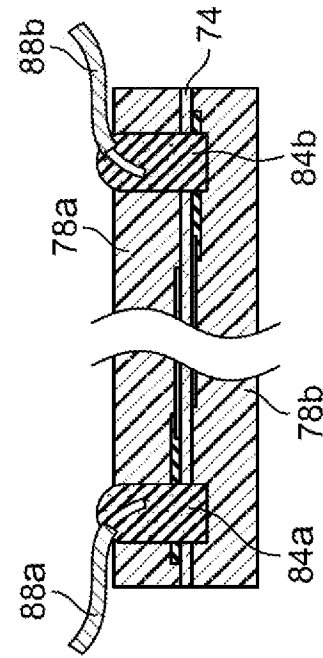

FIG. 18C

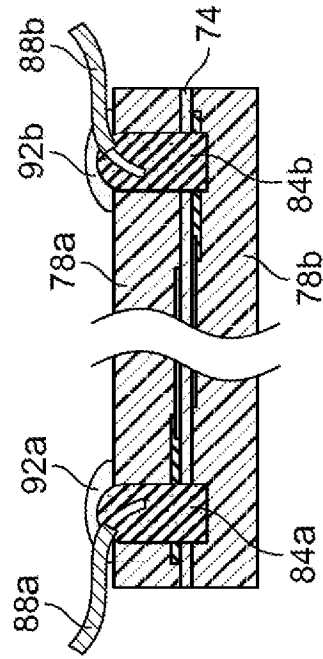

FIG. 18D

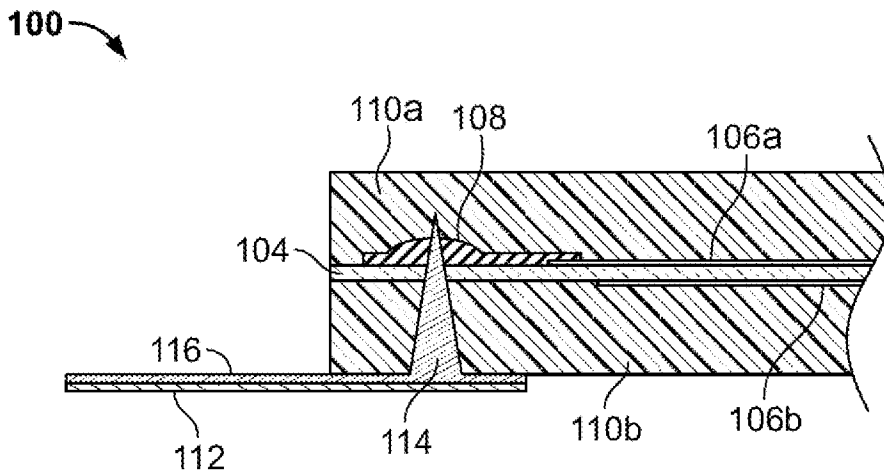

FIG. 19

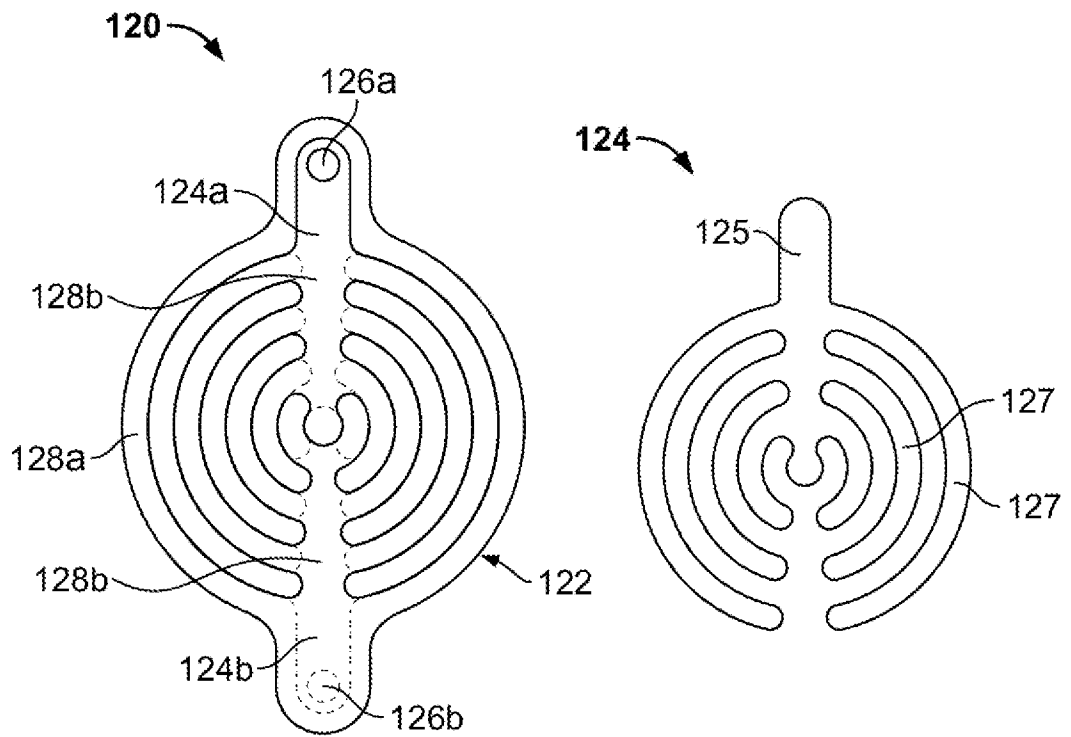

FIG. 20A

FIG. 20B

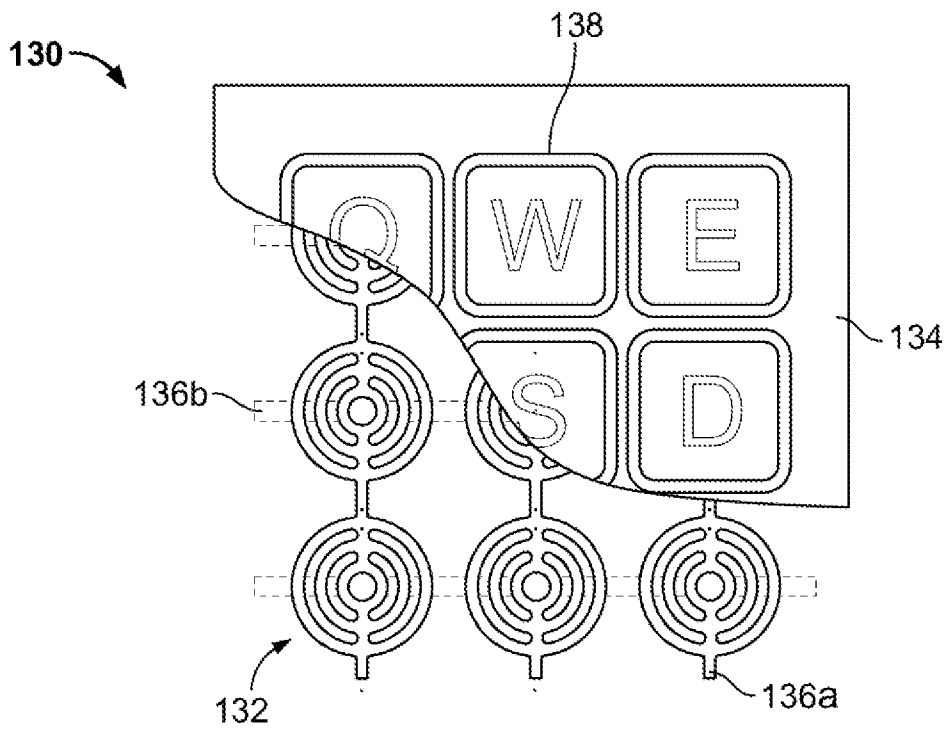

FIG. 21

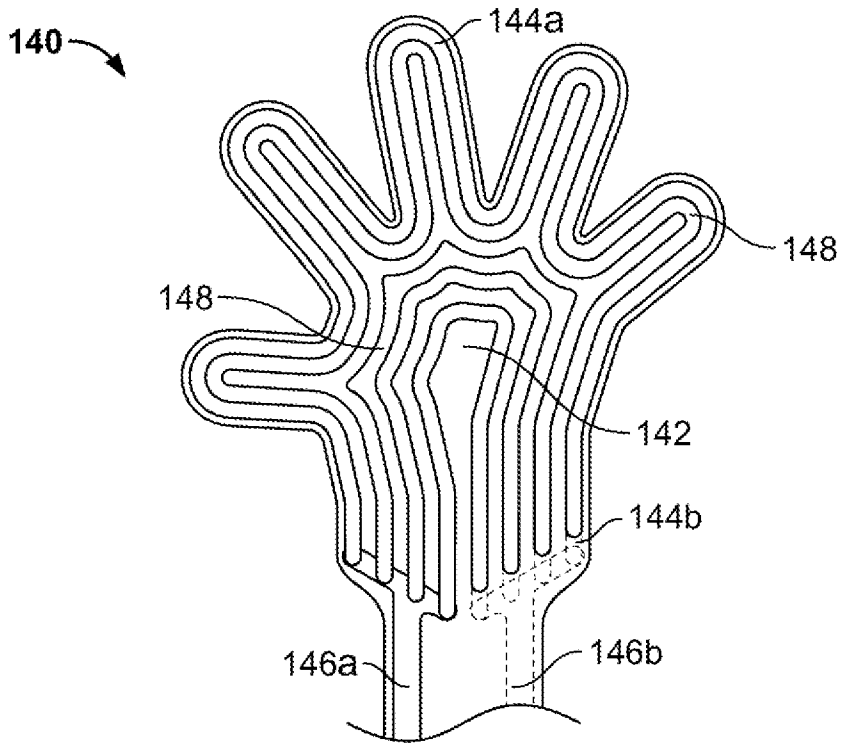

FIG. 22

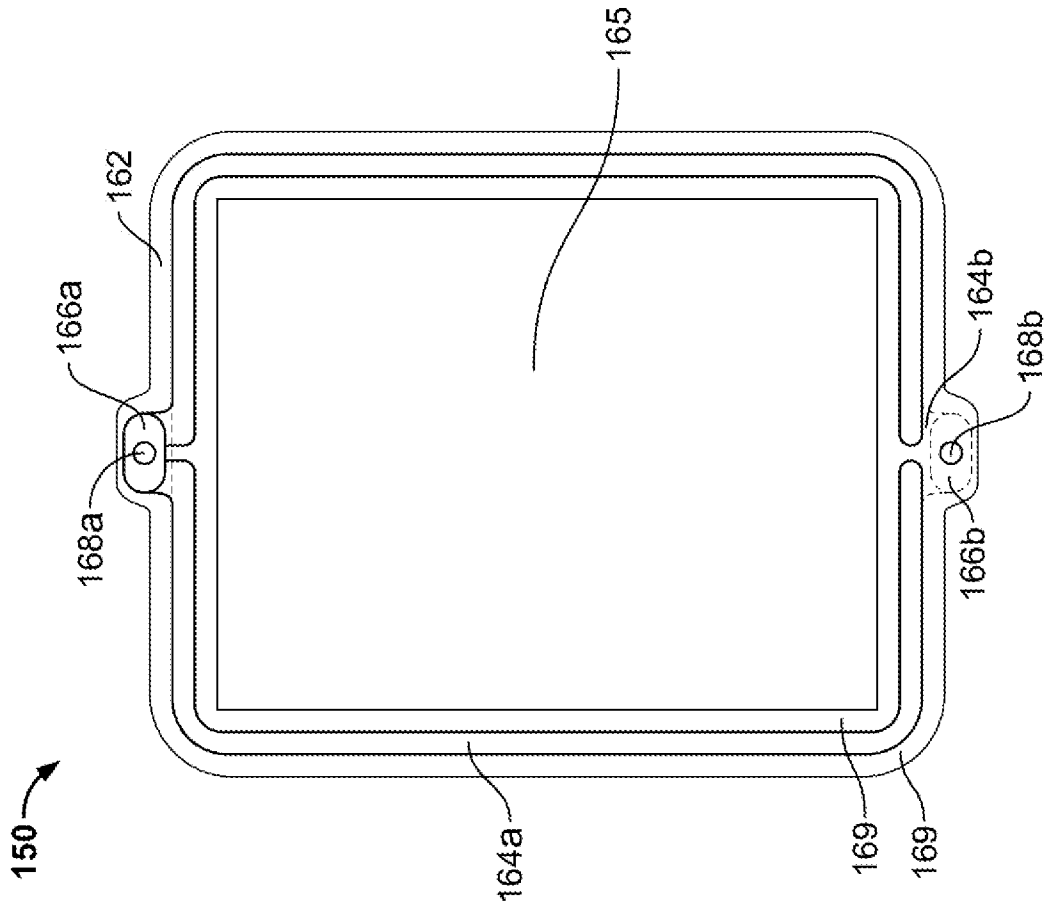

FIG. 24

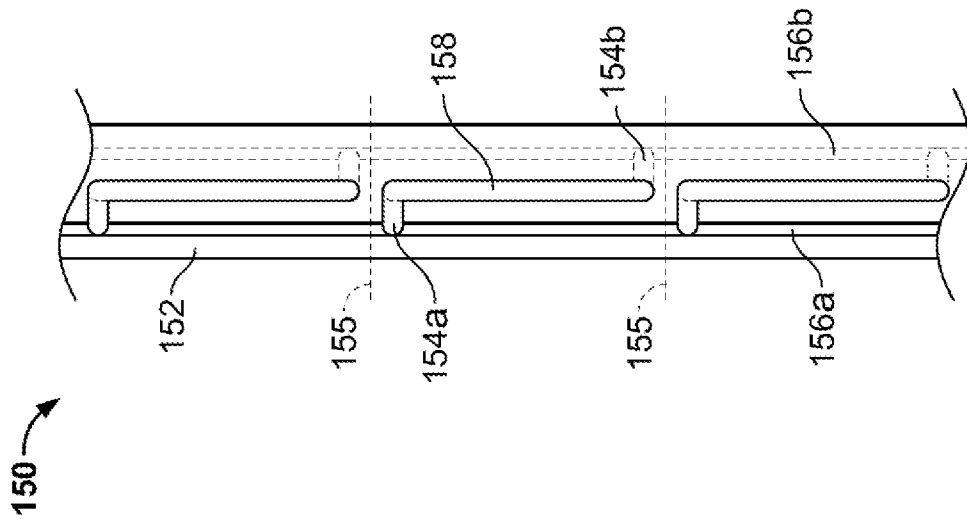

FIG. 23

23/30

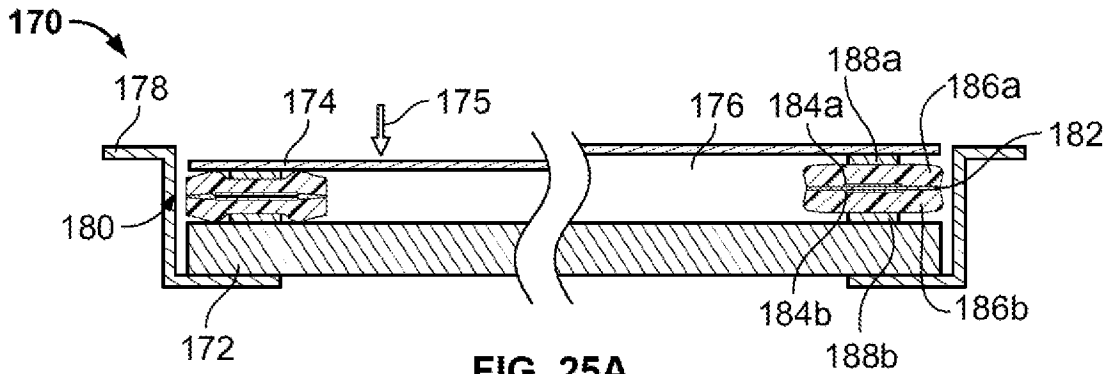

FIG. 25A

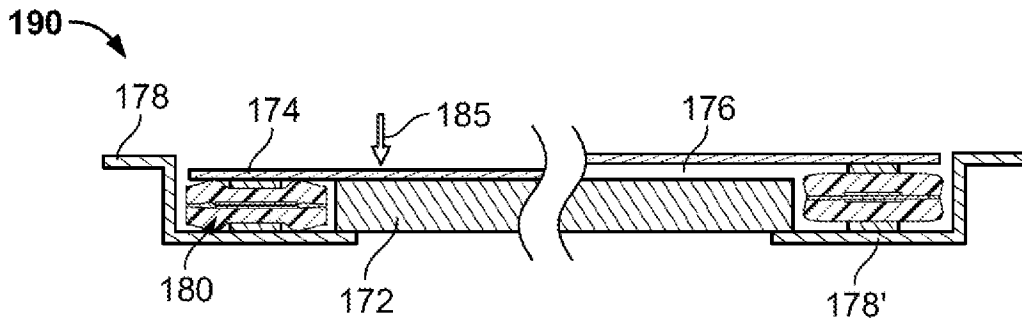

FIG. 25B

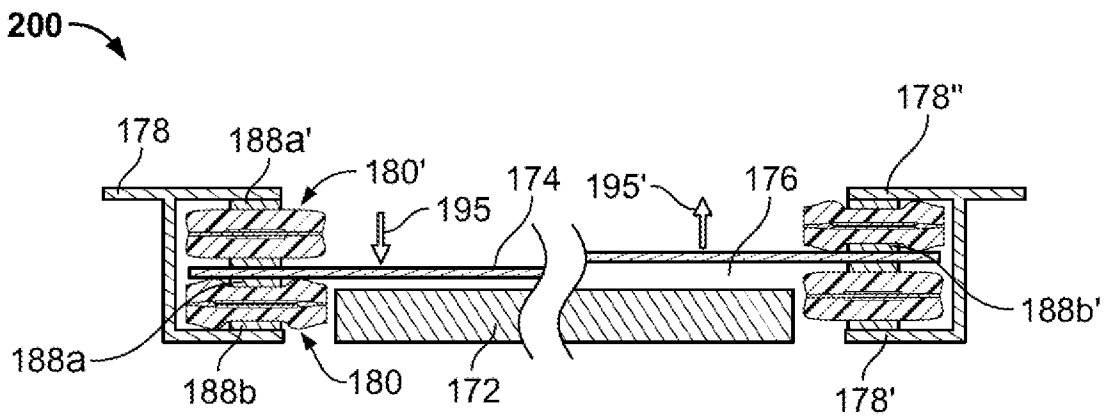

FIG. 25C

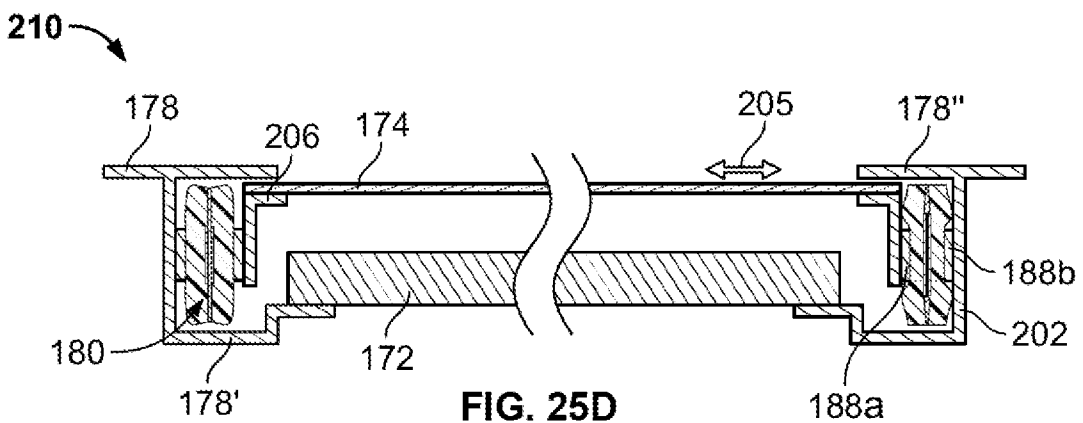
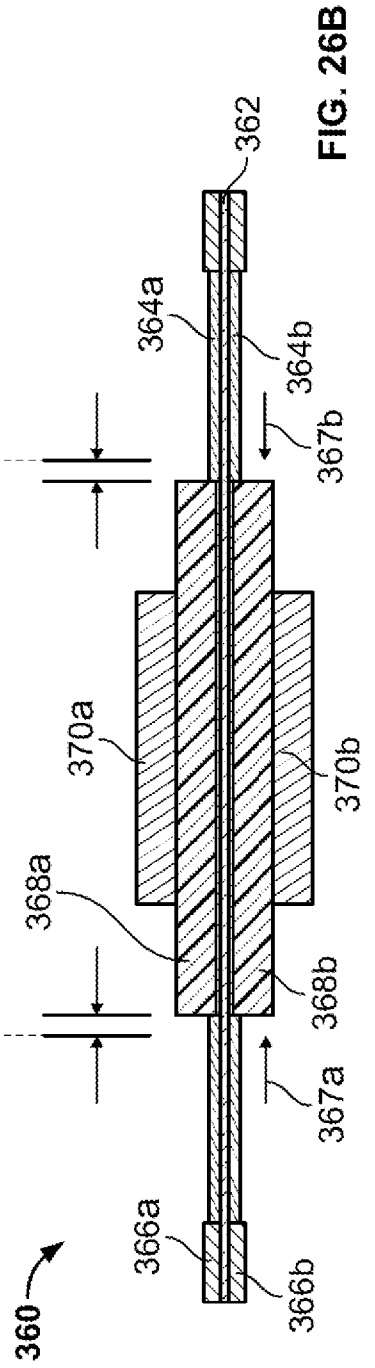
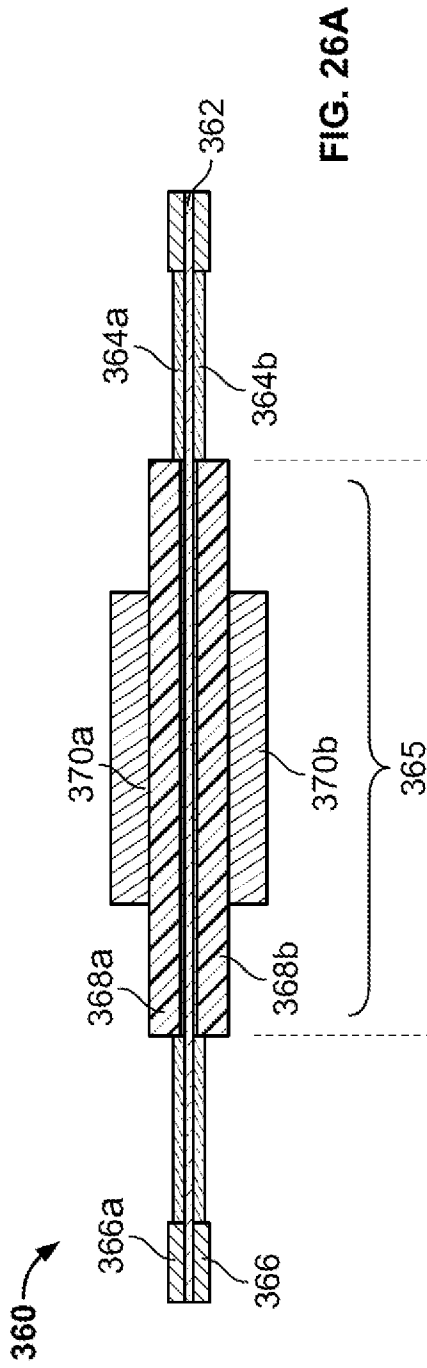

FIG. 25D



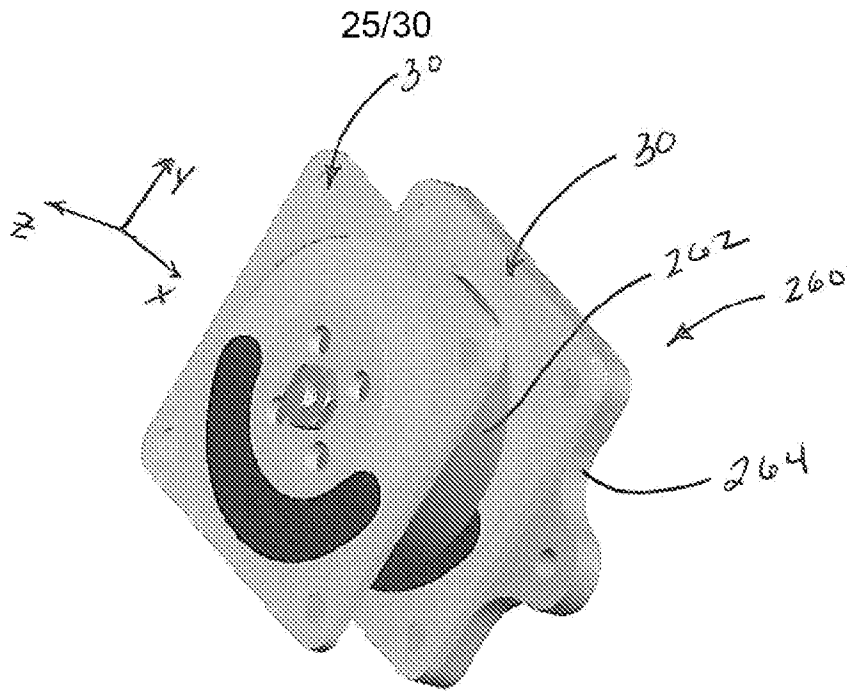

Fig 27A

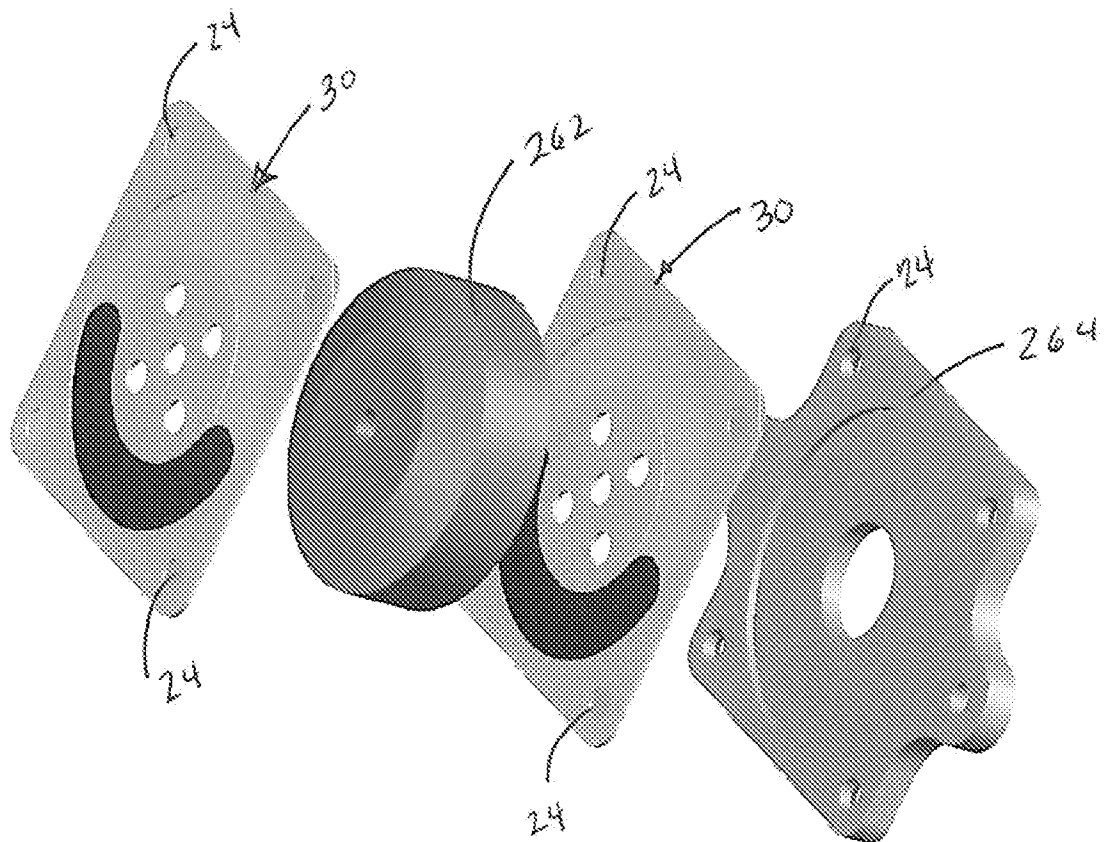

Fig 27B

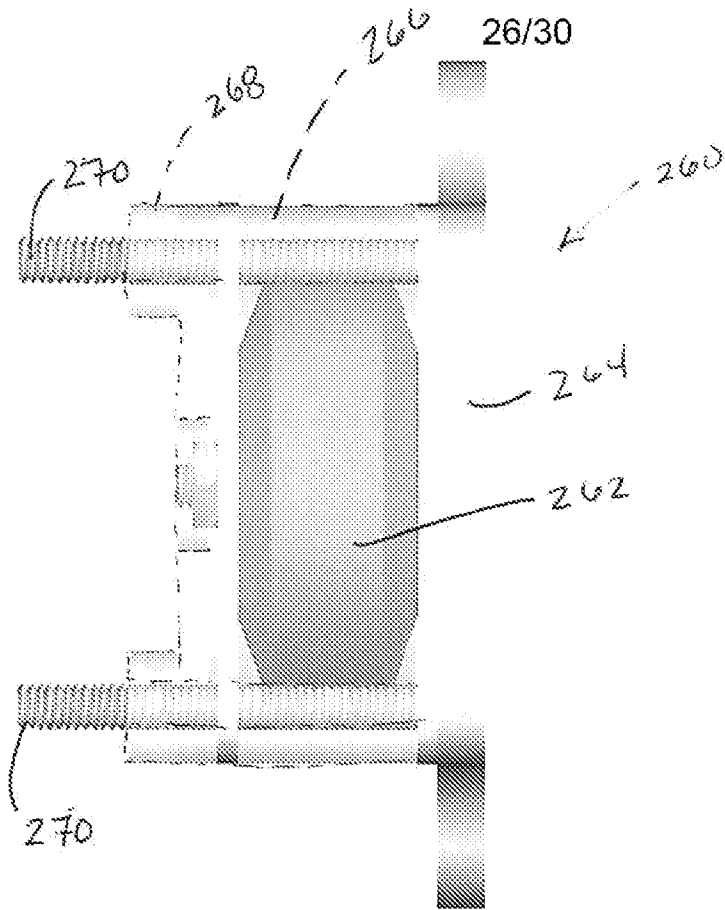

Fig 27C

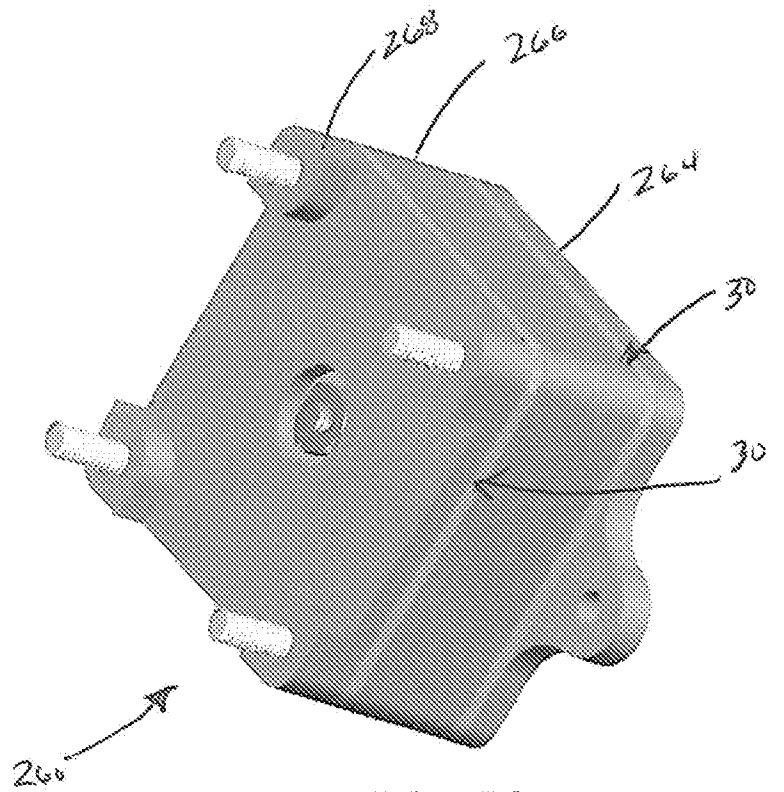

Fig 27D

27/30

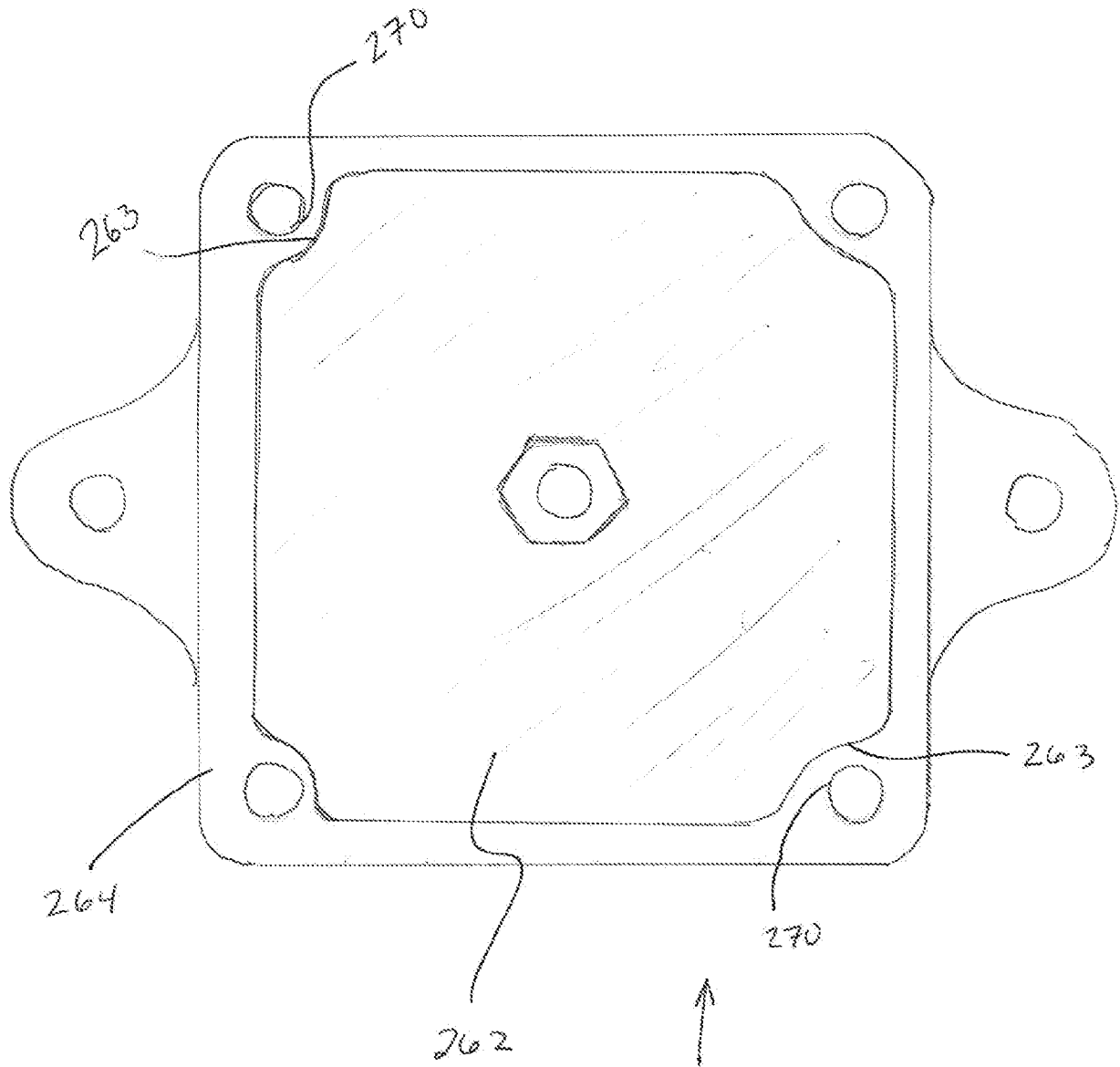

Fig 27E

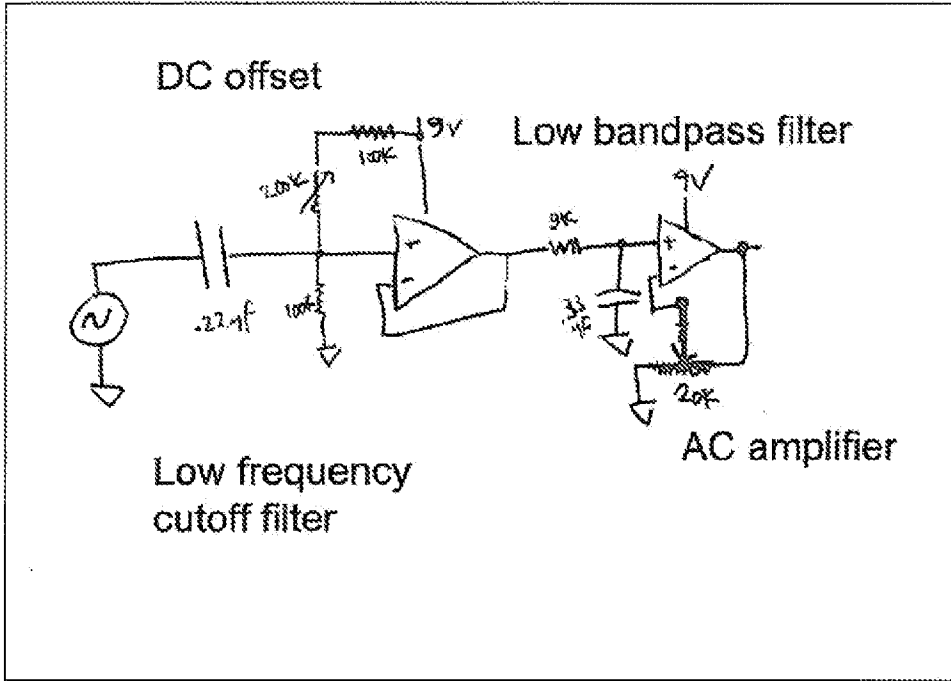

Fig 28A

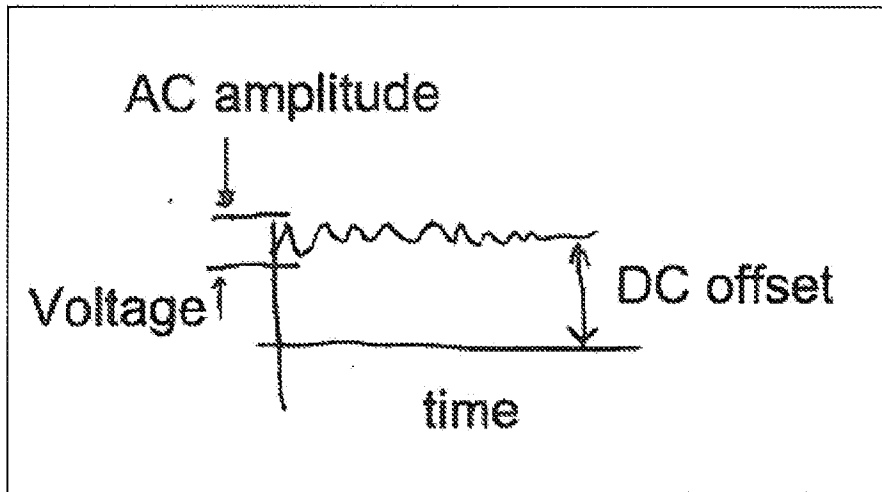

Fig 28B

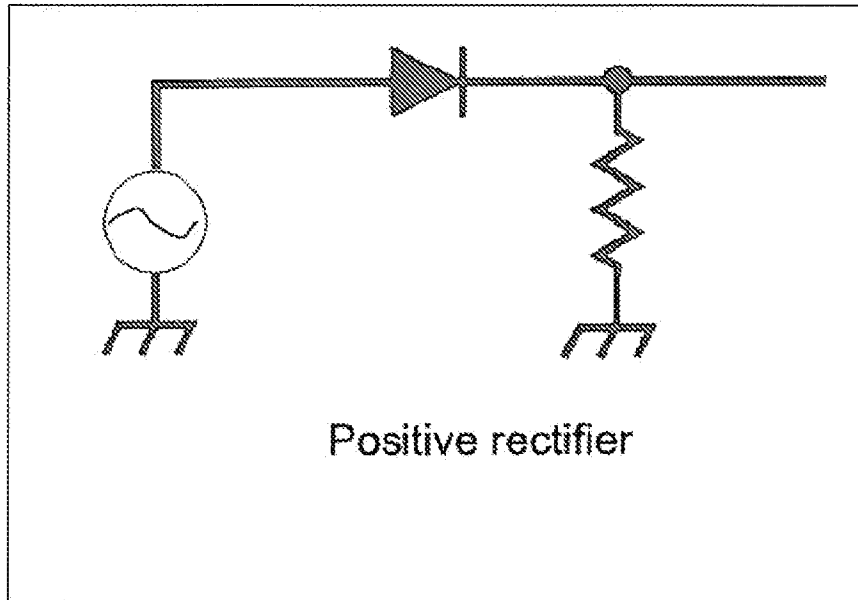

Fig 28C

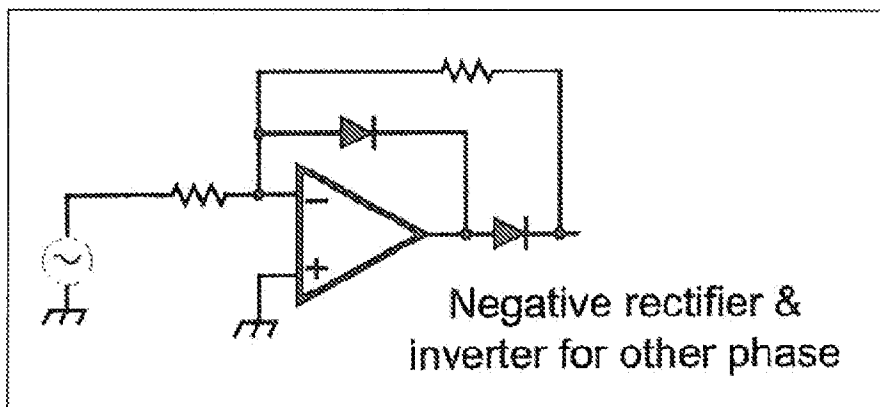

Fig 28D

30/30

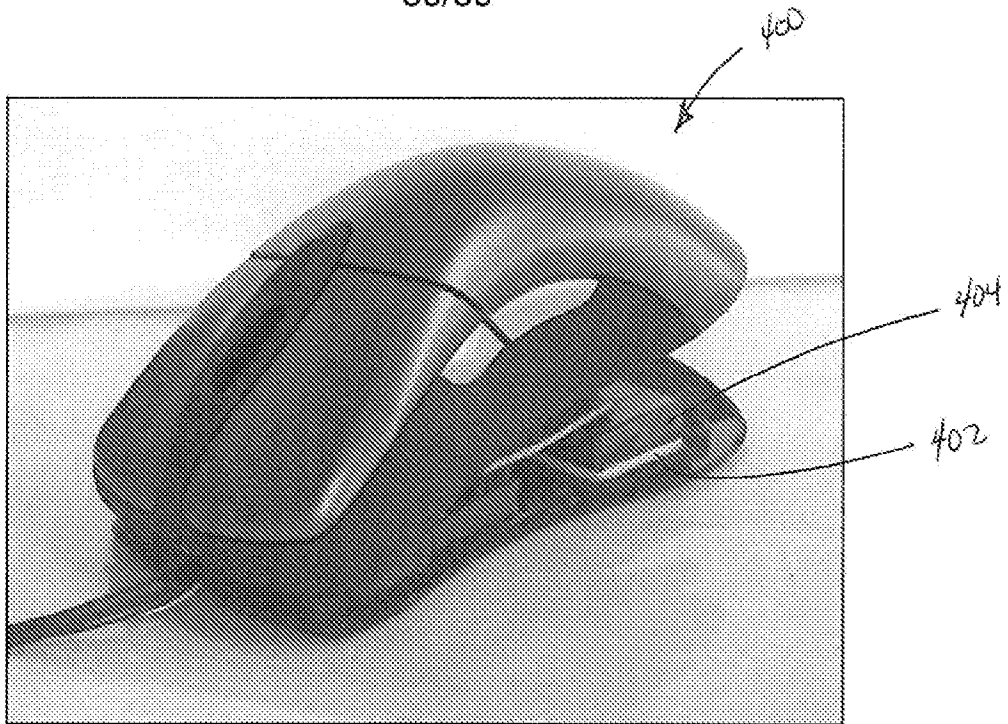

Fig 28E

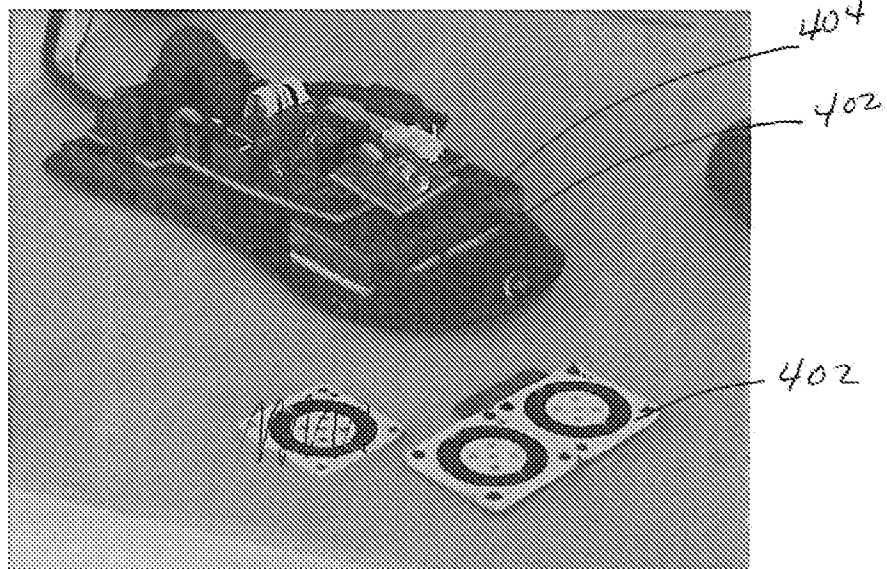

Fig 28F

INTERNATIONAL SEARCH REPORT

International application No.

PCT/US 09/63307

A. CLASSIFICATION OF SUBJECT MATTER

IPC(8) - G06F 3/041 (2009.01)

USPC - 345/173

According to International Patent Classification (IPC) or to both national classification and IPC

B. FIELDS SEARCHED

Minimum documentation searched (classification system followed by classification symbols)

IPC(8): G06F 3/041 (2009.01)

USPC: 345/173

Documentation searched other than minimum documentation to the extent that such documents are included in the fields searched
USPC: 345/156, 173; 381/111, 191; 715/702 (view text search terms below)Electronic data base consulted during the international search (name of data base and, where practicable, search terms used)
pubWEST(PGPB,USPT,EPAB,JPAB; PLUR=YES); Google Scholar; FreePatentsOnline; Text search terms: electroactive EAP polymer haptic tactile sensory feedback audio sound voice music noise sound-effect displace film layer surface thin-film thickness plane exposed unprotected uncovered not-covered open stacked piled layered aligned...

C. DOCUMENTS CONSIDERED TO BE RELEVANT

Category*	Citation of document, with indication, where appropriate, of the relevant passages	Relevant to claim No.
Y	WO 2006/121818 A2 (ALVAREZ ICAZA RIVERA et al.) 16 November 2006 (16.11.2006) entire document, especially Abstract; Figs. 1A, 1B, 1C, 3M, 4G, 9E, 8J; para [0057], [0064]-[0066], [0109], [0119], [0129]-[0130], [0144], [0165], [0170]-[0171], [0189], [0191], [0201], [0216], [0222], [0224], [0227], [0235], [0253], [0258], [0262], [0266], [0274], [0278], [0301], [0308], [0319]	1-28
Y	US 2005/0192727 A1 (SHOSTAK et al.) 01 September 2005 (01.09.2005) entire document, especially Abstract; Fig. 108; para [0321], [0867], [0888], [1160], [1284], [1542], [1700], [1715], [1723], [2035], [2121]	1-15, 27
Y	US 2004/0230090 A1 (HEGDE et al.) 18 November 2004 (18.11.2004) entire document, especially Abstract; Figs. 19A-19B, 49A-49B; para [0016], [0149]-[0150], [0154], [0166], [0171], [0187], [0232]	16-28
A	US 2005/0215764 A1 (TUSZYNSKI et al.) 29 September 2005 (29.09.2005) entire document	1-28

 Further documents are listed in the continuation of Box C.

* Special categories of cited documents:	"T" later document published after the international filing date or priority date and not in conflict with the application but cited to understand the principle or theory underlying the invention
"A" document defining the general state of the art which is not considered to be of particular relevance	"X" document of particular relevance; the claimed invention cannot be considered novel or cannot be considered to involve an inventive step when the document is taken alone
"E" earlier application or patent but published on or after the international filing date	"Y" document of particular relevance; the claimed invention cannot be considered to involve an inventive step when the document is combined with one or more other such documents, such combination being obvious to a person skilled in the art
"L" document which may throw doubts on priority claim(s) or which is cited to establish the publication date of another citation or other special reason (as specified)	"&" document member of the same patent family
"O" document referring to an oral disclosure, use, exhibition or other means	
"P" document published prior to the international filing date but later than the priority date claimed	

Date of the actual completion of the international search

16 December 2009 (16.12.2009)

Date of mailing of the international search report

30 DEC 2009

Name and mailing address of the ISA/US
Mail Stop PCT, Attn: ISA/US, Commissioner for Patents
P.O. Box 1450, Alexandria, Virginia 22313-1450
Facsimile No. 571-273-3201Authorized officer:
Lee W. YoungPCT Helpdesk: 571-272-4300
PCT OSP: 571-272-7774