

(19) World Intellectual Property
Organization
International Bureau



(43) International Publication Date
3 March 2005 (03.03.2005)

PCT

(10) International Publication Number
WO 2005/019729 A2

- (51) International Patent Classification⁷: **F23Q**
- (21) International Application Number:
PCT/US2004/026762
- (22) International Filing Date: 19 August 2004 (19.08.2004)
- (25) Filing Language: English
- (26) Publication Language: English
- (30) Priority Data:
60/496,494 20 August 2003 (20.08.2003) US
60/538,021 21 January 2004 (21.01.2004) US
- (71) Applicant (for all designated States except US):
WILLIAMS FIRE AND HAZARD CONTROL, INC. [US/US]; P.O. BOX 1359, Mauriceville, TX 77626 (US).
- (72) Inventor; and
(75) Inventor/Applicant (for US only): **DWIGHT, P., Williams** [US/US]; 1530 Texla Road, Vidor, TX 77662 (US).
- (74) Agent: **SHAPER, Sue, Z.**; 1800 West Loop South, Suite 750, Houston, TX 77027 (US).
- (81) Designated States (unless otherwise indicated, for every kind of national protection available): AE, AG, AL, AM, AT, AU, AZ, BA, BB, BG, BR, BW, BY, BZ, CA, CH, CN, CO, CR, CU, CZ, DE, DK, DM, DZ, EC, EE, EG, ES, FI, GB, GD, GE, GH, GM, HR, HU, ID, IL, IN, IS, JP, KE, KG, KP, KR, KZ, LC, LK, LR, LS, LT, LU, LV, MA, MD, MG, MK, MN, MW, MX, MZ, NA, NI, NO, NZ, OM, PG, PH, PL, PT, RO, RU, SC, SD, SE, SG, SK, SL, SY, TJ, TM, TN, TR, TT, TZ, UA, UG, US, UZ, VC, VN, YU, ZA, ZM, ZW.
- (84) Designated States (unless otherwise indicated, for every kind of regional protection available): ARIPO (BW, GH, GM, KE, LS, MW, MZ, NA, SD, SL, SZ, TZ, UG, ZM, ZW), Eurasian (AM, AZ, BY, KG, KZ, MD, RU, TJ, TM), European (AT, BE, BG, CH, CY, CZ, DE, DK, EE, ES, FI, FR, GB, GR, HU, IE, IT, LU, MC, NL, PL, PT, RO, SE, SI, SK, TR), OAPI (BF, BJ, CF, CG, CI, CM, GA, GN, GQ, GW, ML, MR, NE, SN, TD, TG).
- Published:
— without international search report and to be republished upon receipt of that report
- For two-letter codes and other abbreviations, refer to the "Guidance Notes on Codes and Abbreviations" appearing at the beginning of each regular issue of the PCT Gazette.

(54) Title: DRY CHEMICAL SYSTEM FOR EXTINGUISHING DIFFICULT FUEL OR FLAMMABLE LIQUID FIRES IN AN INDUSTRIAL TANK WITH A ROOF CREATING A SPACE ABOVE THE LIQUID

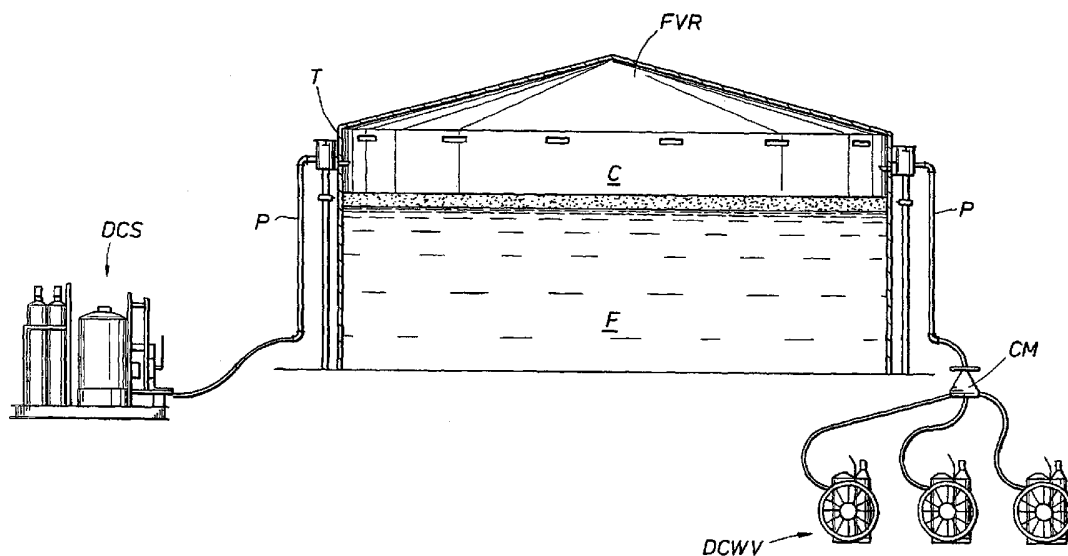

(57) Abstract: A system and apparatus for extinguishing a fire of a difficult to extinguish fuel or flammable liquid in a storage tank fitted with at least a significant top roof portion, the system including timely discharge of dry powder into a significantly enclosed space or cavity defined between the fuel/liquid surface, or between any floater remaining thereon, and the fixed top roof portion, and apparatus to facilitate the system.

WO 2005/019729 A2

Title: Dry Chemical System for Extinguishing Difficult Fuel or Flammable Liquid Fires in an Industrial Tank with a Roof Creating a Space Above the Liquid

Inventor: Dwight P. Williams

5

FIELD OF THE INVENTION

The instant invention relates to a dry chemical system for extinguishing a difficult fuel or flammable liquid fire in an industrial scale storage tank having a roof creating a space above the liquid, typically a fixed roof on top of the tank.

10

BACKGROUND OF THE INVENTION

Industrial fuel and/or flammable liquid storage tanks frequently have a roof creating a space above the liquid, usually a fixed conically- or geodesically-shaped roof welded to the top of the tank. Such tanks may have a double roof, including an internal floating roof, called a floater, designed to float on top of the fuel/liquid with seals for sealing against the inside tank wall. The fixed cone or geodesic top roof is typically attached by welding. A roof system comprised of either a single fixed top portion or of two portions, a fixed top and a floater, creates and defines a space or cavity between either the surface of the fuel/liquid and/or the floater below and the top roof above.

Vents are typically provided to vent to the atmosphere vapors that collect in the space or cavity between the fuel/liquid (or floater) and a top fixed roof. The usual vents are "eyebrow vents", comprising spaced rectangular openings around a top portion of the vertical tank wall, and/or roof vents, comprising spaced openings around the periphery of the top roof. Each vent typically has a covering of some type.

In the event of a fire in the fuel or flammable liquid tank having a fixed top roof, it is industry standard procedure, regulated by the NFPA, to extinguish the fire (or at least to attempt to do so) by a foam attack, the attack comprising laying a foam blanket on the fuel/liquid surface, typically by discharging foam into the space or cavity between a fixed top roof and the liquid surface and/or a floater. It should be understood that the fire may, at least initially, occur only at the vents, where the fuel/liquid vapors meet atmospheric air. The vapor mixture in the cavity, at least initially, may be too rich to burn. NFPA has guidelines for the rate of foam application and the duration of a foam attack, adjusted for different type fuels or flammable liquids, different foams and different tanks, in

order to achieve extinguishment.

Recent discoveries by the instant inventor while extinguishing a blended fuel tank fire in Guatemala, revealed that foam alone may not extinguish a difficult fuel or flammable liquid fire in a storage tank having a fixed top roof, even when foam is placed in the cavity
5 in accordance with NFPA recommended procedures, rates and durations. This appears disturbingly true of the new blended fuels having a high-octane content. It is a disconcerting discovery. Foam alone may not extinguish the fire at all, and quite likely will not do so per current NFPA regulations or guidelines.

The instant invention teaches, therefore, an improved system designed to cost
10 effectively extinguish a "difficult fire" in a tank with a fixed roof, or a roof that creates a space between the roof and the liquid. The improved system is designed in particular to cost effectively extinguish a fire of a difficult to extinguish fuel or flammable liquid having a high-octane content. The invention teaches a staged and timed discharge of dry chemical into the space between the burning fuel/liquid and the roof. The timing of the staging of
15 the discharge of the dry chemical is selected to follow a pertinent period of foam application. Dry chemical is a limited and rationed resource. Discharging the dry chemical too soon might be ineffective and, thus, waste the resource.

The discharging of the dry chemical can be effected by one of several means or techniques, using portable and/or fixed systems. (A "fixed system" is equipment put in
20 place prior to a fire, fixed prior to an emergency, in anticipation of emergencies. In contrast, portable systems are brought to the locale of the emergency upon notice.) Vents provided to vent vapors that collect under a roof can be advantageously used as an entry means to discharge the dry chemical into the space above the fuel/liquid and below the roof. Both portable and fixed systems could utilize such existing vents. Alternately special
25 vents for fixed foam systems can be utilized for a fixed dry chemical system.

It is the inventor's experience and observation that dry chemicals, timely inserted into the space between burning fuel/liquid and the roof, after substantial foam attack, chase any remaining persistent, pernicious fire or vagrant flames in the cavity and serve to completely extinguish the fire. Foam alone is an inferior more costly means, if not a totally
30 inadequate means, to completely extinguish residual flames in such a tank. Foam is expensive. The extra time required to secure extinguishment, even if it can be achieved, with a continued application of foam alone as compared to the instant invention, is

unnecessarily costly.

The instant staged dry chemical methodology and apparatus for extinguishing a “fixed roof” (so to speak) tank fire may be implemented in various forms, including using portable apparatus and/or fixed systems. Fixed systems and/or special portable apparatus could be less risky for firefighters, and as such would be preferred over a portable embodiment requiring firefighters to climb the tank, walk over the roof and insert dry chemical through an existing or created vent or opportune opening with a hand held nozzle.

The term “difficult to extinguish fuel or flammable liquid” or “difficult fuel or flammable liquid fires” is used herein to refer to fluid fuels or flammable liquids that are, at least, in substantial part, low-surface tension fuels/liquids and/or high-vapor pressure fuels/liquids and/or octane-boosted fuels/liquids and/or oxygenated fuels/liquids. The implied comparison in these instances would be recognized by one of skill in the art to be with the historic straight chain fuels or flammable liquids of the mid-20th century.

It should be understood that although a tank may be designed with, and originally exist with, a particular roof system, the initiation of a fire or hazard may have altered or destroyed part or all of the original roof system. Thus, the characterization of a storage tank may have to be reassessed. Original floating roofs, or floating roof portions, may have tilted or partially sunk or totally sunk. Seals may have been destroyed, in whole or in part. Fixed roofs may have been blown awry, or may have been partially dislodged or tilted, or at least their connections, such as a welded connection with a tank wall, may have been partially or totally destroyed. The instant invention relates to a tank that, at the time of the fire, still has at least a significant roof portion creating a substantially enclosed space above the fuel/liquid and below the roof. That is, the invention relates to situations where a difficult fuel or flammable liquid is on fire and there is at least a significant roof portion above the fuel/liquid surface, defining a substantially enclosed space or cavity therebetween. Although welds may be blown off from an original fixed roof portion, and hatches and vents may be blown apart, the invention applies if there remains a significant space or cavity between a burning fuel/liquid and a roof portion. Note again: the fuel/liquid may be burning only where it secures sufficient oxygen, such as at least initially where fuel vapors meet the atmosphere at vents or other open portions.

SUMMARY OF THE INVENTION

The instant invention discloses a system for extinguishing a fire of a difficult to

extinguish fuel or flammable liquid in a storage tank having at least a roof portion that creates a substantially enclosed space above a significant portion of the liquid and below the roof, usually a tank fitted with a fixed top roof that remains substantially in place. The invention includes creating a foam blanket on the fuel/liquid surface, such as by discharging
5 foam into a cavity above the fuel/liquid. (A foam blanket should be understood to include foam and/or film.) Preferably, after covering at least 90% of the liquid surface with a foam blanket and/or after establishing a foam blanket for a significant period of time under the circumstances, such that at least a minimal blanket of foam is created under the circumstances, most preferably after at least two-thirds of a NFPA recommended
10 application rate/duration procedure guideline for the foam attack, then discharging dry chemical into a cavity above the foam blanket and below a roof portion. Preferably the dry chemical would be discharged during the last ten minutes of a NFPA recommended application rate/duration procedure guideline for a foam attack. Dry chemical would typically be discharged for a period of five to fifteen seconds. Existing vapor vents offer
15 fortuitous openings for discharging the dry chemical into the cavity between the fuel/liquid and the roof using portable or fixed dry chemical systems. Preferably a dry chemical fixed system could be already in place, having conduits and a nozzle ready to be connected to dry chemical sources, such as wheeled units or a dry chemical skid, and having a discharge orifice or nozzle in the cavity.

20 Fixed apparatus for extinguishing a difficult fuel or flammable liquid fire in a storage tank having a cavity between the fuel/liquid surface and a roof portion could include at least one dry chemical supply pipe or line rising along a portion of a tank wall and having at least one end opening created in a tank vent, such as through a roof or eyebrow vent, or through a fixed foam system opening into the tank. The supply pipe could be placed in fluid
25 communication with a wheeled unit, a skid, or the like, having a source of dry powder. The supply pipe is preferably permanently affixed, but could be portable.

BRIEF DESCRIPTION OF THE DRAWINGS

A better understanding of the present invention can be obtained when the following detailed description of the preferred embodiments are considered in conjunction with the
30 following drawings, in which:

Figure 1 illustrates a tank with a fixed top roof and a floater, creating a space or cavity in between. It should be understood that if a floater were not there, the space or

cavity would be between the liquid surface and the fixed top.

Figure 2 illustrates a top view of a fixed top roof on a tank. The roof illustrates vents and portions of a dry chemical supply system.

Figure 3 illustrates a dry chemical riser pipe for a tank with a fixed roof.

5 Figure 4 illustrates an embodiment of a dry chemical discharge head for insertion inside a tank shell, preferably for insertion inside a vent.

Figure 5 illustrates a tank with a fixed roof, the tank having a fixed foam system and a fixed dry chemical system.

10 Figures 6 and 7 illustrate details of the fixed foam and dry chemical system of Figure 5.

The drawings are primarily illustrative. It would be understood that structure may have been simplified and details omitted in order to convey certain aspects of the invention. Scale may be sacrificed to clarity.

DESCRIPTION OF THE PREFERRED EMBODIMENTS

15 Figure 1 illustrates tank T having what is referred to as a composite roof system, the system comprised of a floating roof portion or floater FR and a fixed roof portion FXR. Space or cavity C is created between the floating roof portion FR and fixed roof portion FXR. Floating roof portion FR is understood to be floating on top of fuel/liquid F in tank T. It should be understood and appreciated that were there no floater, or were no floater
20 to substantially remain at the time of a fire, the space or cavity C would be created above the fuel/liquid surface and below the fixed top roof portion.

In a worst-case scenario, fuel/liquid F is a blended fuel. Blended fuels can have a high-octane content that leads to difficult extinguishment situations. Fuel/liquid F is at least a difficult fuel/liquid to extinguish.

25 Tank T in Figure 1 also illustrates portions of a fixed or portable system for application of dry chemical, comprising a ring-shaped pipe extension PE having pipe extension legs with "T"ed ends PEN. Figure 4 is a more detailed figure illustrating a pipe extension PE having "T"ed ends PEN. The "T"ed ends are structured to insert into eyebrow vents EV of tank T and to discharge therein a dry chemical, discharged inside of
30 the tank shell into cavity C.

In a typical embodiment fixed roof portion FXR is a cone roof fixed to the top of the tank wall. Geodesic-shaped fixed top roofs are also known. Floating roof portion FR

floats up and down with the surface of the fuel/liquid left in the tank T and has seals to seal against the inner tank wall.

Figure 2 illustrates a top view of a cone roof FXR having a series of roof vents RV and roof vent covers CRV. Figure 2 also illustrates portions of a fixed or portable system for application of dry chemical, including top extension TE extending up and onto cone roof FXR. In the embodiment of Figure 2 pipe or line extension PE circles cone roof FXR proximate vents RV. A portion of pipe or line extension PE extends to vents RV such that the extension is capable of discharging dry chemical through the vent into cavity C in the tank.

Figure 3 illustrates a portion of a dry chemical (fixed or portable) system including a riser pipe or supply pipe P. Preferably a tank comes equipped with a fixed riser pipe for application of dry chemical. However, a non-fixed portable dry chemical riser pipe P, or line, could be utilized. In a simple case, the pipe extension and pipe end might be no more than the end part of a straight riser pipe P. An end of such a straight dry chemical riser pipe could be inserted or wedged during a fire into an eyebrow vent.

In a situation where no fixed application system for dry chemical exists, offering preinstalled elements such as riser pipes, or pipe extensions, pipe ends and/or nozzles, the methodology can be carried out by firefighters using portable nozzles attached to supply lines. In such cases, however, a firefighter would have to approach (or to create) appropriate vents or openings on the tank or on the roof, proximate a cavity, in order to insert a dry chemical nozzle through the vent or opening.

The methodology for extinguishing a difficult fire in a tank with a fixed roof portion includes an initial foam attack wherein a foam blanket is created. (Again, foam includes film.) Preferably foam is inserted into a cavity between a floating bottom roof portion and/or the fuel/liquid surface and a top roof portion to establish and create a foam blanket. Foam should be inserted or placed in the cavity until the fuel/liquid surface is substantially covered and the fire is substantially abated. Substantial abatement of the fire can be determined to have occurred in most cases when a foam blanket has been laid upon the surface of the fuel/liquid and/or floating roof in accordance with present NFPA guidelines for the foam, fuel/liquid and tank. The period of time this takes varies depending upon the type of foam used, the capacity for discharging foam, the size and complexity of the tank and the nature of the fuel/liquid it contains. Forty-five minutes represents a typical

regulatorily approved time period for launching and sustaining a foam attack in a cavity between a floating roof and a top roof. In a preferred embodiment, sometime during the last ten minutes of any such foam attack, dry chemical would be inserted through one or more vents, or other available tank openings, into the cavity. If safer or more remotely
5 activatable means are not available, the dry chemical attack can be implemented by a firefighter carrying a hand held nozzle, attached to a line and source of dry chemical, up to a suitable opening into the cavity. A ten second application of dry chemical offers a reasonable expectation for extinguishing the remnants of the fire, the vagrant remaining flames associated with the difficult fire, especially those associated with the new blended
10 fuels. It is the experience of the instant inventor that dry chemical timely inserted into such cavities in the above situation appears to "chase" the remaining fire within the cavity and to extinguish it. Without such dry chemical treatment, for difficult fuels maintenance of a foam blanket may have to be extended for two or three times the present regulatorily set time periods, incurring considerable unanticipated expense. Indeed, there is no guarantee
15 or experience conclusively showing that foam alone can extinguish a fire of a difficult flammable liquid in a tank under a fixed roof.

Dry chemical is a relatively scarce commodity at a fire. The usage of dry chemical is carefully marshaled. Limitations on the supply of dry chemical make discharging dry
20 chemical, even for a period of minutes, essentially unfeasible or impossible. Hence, dry chemical, if it is to be utilized, must be utilized judiciously. As a resource, compared to water and/or foam, in almost all circumstances its availability for use must be considered to be quite limited. Thus, a dry chemical attack is not preferred to be commenced until at least after two-thirds of the time period for a standard recommended NFPA foam attack as
25 per NFPA guidelines. For example, if the foam attack should last over 55 to 60 minutes, the dry chemical attack preferably should not be begun until sometime in approximately the last 20 minutes, preferably not until sometime in the last 10 minutes. If there is no NFPA recommended application rate/duration procedure guideline for a particular foam or tank or fire in a given circumstance, the firefighter should extrapolate a reasonable guideline for the
30 situation based on existing NFPA recommendations in the closest related circumstances, and take that as the NFPA guideline for this case.

Figure 5 illustrates a tank T having a fixed roof FXR and a preferred embodiment for a fixed system for use in applying foam and dry chemical. The preferred fixed system

for use in applying foam and dry chemical includes a foam expansion chamber FC-HC and related conduits and valving attached to a tank, the apparatus modified to provide dry chemical capabilities. Chamber FC-HC is shown attached at an upper level of a wall portion of tank T and communicating with the inside of the tank through opening O. Foam chamber FC-HC is shown in this embodiment having its own opening O or port into the inside of tank T and cavity C. Fixed pipe P communicates dry chemical between a typically mobile or portable dry chemical supply system, which could comprise, for instance, dry chemical wheeled units DCWV or a typical dry chemical skid DCS brought to the emergency. Dry chemical wheeled units would typically feed into a dry chemical collection manifold CM and then through a line to fixed pipe P. Fixed pipe P channels the dry chemical through foam expansion chamber FC-HC and through opening O to a discharge orifice or nozzle inside the tank.

Figures 6 and 7 offer a side view and a plan view of foam expansion chamber FC-HC with dry chemical capabilities, as well as related conduits and valving. The foam expansion chamber provides a chamber for expansion and loss of velocity of the foam concentrate, prior to being discharged through opening O in sidewall of tank T. The foam system is fed fire extinguishing fluid comprising liquid water and foam concentrate through fluid pipe FP. The water and foam concentrate liquid passes through orifice plate OP having a small hole or orifice, creating a pressure differential there through. Orifice plate OP has a handle H and resembles a paddle. Pressure differential created over the orifice plate in line FP serves to draw in air through air vent AV shown as a mushroom vent with a screen. In the instant embodiment a check valve V is presented in the line as a vapor seal. Sufficient pressure from the water, foam concentrate and air will break the vapor seal sending the fluid into foam chamber FC. In foam chamber FC the foam will further expand and lose velocity prior to being discharged through opening O into the inside of tank T. Foam chamber FC is shown with an inspection cover or hatch CV, particularly important for inspection of the vapor seals.

In regard to the associated fixed system for the application of dry chemical, a chemical is fed from a source through pipe P, through its own check valve, vapor seal V, and then extending through opening O to a dry chemical discharge tip. The vapor seals or check valves may be of different designs and locations. Figures 6 and 7 also illustrate a high flow discharge tip HFT and a low flow discharge tip LFT. The discharge tip provides

for discharging dry chemical preferably in three directions, to the left, to the right and adjustably toward the center. The tip might discharge in just one direction, preferably then adjustably toward the center. The discharge tip is preferably adjustable upon installation for anticipated preferred flow rates and directions, given the tank size. For instance, the
5 discharge tip might be adjusted to discharge approximately 70 pounds per second total, 30 pounds per second to the left, 30 pounds per second to the right and 10 pounds per second toward a central area.

The foregoing description of preferred embodiments of the invention is presented for purposes of illustration and description, and is not intended to be exhaustive or to limit
10 the invention to the precise form or embodiment disclosed. The description was selected to best explain the principles of the invention and their practical application to enable others skilled in the art to best utilize the invention in various embodiments. Various modifications as are best suited to the particular use are contemplated. It is intended that the scope of the invention is not to be limited by the specification, but to be defined by the
15 claims set forth below. Since the foregoing disclosure and description of the invention are illustrative and explanatory thereof, various changes in the size, shape, and materials, as well as in the details of the illustrated device may be made without departing from the spirit of the invention. The invention is claimed using terminology that depends upon a historic presumption that recitation of a single element covers one or more, and recitation of two
20 elements covers two or more, and the like. Also, the drawings and illustration herein have not necessarily been produced to scale.

CLAIMS

What is claimed is:

1. A system for treating a flammable liquid fire associated with a tank having a roof and a substantially enclosed space above liquid in the tank and below the roof,
5 comprising:

establishing a foam/film blanket over at least 90% of a surface of the liquid within the tank; and

discharging dry powder into a space between the roof and said blanket.

2. The method of claim 1 wherein the discharging step is subsequent to
10 establishing at least two-thirds of an NFPA regulated foam/film blanket.

3. The method of claim 1 wherein the discharging occurs during the last 10 minutes of an NFPA regulated time of application of foam.

4. An industrial scale tank with a roof having a substantially enclosed space above a flammable liquid in the tank and below the roof, comprising:

15 at least one opening communicating with the space;

means associated with the tank for creating a foam/film blanket on the

liquid; and

means associated with the at least one opening for discharging dry chemical into the space.

5. A fixed foam/dry chemical system for an industrial size tank with a roof having a space above a flammable liquid in the tank and below the roof, comprising:

at least one foam conduit fixed to the tank, in valved fluid communication with an interior of the tank; and

25 at least one dry chemical conduit fixed to the tank, structured for attachment to a source of dry chemical and in valved fluid communication with the space under the roof of the tank.

6. The apparatus of claim 5 including at least three said foam conduits spaced around the tank and at least three said dry chemical conduits spaced around the tank and structured such that at least one foam chamber and one dry chemical conduit
30 communicate with the interior of the tank through one opening in a tank wall.

7. The apparatus of claim 5 including a nozzle for discharge of dry chemical attached to the dry chemical conduit.

8. A system for extinguishing a fire of a difficult to extinguish fuel or flammable liquid in a storage tank fitted with at least a significant fixed top roof portion, comprising:

5 discharging foam into a cavity above the fuel/liquid and below the fixed top roof portion; and

 after at least two-thirds of the way through a NFPA-recommended application rate/duration procedure guideline for the foam attack, discharging dry chemical into a cavity above the fuel/liquid and below the fixed roof portion.

9. The system of claim 8 that includes discharging dry chemical in the last ten
10 minutes of the NFPA recommended application rate/duration procedure guideline.

10. The system of claim 8 that includes discharging dry chemical for 5 to 15 seconds.

11. The system of claim 8 that includes discharging dry chemical after at least 40 minutes of foam application.

12. The system of claim 8 that includes discharging dry chemical through at
15 least one tank vent.

13. The system of claim 12 wherein the vent is an eyebrow vent.

14. The system of claim 12 wherein the vent is a tank roof vent.

15. The system of claim 8 that includes a floater on top of the fuel/liquid and the
20 discharging of foam and of dry chemical is a discharging into a cavity defined between the floater and the fixed top roof portion.

16. The system of claim 8 wherein the fuel or flammable liquid comprises a blended fuel.

17. Apparatus for extinguishing a difficult to extinguish fuel or flammable liquid
25 fire in a storage tank with a fixed roof portion and at least one vent opening into a space defined above the fuel/liquid surface and a fixed roof portion, comprising;

 a storage tank containing a difficult to extinguish fuel or flammable liquid and having a fixed roof portion defining a space or cavity above the fuel/liquid surface and below the fixed roof portion; and

30 a dry chemical supply pipe system rising along a portion of the tank wall having at least one end opening into a tank vent venting the space or cavity, the pipe system in fluid communication with a source of dry powder.

18. The apparatus of claim 17 wherein the supply pipe system has multiple ends inserted into multiple tank vents.

19. The apparatus of claim 17 wherein the vent comprises a wall eyebrow vent.

20. The apparatus of claim 17 wherein the vent comprises a roof vent.

5 21. The apparatus of claim 17 wherein the supply pipe system is permanently affixed to the tank.

22. The apparatus of claim 17 wherein the supply pipe system is portable.

23. The apparatus of claim 17 that includes a floater, and wherein the space defined above the fuel/liquid surface is space defined above the floater.

10 24. The apparatus of claim 17 wherein the difficult to extinguish fuel or flammable liquid comprises a blended fuel.

1/3

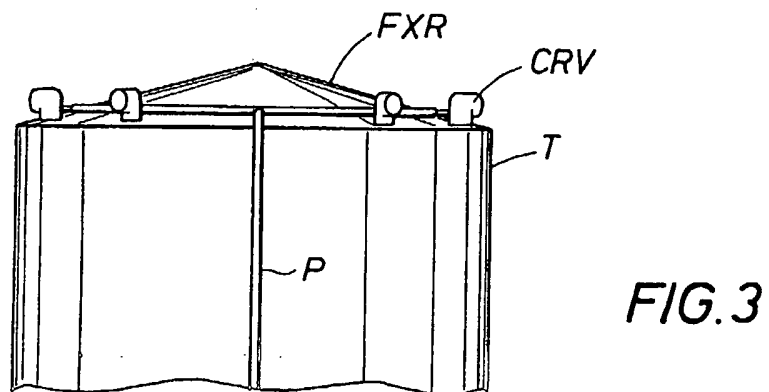
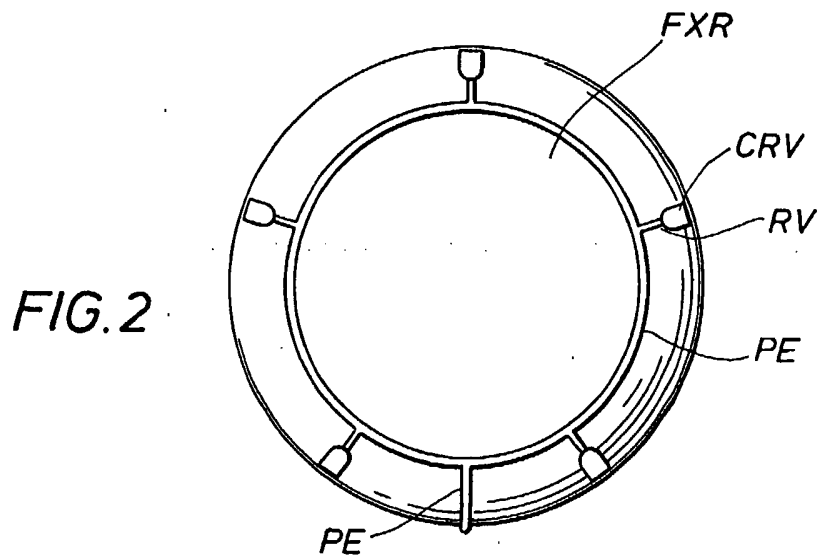
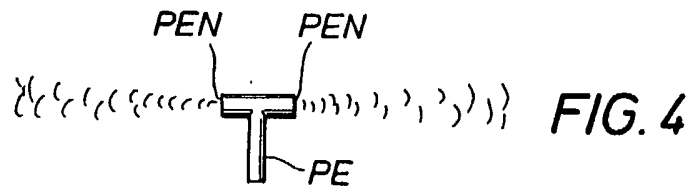
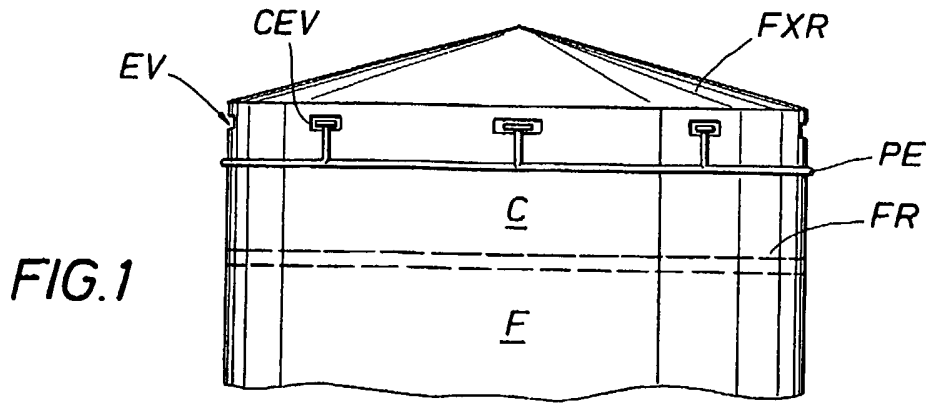

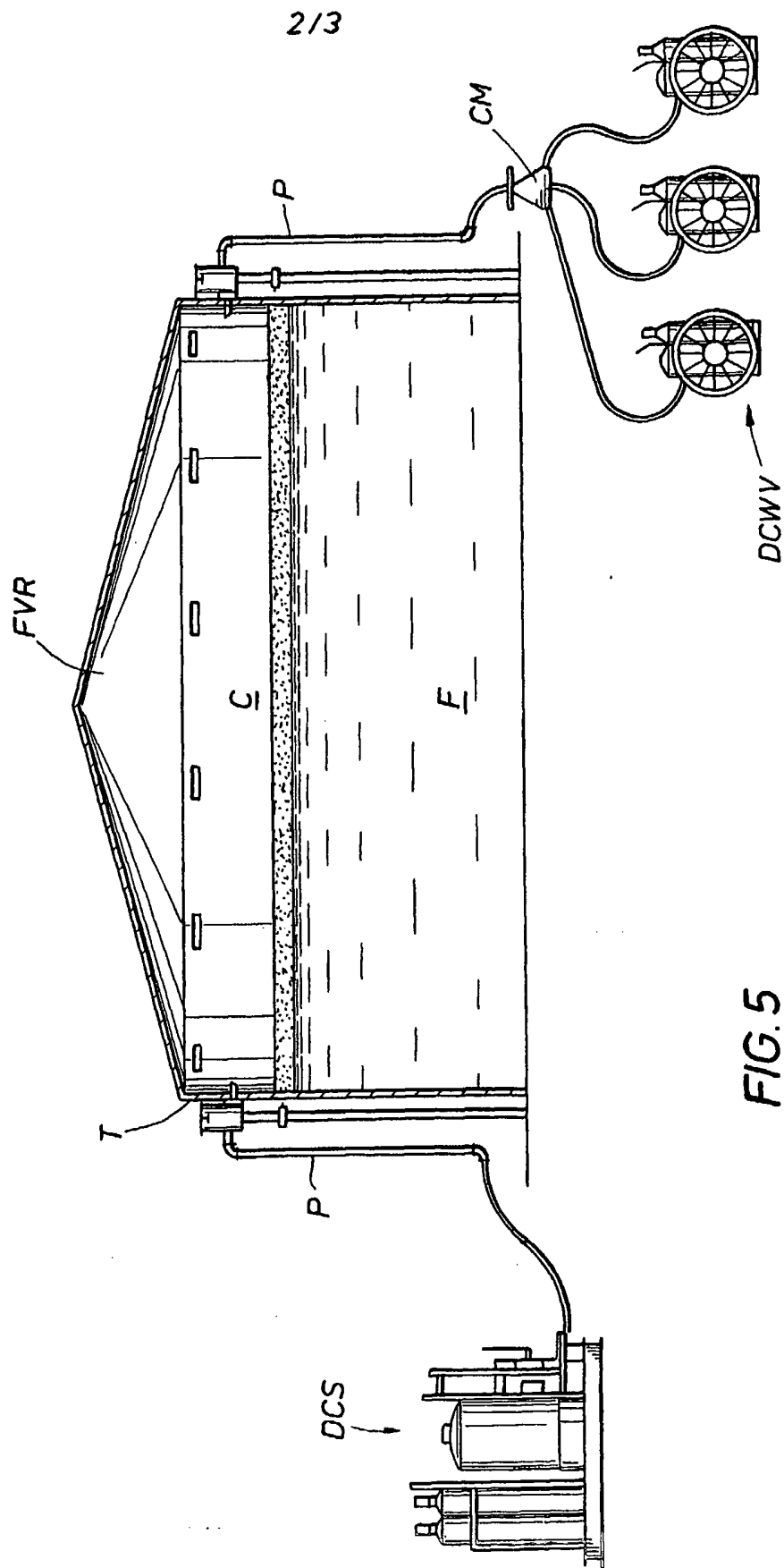

FIG. 5

