

[54] **TOOTHBRUSH**

[72] Inventor: **James A. Holly**, Richton Park, Ill.

[73] Assignee: **Hollymatic Corporation**

[22] Filed: **April 5, 1971**

[21] Appl. No.: **131,246**

[52] U.S. Cl. **15/167 R, 15/201**

[51] Int. Cl. **A46b 15/00**

[58] Field of Search.....15/167, 169, 201, 184

[56] **References Cited**

UNITED STATES PATENTS

| | | | |
|-----------|--------|----------------------|----------|
| 2,882,544 | 4/1959 | Hadidian..... | 15/167 R |
| 2,935,755 | 5/1960 | Leira et al..... | 15/167 R |
| 3,082,457 | 3/1963 | Lucibello et al..... | 15/167 R |
| 3,386,118 | 6/1968 | Morioku et al..... | 15/201 X |

Primary Examiner—Peter Feldman
Attorney—Hofgren, Wegner, Allen, Stellman & McCord

[57] **ABSTRACT**

A toothbrush and the like comprising a brush head elongated along its longitudinal axis and having longitudinal sides, a hollow interior and an elongated bottom opening, a plurality of individual brush units in the head each projecting a plurality of tufts through the opening but each being retractable into the hollow interior of the brush head when subjected to an external force and brush urging means in the hollow head for urging each brush unit toward the opening to project the tufts therethrough and end guide means in the brush head snugly engaging the end surfaces of the brush units for guiding movement of the units individually inwardly of the head when subjected to an external force sufficient to overcome the urging means of the individual unit. The brush units are spaced apart at the sides to provide liquid flow paths communicating with the hollow interior of the brush head for cleaning purposes and each brush unit has two or more tufts aligned transversely to the longitudinal axis of the brush head.

12 Claims, 4 Drawing Figures

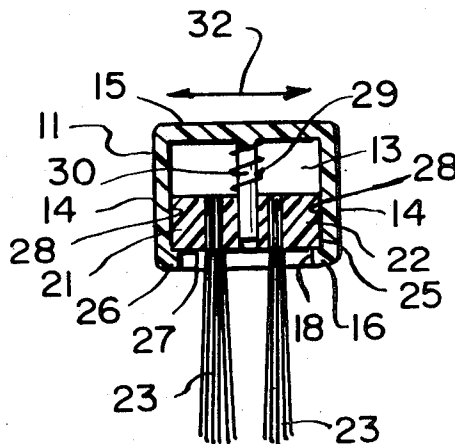

FIG. 1

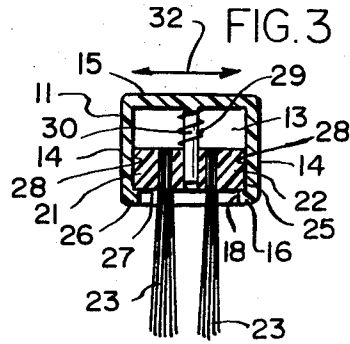
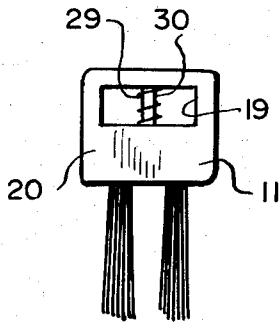

FIG. 2

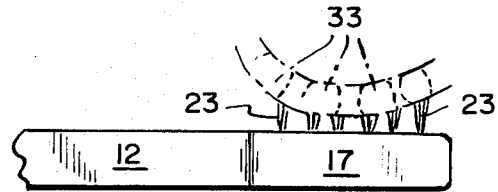
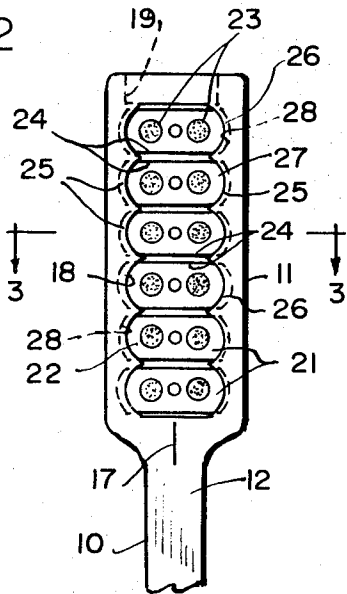

FIG. 4

INVENTOR.
JAMES A. HOLLY
BY *Hofgren, Wegner, Allen,*
Sullivan & McCord.
ATTORNEYS.

TOOTHBRUSH

BACKGROUND OF THE INVENTION

One of the features of this invention is to provide an improved toothbrush and the like comprising retractable brush units arranged in the head of the brush and urged outwardly into tuft projecting position but yieldable inwardly under an external force together with guide means for guiding the inward and outward movement of each brush unit in which the guide means comprises a single guide pin for each brush unit.

Another feature of the invention is to provide such a brush in which there are provided means spacing the sides of the brush units apart to provide liquid flow paths communicating with the hollow interior of the brush head and with the head having a liquid outlet from the interior thereof spaced from the opening that contains the movable brush units.

Another feature of the invention is to provide an improved toothbrush and the like having side-by-side transverse brush units in the brush head each retractable under an external force and each having a plurality of brush tufts aligned transversely of the length of the brush head so that each unit performs as a miniature individual brush, all cooperating to produce more efficient cleaning of complexly contoured surfaces such as teeth and between the teeth.

DESCRIPTION OF THE PRIOR ART

U.S. Pats. Nos. 2,882,544; 2,935,755 and 3,082,457 disclose toothbrushes with retractable brush units each including a tuft projecting from a brush head but retractable into the head under an external force on the tufts. In these prior patents each brush unit contains only a single tuft and is therefore relatively small so that there is considerable danger of jamming and binding because lateral forces on each of the individual tufts tend to move it sideways of the head and jam the unit in its opening in which it is designed to be movable inwardly and outwardly of the brush head. The brushes of this invention avoid this difficulty as each brush unit is elongated transversely of the brush head and is guided in its movement relative to the head at three spaced areas: at the two opposite ends and at the center.

SUMMARY OF THE INVENTION

The toothbrush and the like of this invention provides a plurality of side-by-side brush units each containing a plurality of tufts at least some of which are aligned laterally transversely to the longitudinal axis of the brush head so as to give stability to the brush units thereby preventing them binding in the head even when subjected to strong lateral forces. In certain embodiments the brush units are spaced from each other a small but significant distance to provide for liquid flow into and out of the hollow interior of the head during cleaning. There is also provided an outlet opening in the head communicating with the interior and spaced from the elongated opening that contains the brush units.

BRIEF DESCRIPTION OF THE DRAWINGS

FIG. 1 is an end elevational view from the head end of a toothbrush embodying the invention.

FIG. 2 is a bottom elevational view of the head end of the toothbrush.

FIG. 3 is a transverse sectional view taken substantially along line 3—3 of FIG. 3.

FIG. 4 is a semi-diagrammatic view illustrating the operation of the brush in cleaning teeth.

DESCRIPTION OF THE PREFERRED EMBODIMENT

In the embodiment illustrated in the drawings the toothbrush 10 comprises a brush head 11 on the end of a customary handle 12. The brush head 11 has a hollow interior chamber 13 defined by side walls 14, a top wall 15 and a bottom wall 16. The brush head is elongated along a longitudinal axis 17 so that the side walls 14 comprise the longitudinal sides of the head that are substantially parallel to the axis 17.

Located in the bottom wall 16 is an elongated bottom opening 18 having retaining means 26 along the sides of the opening and thereby defining the opening. There is also provided a liquid outlet from the hollow interior 13 of the brush head with this outlet opening comprising a somewhat large free flow opening 19 in the end wall 20 of the brush head 11.

Located within the hollow interior 13 of the brush head 11 are a plurality of side-by-side brush units 21 each having a solid back 22 and a plurality of projecting tufts 23, here shown as two. Each brush back 22 is elongated in a direction transverse to the longitudinal axis 17 and each has parallel sides 24 between rounded ends 25.

Each brush unit 21 is retained in the hollow interior 13 by retaining means comprising edge flanges or ledges 26 at the sides of the bottom opening 18 and each engaging the outer surface 27 of its brush back in the region of a rounded end 25.

The edge flanges 26 are in the form of narrow ledges that are wide enough to retain the brush backs within the hollow interior 13 of the brush head but that are narrow enough for lateral distortion away from each other by outward bending of the side walls 14 in forcing a brush back 22 from the exterior of the head into the interior thereof to the position shown in FIG. 3. Thus in one example where the brush head was made of a rigid but flexible plastic material such as nylon the edge flanges 26 were 0.015 inch wide (shown exaggerated in the drawings for illustrative purposes). The brush units were easily "snapped" into the interior 13 by forcing the opposite flanges 26 apart a sufficient distance to permit the brush backs 22 to pass therebetween.

The rounded ends 25 of each brush unit 21 engage similarly rounded interior surface portions 28 that define the sides of the hollow interior 13 and these surface portions 28 form end guide means that snugly engage the end surfaces 25 of the brush units for aid in guiding the movement of the units 21 individually inwardly of the brush head when subjected to an external force as illustrated in FIG. 4 sufficient to overcome the urging means that urge the individual units outward. In the illustrated embodiment this urging means comprises a helical spring 29 for each brush unit 21 and positioned around a pin 30 for each brush unit 21.

The pins 30 comprise another part of the guide means in that they slidably engage the brush backs 22 substantially centrally thereof so that the combination of the single pin 30 for each brush back 22 and the end guide surfaces 28 cooperate to guide the internal and external movement of each brush unit individually of

the others so that there can be no binding or jamming of the brush units during use.

The brush of this invention also includes spacing means spacing the sides 24 of adjacent brush units apart a short distance to provide liquid flow paths between the units communicating with the hollow interior 13 of the brush head for aid in cleaning the head as by holding it under running water. In the illustrated embodiment this spacing is about 0.015 - 0.025 inch (shown exaggerated in FIG. 2 for illustrative purposes) and is provided by the rounded ends 25 engaging the rounded head surface portions 28 in snug engagement so as to hold the brush units against substantial lateral movement parallel to the longitudinal axis 17. The plurality of tufts 23 are symmetrically arranged on each unit and laterally aligned in a direction transversely to the longitudinal axis 17. Thus each pair of tufts 23 in each brush back 22 in the illustrated embodiment are aligned at right angles to the axis 17 which is the direction of normal up and down teeth 33 cleaning movement as illustrated by the arrow 32. Each brush unit 21, therefore, functions as a miniature, self-adjusting and separate brush unit with a plurality of tufts aligned in the preferred direction for teeth cleaning.

The guide pins 30 are rigidly mounted on the top wall 15 so as to project toward the bottom wall 16 and terminate short of the bottom opening 18 so that when the brush backs 22 are in fully projected positions as shown in FIG. 3 the outer ends of the pins are even with or slightly below the outer surfaces 27 of the brush backs 22. All of the pins 30 are parallel to each other, parallel to the brush unit end surfaces 25 and parallel to the end guide surfaces 28. Each pin 30 is also positioned centrally within the chamber 13 between the side walls 14.

Where the brush head 11 is made of the preferred plastic material such as nylon each pin 30 may also be made of plastic material and as shown in FIG. 3 is preferably made integral with the top wall 13.

As can be seen from the above description each small brush back 22 requires only a single supporting and guiding pin 30 which is wholly contained within the hollow interior chamber 13. This conserves internal space and the pin engaging each brush back 22 in combination with the rounded ends 25 snugly engaging the interior guide surfaces 28 that form the inner surfaces of the side walls 14 cooperate to retain each brush back 21 against twisting and jamming during the full extent of its movement from the complete extended position of FIG. 3 through and to a completely retracted position adjacent the top wall 15. These guide surfaces including each pin 30 also maintain the narrow spacing between adjacent sides 24 of the brush backs for proper cleaning of the brush.

The assembling of the springs 29 and brush units 21 within the hollow brush head 11 is quite simple. Because the parallel pins 30 are integral parts of the brush head particularly when the head and pins are made of a molded plastic and because of the small overlap (such as about 0.015 inch) of the edge flanges or ledges 26 all that is necessary to assemble the parts of the brush together is to place each spring 29 over its pin 30 while the brush is held inverted, then snap the brush unit 21 through the opening 18 by forcing it past the edge flanges 26 in an action where the ends of the unit serve to force the walls 14 and flanges 26 apart

enough to permit entry of the brush back 22 past the flanges, and then repeat this operation for each brush unit, spring and pin assembly until all brush units 21, here shown as six in number, each with its own spring and each mounted on its own pin are in position.

Having described my invention as related to the embodiment shown in the accompanying drawings, it is my intention that the invention be not limited by any of the details of description, unless otherwise specified, but rather be construed broadly within its spirit and scope as set out in the appended claims.

I claim:

1. A toothbrush and the like usable with a liquid in cleaning, comprising: a brush head elongated along its longitudinal axis and having longitudinal sides, a hollow interior, an elongated bottom opening, retaining means along the sides of the opening and a liquid outlet from said interior spaced from said opening; a plurality of individual brush units in said brush head retained therein by said retaining means and each having a projecting brush tuft, each said unit having end surfaces adjacent the longitudinal sides of said brush head; brush projecting urging means in said hollow head for urging each said unit toward said opening to project said tufts therethrough; and guide means in said brush head snugly engaging said end surfaces of said brush unit for guiding the movement of the units individually inwardly of the head when subjected to an external force sufficient to overcome said urging means of the individual unit; and spacing means spacing the sides of said brush units apart to provide liquid flow paths communicating with said hollow interior of said brush head.

2. The brush of claim 1 wherein said brush units are elongated between said end surfaces transversely to said longitudinal axis.

3. The brush of claim 2 wherein each said brush unit has a plurality of said tufts symmetrically arranged on each unit and laterally aligned transversely to said longitudinal axis.

4. The brush of claim 1 wherein each said brush unit has substantially parallel sides transverse to said longitudinal axis, and each said brush unit has a plurality of said tufts symmetrically arranged on each unit and laterally aligned transversely to said longitudinal axis.

5. The brush of claim 1 wherein said retaining means comprises edge flanges at said bottom surface overlapping said brush unit end surfaces.

6. The brush of claim 5 wherein said edge flanges are of narrow width for lateral distortion of said head in forcibly moving a brush unit into said hollow interior past said flanges.

7. The brush of claim 1 wherein there are also provided a guide pin in said brush head hollow interior for each said brush unit located centrally of the brush unit on which the brush unit is slidably movable during its said movement, all said pins being parallel to each other, parallel to said brush unit end surfaces and side surfaces, and parallel to said end guide means.

8. The brush of claim 7 wherein said urging means for urging said brush unit comprises a helical spring positioned around a said pin.

9. A toothbrush and the like, comprising: a brush head elongated along its longitudinal axis and having longitudinal sides, a hollow interior, an elongated bottom opening and retaining means along the sides of the

5

6

opening; a plurality of individual brush units in said brush head retained therein by said retaining means and each having a plurality of projecting brush tufts, each said unit having end surfaces adjacent the longitudinal sides of said brush head; brush projecting urging means in said hollow head for urging each said unit toward said opening to project said tufts therethrough; and end guide means in said brush head snugly engaging said end surfaces of said brush unit for guiding the movement of the units individually inwardly of the head when subjected to an external force sufficient to overcome said urging means of the individual unit.

10. The brush of claim 9 wherein said brush units are elongated between said end surfaces transversely to said longitudinal axis, each said brush unit has a plurality of said tufts symmetrically arranged on each unit and laterally aligned transversely to said longitudinal axis and each said brush unit has substantially parallel sides

5

10

15

20

25

30

35

40

45

50

55

60

65

transverse to said longitudinal axis.

11. The brush of claim 9 wherein said retaining means comprises edge flanges at said bottom surface overlapping said brush unit end surfaces and said edge flanges are of narrow width for lateral distortion of said head in forcibly moving a brush unit into said hollow interior past said flanges.

12. The brush of claim 9 wherein there are also provided a guide pin in said brush head hollow interior for each said brush unit located centrally of the brush unit on which the brush unit is slidably movable during its said movement, all said pins being parallel to each other, parallel to said brush unit end surfaces and side surfaces, and parallel to said end guide means, and said urging means for urging each said brush unit comprises a helical spring positioned around a said pin.

* * * * *