

H. CROSBY, Jr.  
SEWING MACHINE.

No. 10,878.

Patented May 9, 1854

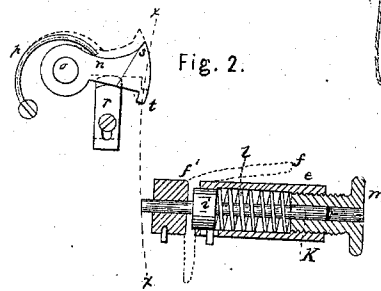
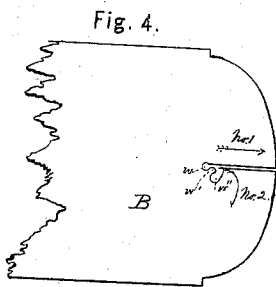
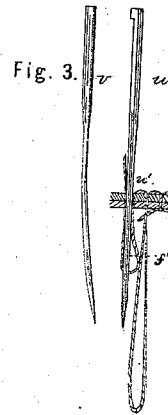
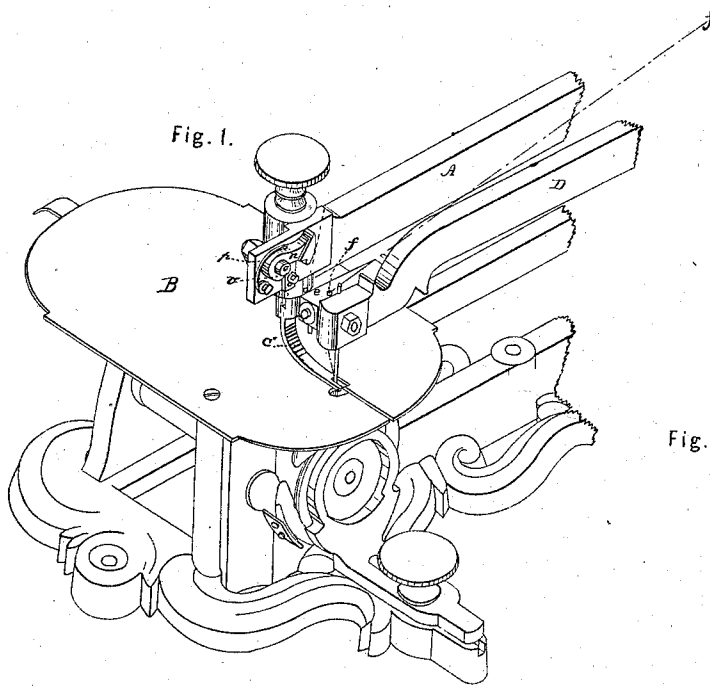

# UNITED STATES PATENT OFFICE.

HEMAN CROSBY, JR., OF WATERTOWN, CONNECTICUT.

## IMPROVEMENT IN SEWING-MACHINES.

Specification forming part of Letters Patent No. **10,878**, dated May 9, 1854.

*To all whom it may concern:*

Be it known that I, HEMAN CROSBY, JR., of Watertown, county of Litchfield, and State of Connecticut, have invented certain new and useful Improvements in Sewing-Machines; and I do hereby declare that the following is a full, clear, and exact description of the same, reference being made to the annexed drawings, making a part of this specification, in which—

Figure I is a perspective view, exhibiting my improvements attached to a sewing-machine. Figs. II, III, and IV are of parts in detail; and similar letters refer to similar parts throughout.

My invention consists, first, in so constructing and applying the friction-brake upon the thread that in rapid work on harsh material I obviate the breaking of the thread at the period of greatest strain, and it is particularly applicable to that class of sewing-machines in which the stitch is made by passing the bight or double of a thread through the cloth, thus forming a loop on the reverse side, through which loop a secondary thread is to be passed, and then the loop is to be drawn tight by the returning motion of the needle, or by a stitch-hook below, or by the joint action of both. To effect this drawing tight, some check is necessary to the free passage of the thread from the reel, inasmuch as but for that the stitch-hook would not draw, as it should, upon the loop only, but would take the thread required for its next movement as much from the reel as from the last loop, thus leaving a succession of unfinished stitches. To obviate this, various devices acting as permanent or continuous brakes upon the reel have been adopted. For light materials—such as muslin or cloth—these have proved sufficient; but when employed upon harsher material—such as leather—they are inadequate, since to draw back the loop in these it is found necessary that the thread should be locked to the needle or to the needle-carrier at all times except at the precise moment in each stitch when an amount of thread equal to the length required to make one perfect stitch is to be fed. This result I accomplish without danger of breaking the thread at the moment of greatest tension.

A second improvement consists in the form of the needle, whereby in sewing leather or

other similar article the hole is so made that the process of finishing the stitch is greatly facilitated.

As an exponent of the class of sewing-machines to which I have herein referred, perhaps the best known is that for which Letters Patent were issued to A. B. Wilson, June 15, 1852, and I will therefore describe my invention as applied to one of these.

In the accompanying drawings, Figure I represents in perspective a part of one of said Wilson's machines, A being the permanent piece which extends over the plate or table B, and to which the curved bar C, pressing upon the cloth, is secured. At D is the vibrating arm which carries the needle. Upon the side of this arm I place a box of metal, as shown at *e*, having a hole, *f'*, through it at the place where the thread *f* should pass down. The box *e* is shown in Fig. II partly in section and enlarged. It is bored out through a part of its length, so that a button, *i*, may play freely in the chamber. This button is mounted upon a guide-pin, *k*, one end of which passes through the front of said box, so as to have easy play longitudinally. The button is kept pressing against the end of the chamber, or against the thread if that is then between, by a spiral spring, *l*, the pressure of which can be graduated by the set-screw *m*, as clearly shown. The hole *f'* through the box, for the thread to pass, is made at the end of the chamber and a little to one side of the center, in order that the thread may pass by the guide-pin *k*, and thus the thread will be constantly locked, except when the button *i* shall be pushed back from that end of the chamber. When the thread is to be fed out, the button *i* is to be withdrawn. This is accomplished by placing a cam upon some fixed part of the machine in the path of vibration of the projecting end of the guide-pin as the box moves with the arm D. This cam has a curved surface, in order that on passing it the projecting end *k* shall be driven back when moving over the highest part of the cam, and it must also be so placed on the machine that it shall operate at the precise point of the stroke at which it is desired that the thread should be fed. In the present machine this condition is met by placing it on the permanent bar A, as shown

at *n*, Fig. I. As it is only desired that the cam *n* should operate to unlock the thread on a downward motion of the needle, it is fixed upon a center at *o*, in order that as the vibrating arm rises the projecting end of *k* may lift said cam by striking against its lower edge, as shown in Fig. II, where the arc or path of vibration is seen in the dotted lines *xx*. The projecting end of *k* thus passes the cam on the upward movement without being driven back, and the cam drops into place again, resting upon an adjustable stop at *r*, to be ready for the downward stroke, a spring, *p*, facilitating that motion.

It is obvious that the curved face of the cam from *s* to *t*, Fig. II, must be of such form and length as will keep the pin *k* pressed back during a portion of the stroke long enough to permit the required amount of thread to pass through at the proper time of feeding. This length of face to be in contact may be adjusted by the movable stop *r*, upon which the cam rests, since it is evident that if this be raised the end of *K* will be so much sooner disengaged during the downward stroke of the needle, as clearly shown in the positions of the cam and stop indicated by dotted lines in Fig. II.

In the machines above referred to, the drawing back of a portion of the loop occurs while the needle is passing out and before the whole of it has retired from the cloth. To facilitate this process is the purpose of the second part of my invention; and it consists in enlarging the needle in that part of it which last enters the cloth for so much only of the length of the needle as will, at the lowest point of the stroke, but just pass that enlarged part through the cloth, and this enlargement is on that side of the needle next the last stitch, for the reason that as soon as stitch-hook enters the new loop *f''* just forming on the needle the thread on that side will be drawn downward by the action of the stitch-hook while the needle will be moving upward, and these opposite directions make it necessary in harsh materials—such as leather—that freedom of motion should be secured to the thread.

In Fig. III a magnified side view of the needle is given at *v* and a front view at *u*, showing the enlarged part. In the latter view the needle is shown in the act of retiring, the enlarged part *u'*, having passed out of the leather, and the loop *f''* on the needle having just formed for the stitch-hook to enter.

Fig. IV is a plan view of the plate B on which the work rests. In this a slot is usually cut along the plate from the opening *w*, through which the needle plays, in line with the straight feed to the edge of the plate. While the feed is in the direction indicated by the arrow No. 1, this straight slot is all that is required; but when a curved line is to be sewed, as in the direction shown by the arrow No. 2, (being that in which the operator makes by far the greater number of the curves in prac-

tical sewing,) the threads extending below the cloth come, by the act of turning, in contact with the metal of the plate B, and thus the perfect drawing up of the loop is impeded. That portion of the plate immediately around the path of the needle is required to support the material being sewed, and hence cutting away any part thereof to correct the evil must be done with some care. The needle passes downward at *w*. The loop is taken upon the stitch-hook and the needle retires. The drawing up of this loop is not completed until the feed of the cloth has occurred for the needle to enter in a new place. The cloth having therefore been moved on to the length of one stitch, the turning may take place at a point always one stitch from the place of the needle, and here I cut away the plate, as shown at *w''*, leaving the point *w'* to support the cloth during the passage of the needle through it.

The operation of the machine as thus improved will be as follows: When a stitch has been partially formed, leaving a loop only to be drawn up to complete said stitch, the operation of drawing that up is a part of the process of forming the next stitch, and the stitch-hook enters the new loop just before the needle passes back out of the cloth. The onward revolution of the stitch-hook, combined with the upward motion of the needle, draws that first loop close; but the thread being fixed to the needle-carrier, it cannot be drawn through the eye by the stitch-hook, and hence that must take its supply from the loop left at the last stitch. The greatest strain upon the thread is just before it is "cast off" from the stitch-hook, as well known in these machines, and it is at this point that to prevent breaking the thread I intermit the action of the friction-brake upon the thread and permit the feed then to take place. By means of the set-screw *m*, the degree of pressure of the securing apparatus may be so determined that, if desired, the thread may partially slip through, and thus any required degree of tightness of the sewing may be secured, since it would only be necessary to so adjust the cam that nearly the required amount would pass while the apparatus was unlocked, leaving the remainder to be drawn under some tension. The enlarged part of the needle leaving the leather before the stitch-hook has commenced to draw up the loop left at the next preceding stitch, as hereinbefore described, the thread of the last-formed loop has full liberty to pass down through that hole while the remainder of the needle is retiring, instead of being cut or binding, as usual.

What I claim as of my own invention, and desire to secure by Letters Patent of the United States, is—

1. The adjustable cam or its mechanical equivalent, in combination with the friction-brake, for the purpose of intermitting the action of the brake upon the thread during the feed, and thus obviating the danger of sun-

dering the thread in rapid work during that moment of extreme tension, as set forth.

2. Enlarging that portion of the needle which, having entered the material, is to retire from it before the pull upon the last loop is commenced, in the manner and for the purpose described, the whole being constructed

and operating substantially in the manner set forth.

HEMAN CROSBY, JR.

Witnesses:

S. H. MAYNARD,

O. T. SIMMONS.