

(19) World Intellectual Property Organization
International Bureau



(43) International Publication Date
18 June 2009 (18.06.2009)

PCT

(10) International Publication Number
WO 2009/075587 A1

(51) International Patent Classification:
E02B 11/00 (2006.01) *E01C 13/08* (2006.01)
E01C 13/02 (2006.01)

(74) Agent: **ABC-PATENT, SIVILING. ROLF CHR. B. LARSEN A.S.**; Brynsveien 5, N-0667 Oslo (NO).

(21) International Application Number:
PCT/NO2008/000443

(81) Designated States (unless otherwise protection available): AE, AG, AL, AM, AO, AT, AU, AZ, BA, BB, BG, BH, BR, BW, BY, BZ, CA, CH, CN, CO, CR, CU, CZ, DE, DK, DM, DO, DZ, EC, EE, EG, ES, FI, GB, GD, GE, GH, GM, GT, HN, HR, HU, ID, IL, IN, IS, JP, KE, KG, KM, KN, KP, KR, KZ, LA, LC, LK, LR, LS, LT, LU, LY, MA, MD, ME, MG, MK, MN, MW, MX, MY, MZ, NA, NG, NI, NO, NZ, OM, PG, PH, PL, PT, RO, RS, RU, SC, SD, SE, SG, SK, SL, SM, ST, SV, SY, TJ, TM, TN, TR, TT, TZ, UA, UG, US, UZ, VC, VN, ZA, ZM, ZW.

(22) International Filing Date:
12 December 2008 (12.12.2008)

(25) Filing Language: Norwegian

(26) Publication Language: English

(30) Priority Data:
20076433 13 December 2007 (13.12.2007) NO
20084034 23 September 2008 (23.09.2008) NO

(84) Designated States (unless otherwise indicated, for every kind of regional protection available): ARIPO (BW, GH, GM, KE, LS, MW, MZ, NA, SD, SL, SZ, TZ, UG, ZM, ZW), Eurasian (AM, AZ, BY, KG, KZ, MD, RU, TJ, TM), European (AT, BE, BG, CH, CY, CZ, DE, DK, EE, ES, FI, FR, GB, GR, HR, HU, IE, IS, IT, LT, LU, LV, MC, MT, NL, NO, PL, PT, RO, SE, SI, SK, TR), OAPI (BF, BJ, CF, CG, CI, CM, GA, GN, GQ, GW, ML, MR, NE, SN, TD, TG).

(71) Applicant (for all designated States except US): **OLDROYD SYSTEMER AS** [NO/NO]; Kragerø Næringspark, N-3766 Sannidal (NO).

(72) Inventor; and

(75) Inventor/Applicant (for US only): **CHEETHAM, John, Oldroyd** [GB/NO]; Gartneriveien 3, N-3770 Kragerø (NO).

Published:
— with international search report
— before the expiration of the time limit for amending the claims and to be republished in the event of receipt of amendments

(54) Title: DRAINAGE SYSTEM AND METHOD FOR INSTALLATION OF DRAINAGE SYSTEM

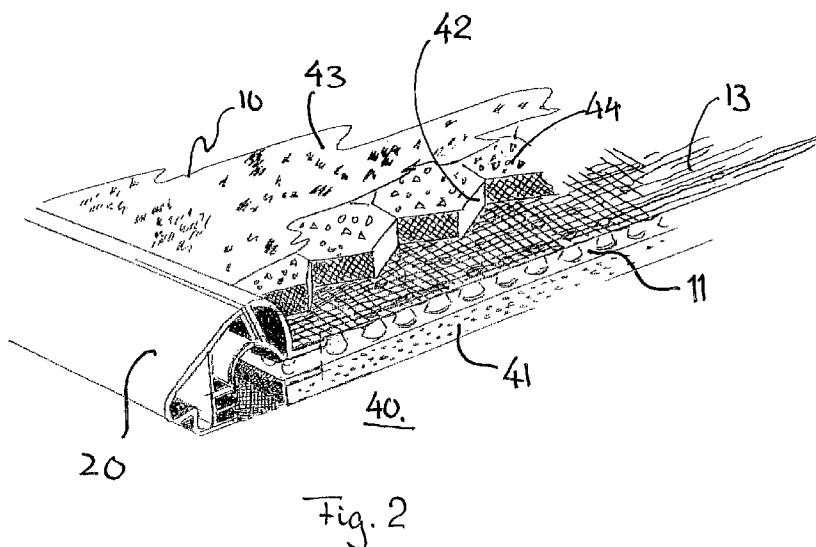

(57) Abstract: The invention comprises a system for the draining of water from an arena (10) such as a riding paddock, a sand volley court, a football pitch and the like where on a substrate is applied a watertight barrier (11) in the form of a sheet or film of a plastic material. In connection with the said watertight barrier (H) on at least one side of an arena (10) is installed a side wall (15) which sticks up from the watertight barrier (11), the side wall (15) being so constructed as to form a watertight connection between the barrier (11) and the side wall (15) in order to drain away water and that the side wall(s) (15) is/are so constructed as to lock the barrier (11) against movement in a vertical and/or horizontal direction away from the side wall (15) when the side wall (15) is connected to the barrier (11). The invention also concerns the procedure for installation of such a system.

WO 2009/075587 A1

DRAINAGE SYSTEM AND METHOD FOR INSTALLATION of DRAINAGE
SYSTEM

The present invention relates to a system for
5 draining a surface, such as for example football pitches,
sand volley and tennis courts, riding paddocks, golf
courses, playgrounds and other sports and recreation areas
or to create a pool or area of water suitable for a
skating rink for example. The system comprises a
10 watertight membrane and an integrated drainage system for
removing water in a controlled fashion which otherwise
would have had to drain into the ground. The system can
also include boundary wall components.

15 Background for the invention.

Arenas such as, for example, riding paddocks, sand
volley courts, football pitches and the like under the
open sky are subjected from time to time to rainfalls of
differing intensity. This can result in the area being
20 laid under water or at least becoming soft and unsuitable
for the intended purpose.

It is known to drain such arenas with trenches with
drainage systems comprising drain pipes covered by filter
cloth and hard core material, such trenches running in
25 both directions along and across the area in question.
However sand volley courts for example are often built for
shorter periods, in such cases a more or less permanent
drainage system is not very practical.

A membrane with an attached filter cloth is also
30 known, allowing water to filter through the cloth whilst
fine material and particles are held back.

These known methods have the disadvantage that
draining is often insufficiently effective, that costs are
high and that periodic maintenance is necessary since fine
35 material has a tendency to block the drainage system.

There is therefore a need for a simple drainage system making it possible to establish areas as dry as possible without large and comprehensive building works and where the need for maintenance is reduced. There is
5 also a need to reduce the cost of such installations.

Summary of the invention

One objective of the present invention is to provide an improved drainage system for arenas giving a dry
10 surface even during heavy rain.

Another object of the invention is to provide an improved drainage system not requiring extensive building works prior installation.

A further object of the invention is to provide a
15 drainage system which, by simple means leads water away from the arena in question in a regulated and controlled fashion.

A further object of the invention is to provide a drainage system which is simple to establish and has a
20 reduced need for periodic maintenance.

An additional objective has been to provide a drainage system which is easy to dismantle so that the installation is quick to dismantle and re-erect on another site for either permanent or temporary use.

25 Another objective of the present invention is to provide a drainage system which is inexpensive to produce and where the site preparation costs are low.

Yet another objective is to provide a method for the installation of the system, the said method making
30 installation easy and esthetically attractive.

A further objective of the invention is to ensure that the filter cloth and drainage membrane do not unintentionally loosen from each other and/or from an eventual surrounding edge.

Another objective of the invention is to provide an underlying system having resilient and shock absorbing properties, particularly but not exclusively for football pitches and riding arenas.

5 The objectives of the present invention are achieved by a system described in more detail in the independent patent claim. Different types of embodiments based on the invention are defined in the dependent patent claims.

10 According to the invention a watertight barrier, for example in the form of plastic sheets or membranes, is laid in an overlapping pattern so that between two rows of such sheets or membranes a drainage channel is provided which is preferably in fluid connection with a drainage channel along the area's periphery. Furthermore, a
15 stabilizing cellular mat is applied, resting on the previously mentioned sheets or membrane and is open in the vertical direction but with walls in a sideways direction. This stabilizing cellular mat is filled with a material with good drainage properties and is preferably made from
20 non-woven fibers.

 According to another form of application along at least one side of the arena and in connection with the previously mentioned watertight membrane an edging profile rising up from the membrane and arranged to form a
25 watertight connection between itself and the membrane. Furthermore this edging profile is formed in such a way as to hinder any vertical or horizontal movement of the watertight membrane when connected to the profile thus locking the membrane in place.

30 In another embodiment the edging along the side or sides of the arena can be formed as a hollow oblong shaped body with a base plate and a U-shaped body connected to this base plate.

 In another form of the invention the oblong shaped

hollow body is hinged to the base plate so that the hollow body can swing along a line which lies along the non-arena side of the profile.

The hinge connection can preferably be in the form of a lengthwise bead on the base plate onto which a
5 corresponding lengthwise groove on the hollow portion can be clipped.

The base plate and the oblong, hollow element described can preferably form an integrated unit where the
10 hinge connection is in the form of a reduced section so that the hollow element can swing on this lengthwise reduced section.

The watertight barrier can preferably be locked in place by a leg on the hollow body the bottom of the leg
15 being bent right angles to the leg itself and where the distance between this horizontal portion of the leg and the base plate corresponds to the height of the studs on the watertight membrane. The studded membrane is thus locked in position along its length when this hollow
20 section is installed.

A means of locking the oblong hollow section to the base plate and the membrane to the side can be incorporated.

The same hollow section can be formed with at least
25 one channel in a lengthwise direction to hold advertising panels, safety equipment, marking tapes etc.

One or more additional elements can be attached to the top of the upper section in order to raise the height of the perimeter wall.

30 During installation of the drainage system the membrane can be locked in position along at least one edge by inserting the membranes free edge into the perimeter wall system and locking it, using the locking system incorporated in the hollow oblong section comprising the

perimeter wall.

Short description of the drawings

5 Embodiments of the system in accordance with the present invention will be described in more detail with reference to the drawings where:

10 Figure 1A shows schematically an arena with membrane sheets and drainage channels according to the invention, seen from above before the drainage material has been applied;

Figure 1B shows a section of an arena, for example for riding, with membrane and perimeter boundaries according to the present invention;

15 Figure 2 shows in perspective and part a vertical section through an alternative embodiment of the present invention;

Figure 3 shows a vertical section through an alternative embodiment of the perimeter edging profile according to the present invention;

20 Figure 4 shows a vertical section at A-A, see Figure 1B, through the membrane and the perimeter boundary profile according to the present invention;

Figure 5 shows an enlarged vertical section marked B in Figure 4;

25 Figure 6 shows a view of adjacent membrane sheets according to the present invention seen from above;

30 Figure 7 shows a vertical section through one embodiment of a joint between two adjoining sheets incorporating a drainage channel seen along line A-A Figure 6;

Figure 8 shows a vertical section through an alternative perimeter boundary intended to surround at least part of, for example, a football field;

Figure 9 shows a vertical section through another

embodiment of perimeter boundary according to the present invention designed for coupling to a standardized drainage pipe;

5 Figure 10a shows a vertical section through an alternative design of a drainage channel for use between two adjoining drainage sheets;

Figure 10b shows a vertical section through an alternative embodiment of end joint and/or edge;

10 Figure 11 shows an assembled drainage system intended to lie between adjoining sheets and drainage channels; and

Figure 12 shows schematically a system for the collection of drainage water coming from the system via the drainage channels.

15

Detailed description of the invention.

Generally, Figures 1A and 1B show schematically an arena seen from above. The arena 10 where it is important to drain away water has a foundation of, for example, gravel or a layer of concrete or asphalt. At times it is complicated to ensure sufficiently good drainage of rainwater and surface water from such an arena. Such arenas can be permanent or temporary for use as sand volley courts, riding arenas, football pitches, skating rinks etc. In order to ensure good drainage watertight membranes or sheets 11 of a plastic material are laid on the substratum, such membranes or sheets having a degree of stiffness so that they can lie with an even slope towards a drainage channel. In connection with these sheets a channel system 56 consisting of channels running in the lengthwise and/or crosswise direction of the arena. Suitable fittings are used for joining together the channels leading the water out. The water is lead through the channels in a direction indicated by the arrows in

20

25

30

Figure 1A. The sheet 11 is preferably formed with upward rising studs 12 arranged in a pattern. On top of the studs 12 is either glued or welded fast a filter cloth 13 of a construction which allows water to pass through whilst retaining fines, gravel, sand, earth and the like. Onto the filter cloth 13 a layer of sand, earth or similar material is laid depending upon the arenas intended use. When it rains water will pass through the sand, gravel or earth and down through the filter cloth 13 whilst the materials above are held back. Water drains thereafter onto sheet 11 and is lead away from the arena 10 to the perimeter from where it is lead away through a connected system of pipes.

In order to ensure that the layer of earth 14 is kept in place and hindered from sliding or being washed away from the arena 10 perimeter profiles 15 resting on the ground are positioned round the arena and rise above ground level to a height preferably but not necessarily higher than the height of the layer 14 of sand, earth or the like. Where large areas are to be covered sheets are laid in overlapping lengths so that a continuous and preferably watertight membrane is formed on the ground 16. In this connection see Figures 2, 6 and 7, the studs 12, in this connection together with the jointing profile 31, can according to the invention be used to position and hold two adjoining sheets 11 in place.

Perimeter edging 15 can be formed from a series of similar sections put together to form, with the help of corner profiles 32, a continuous edge 15 round the whole of the arena 10. The ends of each section can for this purpose be made interlocking, alternatively jointing sockets can be used together with corner profiles 32. Such jointing sockets being made so that the sections entering these do so as to form a connecting joint without sharp

edges.

Figure 2 shows in perspective part of a vertical section through an arena 10 of the type mentioned above with football pitches or tennis courts as typical examples. When laying such an arena 10 a level substrate 40 must first be established. If it is desirable to protect the area from cold or heat an insulating layer 41 of firm material for example expanded polystyrene is laid. Thereafter studded membrane sheets 11 with welded filter cloth 13 are laid according to the invention. The sheets 11 with filter cloth 13 are laid in an overlapping pattern so that a more or less watertight joint is formed between the adjoining sheets 11. The filter cloth 13 can for this purpose be stretched sideways longer than the studded sheet 11. Along the arenas 10 perimeter edge profiles 20, to be described in more detail under, are employed. On top of the sheets 11 with filter cloth stabilizing mats 42 of, for example, non-woven polypropylene or polyethylene fiber are laid and filled with earth or a gravel containing material 44. The mats can have a height of, for example 5, 10 or 15 cm and can be filled with a material with good drainage characteristics but not necessarily with good sideways stability such as shingle. Alternatively ordinary drainage material can be used. The object of using stabilizing mats is to achieve a sideways stabilizing of the materials whilst maintaining good vertical and/or horizontal drainage. The sections 42 can, with advantage, have hexagonal shape since this gives a stable solution and since the sections can be also supplied in ready made mats into which the earth or gravel containing material 44 can be filled after laying. Even though a hexagonal shape is preferred other shapes for example triangular, square or many sided are possible. The object of the sections 42 is to establish a stable base for the top layer 43 and to

simplify laying so that a plane underlay for the top layer 43 is established in an efficient way. Additionally this type of solution makes it possible to use less material which increases the drainage effect and contributes to quicker draining and easier application of the materials.

Fig.3 shows a vertical section through an alternative design of an edge profile 20. This edge profile 20 is designed with a straight, vertical wall 45 configured to face inwards towards the arena 10. The profile 20 comprises two separate parts which together form edge profile 20. The upper part can preferably consist of a hollow, closed portion 46 where the lower part has a longitudinal groove 47 stretching along the whole length of a side and constructed to function together with a tongue on the other element 48 so that a hinge acting lower edge is established. The bottom end of the profile 20 functions as a drainage channel for leading away water flowing from the top side of the sheet 11. Instead of a horizontal base the bottom of channel 55 can also be formed as a continuation of the circular shape for which space must be made in the underlying ground. An opening at the bottom of the profile 52 is formed by the upper and lower lips 53 and 54. The opening communicates with the internal channel 55. When installed the edge of a sheet 11 is inserted in the opening 52 and is held in place by the lips 53,54. In this way water which trickles along sheet 11 enters the profile and can be lead out through channel 55. When the sheet 11 is pushed into the opening 52 the inner wall 45 is forced upwards since the tongue and groove joint 47,56 acts a sprung hinge. To ensure a good grip the height of the opening 52 can be somewhat less than the height of the sheet 11 thus establishing a downward gripping pressure.

It should be mentioned in this connection that this

profile can be made in one piece as shown in Figure 3.

As indicated the profile has a sloping side 49 and a top surface 50 which has a lengthwise slit 51. This slit can be used to fasten advertising boards or other material designed to stand up from perimeter profile. Alternatively the slit 51 can be used to fasten a protective sheet to be drawn over the arena when this is not in use. The slit 51 can also be used to fasten marking lines to divide the arena in sections for a particular sport.

Figure 4 shows a vertical section through another embodiment of the perimeter wall 15 seen along line A - A in Figure 1B. Preferably the wall 15 rests freely on the substrate (not shown) without being fastened to it. Alternatively the perimeter wall 15 can be fastened to the substrate so that it can move neither vertically nor transversally. Any suitable fastening method can be chosen for example by making the periphery wall 15 with a flange, preferably on the opposite side to that facing the arena, which can be anchored to the substrate with spikes.

According to the present invention the perimeter edge 15 also has a function to drain water running along sheet 11 away from the arena 10. To ensure that this water is led away the perimeter edging 15 and the sheet 11 with filter cloth 13 are designed to form a watertight connection between the edging 15 and the sheet 11.

As shown in Figure 4 the perimeter edging 15 incorporates a base plate 17. This base plate can stick out sideways either inwards towards the arena or outwards away from the arena or in both directions. The base plate 17 can, on the side away from the arena, have a vertical wall 18 stretching the whole length of the perimeter edging and having a beading shaped top 19. The base plate 17 can be shaped to form a channel under the perimeter edging 15 to lead away collected water.

In addition to the base plate 17 the perimeter edging 15 also comprises an upper part 20. This upper part can have an inverted U-shape where the open end of the U-shape faces downwards towards the base plate 17. This upper body can preferably be hinged to the base plate along the edge on the base plate facing away from the arena so that this upper body can be swung up from the base plate 17 along this outside edge. In order to make this hinge connection possible the lower edge on the side of the section 20 facing away from the arena 10 is provided with an open downward facing longitudinal pocket 21 shaped like a Y. This longitudinal pocket 21, open underneath, is designed to snap onto the longitudinal bead 19 along the top edge of the vertical section 18 of the base plate 17.

As is also shown in Figure 4 the upper body 20 can be formed as a hollow, separate, closed body 22 running the whole length of the perimeter wall 15. In the form shown in Figure 4 this hollow body 22 is an integral part of the upper body 20. It should be noted that this hollow body 22 can also be formed as a separate unit which can be fixed on top of the upper body 20. In yet another embodiment the height of the perimeter can be further increased by mounting additional units (not shown) on top of the upper body 20 or on the hollow body 22. The upper body 20 or alternatively the mounted or integral hollow body 22 can, along at least the side facing the arena 10, be formed with a channel 23. The upper body 23 can also be formed with longitudinal channels on top and/or on the side facing away from the arena 10. The profile(s) 23 can be used to fasten markings for sand volley ball courts, safety cushions, advertising material and so on. The inward facing channel can also be used to fasten a cover, which can also be watertight, to draw over the court 10

when it is not in use to protect it from, for example, leaves, animal excrement or snow.

As is also shown in Figure 4 the base plate 17 and the upper body 20 have the same cross section and shape along their whole length. These two bodies 17 and 20 are preferably extruded in a plastic material such as a composite material for example but not exclusively WPC (Wood Plastic Composite) or in another suitable plastic material. Alternatively, the base plate 17 can be extruded or made of a stiff solid material whilst the upper portions or components can be made from a softer material. However, it should be pointed out that the base plate 17 and/or the upper body 20 can be made of wood, plastic, glass fiber reinforced polystyrene, metal such as aluminium or similar materials. The upper closed body 22 can be designed so that it can be filled with a material to give extra weight such as water or sand. In such a case each perimeter wall section be given closed ends (not shown) and openings for filling or emptying the above mentioned material.

In accordance with the design shown in Figure 4 the base plate 17 is flat. This solution is, for example, well suited to use on a hard surface such as asphalt, concrete or similar, preferably on a level surface which is more or less self-draining. It should be noted however that the base plate in conjunction with, for example, a gravel substrate where it is not so easy to drain away the water, can have a concave shape which forms a drainage channel for removal of water along the base of the perimeter wall 15. In order to lead the water away the base plate 17 and/or the lower end of the perimeter wall 18 have holes (not shown) which are connected to a pipe (not shown) which carries the water away from the arena 10.

In order to establish a drainage system in

accordance with the invention a sheet 11 with studs 12 is laid in an overlapping pattern with the studs 12 of the underneath sheet being covered by the corresponding void in the overlapping sheet 11. The filter cloth 13 is a little wider than the sheet 11 to which it is attached, so that the filter cloth 13 can also overlap. At the same time as sheet 11 is laid a section of perimeter wall 15 is also laid so that an end of sheet 11 can be entered into the base plate 17. To make this possible the upper part 20 is swung on the hinge connection. When the end of the sheet 11 is in position on base plate 17 the upper part 20 is swung back into position. The inner edge 24 continues a short vertical distance beyond the horizontal foot 30 (Figure 5) and onto a stud thus stopping any lateral movement of the sheet 11 out of the base plate 17. In order to avoid this edge 24 jumping up again and thereby losing its locking function the upper part 20 can be locked to the base plate 17 by a locking arrangement (not shown). In the design shown in Figure 4 locking is by a screw or bolt from a recess 29 and protected by it, entering into part 27 of the base plate 17 and holding the upper body 20 in place. Alternatively the upper part 20 can be clicked into place by the provision of suitable extruded bead and pocket elements.

To ensure a stiff connection between the perimeter wall 15 and the sheet 11 a horizontal part 30 of the upper body 20 is arranged to clamp in position on the top of the studs 12 so that a stable connection is established between the perimeter wall 15 and the sheet 11. The horizontal plate 30 is arranged somewhat above the inner end edge 24 and is configured to rest against the surface 25 of the studs 12, so that a stable, locking connection between the perimeter wall 15 and the plate 11 is established. According to the invention the sheet 11 is

thus prevented from moving vertically or horizontally out of the perimeter wall 15.

As indicated in Figure 4 all the elements constituting the perimeter wall 15 such as the vertical wall 18, the beads 19, the Y-shaped pocket 21, the recess 29, the horizontal plate 30 etc. run lengthwise making the perimeter wall suitable for extrusion.

Although the hinge shown in Figure 4 is of a beading and pocket construction which is snapped on the beading 19 the hinge can take other forms for example a thinner, more flexible longitudinal section along which the upper body 20 can be turned in relation to the base plate 17. In such case the upper part 20 and the base plate 17 will be one unit and not two as shown in Figure 4.

Figures 6 and 7 show schematically a joint between two sheets 11 where one sheet has a flap along the edge 16 which overlaps the joint. Figure 6 shows two sheets 11 seen from above whilst Figure 7 shows a vertical section through the joint at A-A in Figure 6. As shown in Figure 7 a jointing profile 31 is used, made to lie in a shallow trench (not shown) in the ground. Jointing profile 31 consists of a base plate 33 intended to lie on the bottom of this shallow trench. Each side of this base plate 33 is formed as an S 34 with a horizontal supporting surface 35. A centrally positioned column 38 rises up from the base plate 33 to form a central support for a jointing plate 36 designed to tie together the studs on the sheets 11 on each side of the profile 31. For this purpose the plate 36 is equipped with downward facing edges 37. The jointing plate 36 is wide enough to encompass the first row of studs on the sheets 11 on each side of the jointing profile. The jointing profile 31 is stiff enough to support the sheets 11 and forms at the same time one or more longitudinal channels 39 which lead away the drainage

water along the length of profile 31.

Figure 8 shows a cross section of a perimeter wall or edge 15 for a football pitch 10. The height of such a wall can be for example 5 - 15 cm. The perimeter wall or edge 15 has three main functions namely i) to contain the material on the inside ii) to lead away the water draining from the pitch along the sheets 11 and iii) to function as a support for advertising placards, protection mats, fencing posts etc. The perimeter edging 15 is made with a channel 43 designed to receive a fin 54 on a channel shaped body 44. This channel shaped body has a corresponding fin 54 which, together with the fin or edge 53 on the perimeter edging 15 is designed to clamp the sheet 11 with filter cloth 13 so that water running along sheet 11 is collected in the channel 44 to be thereafter led away from the pitch. Although the Figure 8 shows a channel with a semi-circular shape the body 44 can have any suitable shape for example square or rectangular.

Figure 9 shows another embodiment of a perimeter edge 20 according to the invention. In this case the perimeter edging comprises, in relation to the arena 10, an outside element 49, an inside element 45 and a third element 48 which forms the bottom of the drainage channel. These three elements 45,48,49 are designed so that together they form a perimeter wall unit as shown for example in Figure 3, that is to say with a drainage channel and a recess 51 for fastening, for example, advertising placards.

Figure 10a shows schematically a cross section through a drainage channel designed to lie between to adjacent sheets 11 with filter cloth 13 where the channel is intended to lie in the lengthwise direction of the arena and where at least one end is connected to a further channel in the perimeter wall 20.

Figure 10b shows schematically a vertical section through an alternative embodiment of a joint and/or edge according to the invention. According to this embodiment the perimeter edge is in the form of a channel 55 arranged along one edge being provided with to sideways and outwards extending fins 56, extending along the entire length of the body and being designed to lock the plate 11. Between said fins 56 an opening is formed, and since such embodiment is made of one integral body, the circular or oval shape will produce a clamping force.

Figure 11 shows schematically an embodiment of a channel system built up of elements shown in Figure 10 where sockets of different sizes are used whilst Figure 12 shows a collection system including a collection tank 57. Drainage water is led from the arena 10 and led to the collection tank 57 through the drainage channels. The tank 57 is equipped with a pipe 58 through which water can be pumped back to the arena 10 when this is desirable because of drought or when the surface requires watering. For this purpose the piping system is equipped with a pump 59 and valves (not shown).

In a solution according to the present invention water on the arena or falling as rain or melting snow or ice sinks through the surface material of the arena and down through the filter cloth 13. Since the sheet 11 is watertight the water will run along the sheet out to and into the perimeter walls 15. Thereafter the water will run inside the perimeter wall 15, along its length and out to a drain (not shown) leading to a cistern or tank 57.

The membrane according to the invention can be delivered as more or less stiff sheets or in roll form.

The membrane can, according to the invention, be further equipped with fins, grooves and other profiles or patterns to ensure that the membrane lies firmly and

safely on the substrate and which hinder displacement of the membrane sheets during the construction phase.

It should also be noted that the invention can also be applied in connection with ice rinks where the membrane
5 lies on a substrate, cooling pipes are laid between the studs of the membrane with filter cloth and then covered by a layer of gravel or similar material.

The membrane should preferably be thick enough to be robust but nevertheless easy to handle, for example
10 delivered in rolls.

Advertising boards previously mentioned can for example be made in aluminium and can be fastened to a groove in the upper part of the perimeter wall and thereafter bent towards the spectators.

The invention is also suitable for use in connection
15 with skating rinks where a controlled and quick method of removing the water from melting ice is needed. The invention is also suitable for use where damage to the substrate due to sudden, unexpected and large quantities
20 of water is to be avoided.

In order to lock the edges of the watertight sheets to the channels 44,55 wood screws can for example be used. These are screwed through the upper flange 54 and sheet 11 and into the lower flange 56. Similarly screws can be used
25 to fasten the edges of the sheet 11 to the flanges 53,54 on the edge 20.

C l a i m s

1. System for draining water from an arena (10) such as
a riding paddock, sand volley ball court, football pitch
5 and the like where, preferably on a leveled surface,
c h a r a c t e r i z e d b y the use of a watertight
barrier (11) for example in the form sheets or films of
plastic material laid in an overlapping pattern onto each
other, and that between two rows of sheets or film a
10 drainage channel is installed which is preferably in fluid
communication with a drainage channel along the arena's
side/s and that a cellular stabilizing mat rests on said
sheets or film, the said stabilizing mat being open in a
vertical direction and with walls in a sideways direction,
15 intended to be filled with a material with good drainage
properties, the said stabilizing mat preferably being
made of non-woven fibers.

2. System according to claim 1, where one or more
20 drainage channels are established in connection with at
least one of the edges of the said watertight barrier (11)
along a side of the arena (10) and that there is
established a side wall (15), extending up from the
watertight barrier (11), the side wall(s) (15) being
25 configured to form a watertight connection between the
barrier (11) and the side wall (15) and further that the
side wall (15) is configured to lock the barrier (11) from
moving in a vertical direction and/or away from the side
wall (15) when the side wall (15) is connected to the
30 barrier (11).

3. System according to claims 1 or 2, where the said
intermediate drainage channel(s) lying between barrier
sheets being equipped with devices designed to establish a

firm connection between the adjacent sheet(s) and the drainage channel.

4. System according to one of claims 1-3 where the side wall(s) are in the shape of an oblong hollow body designed with a base plate (17) and a U-shaped body associated with the said base plate (17).

5. System according to one of claims 1-2, where the said hollow body is hinged to the base plate (17) so that the oblong hollow body can swing along a line along the side of the side wall which faces away from the arena.

6. System according to claim 5, where the said hinge connection is in the form of a longitudinal beading on the base plate (17) and a corresponding longitudinal pocket or groove (21) on the hollow body (21) into which said pocket or groove (21) preferably snaps onto the longitudinal beading.

7. System according to claim 5 where the said base plate (17) and the oblong hollow body (20) form an integrated body and where a line of reduced cross section or weakening allows the hollow body (20) to be swung along this line.

8. System according to one of claims 1-7, where the watertight barrier (11) is locked by a downward pointing leg (24) on the hollow body (20).

9. System according to claim 8, where in connection with the downward pointing leg (24) a flange (30) is arranged at more or less a right angle to the leg (24), and where the distance between the said flange (30) and the base

plate (17) corresponds essentially to the height of one or more studs (12) on the barrier (11), so that plate (30) clamps down on the said one or more studs (12) when the unit (17,20) is fixed in position on the barrier (11).

5

10. System according to one of claims 1-9 where, in connection with the attachment between the base plate (17) and the oblong hollow body (20), there is arranged a locking device which locks the oblong hollow body (20) to the base plate (17) and which locks the barrier (11) to the side wall (15).

10

11. System according one of claims 1-10, where the oblong hollow body (20) is equipped with at least one longitudinal channel for fastening marking tapes, advertising placards, safety equipment, such as safety nets or similar.

15

12. System according to one of claims 1-11, where one or more additional elements can be placed on top of the upper body in order to raise the height of the side wall (15).

20

13. Method for installing a drainage system for an outdoor arena (10) such as a riding paddock, volley ball court, football pitch or similar where a watertight barrier/membrane (11) is laid on a level surface and where the membrane (11) also includes a filter cloth (13) which allows the passage of water but holds back particle material, the filter cloth (13) being positioned on the top side of the membrane (11) and that the membrane (11) is equipped with upward facing studs (12),

25

30

characterised by the membrane being locked by a side wall round at least part of the arena and where the membrane's free end is entered into the side wall (15) and

is thereafter locked with the help of a lock incorporated in the side wall.

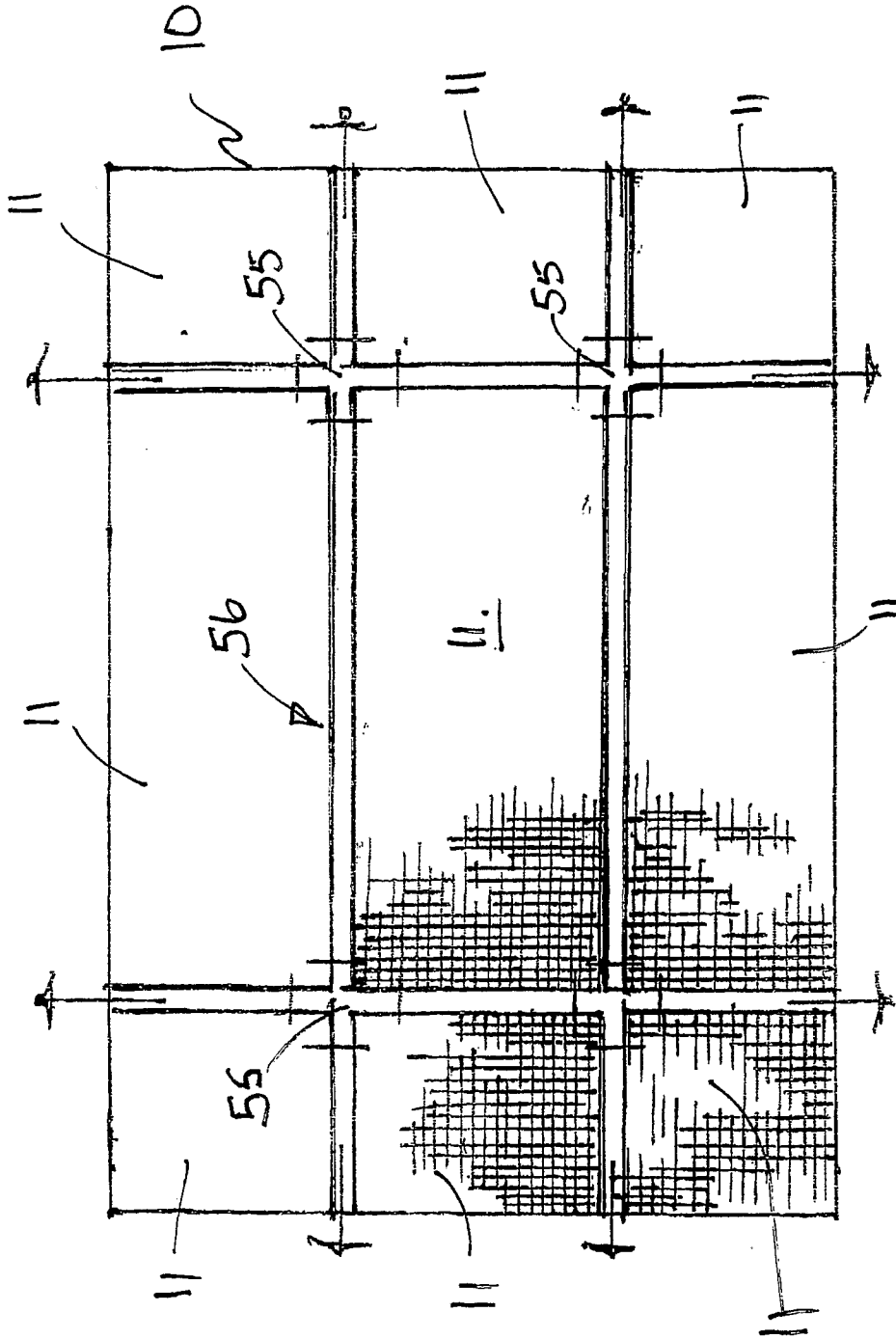

Fig. 1A

2/9

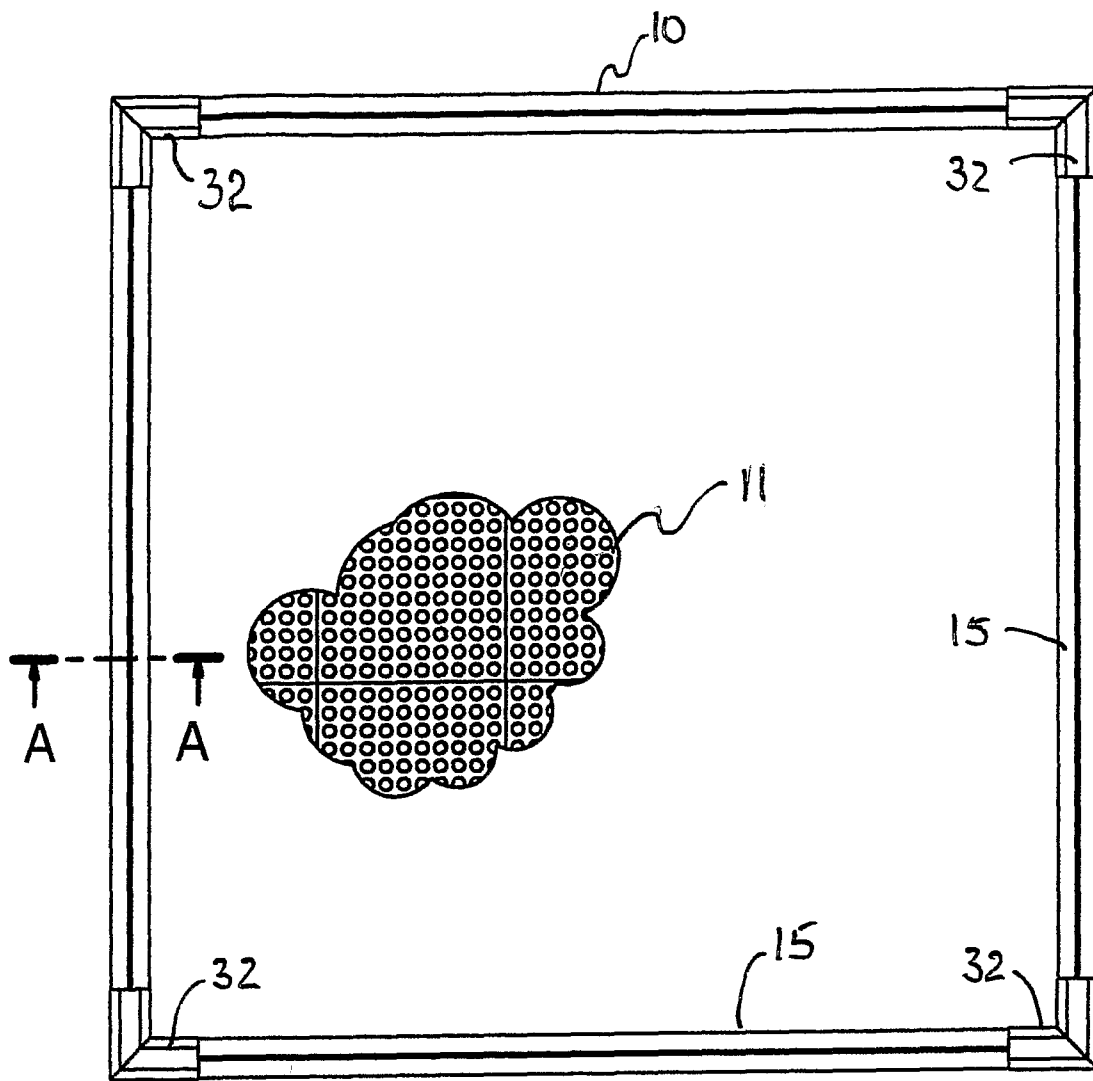

Fig. 1B

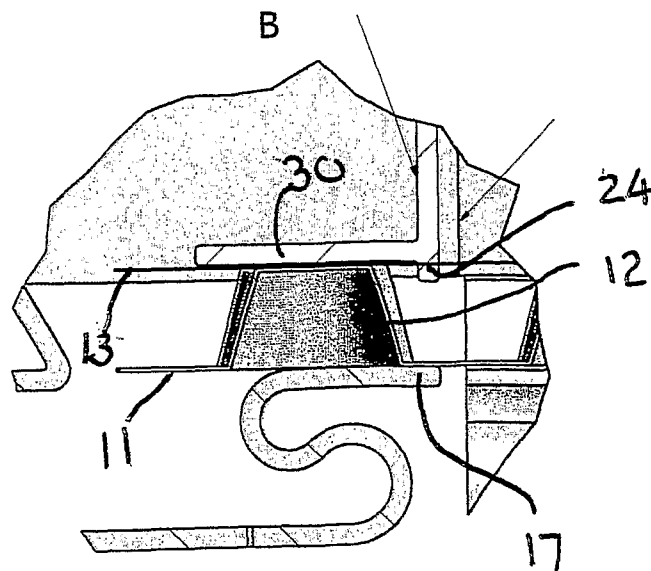

Fig. 5

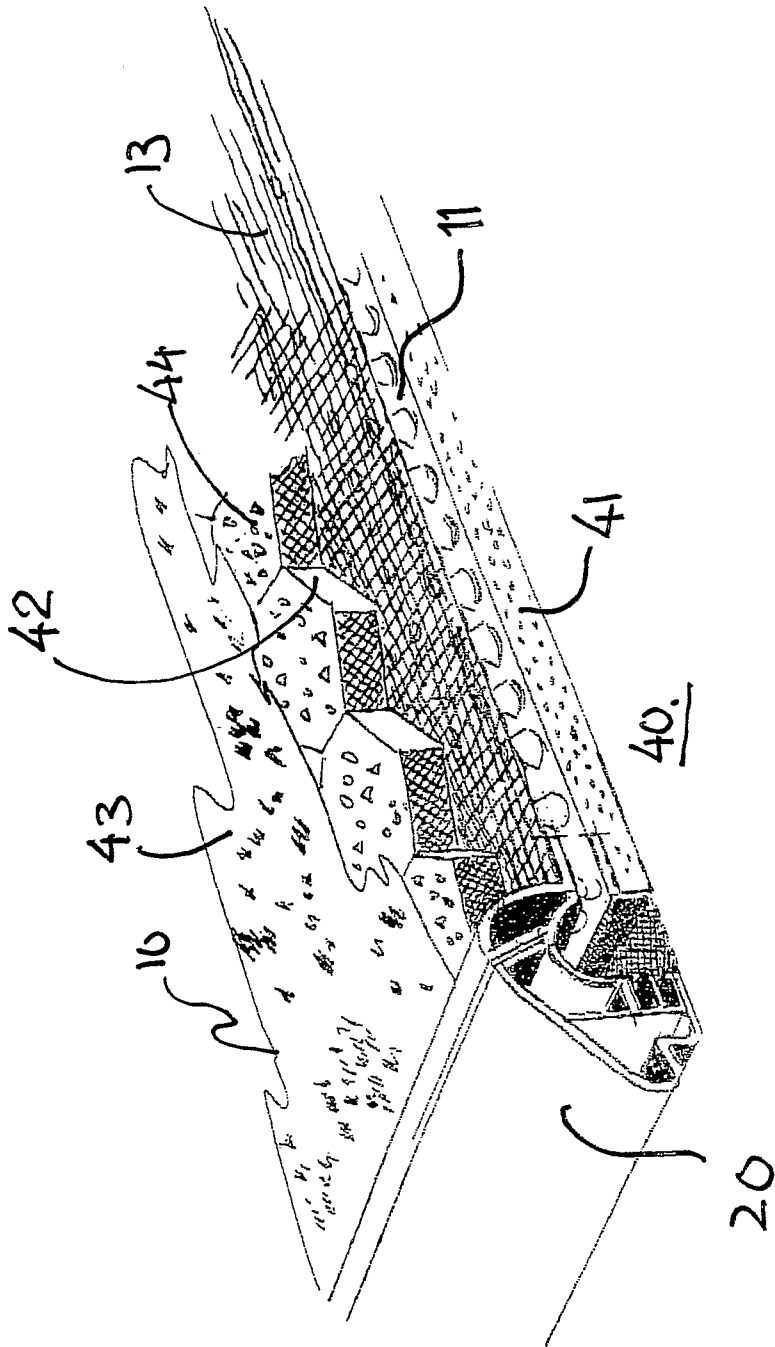

Fig. 2

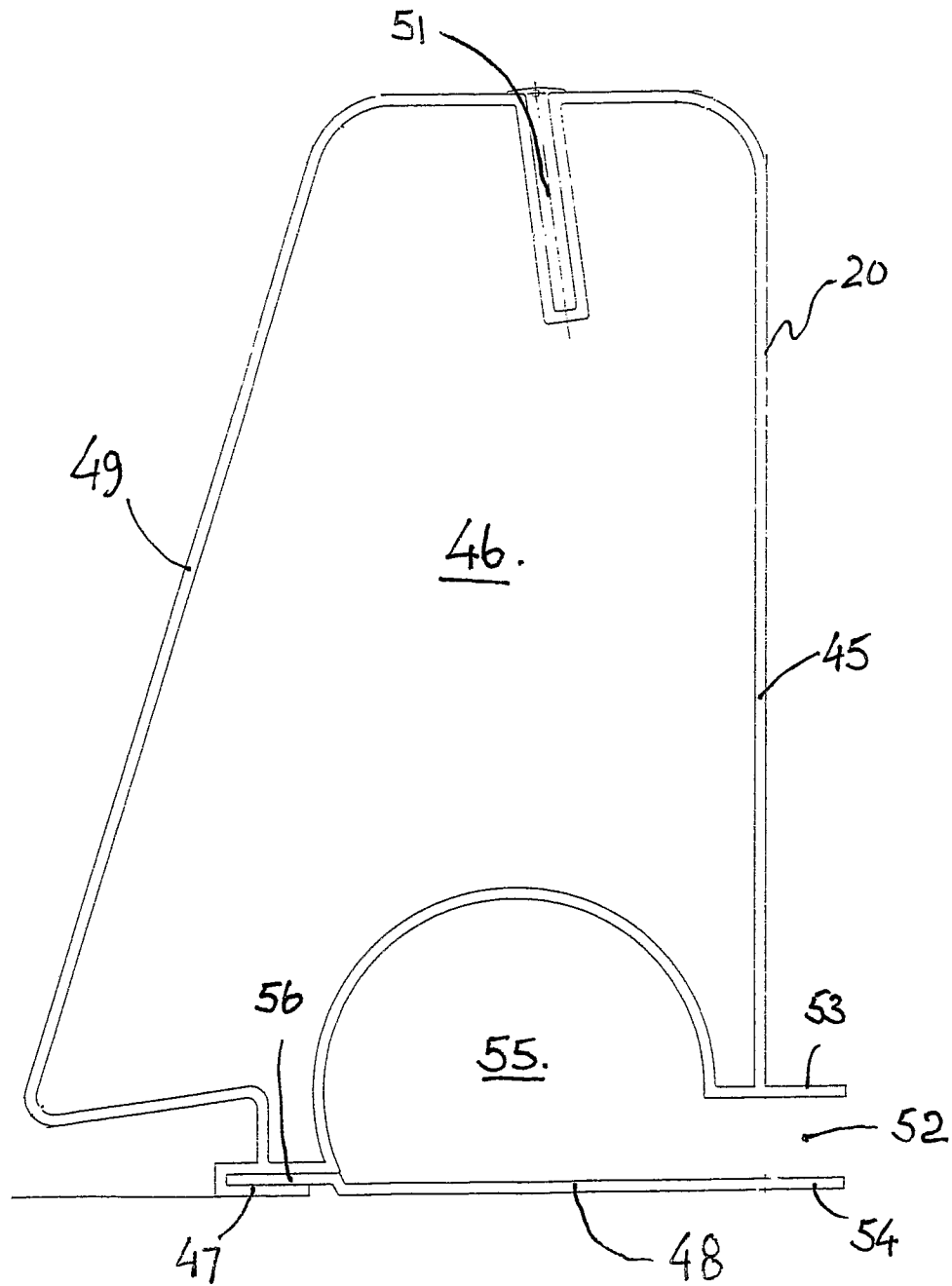

Fig. 3

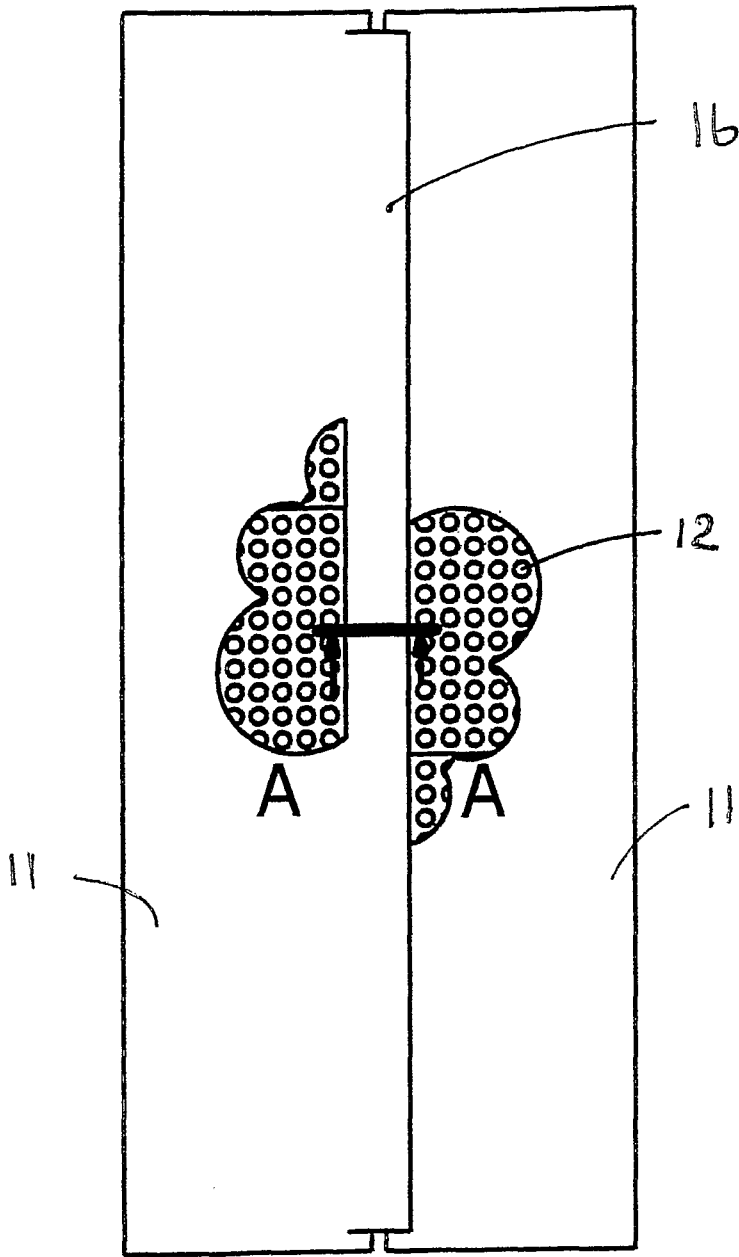

Fig. 6

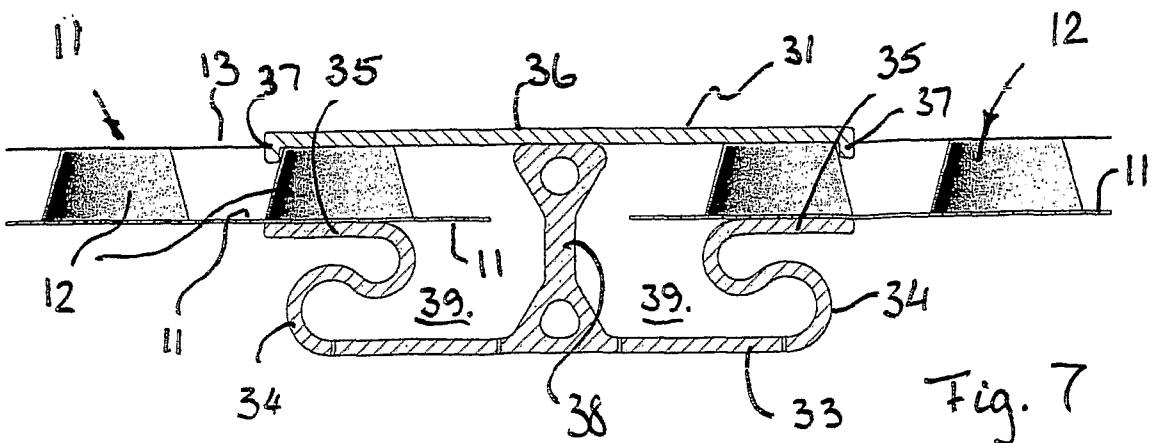

Fig. 7

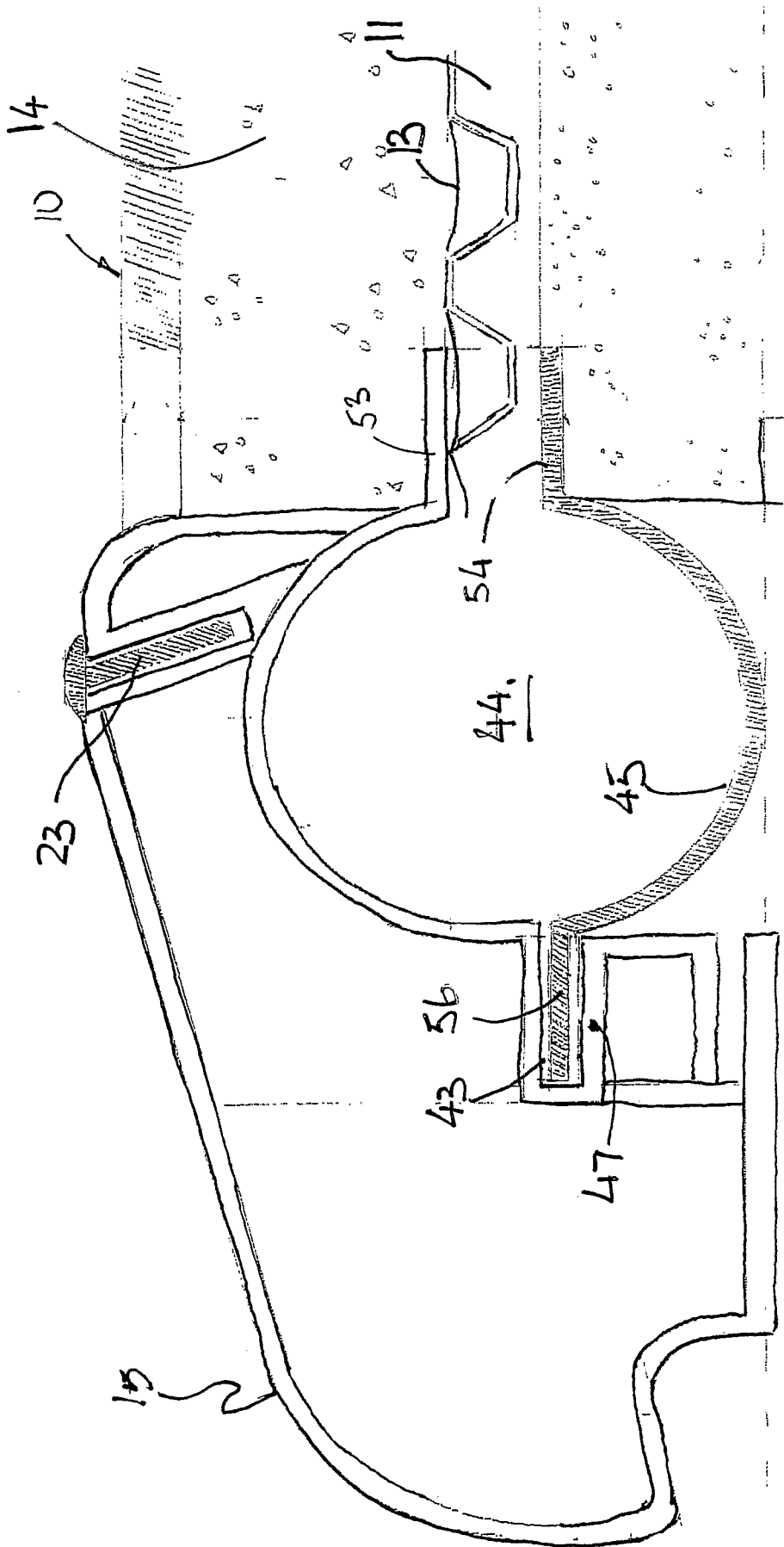

Fig. 8

8/9

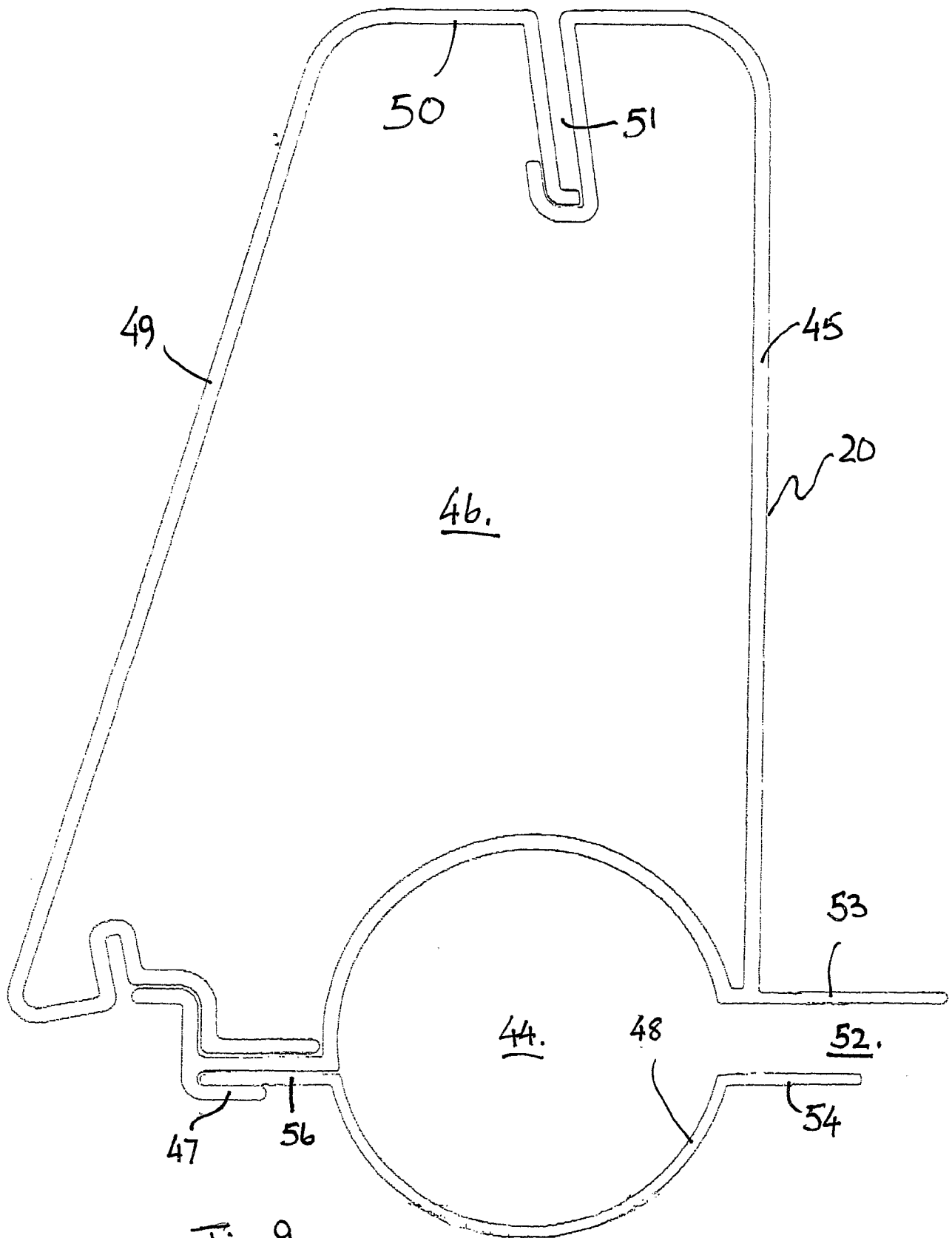
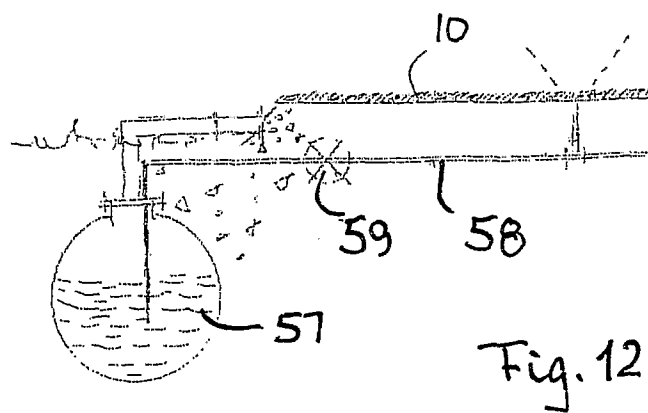
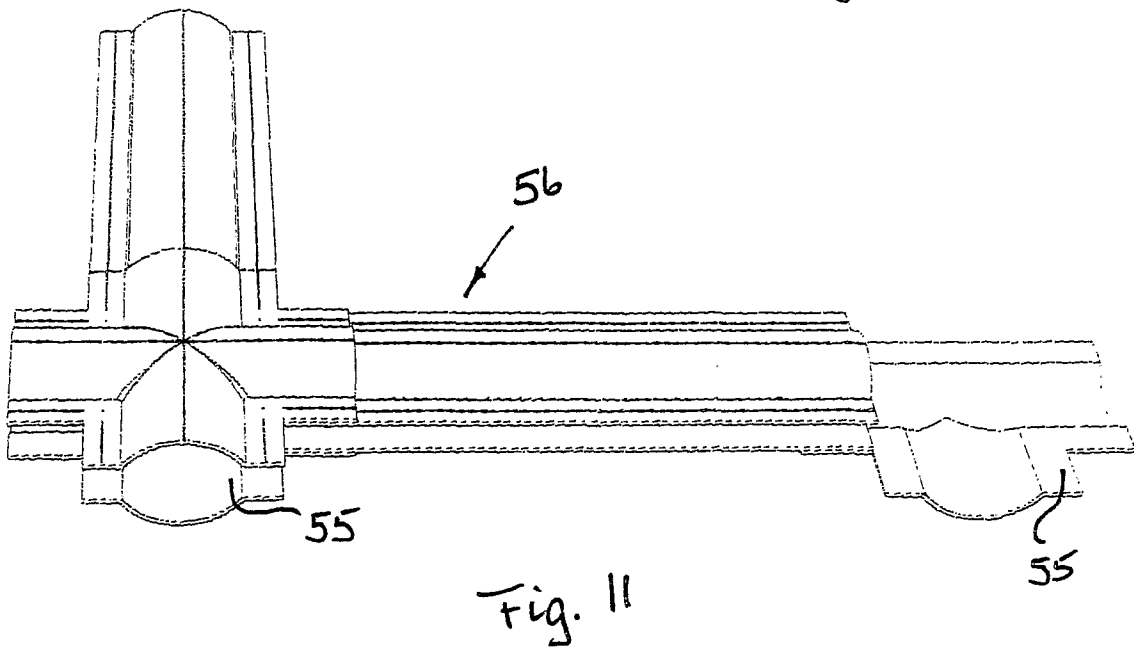
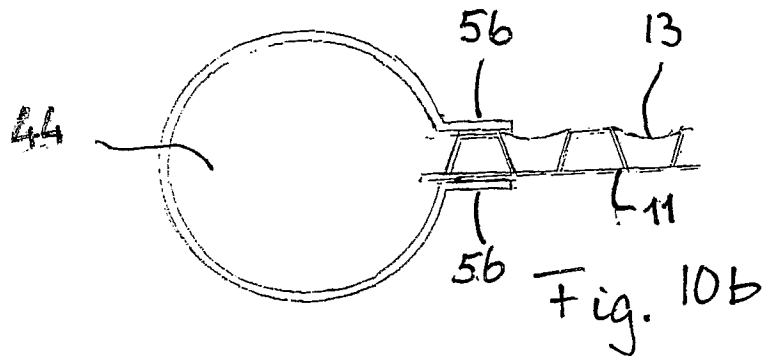
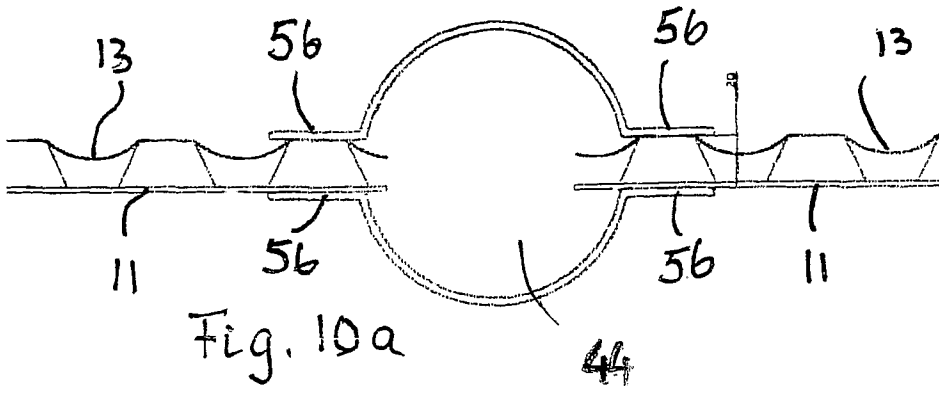

Fig. 9



INTERNATIONAL SEARCH REPORT

International application No.

PCT/NO2008/000443

A. CLASSIFICATION OF SUBJECT MATTER

IPC: see extra sheet

According to International Patent Classification (IPC) or to both national classification and IPC

B. FIELDS SEARCHED

Minimum documentation searched (classification system followed by classification symbols)

IPC: E01C, E02B

Documentation searched other than minimum documentation to the extent that such documents are included in the fields searched

SE,DK,FI,NO classes as above

Electronic data base consulted during the international search (name of data base and, where practicable, search terms used)

EPO-INTERNAL, WPI DATA, PAJ

C. DOCUMENTS CONSIDERED TO BE RELEVANT

Category*	Citation of document, with indication, where appropriate, of the relevant passages	Relevant to claim No.
A	US 4925342 A (HENDY), 15 May 1990 (15.05.1990), whole document --	1-13
A	US 6280117 B1 (OBERMEYER ET AL), 28 August 2001 (28.08.2001), figure 1, abstract --	1-13
A	US 3577894 A (DEAN EMERSON JR.), 11 May 1971 (11.05.1971), column 2, line 53 - column 3, line 15, figures 1,4,5 --	1-13
A	WO 8901076 A1 (MOGFORD, NOEL, PETER, JOHN), 9 February 1989 (09.02.1989), figures 1,2, abstract --	1-13

 Further documents are listed in the continuation of Box C. See patent family annex.

* Special categories of cited documents:

"A" document defining the general state of the art which is not considered to be of particular relevance

"E" earlier application or patent but published on or after the international filing date

"L" document which may throw doubts on priority claim(s) or which is cited to establish the publication date of another citation or other special reason (as specified)

"O" document referring to an oral disclosure, use, exhibition or other means

"P" document published prior to the international filing date but later than the priority date claimed

"T" later document published after the international filing date or priority date and not in conflict with the application but cited to understand the principle or theory underlying the invention

"X" document of particular relevance: the claimed invention cannot be considered novel or cannot be considered to involve an inventive step when the document is taken alone

"Y" document of particular relevance: the claimed invention cannot be considered to involve an inventive step when the document is combined with one or more other such documents, such combination being obvious to a person skilled in the art

"&" document member of the same patent family

Date of the actual completion of the international search

26 March 2009

Date of mailing of the international search report

06-04-2009

Name and mailing address of the ISA/

Swedish Patent Office
Box 5055, S-102 42 STOCKHOLM
Facsimile No. +46 8 666 02 86

Authorized officer

Björn Lindkvist / JA A
Telephone No. +46 8 782 25 00

INTERNATIONAL SEARCH REPORT

International application No.
PCT/NO2008/000443

C (Continuation). DOCUMENTS CONSIDERED TO BE RELEVANT		
Category*	Citation of document, with indication, where appropriate, of the relevant passages	Relevant to claim No.
A	GB 2352954 A (CHARLES LAWRENCE SURFACES PLC), 14 February 2001 (14.02.2001), figure 2, abstract -- -----	1-13

International patent classification (IPC)**E02B 11/00** (2006.01)**E01C 13/02** (2006.01)**E01C 13/08** (2006.01)**Download your patent documents at www.prv.se**

The cited patent documents can be downloaded:

- From "Cited documents" found under our online services at www.prv.se (English version)
- From "Anförda dokument" found under "e-tjänster" at www.prv.se (Swedish version)

Use the application number as username. The password is **HGYVCDWVPD**.

Paper copies can be ordered at a cost of 50 SEK per copy from PRV InterPat (telephone number 08-782 28 85).

Cited literature, if any, will be enclosed in paper form.

INTERNATIONAL SEARCH REPORT
Information on patent family members

International application No.
PCT/NO2008/000443

US	4925342	A	15/05/1990	NONE
US	6280117	B1	28/08/2001	NONE
US	3577894	A	11/05/1971	NONE
WO	8901076	A1	09/02/1989	NONE
GB	2352954	A	14/02/2001	NONE