

(19) **DANMARK**

(10) **DK/EP 3814627 T3**



(12) **Oversættelse af
europæisk patentskrift**

Patent- og
Varemærkestyrelsen

-
- (51) Int.Cl.: **F 03 D 7/02 (2006.01)**
- (45) Oversættelsen bekendtgjort den: **2024-01-02**
- (80) Dato for Den Europæiske Patentmyndigheds bekendtgørelse om meddelelse af patentet: **2023-10-25**
- (86) Europæisk ansøgning nr.: **19731280.4**
- (86) Europæisk indleveringsdag: **2019-06-17**
- (87) Den europæiske ansøgnings publiceringsdag: **2021-05-05**
- (86) International ansøgning nr.: **EP2019065819**
- (87) Internationalt publikationsnr.: **WO2020002014**
- (30) Prioritet: **2018-06-28 DE 102018005134**
- (84) Designerede stater: **AL AT BE BG CH CY CZ DE DK EE ES FI FR GB GR HR HU IE IS IT LI LT LU LV MC MK MT NL NO PL PT RO RS SE SI SK SM TR**
- (73) Patenthaver: **Siemens Gamesa Renewable Energy Service GmbH, Beim Strohause 17-31, 20097 Hamburg, Tyskland**
- (72) Opfinder: **GOSCH-PLESS, Timo, Milower Weg 3a, 24783 Osterröfeld, Tyskland**
WARFEN, Karsten, Lindenstraße 1, 23795 Weede/Söhren, Tyskland
- (74) Fuldmægtig i Danmark: **Novagraaf Brevets, Bâtiment O2, 2 rue Sarah Bernhardt CS90017, F-92665 Asnières-sur-Seine cedex, Frankrig**
- (54) Benævnelse: **FREMGANGSMÅDE OG STYREENHED TIL DRIFT AF EN VINDMØLLE**
- (56) Fremdragne publikationer:
EP-A2- 2 306 005
WO-A1-2015/074664
WO-A1-2015/086023
WO-A1-2017/201460

METHOD AND CONTROLLER FOR OPERATING A WIND TURBINE

Description

The present invention relates to a method and a controller for operating a wind turbine, a wind turbine with the controller, and a computer program product for
5 carrying out the method.

A method for operating a wind turbine is known in DE 10 2015 004 393 A1, in which at least one process variable representing the vibration of a tower of the wind turbine in the transverse direction is detected, an amplification factor is determined on the basis of a vibration intensity that can be determined from the at
10 least one process variable, a manipulated variable is determined on the basis of this amplification factor and the at least one process variable, and a reaction torque, referred to as a rolling torque, of a drive train comprising a rotor, generator, and, if applicable, transmission is influenced on the basis of the determined manipulated variable.

15 Since the rolling moment is supported on the top of the tower, influencing it can change a support force acting upon the top of the tower and thereby dampen lateral vibration of the tower in the transverse direction.

From WO 2015/086023 A1, a method is known in which the angle of incidence of each rotor blade can be controlled when the tower of the turbine is oscillating in a
20 spin in a power generation state, in order to generate active damping with aerodynamic forces, which counteracts the oscillation of the tower.

From WO 2015/074664 A1, a method is known in which the blade angular position of the rotor blades is actively set in order to keep a generator speed at a value which is not zero and is below the nominal value in extreme wind events or
25 extreme wind loads when a wind speed is above the switch-off wind speed.

The object of the present invention is to improve a wind turbine or its operation.

This object is achieved by a method having the features of claim 1. Claims 8-10 provide a controller or a computer program product for carrying out a method

described herein or a wind turbine with a controller described herein. The dependent claims relate to advantageous developments.

According to one embodiment of the present invention, a wind turbine has a tower and a rotor, arranged on a top of the tower in one embodiment of a machine nacelle,
5 with at least one rotor blade, which is adjustable about a blade setting axis.

In one embodiment, the tower is arranged in a body of water, and, in one development, before a coast ("offshore").

In such wind turbines, the present invention can be used to particular advantageous - in particular, due to vibration excitations from the body of water,
10 and in particular shaft loads - without being limited thereto.

In one embodiment, the rotor or the top of the tower, and thus in particular the machine nacelle, is adjusted - in one development, by means of an in particular electrical and/or hydraulic drive - about a tracking axis transversely to its axis of rotation relative to a tower fuselage, and in particular tracks a wind direction, or the
15 wind turbine is for this purpose or correspondingly configured.

Additionally or alternatively, the axis of rotation encloses, in one embodiment, with the direction of gravity, an angle of at least 60°, and in particular at least 70°, in one embodiment, at least 75°, and/or at most 120°, and in particular at most 110°, and in one embodiment, at most 105°, i.e., in one embodiment, at least
20 substantially horizontally.

Additionally or alternatively, the tracking axis encloses, in one embodiment, with the direction of gravity, an angle of at most 30°, and in particular at most 20°, in one embodiment, at most 10°, i.e., in one embodiment, at least substantially vertically.

In addition or alternatively, in one embodiment, the rotor has at least two and/or
25 at most five, in another embodiment, exactly three, rotor blades, each of which can be adjusted about a blade setting axis, in one embodiment, singly or individually, in another embodiment, jointly or synchronously, in one embodiment (in each case), with the aid of a drive, and in particular an electric and/or hydraulic drive. In another embodiment, the rotor has only (precisely) one rotor
30 blade. In this way - in particular, in a combination of two or more of these

features or embodiments - in particular, wind energy can be very advantageously converted into electrical energy.

According to one embodiment of the present invention, a method for operating the wind turbine has a first operating mode in which the rotor blade, or one or more,
5 and preferably all, rotor blades of the rotor have (in each case) one, and in one embodiment, the same, operating angular position about the (respective) blade setting axis, and a wind-power-related or wind-induced rotation of the rotor is converted into electrical energy or power by means of a generator device, which is output and/or stored by the wind turbine in an electrical network.

10 In one embodiment, the generator device has at least one generator that can be (rotationally) coupled or is (rotationally) coupled to the rotor, and/or is arranged in the top of the tower, and in particular the machine nacelle. In one embodiment, the generator device comprises a converter system via which the generator torque can advantageously be freely adjusted within wide limits.

15 In one development, the generator can be coupled or is coupled to the rotor by at least one transmission of the generator device which, in one embodiment, converts a speed of the rotor to a fast(er) speed.

As a result, in one embodiment, wind energy can, very advantageously, be converted into electrical energy.

20 Likewise, the wind turbine can also have a gearless generator device or can convert a rotation of the rotor into electrical energy or power, or can be set up for this purpose without gears.

As a result, the wind turbine can advantageously have fewer (fast) rotating parts and accordingly less wear.

25 In one embodiment, the first operating mode is a partial load mode which, in one embodiment, is carried out at wind speeds in the range of approximately 4 to approximately 12 m/s, or above a switch-on and below a nominal (wind) speed.

Accordingly, in one embodiment, the (respective) rotor blade in the, or its, operating angular position has a so-called pitch or blade setting angle of, at least

substantially, 0° about its blade setting axis, and in particular a fine pitch or optimum blade pitch angle at the optimum high-speed of the rotor, which is equal to the quotient of the product of the rotor rotational speed and the length of the rotor blade from the axis of rotation to the blade tip divided by the wind speed, wherein the optimum blade pitch angle and optimum high speed are defined in each case by the maximum rotor power at a given wind speed, i.e., the maximum power coefficient.

According to one embodiment of the present invention, (at least) one second operating mode is provided in which the rotor blade or one or more, and preferably all rotor blades of the rotor (in each case) is/are, and in particular will be, adjusted or rotated by at least 60° , and in particular at least 70° - in one embodiment, at least 80° , and/or at most 110° , and in particular at most 100° , in one embodiment, at most 95° , and particularly preferably at least 84° and/or at most 94° , about the (respective) blade setting axis into a - in one embodiment, the same - damping angular position, and a counter-torque slowing down the rotor - in particular, in a drive train comprising the rotor and transmission device - is controlled, and in particular modulated, on the basis of or as a function of a vibration of the tower, in particular to reduce this vibration, or in such a way as to reduce, or with the aim of reducing, this vibration of the tower.

As explained in the introduction with reference to DE 10 2015 004 393 A1, a torque caused by the wind power on the rotor ("aerodynamic torque" or "rotor torque" and a counter-torque counteracting this or slowing down the rotor) produces a support force at the top of the tower, so that a vibration of the tower can be reduced or damped by regulating the counter-torque and hence the support force. Reference is also made to the disclosure of DE 10 2015 004 393 A1, and in particular the controller structure and implemented control engineering disclosed therein.

Accordingly, one embodiment of the present invention is based upon the idea of carrying out controlled vibration damping in an operating mode in which the rotor blade or rotor blades are approximately in flag position in which the rotor converts a wind inflow parallel to its rotational axis into a minimum rotational speed.

Such a flag position is usually set either at wind speeds below a switch-on wind speed, which usually lies around 4 m/s, and/or wind speeds above a switch-off speed, which is usually around 25 m/s. In one embodiment, the flag position of a rotor blade in which the rotor converts a wind flow parallel to its axis of rotation into a minimum torque is accordingly rotated by at least 80° and/or at most 100°, and preferably by 90°, against the operating angular position of the rotor blade, which can in one embodiment accordingly also be defined. In one embodiment, in the second operating mode, the rotor blade or blades is or are (respectively) adjusted or rotated from the or their operating angular position in the direction of the or their flag position to the or their damping angular position. In other words, in one embodiment in the second operating mode, the (upstream or wind-struck) front edge of the (respective) rotor blade is turned (into) the (wind) flow from the operating angular position.

Hence, according to one embodiment of the present invention, a vibration of the tower can (also) be advantageously reduced or damped by control engineering at wind speeds below the switch-on wind speed, i.e., in particular, when the rotor is stationary or spinning, and/or above the switch-off speed at which the rotor blade or blades are in approximately the flag position.

Accordingly, in one embodiment, a switch is made from the first to the second operating mode if a wind speed exceeds or detects an - in particular, predetermined - switch-off (wind) speed of the wind turbine, which is adjustable in one embodiment, and in particular detects or predicts using sensors. In one embodiment, the shut-off (wind) speed is at least 20 m/s, in particular at least 23 m/s, and/or at most 35 m/s, and in particular at most 27 m/s. In one embodiment, full-load operation or grid feed-in or an output of electrical power to the electrical grid is terminated if a wind speed exceeds the switch-off (wind) speed or if this is detected, and in particular detected or predicted by sensors; in particular, the switch-off (wind) speed can be defined in such a way that full-load operation or grid feed-in is terminated at this speed.

Additionally or alternatively, in one embodiment, there is a switching from the first to the second operating mode if a malfunction, and in particular a (pre)determined malfunction, is detected.

In one embodiment, the ((pre)determined) malfunction can be a fault of the wind turbine, and in particular a malfunction in its rotor blade adjustment, an exceeding of a permissible operating temperature in a component or a fluid of the wind turbine, or another fault of the wind turbine which does not permit regular
5 (production) operation of the wind turbine, or a ((pre)determined) malfunction can be detected if such a fault is detected.

Additionally or alternatively, in one embodiment, the ((pre)determined) malfunction can be a fault in a or the electrical grid to or in which the wind turbine delivers electrical power, or a ((pre)determined) malfunction can be detected if such a fault
10 is detected. In this case, the term, fault, includes in particular a shutdown due to limited grid feed-in capacities.

Additionally or alternatively, in one embodiment, the ((pre)determined) malfunction can be a fault in a storage device in which the wind turbine stores electrical power, or a ((pre)determined) malfunction can be detected if such a fault is detected.

15 Accordingly, one embodiment of the present invention is based upon the idea of carrying out controlled vibration damping in the event of a fault, wherein the rotor blade or rotor blades are approximately at flag position, and the risk of damage is thus (further) minimized.

In one embodiment, the counter-torque slowing down the rotor is controlled with
20 the aid of the generator device, and in one development in that the braking counter-torque is controlled - in particular, modulated in amplitude, phase, and/or frequency - in such a manner or with the proviso that a supporting force applied by the counter-torque on the top of the tower counteracts or reduces or dampens the vibration to be reduced or damped, and, in one embodiment, as explained above
25 with reference to DE 10 2015 004 393 A1. In a very simple example, the counter-torque can be controlled with the aid of the generator device, e.g., in the event of a (detected) vibration of the tower in one direction, in such a way that the resulting support force applied to the top of the tower acts in the opposite direction, wherein the amount of the support force or the counter-torque can depend upon the
30 vibration, and in particular its vibration amplitude and/or frequency - for example, upon an acceleration of the top of the tower or the like.

Additionally or alternatively, in one embodiment, the counter-torque slowing down the rotor is controlled on the basis of (a signal) of at least one vibration sensor which in one development measures accelerations or is set up or used for this purpose and/or is arranged at between 25 % and 70 %, and in particular between
5 35 % and 65 %, in one embodiment, between 40 % and 60 %, or between 70 % and 100 %, of a tower height between the foundation and the top of the tower and/or in or under a machine nacelle of the tower bearing the rotor.

In simplified terms, the tower can be regarded as a cantilever or bending beam clamped on one side with end mass in the form of the top of the tower, and in
10 particular the machine nacelle, whose first (bending) intrinsic shape has its maximum deflection at the top of the tower, and whose second (bending) intrinsic shape has its maximum deflection in the region of the tower center.

Correspondingly, in one embodiment, vibrations, and in particular a first or second (bending) intrinsic shape or a lateral vibration of the tower transverse to the axis of
15 rotation of the rotor, can be detected very advantageously with the aid of such vibration sensors and thus reduced or damped by control engineering.

In general, the vibration of the tower, which is reduced or damped by control engineering, or on the basis of which or for the reduction or damping of which the counter-torque is controlled, and, in one embodiment, modulated in amplitude,
20 phase, and/or frequency, is a lateral vibration of the tower, and in particular of a first or second intrinsic shape of the tower, and/or transverse to an axis of rotation of the rotor and/or tracking axis of the top of the tower.

Such vibrations can be reduced or damped very advantageously by the present invention without the invention being limited thereto.

25 In one embodiment, the counter-torque slowing down the rotor is controlled to maintain a direction of a (resultant or total) torque driving the rotor or in such a way or with the proviso that a rotational direction or a direction of rotation of a (resultant or total) torque driving the rotor or acting upon the rotor does not change as a result of the control, and in particular a resultant torque or torsional torque acting in
30 the drive train comprising the rotor and generator device does not change sign. In one embodiment, to this end, the amplitude of the torque modulation or of the

counter-torque is lower than the current and/or mean torque applied to or acting upon the rotor - in particular, by more than 10 %, and, in one embodiment, by more than 15 % - or the counter-torque slowing down the rotor is controlled in this way with the aid of the generator device. In a very simple example, the counter-torque can also be reduced when the wind power-related or induced aerodynamic or rotor torque is reduced in order to maintain by control engineering the direction of the total torque acting upon or driving the rotor, or the resulting rotational or torsional torque acting in the drive train comprising the rotor and generator device.

10 In one embodiment, this can advantageously reduce or avoid gear rattling and/or hammering.

In one embodiment, the counter-torque slowing down the rotor is also controlled in the first operating mode on the basis of a or the vibration of the tower, as a result of which loads due to vibrations of the tower can also be advantageously reduced here, and in particular in partial or full-load operation of the wind turbine.

15 In one embodiment, in the second operating mode, a wind-power-related rotation of the rotor is converted into electrical power with the aid of the generator device, which is used to adjust the rotor blade or rotor blades about the (respective) blade setting axis and/or to supply loads - in one embodiment, heating resistors and/or auxiliary units - of the wind turbine, and/or is fed into the electrical grid and/or stored by the wind turbine - in particular, in that the counter-torque slowing down the rotor is at least partially applied or induced by the generator device or generation of electrical power.

25 Since the electrical power generated - in particular, during, or by, or for the regulation of the counter-torque - is used at least partially for adjusting the rotor blade or the rotor blades, in one embodiment, the damping angular position or also the operating angular position can advantageously again be approached. Additionally or alternatively, in one embodiment, the damping angular position can be adapted to any considerable changes in the wind speed.

30 Since the generated electrical power is at least partially output and/or stored in the electrical network, wind energy can advantageously also be used in one embodiment even at substantially flag position. Likewise, as explained above, in

one embodiment in the second operating mode, grid feed-in can also be terminated or omitted.

By using the generated electrical power at least partially for supplying loads of the wind power plant, in one embodiment, the loads can advantageously be supplied,
5 and/or the counter-torque can be advantageously controlled.

In one embodiment, this power output or stored in the second operating mode is at most 2 %, and in one embodiment at most 1 %, of a nominal power of the wind turbine. Additionally or alternatively, in one embodiment in the second operating mode, a rotational speed of the rotor is at most 20 %, and in one embodiment at
10 most 10 %, of a nominal rotational speed of the wind turbine.

Accordingly, one embodiment of the present invention is based upon the idea of carrying out controlled vibration damping even under wind or operating conditions in which the rotor blade or rotor blades are approximately at flag position, so that in particular the risk of damage is (further) minimized.

15 In one embodiment, the rotor or top of the tower, and in particular thus the machine nacelle, is adjusted or rotated about the tracking axis in the first operating mode and/or in the second operating mode as a function of a wind direction, and in particular relative to the tower fuselage and/or in such a way that the axis of rotation of the rotor - in particular, oriented from the rotor towards the generator
20 device or machine nacelle - forms an angle with the wind direction which is at most 45°, in particular at most 30°, in one embodiment, at most 15°, and in particular, at least substantially parallel to the wind direction. In other words, in one embodiment, the rotor or top of the tower, and in particular the machine nacelle, is turned into the wind, or its direction is tracked in the second operating mode.

25 In one embodiment, to this end, the drive for adjusting the rotor or top of the tower, and in particular the machine nacelle, about the tracking axis in the second operating mode is supplied or operated with electrical energy, which is generated with the aid of the generator device for or when regulating the counter-torque.

According to one embodiment of the present invention, a or the control of the wind
30 turbine, and in particular of the wind turbine, is configured and/or has hardware

and/or software, and in particular programming, for carrying out a method described herein:

- a first operating mode or means for performing a first operating mode or operation of the wind turbine in a first operating mode in which the at least one rotor blade has an operating angular position about the blade setting axis, and a rotation of the rotor caused by a wind force is converted with the aid of a generator device (40, 41) into electrical power which is transferred from the wind turbine to an electrical mains (52) and/or stored; and
 - a second operating mode or means for carrying out a second operating mode or operation of the wind turbine in a second operating mode, in which the at least one rotor blade is adjusted by at least 60° and/or by a maximum of 110° about the blade setting axis with respect to the operating angular position into a damping angular position, and a counter-torque which slows down the rotor is controlled with the aid of the generator device on the basis of a vibration of the tower.
- 15 In one embodiment, the controller or its means has:
- means for switching from the first to the second operating mode if a wind speed exceeds a switch-off speed and/or if a malfunction is detected; and/or
 - means for controlling the counter-torque slowing down the rotor on the basis of at least one vibration sensor (11) - arranged, in particular, at between 20 25 % and 70 % or 70 % and 100 % of a tower height and/or in or under an engine nacelle of the tower bearing the rotor - and/or a lateral vibration of the tower, and in particular of a first or second intrinsic shape of the tower and/or transverse to an axis of rotation (R) of the rotor, and/or for maintaining a direction of a torque driving the rotor and/or also in the first operating mode on the basis of a vibration 25 of the tower; and/or
 - means for converting a wind-force-related rotation of the rotor in the second operating mode into electrical power using the generator device, and means for employing this electrical power for adjusting the at least one rotor blade about the blade setting axis and/or for supplying loads of the wind turbine and/or for

outputting this electrical power of the wind turbine into the electrical network and/or storing this electrical power; and/or

- means for adjusting the rotor in the first and/or second operating mode as a function of a wind direction about a tracking axis transversely to its axis of rotation.

- 5 A means in the sense of the present invention can be designed as hardware and/or software, and in particular can have a processing unit - in particular, a microprocessor unit, and in particular at least one CPU, and/or one or more programs or program modules - preferably connected to a memory and/or bus system in terms of data or signals. The processing unit can be designed to
- 10 execute commands that are implemented as a program stored in a memory system, to detect input signals from a data bus, and/or to deliver output signals to a data bus. A storage system can have one or more, and in particular different, storage media - in particular, optical, magnetic, solid-state, and/or other non-volatile media. The program can be designed in such a way that it embodies or is
- 15 capable of carrying out the methods described here, so that the processing unit can carry out the steps of such methods and accordingly, in particular, can control or operate the wind turbine. In one embodiment, a computer program product can have, and in particular be, a storage medium - in particular, non-volatile - for storing a program or having a program stored thereon, wherein execution of said
- 20 program causes a system or a controller, and in particular a computer, to execute a method described herein or one or more of its steps.

In one embodiment, one or more, and in particular all, steps of the method are carried out completely or partially automatically - in particular, by the controller or its means.

- 25 Further advantages and features emerge from the dependent claims and the exemplary embodiments. In this regard, the following are shown partially schematically:

Fig. 1: a wind turbine with a controller for operating the wind turbine according to an embodiment of the present invention; and

Fig. 2: a method for operating the wind turbine according to an embodiment of the present invention.

Fig. 1 shows a wind turbine with a controller 10 for operating the wind turbine according to one embodiment of the present invention with a tower, which has a top of the tower in the form of a machine nacelle 20 and a tower fuselage 21, on
5 which the machine nacelle 20 can be rotated by a drive 22 about a vertical tracking axis N and accordingly can be adjusted to a wind direction, as indicated in Fig. 1 by an adjustment arrow. For this purpose, the controller 10 controls the drive 22, as indicated in Fig. 1 by a control arrow.

10 In the exemplary embodiment, the tower (fuselage 21) is at sea, as indicated by a water surface W.

A rotor having rotor blades 30 is mounted in the machine nacelle 20 so as to be rotatable about an axis of rotation R, as indicated in Fig. 1 by a rotation arrow.

The rotor blades 30 are each rotatable about their blade setting axis B, as
15 indicated in Fig. 1 by adjusting arrows. For this purpose, the controller 10 controls a blade adjustment drive, as indicated in Fig. 1 by a control arrow.

The rotor is coupled via a transmission 40 to a generator 41 of a generator device.

The controller 10 controls a counter-torque slowing down the rotor, which the generator 41 applies during or by converting a rotation of the rotor into electrical
20 energy, which is delivered to loads 50 and/or storage 51 and/or an electrical network 52.

In a method shown in Fig. 2 for operating the wind turbine according to one embodiment of the present invention, in a step S10 or first operating mode in the form of partial load operation, the rotor blades are set to a pitch angle of
25 approximately 0° , and a rotation of the rotor caused by wind force is converted into electrical power by means of the generator device 40, 41, which is output by the wind turbine to the electrical network 52. In full-load operation, the rotor blades are operated with a variable blade pitch angle between 0° and 45° .

If a malfunction of the wind turbine or of the electrical network 52 or a wind speed above a predefined switch-off speed (S20: "Y") is detected, the controller 10 switches into a second operating mode. For this purpose, the rotor blades are rotated by approximately 84° to 94° about their blade adjusting axes in the direction of the flag position, i.e., their front edges (left in Fig. 1) rotated (into) the (wind) inflow (Fig. 2: S30). Otherwise (S20: "N"), the first operating mode is maintained or switched to another operating mode (not shown).

In a step S40 or the second operating mode, the counter-torque applied by the generator device during or by the generation of electrical energy is controlled or modulated such that a lateral vibration of the tower transverse to the axis of rotation R and tracking axis N (perpendicular to the plane of the drawing of Fig. 1) is reduced.

For this purpose, an acceleration sensor 11 detects a lateral acceleration of the top 20 of the tower and transmits a corresponding signal to the controller 10, as indicated in Fig. 1 by a signal arrow.

Based upon this, the latter determines an output variable which can, for example, be proportional to the lateral acceleration which in one embodiment is band-limited, wherein the proportionality factor can in turn depend upon the amount of the lateral acceleration, which in one embodiment is asymmetrically ramp-limited and/or smoothed, and in one embodiment is linear or non-linear and/or limited by an upper and/or lower limit. The output variable, which is phase-shifted by 90° and possibly harmonized, forms a manipulated variable that is used to control the counter-torque applied by the generator device during or as a result of the generation of electrical energy - for example, forming a generator setpoint torque or being superimposed on a desired generator setpoint torque mean value.

The counter-torque is controlled in such a way that a drive train comprising a torsional torque in the rotor and generator device 40, 41 does not change its sign, in order to avoid rattling in the transmission 40.

As long as the malfunction of the wind turbine or the electrical network 52 or a wind speed above a predetermined shutdown (wind) speed is detected (S50: "Y"), step S40 or the second operating mode continues to be executed; otherwise (S50:

"N"), the method or the controller 10 or the wind turbine returns to step S10 or the first operating mode.

PATENTKRAV

1. Fremgangsmåde til drift af et vindenergianlæg, der omfatter et tårn (20-22) og en rotor, som er anbragt i toppen (20) af tårnet og har mindst ét rotorblad (30), der kan indstilles om en bladindstillingsakse (B), hvor:
 - 5 - det mindst ene rotorblad i en første driftsmodus (S10) har en driftsvinkelposition om bladindstillingsaksen, og en rotation af rotoren, der er forårsaget af vindkraft, omdannes til elektrisk strøm ved hjælp af en generatorindretning (40, 41), hvilken elektriske strøm overføres fra vindenergianlægget til et elnet (52) og/eller lagres; og
 - 10 - det mindst ene rotorblad i en anden driftsmodus (S40) indstilles med mindst 60° og/eller med maksimalt 110° om bladindstillingsaksen i forhold til driftsvinkelpositionen til en dæmpningsvinkelposition, og et modmoment, der bremser rotoren, styres ved hjælp af generatorindretningen på basis af en svingning af tårnet.
- 15 2. Fremgangsmåde ifølge krav 1, **kendetegnet ved, at** der udføres et skift fra den første driftsmodus til den anden driftsmodus, i tilfælde af at en vindhastighed overstiger en udkoblingshastighed, og/eller i tilfælde af at der detekteres en funktionsfejl.
 3. Fremgangsmåde ifølge et hvilket som helst af de foregående krav,
20 **kendetegnet ved, at** modmomentet, der bremser rotoren, styres på basis af mindst én svingningssensor (11), især på basis af en svingningssensor (11), der er anbragt ved mellem 25 % og 70 % eller mellem 70 % og 100 % af en tårnhøjde og/eller i eller under en nacelle af tårnet, der understøtter rotoren, og/eller på basis af en lateralsvingning af tårnet, især på basis af en lateralsvingning af en første
25 eller en anden naturlig svingningstype for tårnet og/eller på tværs af en rotationsakse (R) af rotoren og/eller til opretholdelse af en retning af et drejningsmoment, der driver rotoren, og/eller også på basis af en svingning af tårnet i den første driftsmodus.
 4. Fremgangsmåde ifølge et hvilket som helst af de foregående krav,
30 **kendetegnet ved, at** en rotation af rotoren, der er forårsaget af vindkraft, i den

anden driftsmodus omdannes til elektrisk strøm ved hjælp af generatorindretningen, hvilken elektriske strøm anvendes til indstilling af det mindst ene rotorblad om bladindstillingsaksen og/eller til forsyning til vindenergianlæggets elektriske laster (50) og/eller afgives fra vindenergianlægget til elnettet og/eller lagres, hvor den effekt, der afgives eller lagres, udgør maksimalt 2 % af en nominel effekt for vindenergianlægget, og/eller **ved at** en rotationshastighed af rotoren, i den anden driftsmodus, udgør maksimalt 20 % af en nominel hastighed for vindenergianlægget.

5. Fremgangsmåde ifølge et hvilket som helst af de foregående krav, **kendetegnet ved, at** tårnet er anbragt i en vandmasse, og/eller at generatorindretningen har en transmission (40), og/eller rotoren omfatter mindst to rotorblade (30), der hver især kan indstilles om en tilhørende bladindstillingsakse (B), og hver især har en driftsvinkelposition, især den samme driftsvinkelposition, om deres tilhørende bladindstillingsakser i den første driftsmodus, og hver især indstilles med mindst 60° og/eller med maksimalt 110° om deres tilhørende bladindstillingsakser i forhold til driftsvinkelpositionen til en dæmpningsvinkelposition, især den samme dæmpningsvinkelposition, i den anden driftsmodus.

6. Fremgangsmåde ifølge et hvilket som helst af de foregående krav, **kendetegnet ved, at** det mindst ene rotorblad kan indstilles om bladindstillingsaksen, med mindst 80° og/eller med maksimalt 100°, fra driftsvinkelpositionen til en kantstillingsposition, hvor rotoren omdanner en indstrømmende vind parallelt med rotationsaksen til en minimal rotationshastighed.

7. Fremgangsmåde ifølge et hvilket som helst af de foregående krav, **kendetegnet ved, at** rotoren i den første og/eller den anden driftsmodus som funktion af en vindretning indstilles om en sporingsakse (N) på tværs af rotationsaksen.

8. Styreenhed (10) til et vindenergianlæg, hvor vindenergianlægget omfatter et tårn (20-22) og en rotor, der er anbragt i toppen (20) af tårnet, hvor rotoren har mindst ét rotorblad (30), der kan indstilles om en bladindstillingsakse (B), hvor

styreenheden er indrettet med henblik på at udføre en fremgangsmåde ifølge et hvilket som helst af de foregående krav, og/eller hvor styreenheden omfatter:

- en første driftsmodus, hvor det mindst ene rotorblad har en driftsvinkelposition om bladindstillingsaksen, og en rotation af rotoren, der er forårsaget af vindkraft, omdannes til elektrisk strøm ved hjælp af en generatorindretning (40, 41), hvilken elektriske strøm overføres fra vindenergianlægget til et elnet (52) og/eller lagres; og
- en anden driftsmodus, hvor det mindst ene rotorblad indstilles med mindst 60° og/eller med maksimalt 110° om bladindstillingsaksen i forhold til driftsvinkelpositionen til en dæmpningsvinkelposition, og **kendetegnet ved, at** et modmoment, der bremser rotoren, styres ved hjælp af generatorindretningen på basis af en svingning af tårnet.

9. Vindenergianlæg, der omfatter et tårn (20, 21), en rotor med mindst ét rotorblad (30), der kan indstilles om en bladindstillingsakse (B), hvilken rotor er anbragt i toppen af tårnet, især i en nacelle (20), og en styreenhed (10) ifølge det foregående krav.

10. Computerprogramprodukt, der omfatter en programkode, der er lagret på et computerlæsbart medium, til udførelse af en fremgangsmåde ifølge et hvilket som helst af de foregående krav 1 til 7.

Fig. 1

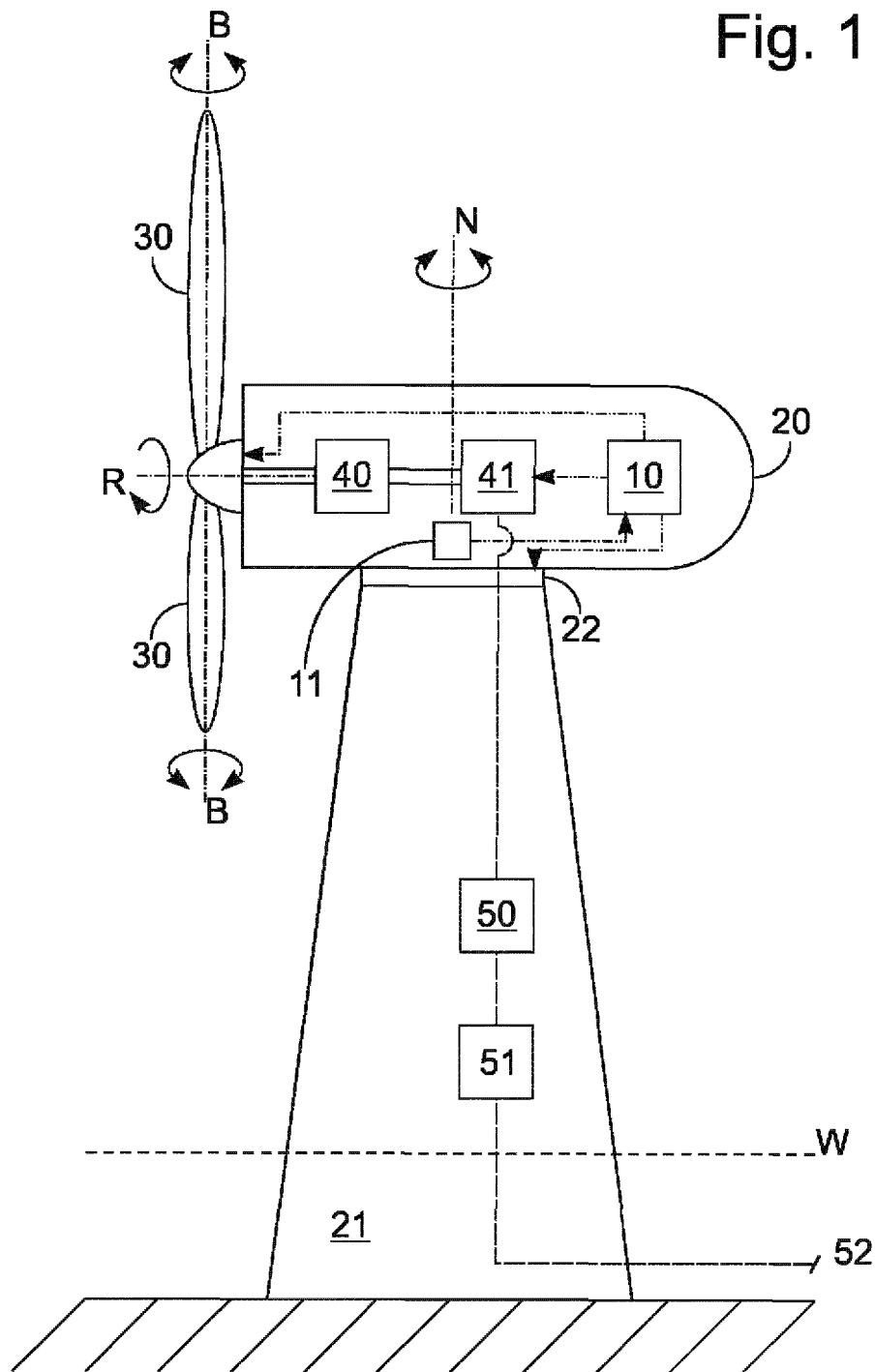

Fig. 2

