

(No Model.)

T. M. WALLACE.
BALE BOX CLAMP.

No. 528,047.

Patented Oct. 23, 1894.

Fig. 1.

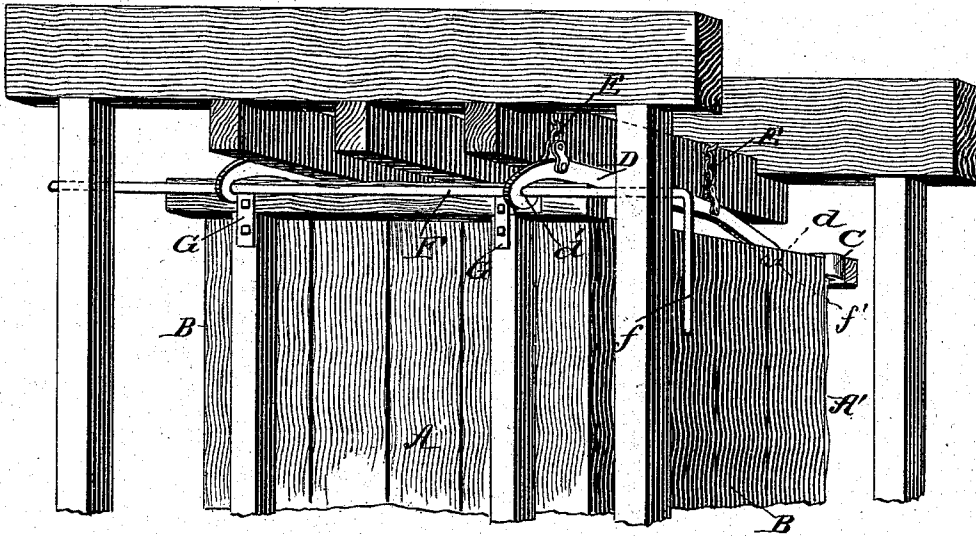
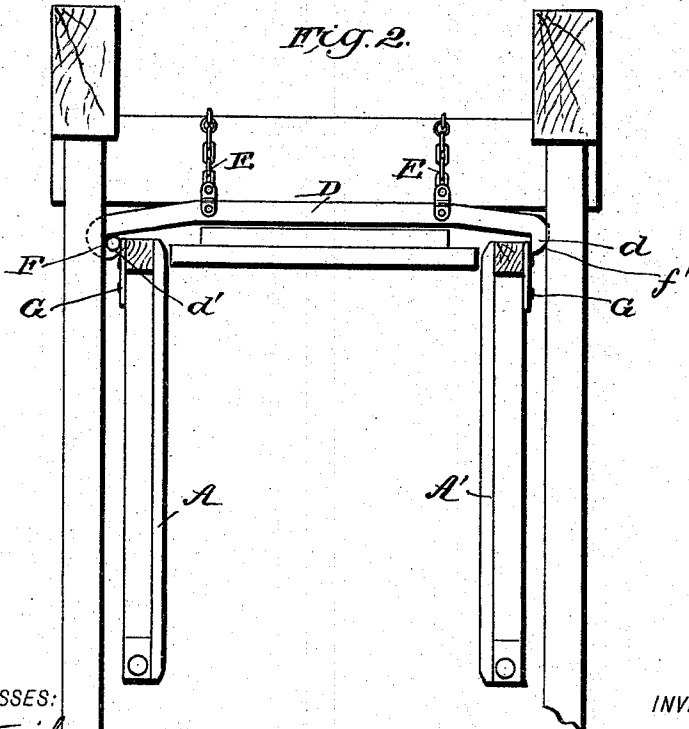

Fig. 2.



WITNESSES:
Fred G. Dietrich
P. B. Surpin

INVENTOR
Thomas M. Wallace
BY *Minna L.*
ATTORNEYS.

UNITED STATES PATENT OFFICE.

THOMAS M. WALLACE, OF MARION, ALABAMA.

BALE-BOX CLAMP.

SPECIFICATION forming part of Letters Patent No. 528,047, dated October 23, 1894.

Application filed January 6, 1894. Serial No. 495,922. (No model.)

To all whom it may concern:

Be it known that I, THOMAS M. WALLACE, of Marion, in the county of Perry and State of Alabama, have invented a new and useful Improvement in Bale-Box Clamps, of which the following is a specification.

My invention is an improvement in bale box clamps and consists in the novel constructions and combinations of parts as will be hereinafter described and pointed out in the claims.

In the drawings—Figure 1 is a perspective view of a bale box provided with my improvements and Fig. 2 is an end view thereof.

The bale box may in general respects be of ordinary construction having the sides A A' and the ends B B, the latter being arranged to engage when the box is closed with lugs C on the inner edges of the sides A' as shown and the said sides and ends are arranged to open outward at their upper ends so that when the clamping devices which hold them closed are released the sides and ends will be opened by the expansion of the bale in the box.

The clamps D of which I preferably use two—one near each end of the box, are suspended above the box preferably upon chains E connecting with said clamps on opposite sides of the center thereof as shown in such manner that the clamps rest above and in position to engage at their ends with the side doors as more fully described hereinafter. To this end I provide the clamps at one end with a catch *d* to engage the side A' while at the other end the clamps are provided with eyes *d'* in which is held the shaft F whose end is provided with a handle *f* by which the shaft may be turned. This shaft rests in the closed position of the box, against plates G provided on the outer side of the side door A and holds such door in place the opposite side door being held by the catches *d*, and these side doors hold the end doors as described. Thus when the clamps and shaft are adjusted as shown in Fig. 1 the side and end doors will be locked in closed position.

To open the box after the bale has been pressed it is only necessary to swing the shaft handle outward when the shaft will roll up and off the plates G of the side door A which will then open by the pressure of the bale in the box. The side door A' will then swing

the clamps to one side or endwise and slightly upward until said door A' is freed from catches *d* when the side doors and the end doors will open leaving the bale free, the clamps remaining suspended in position to again hold the side doors when they are next closed.

In closing the box the end doors are first raised and then the side doors the latter securing the end doors and being in turn secured by the clamps, the latter being formed at the under sides of their ends with inclines *f'* so that the upper edges of the side doors pressing thereagainst will pass automatically into engagement with the clamps as will be readily understood from the drawings.

It will be noticed that the clamps are disconnected from the doors and supported entirely independent thereof so that when the doors are opened the clamps will not in any way interfere with the adjustment of such doors to their extreme lowermost positions. Furthermore the clamps are at all times supported in position to engage the side doors or either of the same whenever they may be lifted to closed position.

In practice the clamps, as a rule, do not rest down upon the side doors when the same are closed in position, but generally swing clear, the upper ends of the chains being preferably supported on vertical hooks with screw and nut at the top by which the height of the clamps may be adjusted so as to fit the doors.

In opening the box the clamps have an endwise movement in the direction of that of door A' and slightly upward on account of the arc movement of the suspended clamps.

By preference I not only incline the under sides of the ends of the clamps but I also bevel the inner edges of the door so that the clamp ends may slip over easier.

Having thus described my invention, what I claim as new, and desire to secure by Letters Patent, is—

1. The combination with the bale box of the clamps suspended above it, having at one end catches to engage one of the side doors and the shaft journaled to the opposite ends of the clamps and bearing in the closed position of the box outside the side door opposite that secured by the clamp catches the suspension of the clamps maintaining the same in con-

venient position for application in use and the journaling of the shaft to said clamps retaining the clamps and shaft in the desired relation all substantially as set forth.

5 2. In combination with the bale box having opposite side doors one of which is provided on its outer side with plates, the clamps supported above said box and having at one end
10 a shaft journaled in them and bearing against said plates and at their other ends catches engaging the opposite side doors substantially as set forth.

15 3. The combination of the bale box end and side doors the latter being arranged to secure the former, the clamps suspended above said box and having at one end catches engaging one of the side doors and the shaft journaled in said clamps and engaging the opposite side door whereby the several parts are main-

tained in convenient position for application 20 to the box and are retained in the desired relation, substantially as set forth.

4. The combination of the bale box, the clamps provided at one end with catches to engage and secure one of the box doors, the 25 shaft journaled in and held to said clamps near their other ends and arranged and adapted to engage and secure the door opposite that held by the end catches of the clamps and supporting devices connected with the 30 clamps and adapted to secure the same entirely independent of the box all substantially as and for the purposes set forth.

THOMAS M. WALLACE.

Witnesses:

W. P. WALTON,
JAS. D. WADE.