

No. 62,788.

PATENTED MAR. 12, 1867.

S. VAN EMON.
HOISTING MACHINE.

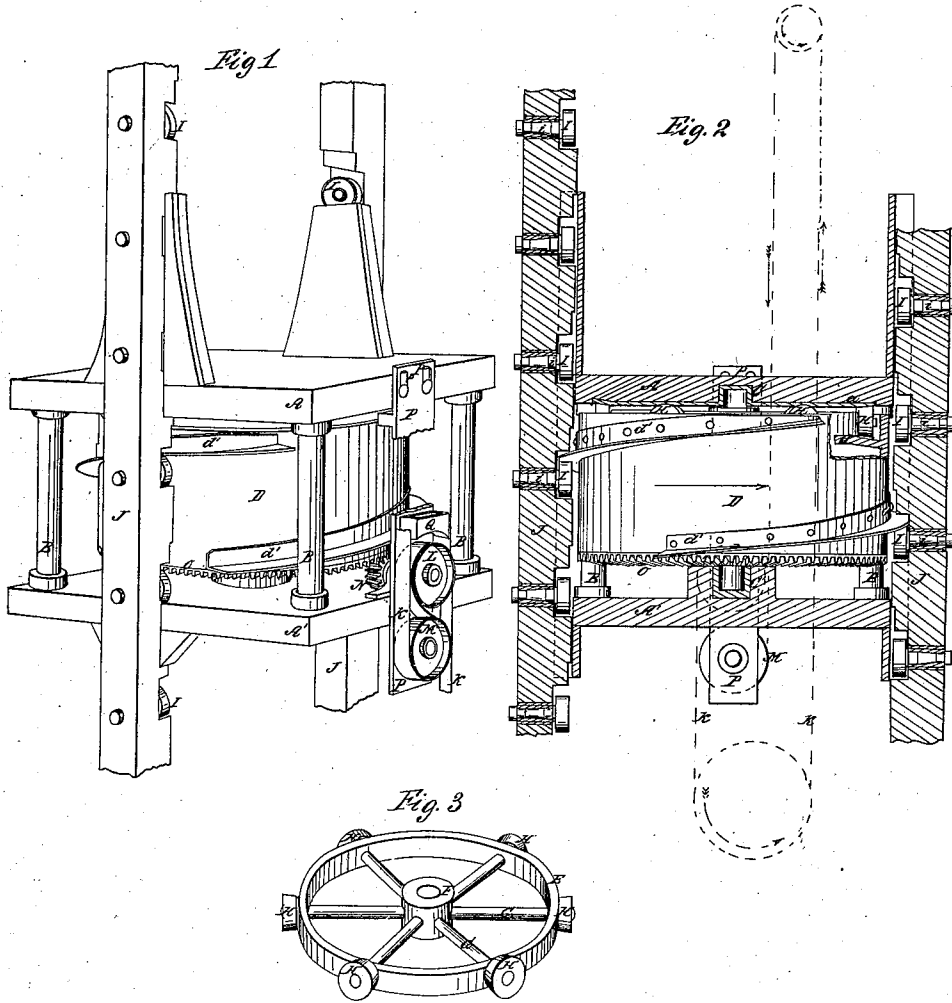

Witnesses:
James H. Layman
P. Hillward

Inventor:
S. Van Emon
By Knight Bros
Atty

United States Patent Office.

SAMUEL VAN EMON, OF CINCINNATI, OHIO.

Letters Patent No. 62,788, dated March 12, 1867.

IMPROVEMENT IN HOISTING MACHINE.

The Schedule referred to in these Letters Patent and making part of the same.

TO ALL WHOM IT MAY CONCERN:

Be it known that I, SAMUEL VAN EMON, of Cincinnati, Hamilton county, and State of Ohio, have invented certain new and useful Improvements in Hoisting Machines; and I do hereby declare the following to be a full, clear, and exact description thereof, reference being had to the accompanying drawings, making part of this specification.

My invention consists in journalling within the hoisting platform a screw or worm of nearly the same size as the hatchways, the worm being so that its threads or flanges may rest on or revolve over a line or series of rollers, or their equivalents, at suitable intervals, in two or more fixed vertical stanchions. In the accompanying drawings—

Figure 1 is a perspective view of the preferred construction of my hoisting apparatus.

Figure 2 is a vertical section of the same; and

Figure 3 is a perspective view of a roller-frame, devised as an anti-friction medium between the weighted platform and the propelling-worm.

The platform-frame, composed, as shown, of floors A A' and posts B, is provided with boxes C C', in which is vertically journalled the propelling-worm or screw D, which is adapted to revolve freely within the frame. To diminish friction, I journal on the shaft of the screw D, between the floor A of the platform-frame and the face *d* of the worm, an anti-friction roller-frame, composed, as shown in fig. 3, of a ring, E, box F, arms G, and rollers H; the rollers bearing, when in position, on the face *d* of the worm, and on the plated bottom *a* of the floor A. As a modification of this device, the rollers may be journalled in fixed boxes on the under side of the floor A, and bear on the face *d* of the worm. The worm D is a mere shell or drum, constructed in the lightest possible form compatible with the requisite strength; the spiral being simply an angle-iron flange *d'* riveted to the periphery of the drum. The angle-iron spiral flange finds a bearing, at opposite sides, on two or more vertical flights or series of rollers, I, made fast on spindles *i*, which, revolving with the rollers, are journalled horizontally in vertical stanchions J; the stanchions being secured to the sides of the hatchways, and provided throughout their entire length with said rollers, at intervals corresponding exactly with the pitch of the spiral. The roller-spindles *i* may be journalled in babbitt-metal boxes firmly embedded in the stanchions. The rollers receive the weight in regular succession in hoisting and lowering. The worm D may be operated by the well-known belt and pulley device, K L M, connected with the pinion N and toothed face O of the worm. In cases where the pitch of the worm D is so great that the platform, in the event of the belt K breaking, would run down under a heavy load, I have devised the following safety apparatus: The pulley M is journalled to a frame, P, capable of vertical motion in the slots *p*, and carrying a weighted brake, Q, adapted to rub on the pulley L when the frame P is not sustained by the tension of the belt on pulley M. In the event of the accidental breaking of the belt, the brake Q falls on the pulley L and prevents, by excessive friction, the revolution of the worm D, and the consequent running down of the platform. In the construction of the worm D and stanchions J, I do not desire to restrict myself to the precise form described, as the worm D may have one or more spirals which may be cast in one piece with the drum, while the rollers I may revolve on studs projecting rigidly from the stanchions, or the stanchions may be provided with common worm racks; but in this case the friction would be so great that its operation would be almost impracticable; moreover, three or more equidistant flights of stanchions and rollers may be employed.

I claim herein as new and of my invention—

1. An elevator platform, provided with a spiral drum or worm, D, in combination with two or more vertical flights of rollers I, arranged and operated as set forth.
2. The provision of the anti-friction roller-frame E F G H, for the purpose specified.
3. The gravitating pulley-frame P and brake Q, operated in the manner and for the purpose specified.

In testimony of which invention I hereunto set my hand.

SAMUEL VAN EMON.

Witnesses:

JAMES H. LAYMAN,
GEO. H. KNIGHT.