

No. 860,239.

PATENTED JULY 16, 1907.

A. PARKER-SMITH.
SLACK ADJUSTER.
APPLICATION FILED NOV. 21, 1906.

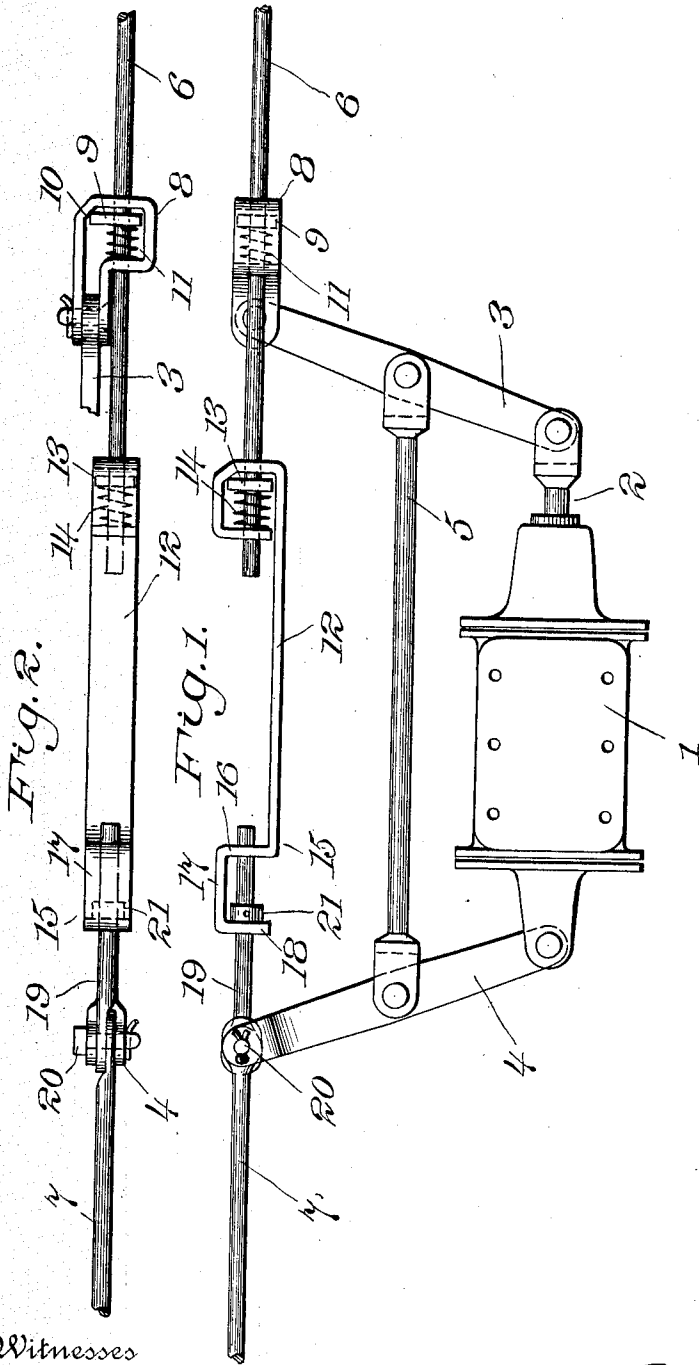

Witnesses
Manuel C. Lopez
M. G. Crawford

Inventor
A. Parker-Smith

UNITED STATES PATENT OFFICE.

AUGUSTUS PARKER-SMITH, OF NEW YORK, N. Y., ASSIGNOR TO ATLAS SLACK ADJUSTER COMPANY, A CORPORATION OF NEW YORK.

SLACK-ADJUSTER.

No. 860,239.

Specification of Letters Patent.

Patented July 16, 1907.

Application filed November 21, 1906. Serial No. 344,432.

To all whom it may concern:

Be it known that I, AUGUSTUS PARKER-SMITH, a citizen of the United States of America, and a resident of the borough of Manhattan, city, county, and State of New York, have invented certain new and useful Improvements in Slack-Adjusters, of which the following is a specification.

My invention relates to mechanism for automatically adjusting the brake rigging on a railway or other car so that uniform maximum travel of the piston will be preserved as the brake shoes wear down.

The best form of apparatus at present known to me embodying my invention is shown in the accompanying drawing in which

Figure 1 is a plan view of a portion of the usual brake rigging with my invention applied thereto, and Fig. 2 is a side elevation of the same with parts broken away.

Throughout the drawings like figures indicate like parts.

1 is the compressed air cylinder, 2 the piston, 3 the right hand brake lever, 4 the left hand brake lever, 5 the tie rod, 6 the right hand top rod and 7 the left hand top rod all of usual construction except that top rod 6 is not pivoted direct to brake lever 3 but passes through the clutch stirrup 8 as shown in Fig. 2. The stirrup 8 is pivoted to the brake lever and contains the perforated clutch dog 9, engaging top rod 6, fulcrumed on the beveled corner 10 of the stirrup and held in operative position by spring 11. The inner end of top rod 6 is grasped by a second, adjustable clutch or other gripping device preferably composed of the stirrup 12, clutch dog 13, and spring 14. An extension 15 of this stirrup has any suitable lost motion connection with the other top rod 7, either directly or through any convenient mechanism. As shown, this lost motion connection consists of the bent portions, 16, 17 and 18 of the stirrup extension 15, the supplementary rod 19 pivoted to the other top rod 7, and to the brake lever 4 by the common pin 20. The portions 16 and 18 of the stirrup extension are perforated to permit the passage of the rod 19 and the projection 21, which is a nut or ring riveted to the rod 19, is located between the two perforated portions of the stirrup extension.

In operation the take-up clutch comprising the stirrup 12 will move with the top rod 6, until excess travel of piston rod 2 occurs. Then portion 16 of the stirrup extension will strike stop 21, and shove clutch dog 13 to the right along top rod 6. On release of brakes stop 21 will strike portion 18 of the stirrup extension and clutch dog 13 will hold top rod 6 while clutch dog 9 is shoved to the right along the top rod a corresponding distance. This will take up the slack. By varying the length of portion 17 of the stirrup extension, or the thickness of stop 21, the permissible piston travel may be varied.

The advantages of my invention comprise its ease of attachment to existing apparatus, cheapness and simplicity and accuracy of action.

Other forms of gripping devices might be substituted for the friction clutches shown and other forms of lost motion connection used, but I believe those illustrated to be the best adapted to the work.

Having, therefore, described my invention, I claim:

1. In a slack adjusting device for railway brakes the combination with the usual brake levers and top rods of an adjustable gripping device pivoted to one brake lever and grasping the corresponding top rod and a second adjustable gripping device also grasping said top rod and having a lost motion connection with the other top rod.

2. In a slack adjusting device for railway brakes the combination with the usual brake levers, and top rods, of a friction clutch pivoted to one brake lever and grasping the corresponding top rod and a second take-up friction clutch also grasping the said top rod and having a lost motion connection with the other top rod.

3. In a slack adjusting device for railway brakes the combination with the usual brake levers and top rods, of a stirrup pivoted to one brake lever perforated for the passage of a top rod and provided with a clutch dog engaging said rod and a second similar stirrup mounted on the inner end of the top rod and having a bent extension, a rod engaging said bent extension and pivoted to the other brake lever, and a projection on said rod limiting the movement over it of the stirrup extension.

Signed at New York, N. Y., this 19th day of November, 1906.

A. PARKER-SMITH.

Witnesses:

MANUEL C. LOPEZ,
M. G. CRAWFORD.