



(22) Date de dépôt/Filing Date: 2020/02/14  
(41) Mise à la disp. pub./Open to Public Insp.: 2020/04/28  
(45) Date de délivrance/Issue Date: 2024/03/12  
(30) Priorités/Priorities: 2019/02/14 (US62/805,521);  
2020/02/13 (US16/790,538)

(51) Cl.Int./Int.Cl. *H02P 27/04* (2016.01),  
*E21B 43/26* (2006.01), *H02K 7/14* (2006.01)

(72) Inventeurs/Inventors:  
FISCHER, JOHN, US;  
CORSETTO, JOHN J., US;  
KUBRICHT, DAVID, US;  
CHEATHAM, RICHARD, US;  
POLLACK, JEFFREY, US;  
LAWMAN, CHAD, US;  
TODD, DAVID, US;  
NOLEN, TYLER, US

(73) Propriétaire/Owner:  
HALLIBURTON ENERGY SERVICES, INC., US

(74) Agent: NORTON ROSE FULBRIGHT CANADA

(54) Titre : REMORQUE DE DISTRIBUTION DE PUISSANCE POUR SYSTEME DE FRACTURATION HYDRAULIQUE A  
COMMANDE ELECTRIQUE

(54) Title: POWER DISTRIBUTION TRAILER FOR AN ELECTRIC DRIVEN HYDRAULIC FRACKING SYSTEM

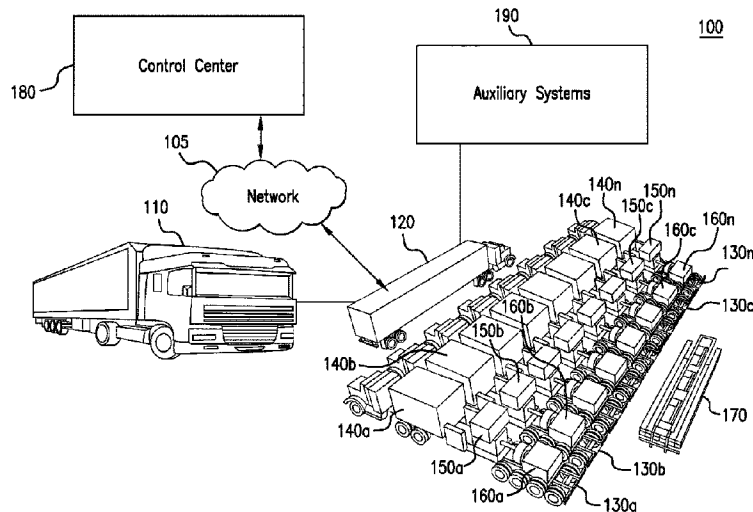

(57) **Abrégé/Abstract:**

An electric driven hydraulic fracturing system is disclosed. A pump configuration that includes the single VFD, the single shaft electric motor, and the single hydraulic pump that is mounted on the single pump trailer. A power distribution trailer distributes the electric power generated by the power generation system at the power generation voltage level to the single VFD and converts the electric power at a power generation voltage level to a VFD voltage level and controls the operation of the single shaft electric motor and the single hydraulic pump. The power distribution trailer converts the electric power generated by the power generation system at the power generation level to an auxiliary voltage level that is less than the power generation voltage level. The power distribution trailer distributes the electric power at the auxiliary voltage level to the single VFD that controls an operation of the of the auxiliary systems.

(74) Agent(suite/continued): LLP/S.E.N.C.R.L., S.R.L.

## ABSTRACT

An electric driven hydraulic fracking system is disclosed. A pump configuration that includes the single VFD, the single shaft electric motor, and the single hydraulic pump that is mounted on the single pump trailer. A power distribution trailer distributes the electric power generated by the power generation system at the power generation voltage level to the single VFD and converts the electric power at a power generation voltage level to a VFD voltage level and controls the operation of the single shaft electric motor and the single hydraulic pump. The power distribution trailer converts the electric power generated by the power generation system at the power generation level to an auxiliary voltage level that is less than the power generation voltage level. The power distribution trailer distributes the electric power at the auxiliary voltage level to the single VFD that controls an operation of the of the auxiliary systems.

# POWER DISTRIBUTION TRAILER FOR AN ELECTRIC DRIVEN HYDRAULIC FRACKING SYSTEM

## BACKGROUND

### Related Application(s)

**[0001]** This application claims the benefit of U.S. Provisional Application No. 62/805,521 filed on February 14, 2019.

### Field of Disclosure

**[0002]** The present disclosure generally relates to electric driven hydraulic fracking systems and specifically to a single Variable Frequency Drive (VFD), a single shaft electric motor, and a single hydraulic pump positioned on a single pump trailer.

### Related Art

**[0003]** Conventional hydraulic fracking systems are diesel powered in that several different diesel engines apply the power to the hydraulic pumps as well as several types of auxiliary systems that assist the hydraulic pumps to execute the fracking, such as hydraulic coolers and lube pumps. Conventional diesel powered hydraulic fracking systems require a diesel engine and a transmission to be connected to a hydraulic pump to drive the hydraulic pump. However, typically several hydraulic pumps are required at a single fracking site to prepare the well for the later extraction of the fluid, such as hydrocarbons, from the existing well. Thus, each of the several hydraulic pumps positioned at a single fracking site require a single diesel engine and single transmission to adequately drive the corresponding hydraulic pump requiring several diesel engines and transmissions to also be positioned at the single fracking site in addition to the several hydraulic pumps.

**[0004]** Typically, the diesel engines limit the horsepower (HP) that the hydraulic pumps may operate thereby requiring an increased quantity of hydraulic pumps to attain the required HP necessary prepare the well for the later extraction of fluid, such as hydrocarbons, from the existing well. Any increase in the power rating of hydraulic pumps also results in an increase in the power rating of diesel engines and transmissions required at the fracking site as each hydraulic pump requires a sufficiently rated diesel engine and transmission. As the diesel

engines, transmissions, and hydraulic pumps for a single fracking site increase, so does quantity of trailers required to transport and position configurations at the fracking site.

**[0005]** The numerous diesel engines, transmissions, and hydraulic pumps required at a fracking site significantly drives up the cost of the fracking operation. Each of the numerous trailers required to transport and position configurations require CDL drivers to operate as well as increased manpower to rig the increased assets positioned at the fracking site and may be classified as loads in need of permits, thus adding expense and possible delays. The amount of diesel fuel required to power the numerous diesel engines to drive the numerous hydraulic pumps required to prepare the well for the later extraction of the fluid, such as hydrocarbons, from the existing well also significantly drives up the cost of the fracking operation. Further, the parasitic losses typically occur as the diesel engines drive the hydraulic pumps as well as drive the auxiliary systems. Such parasitic losses actually decrease the amount of HP that is available for the hydraulic pumps operate thereby significantly decreasing the productivity of hydraulic pumps. In doing so, the duration of the fracking operation is extended resulting in significant increases in the cost of the fracking operation. The diesel engines also significantly increase the noise levels of the fracking operation and may have difficulty operating within required air quality limits.

### **BRIEF DESCRIPTION OF THE DRAWINGS/FIGURES**

**[0006]** Embodiments of the present disclosure are described with reference to the accompanying drawings. In the drawings, like reference numerals indicate identical or functionally similar elements. Additionally, the left most digit(s) of a reference number typically identifies the drawing in which the reference number first appears.

**[0007]** FIG. 1 illustrates a top-elevational view of a hydraulic fracking operation such that the hydraulic pumps may pump a fracking media into a fracking well to execute a fracking operation to extract a fluid from the fracking well;

**[0008]** FIG. 2 illustrates a top-elevational view of a single pump configuration that includes a single VFD, a single shaft electric motor, and a single hydraulic pump that are each mounted on a single pump trailer;

**[0009]** FIG. 3 illustrates a block diagram of an electric driven hydraulic fracking system that provides an electric driven system to execute a fracking operation in that the electric power

is consolidated in a power generation system and then distributed such that each component in the electric driven hydraulic fracking system is electrically powered;

**[0010]** FIG. 4 illustrates a block diagram of an electric driven hydraulic fracking system that further describes the incorporation of the power distribution trailer into the electric driven hydraulic fracking system;

**[0011]** FIG. 5 illustrates a block diagram of an of an electric driven hydraulic fracking system that further describes the incorporation of the power distribution trailer into the electric driven hydraulic fracking system;

**[0012]** FIG. 6 illustrates a top-elevational view of a connector configuration for each of the VFDs that may couple to a medium voltage cable, a low voltage cable, and a communication cable.

#### **DETAILED DESCRIPTION OF THE PRESENT DISCLOSURE**

**[0013]** The following Detailed Description refers to accompanying drawings to illustrate exemplary embodiments consistent with the present disclosure. References in the Detailed Description to “one exemplary embodiment,” an “exemplary embodiment,” an “example exemplary embodiment,” etc., indicate the exemplary embodiment described may include a particular feature, structure, or characteristic, but every exemplary embodiment may not necessarily include the particular feature, structure, or characteristic. Moreover, such phrases are not necessarily referring to the same exemplary embodiment. Further, when a particular feature, structure, or characteristic may be described in connection with an exemplary embodiment, it is within the knowledge of those skilled in the art(s) to effect such feature, structure, or characteristic in connection with other exemplary embodiments whether or not explicitly described.

**[0014]** The exemplary embodiments described herein are provided for illustrative purposes, and are not limiting. Other exemplary embodiments are possible, and modifications may be made to the exemplary embodiments within the spirit and scope of the present disclosure. Therefore, the Detailed Description is not meant to limit the present disclosure. Rather, the scope of the present disclosure is defined only in accordance with the following claims and their equivalents.

**[0015]** Embodiments of the present disclosure may be implemented in hardware, firmware, software, or any combination thereof. Embodiments of the present disclosure may also be implemented as instructions applied by a machine-readable medium, which may be read and executed by one or more processors. A machine-readable medium may include any mechanism for storing or transmitting information in a form readable by a machine (e.g., a computing device). For example, a machine-readable medium may include read only memory (“ROM”), random access memory (“RAM”), magnetic disk storage media, optical storage media, flash memory devices, electrical optical, acoustical or other forms of propagated signals (e.g., carrier waves, infrared signals, digital signals, etc.), and others. Further firmware, software routines, and instructions may be described herein as performing certain actions. However, it should be appreciated that such descriptions are merely for convenience and that such actions in fact result from computing devices, processors, controllers, or other devices executing the firmware, software, routines, instructions, etc.

**[0016]** For purposes of this discussion, each of the various components discussed may be considered a module, and the term “module” shall be understood to include at least one software, firmware, and hardware (such as one or more circuit, microchip, or device, or any combination thereof), and any combination thereof. In addition, it will be understood that each module may include one, or more than one, component within an actual device, and each component that forms a part of the described module may function either cooperatively or independently from any other component forming a part of the module. Conversely, multiple modules described herein may represent a single component within an actual device. Further, components within a module may be in a single device or distributed among multiple devices in a wired or wireless manner.

**[0017]** The following Detailed Description of the exemplary embodiments will so fully reveal the general nature of the present disclosure that others can, by applying knowledge of those skilled in the relevant art(s), readily modify and/or adapt for various applications such exemplary embodiments, without undue experimentation, without departing from the spirit and scope of the present disclosure. Therefore, such adaptations and modifications are intended to be within the meaning and plurality of equivalents of the exemplary embodiments based upon the teaching and guidance presented herein. It is to be understood that the phraseology or terminology herein for the purpose of description and not of limitation, such that the

terminology or phraseology of the present specification is to be interpreted by those skilled in the relevant art(s) in light of the teachings herein.

### SYSTEM OVERVIEW

**[0018]** FIG. 1 illustrates a top-elevational view of a hydraulic fracking operation such that the hydraulic pumps may pump a fracking media into a well to execute a fracking operation to extract a fluid from the well. A hydraulic fracking operation 100 includes a fracking trailer 170 that a fracking configuration may be deployed. The fracking configuration may be the fracking equipment that executes the actual fracking to prepare the well for the later extraction of the fluid from the well. For example, the fracking trailer 170 may include the fracking equipment that implements the missile as well as the well heads that are affixed onto the well and distribute the fracking media into the well to prepare the well for later extraction of the fluid from the well. The fluid extracted from the well may include a liquid, such as crude oil, and so on, or a gas, such as such as hydrocarbons, natural gas and so on, that is extracted from the well that is then stored and distributed.

**[0019]** The power that is generated to provide power to each of the numerous components included in the hydraulic fracking operation 100 is positioned on a power generation system 110. Often times, the fracking site is a remote site where it has been determined that sufficient fluid has been located underground to justify temporarily establishing the hydraulic fracking operation 100 for a period of time to drill the well and extract the fluid from the well. Such fracking sites are often times positioned in remote locations such as uninhabited areas in mountainous regions with limited road access to the fracking sites such that the hydraulic fracking operation 100 is often times a mobile operation where each of the components are positioned on trailers that are then hauled to the fracking site via semi-trucks and/or tractors. For example, the fracking trailer 170 includes the fracking equipment which is hauled in via a semi-truck and is positioned closest to the well as compared to the other components in order to execute the fracking operation.

**[0020]** In another example, the power generation system 110 may also be a mobile operation such that the power generation equipment may be mounted on a power generation trailer and transported to the fracking site via a semi-truck and/or tractor. The power generation system 110 may be positioned on the fracking site such that any component of the hydraulic

fracking operation 100 may be powered by the power generation system 110. In doing so, the power required for the hydraulic fracking operation 100 may be consolidated to the power generation system 110 such that the power generation system 110 provides the necessary power required for the hydraulic fracking operation 100. Thus, the power generation system 110 may be positioned at the fracking site in a manner such that each component of the hydraulic fracking operation 100 may have power distributed from the power generation system 110 to each respective component of the hydraulic fracking operation 100.

**[0021]** The power generation system 110 may include power generation systems that generate electric power such that the hydraulic fracking operation 100 is powered via electric power generated by the power generation system 110 and does not require subsidiary power generation systems such as subsidiary power generation systems that include diesel engines. In doing so, the power generation system 110 may provide electric power to each component of the hydraulic fracking operation 100 such that the hydraulic fracking operation 100 is solely powered by electric power generated by the power generation system 110. The power generation system 110 may consolidate the electric power that is generated for the electric driven hydraulic fracking system 100 such that the quantity and size of power sources included in the power generation system 110 is decreased.

**[0022]** The power sources are included in the power generation system 110 and output electric power such that the electric power outputted from each power source included in the power generation system 110 is collectively accumulated to be electric power at a power generation voltage level as will be discussed in detail below. For example, the power output for each of the power sources included in the power generation system 110 may be paralleled to generate the electric power at the power generation voltage level. The power generation system 110 may include numerous power sources as well as different power sources and any combination thereof. For example, the power generation system may include power sources that include a quantity of gas turbine engines. In another example, the power generation system 110 may include a power source that includes an electric power plant that independently generates electric power for an electric utility grid. In another example, the power generation system 110 may include a combination of gas turbine engines and an electric power plant. The power generation system 110 may generate the electric power at a power level and a voltage level.

**[0023]** The power generation system 110 may generate electric power at a power generation voltage level in which the power generation voltage level is the voltage level that the power generation system is capable of generating the electric power. For example, the power generation system 110 when the power sources of the power generation system 110 include a quantity of gas turbine engines may generate the electric power at the power generation voltage level of 13.8kV which is a typical voltage level for electric power generated by gas turbine engines. In another example, the power generation system 110 when the power sources of the power generation system include an electric power plant may generate the electric power at the power generation voltage level of 12.47kV which is a typical voltage level for electric power generated by an electric power plant.

**[0024]** In another example, the power generation system 110 may generate electric power that is already at a VFD voltage level to power the single shaft electric motor 150(a-n) as discussed in detail below. In such an example, the power generation system 110 may generate the electric power that is already at the VFD voltage level of 4160V. In another example, the power generation system 110 may generate the electric power at the power generation voltage level at a range of 4160V to 15kV. In another example, the power generation system 110 may generate electric power at the power generation voltage level of up to 38kV. The power generation system 110 may generate the electric power at any power generation voltage level that is provided by the power sources included in the power generation system 110 that will be apparent to those skilled in the relevant art(s) without departing from the spirit and scope of the disclosure. The power generation system 110 may then provide the electric power at the power generation voltage level to the power distribution trailer 120 via a medium voltage cable.

**[0025]** In an embodiment, the power generation system 110 may generate electric power at a power level of at least 24 Mega Watts (MW) that is generated at a power generation voltage level of at least 13.8kV. In another embodiment, the power generation system 110 may generate electric power at a power level of at least 24MW that is generated at a power generation voltage level of at least 12.47kV. The power generation system 110 may generate electric power at a power level such that there is sufficient electric power to adequately power each of the components of the hydraulic fracking operation 100 while having gas turbine engines in quantity and in size that enable the gas turbine engines to be transported to the fracking site and set up remotely via a trailer. In doing so, the power distribution trailer 110

may include gas turbine engines that generate sufficient electric power to adequately power each of the components of the hydraulic fracking operation 100 while not requiring a large quantity of gas turbine engines and gas turbine engines of significant size that may significantly increase the difficulty and the cost to transport the gas turbine engines to the fracking site.

**[0026]** In order to provide sufficient electric power to adequately power each of the components of the hydraulic fracking operation 100 while not requiring large quantities of gas turbine engines and/or gas turbine engines of significant size, the power distribution trailer 110 may include single or multiple gas turbine engines that generate electric power at power levels of 5MW, 12 MW, 16MW, 20-25MW, 30MW and/or any other wattage level that may not require large quantities of gas turbine engines and/or gas turbine engines of significant size that will be apparent to those skilled in the relevant art(s) without departing from the spirit and scope of the disclosure. In another example, the power generation system 110 may be the electric utility power plant that is local to the location of the fracking operation such that the power distribution trailer 120 may receive the electric power at the power level of 24MW and the power generation voltage level of 12.47kV directly from the electric utility power plant.

**[0027]** In an embodiment, the power generation system 110 may include a first gas turbine engine that generates electric power at a first power level in range of 12MW to 16MW and a second gas turbine engine that generates electric power at a second power level in a range of 12MW to 16MW. The first gas turbine engine and the second gas turbine engine generate the same voltage level of at least 13.8kV that is provided to a power distribution trailer 120 when the first power level is in the range of 12MW to 16MW generated by the first gas turbine engine is combined with the second power level in the range of 12MW to 16MW. In order to provide sufficient electric power to adequately power each component of the hydraulic fracking operation 100 as well as limit the quantity of gas turbine engines as well as the size of the gas turbine engines such that the gas turbine engines may be positioned on a single trailer and transported to the fracking site, the power generation system 110 may include two electric gas turbine engines that generate electric power at power levels in the range of 12MW to 16MW such that the electric powers at the power levels in the range of 12MW to 16MW may be paralleled together to generate the total electric power that is available to power each of the components of the hydraulic fracking operation 100 is in the range of 24MW to 32MW.

**[0028]** Further, the power generation system 110 including more than one gas turbine engine to generate the electric power provides redundancy in the power generation for the hydraulic fracking operation 100. In doing so, the power generation system 110 provides a redundancy to the electric driven hydraulic fracking system in that the first gas turbine engine continues to provide the first power level to the power distribution trailer 120 when the second gas turbine engine suffers a short circuit and/or other shutdown condition and the second gas turbine engine continues to provide the second power level to the power distribution trailer 120 when the first gas turbine engine suffers the short circuit and/or other shutdown condition. The power generation system 110 may then maintain a reduced quantity of hydraulic pump(s) 160(a-n) to continuously operate in the continuous duty cycle without interruption in continuously pumping the fracking media due to the redundancy provided by the first gas turbine engine and the second gas turbine engine.

**[0029]** By incorporating two gas turbine engines that generate electric power at power levels in the range of 12MW to 16MW redundancy may be provided in that the electric power that is provided to the components of the hydraulic fracking operation 100 such that the fracking media is continuously pumped into the well to execute the fracking operation to prepare the well for the later extraction of the fluid from the well despite one of the gas turbine engines suffering a short circuit condition. In doing so, the incident energy at the point where the short circuit occurs may be reduced due to the reduced short circuit availability of the power generation system 110. However, if one of the gas turbine engines were to fail due to a short circuit condition, the remaining gas turbine engine may continue to provide sufficient power to ensure the fracking media is continuously pumped into the well. A failure to continuously pump the fracking media into the well may result in the sand, which is a major component of the fracking media coming out of the suspension and creating a plug at the bottom of the well which typically results in a significant expense to remove the sand in the well so that the fracking can continue. The power generation system 110 may include any combination of gas turbine engines and/or single gas turbine engine at any power level to sufficiently generate electric power to adequately power each of the components of the hydraulic fracking operation 100 that will be apparent to those skilled in the relevant art(s) without departing from the spirit and scope of the disclosure.

**[0030]** The power generation system 110 may generate the electric power at a power generation voltage level that is in the medium voltage range of 1.0 kilo Volts (kV) to 72.0kV. However, in an embodiment, the power generation system 110 may generate the electric power at the power generation voltage level of 13.8kV. In another embodiment, the power generation system 110 may generate the electric power at the power generation voltage level of 13.8kV. The generation of the electric power at the voltage level in the medium voltage range enables medium voltage cables to be used to connect the power generation system 110 to the power distribution trailer 120 to propagate the electric power from the power generation system 110 to the power distribution trailer 120 as well as enabling the use of medium voltage cables to propagate the electric voltage level to any of the components powered by the electric power in the medium voltage range. The use of medium voltage cables rather than the use of low voltage cables decreases the size of the cable required in that medium voltage cables require less copper than low voltage cables thereby reducing the size and/or quantity of the cables required for the distribution of power throughout the hydraulic fracking operation 100.

**[0031]** Further, the consolidation of gas turbine engines to decrease the quantity of gas turbine engines required to power the components of the hydraulic fracking operation 100 and/or the incorporation of the electric utility power plant also consolidates the quantity of medium voltage cables that are required to connect each of the gas turbine engines to the power distribution trailer 120 thereby further reducing the cost of the cables required for the hydraulic fracking operation 100. Further, the power generation system 110 generated the electric power at the power generation voltage level of 13.8kV and/or 12.47kV enables the hydraulic fracking operation 100 to be more easily integrated with any electric utility grid anywhere in the world such that the electric utility grid may be more easily substituted into the power generation system 110 in replacement of the gas turbine engines since it is more common that the electric utility grid has transformers available to deliver the electric power at the power generation voltage level of 13.8kV and/or 12.47kV.

**[0032]** The power distribution trailer 120 may distribute the electric power at the power level generated by the power generation system 110 to each variable frequency drive (VFD) 140(a-n) positioned on each pump trailer 130(a-n). As noted above, the power generation system 110 may include at least one gas turbine engine, the electric utility grid, and/or a combination thereof, to generate the electric power. In doing so, a medium voltage power

cable may be connected from each component of the power generation system 110 to the power distribution trailer 120. For example, the power generation system 110 may include two gas turbine engines with each of the gas turbine engines generating electric power at the power level of 12MW to 16MW at the voltage level of 13.8kV. In such an example, two medium voltage cables may then connect each of the two gas turbine engines to the power distribution trailer 120 such that the electric power at the power level of 12MW to 16MW at the voltage level of 13.8kV may propagate from the gas turbine engines to the power distribution trailer 120.

**[0033]** The power distribution trailer 120 may then distribute the electric power to each of the VFDs 140(a-n) positioned on each of the pump trailers 130(a-n). As will be discussed in detail below, several different hydraulic pumps 160(a-n) may be required to continuously pump the fracking media into the well to execute the fracking operation to prepare the well for the later extraction of the fluid from the well. In doing so, each of the different hydraulic pumps 160(a-n) may be driven by a corresponding VFD 140(a-n) also positioned on the corresponding pump trailer 130(a-n) with the hydraulic pump 160(a-n). Each of the VFDs 140(a-n) may then provide the appropriate power to drive each of the single shaft electric motors 150(a-n) that then drive each of the hydraulic pumps 160(a-n) to continuously pump the fracking media into the well to execute the fracking operation to prepare the well for the later extraction of the fluid from the well. Thus, the power distribution trailer 120 may distribute the electric power generated by the power distribution trailer 110 which is consolidated to reduce the quantity of the gas turbine engines to the several different VFDs 140(a-n) positioned on each of the pump trailers 130(a-n). The components of the power distribution trailer 120 may be transported to the fracking site.

**[0034]** For example, the power distribution trailer 120 is configured to distribute the electric power at the power level of at least 24MW generated by the at least one gas turbine engine from the voltage level of at least 13.8kV to the single VFD 140a positioned on the single pump trailer 130a. In such an example, the power generation system 110 includes two different gas turbine engines that generate the electric power at the power level of 12MW to 16MW and at the voltage level of 13.8kV. Two different medium voltage cables may then propagate the electric power generated by each of the two gas turbine engines at the power level of 12MW to 16MW and at the voltage level of 13.8kV to the power distribution trailer

120. The power distribution trailer 120 may then combine the power levels of 12MW to 16MW generated by each of the two gas turbine engines to generate a power level of 24MW to 32MW at the voltage level of 13.8kV. The power distribution trailer 120 may then distribute the electric power at the voltage level of 13.8kV to each of eight different VFDs 140(a-n) via eight different medium voltage cables that propagate the electric power at the voltage level of 13.8kV from the power distribution trailer 120 to each of the eight different VFDs 140(a-n). The power distribution trailer 120 may distribute the power generated by any quantity of gas turbine engines to any quantity of VFDs that will be apparent to those skilled in the relevant art(s) without departing from the spirit and scope of the disclosure.

**[0035]** In an embodiment, the power distribution trailer 120 may include a plurality of switch gear modules in that each switch gear module switches the electric power generated by each of the components of the power generation system 110 and received by the corresponding medium voltage cable to the medium voltage cable on and off to each of the corresponding VFDs 140(a-n). For example, the power distribution trailer 120 may include eight different switch gear modules to independently switch the electric power generated by the two gas turbine engines at the medium voltage level of 13.8kV as received by the two different medium voltage cables on and off to the eight different medium voltage cables for each of the eight corresponding VFDs 140(a-n) to distribute the electric power at the medium voltage level of 13.8kV to each of the eight corresponding VFDs 140(a-n).

**[0036]** In such an embodiment, the switch gear modules may include a solid state insulated switch gear (2SIS) that is manufactured by ABB and/or Schneider Electric. Such medium voltage switch gears may be sealed and/or shielded such that there is no exposure to live medium voltage components. Often times the fracking site generates an immense amount of dust and debris so removing any environmental exposure to live medium voltage components as provided by the 2SIS gear may decrease the maintenance required for the 2SIS. Further, the 2SIS may be permanently set to distribute the electric power from each of the gas turbine engines to each of the different VFDs 140(a-n) with little maintenance. The power distribution trailer 120 may incorporate any type of switch gear and/or switch gear configuration to adequately distribute the electric power from the power generation system 110 to each of the different VFDs 140(a-n) that will be apparent to those skilled in the relevant art(s) without departing from the spirit and scope of the disclosure.

**[0037]** As noted above, the power distribution trailer 120 may distribute the electric power at the power generation voltage level generated by the power generation system 110 to each of the different VFDs 140(a-n) positioned on the corresponding pump trailer 130(a-n). FIG. 2 illustrates a top-elevational view of a single pump configuration 200 that includes a single VFD 240, a single shaft electric motor 250 and a single hydraulic pump 260 that are each mounted on a single pump trailer 230. The single pump configuration 200 shares many similar features with each pump trailer 130(a-n) that includes each corresponding VFD 140(a-n), single shaft electric motor 150(a-n), and single hydraulic pump 160(a-n) depicted in the hydraulic fracking operation 100; therefore, only the differences between the single pump configuration 200 and the hydraulic fracking operation 100 are to be discussed in further details.

**[0038]** The power distribution trailer 120 may distribute the electric power at the voltage level generated by the power generation system 110 to the single VFD 240 that is positioned on the single pump trailer 130(a-n). The single VFD 240 may then drive the single shaft electric motor 250 and the single hydraulic pump 260 as well as control the operation of the single shaft electric motor 250 and the single hydraulic pump 260 as the single shaft electric motor 250 continuously drives the single hydraulic pump 260 as the single hydraulic pump 260 continuously pumps the fracking media into the well to execute the fracking operation to prepare the well for the later extraction of the fluid from the well. In doing so, the VFD 240 may convert the electric power distributed by the power distribution trailer 120 at the power generation voltage level generated by the power generation system 110 to a VFD voltage level that is a voltage level that is adequate to drive the single shaft electric motor 250. Often times, the power generation voltage level of the electric power distributed by the power distribution trailer 120 as generated by the power generation system 110 may be at a voltage level that is significantly higher than a voltage level that is adequate to drive the single shaft electric motor 250. Thus, the single VFD 240 may convert the power generation voltage level of the electric power as distributed by the power distribution trailer 120 to significantly lower (or higher) the voltage level to the VFD voltage level that is needed to drive the single shaft electric motor 250. In an embodiment, the single VFD 240 may convert the power generation voltage level of the electric power as distributed by the power distribution trailer 120 to the VFD voltage level of at least 4160V. In another embodiment, the single VFD 240 may convert the power generation voltage level of the electric power as distributed by the power distribution trailer

120 to the VFD voltage level that ranges from 4160V to 6600V. In another embodiment, the single VFD 240 may convert the power generation level of the electric power as distributed by the power distribution trailer 120 to the VFD voltage level that ranges from 0V to 4160V.

**[0039]** For example, the power generation system 110 generates the electric power at a power generation voltage level of 13.8kV. The power distribution trailer 120 then distributes the electric power at the power generation voltage level of 13.8kV to the single VFD 240. However, the single shaft electric motor 250 operates at a rated voltage level of at least 4160V in order to drive the single hydraulic pump 260 in which the rated voltage level of at least 4160V for the single shaft electric motor 250 to operate is significantly less than the power generation voltage level of 13.8kV of the electric power that is distributed by the power distribution trailer 120 to the single VFD 240. The single VFD 240 may then convert the electric power at the power generation voltage level of at least 13.8kV distributed from the power distribution trailer 120 to a VFD rated voltage level of at least 4160V and drive the single shaft electric motor 250 that is positioned on the single pump trailer 230 at the VFD rated voltage level of at least 4160V to control the operation of the single shaft electric motor 250 and the single hydraulic pump 260. The single VFD 240 may convert any voltage level of the electric power distributed by the power distribution trailer 120 to any VFD voltage level that is adequate to drive the single shaft electric motor that will be apparent to those skilled in the relevant art(s) without departing from the spirit and scope of the disclosure.

**[0040]** The single VFD 240 may also control the operation of the single shaft electric motor 250 and the single hydraulic pump 260. The single VFD 240 may include a sophisticated control system that may control in real-time the operation of the single shaft electric motor 250 and the single hydraulic pump 260 in order for the single shaft electric motor 250 and the single hydraulic pump 260 to adequately operate to continuously pump the fracking media into the well to execute the fracking operation to prepare the well for the later extraction of the fluid from the well. Although, the single shaft electric motor 250 and the single hydraulic pump 260 may operate continuously to continuously pump the fracking media into the well, such continuous operation may not be continuously executed with the same parameters throughout the continuous operation. The parameters in which the single shaft electric motor 250 and the single hydraulic pump 260 may continuously operate may actually vary based on the current state of the fracking operation. The single VFD 240 may automatically adjust the parameters

in which the single shaft electric motor 250 and the single hydraulic pump continuously operate to adequately respond to the current state of the fracking operation.

**[0041]** As noted above, the single VFD 240 may convert the electric power at the power generation voltage level distributed by the power distribution trailer 120 to the VFD voltage level that is adequate to drive the single shaft electric motor 250. The single shaft electric motor 250 may be a single shaft electric motor in that the single shaft of the electric motor is coupled to the single hydraulic pump 260 such that the single shaft electric motor 250 drives a single hydraulic pump in the single hydraulic pump 260. The single shaft electric motor 250 may continuously drive the single hydraulic pump 260 at an operating frequency to enable the single hydraulic pump 260 to continuously pump the fracking media into the well to execute the fracking operation to prepare the well for the later extraction of the fluid from the well. The single shaft electric motor 250 may operate at the VFD voltage levels and at the operating frequencies below or above the rated levels in order to rotate at a RPM level that is appropriate to continuously drive the single hydraulic pump 260 at the maximum horsepower (HP) level that the single hydraulic pump 260 is rated to pump. In an embodiment, the single shaft electric motor 250 may operate at a VFD voltage level of at least 4160V. In an embodiment, the single shaft electric motor 250 may operate at a VFD voltage level in a range of 4160V to 6600V. In an embodiment, the single shaft electric motor 250 may operate at a VFD voltage level in arrange of 0V to 4160V. The single shaft electric motor 250 may operate any VFD voltage level that is adequate to continuously drive the single hydraulic pump 260 that will be apparent to those skilled in the relevant art(s) without departing from the spirit and scope of the disclosure.

**[0042]** For example, the power distribution trailer 120 may distribute the electric power to the single VFD 240 at the power generation voltage level of 13.8kV. The single VFD 240 may then convert the electric power at the power generation voltage level of 13.8kV to the VFD voltage level of 4160V to adequately drive the single shaft electric motor 250. The single shaft electric motor 250 may operate at an operating frequency of 60Hz and when the VFD voltage level of 4160V to adequately drive the single shaft electric motor at the operating frequency of 60Hz, the single shaft electric motor 250 may then rotate at a RPM level of at least 750RPM. The single shaft electric motor 250 may rotate at a RPM level of at least 750RPM based on the VFD voltage level of at least 4160V as provided by the single VFD 240 and to drive the single

hydraulic pump 260 that is positioned on the single pump trailer 230 with the single VFD 240 and the single shaft electric motor 250 with the rotation at the RPM level of at least 750RPM.

**[0043]** In an embodiment, the single shaft electric motor 250 may rotate at a RPM level of at least 750RPM. In an embodiment, the single shaft electric motor 250 may rotate at a RPM level of 750RPM to 1400RPM. The single shaft electric motor 250 may operate at any RPM level to continuously drive the single hydraulic pump 260 that will be apparent to those skilled in the relevant art(s) without departing from the spirit and scope of the disclosure. The single shaft electric motor may operate at any operating frequency to continuously drive the single hydraulic pump 260 that will be apparent to those skilled in the relevant art(s) without departing from the spirit and scope of the disclosure.

**[0044]** The single shaft electric motor 250 may be an induction motor that rotates at the RPM level needed to obtain required pump speed based on the input gear box ratio of the single hydraulic pump 260. Based on the operating frequency of the single shaft motor 250 and the VFD voltage level applied to the single shaft electric motor 250, the single shaft electric motor 250 may then rotate at the required RPM level and produce sufficient torque to cause the pump to produce the required flow rate of fracking media at the required output pressure level. However, the VFD voltage level applied to the single shaft electric motor 250 may be determined based on the input gear box ratio of the single hydraulic pump 260 as the single shaft electric motor 250 cannot be allowed to rotate at the RPM level that exceeds the maximum speed rating of the input gear box of the single hydraulic pump 260 or the maximum speed of the single hydraulic pump 260. The single shaft electric motor 250 may be an induction motor, a traction motor, a permanent magnet motor and/or any other electric motor that continuously drives the single hydraulic pup 260 that will be apparent to those skilled in the relevant art(s) without departing from the spirit and scope of the disclosure.

**[0045]** As noted above, the single shaft electric motor 250 may be coupled to a single hydraulic pump in the single hydraulic pump 260 and drive the single hydraulic pump 260 such that the single hydraulic pump 260 continuously pumps the fracking media into the well to execute the fracking operation to prepare the well for the later extraction of the fluid from the existing well. The single hydraulic pump 260 may operate on a continuous duty cycle such that the single hydraulic pump 260 continuously pumps the fracking media into the well. Rather than operating on an intermittent duty cycle that causes conventional hydraulic pumps

to temporarily stall in the pumping of the fracking media into the well, the single hydraulic pump 260 in operating on a continuous duty cycle may continuously pump the fracking media into the well without any intermittent stalling in the pumping. In doing so, the efficiency in the fracking operation to prepare the well for the later extraction of the fluid from the well may significantly increase as any intermittent stalling in pumping the fracking media into the well may result in setbacks in the fracking operation and may increase the risk of sand plugging the existing well. Thus, the single hydraulic pump 260 in operating on the continuous duty cycle may prevent any setbacks in the fracking operation due to the continuous pumping of the fracking media into the well.

**[0046]** The single hydraulic pump 260 may continuously pump the fracking media into the well at the HP level that the single hydraulic pump 260 is rated. The increase in the HP level that the single hydraulic pump 260 may continuously pump the fracking media into the well may result in the increase in the efficiency in the fracking operation to prepare the well for later extraction of the fluid from the well. For example, the single hydraulic pump 260 may continuously pump the fracking media into the well at the HP level of at least 5000HP as driven by the single shaft motor 250 at the RPM level of at least 750RPM. The single hydraulic pump 260 operates on a continuous duty cycle to continuously pump the fracking media at the HP level of at least 5000HP. In an embodiment, the single hydraulic pump 260 may operate at continuous duty with a HP level of 5000HP and may be a Weir QEM5000 Pump. However, the single hydraulic pump 260 may any type of hydraulic pump that operates on a continuous duty cycle and at any HP level that adequately continuously pumps the pumping fracking media into the well to execute the fracking operation to prepare the well for the later extraction of the fluid from the well that will be apparent to those skilled in the relevant art(s) without departing from the spirit and scope of the disclosure.

**[0047]** The single pump trailer 230 discussed in detail above may then be incorporated into the hydraulic fracking operation 100 depicted in FIG. 1. Each of the several pumps trailers 130(a-n), where n is an integer equal to or greater than one, may be in incorporated into the hydraulic fracking operation 100 to increase the overall HP level that is applied to the fracking equipment positioned on the fracking trailer 170 by each of the single hydraulic pumps 160(a-n) positioned on each of the pump trailers 130(a-n). In doing so, the overall HP level that is applied to the fracking equipment positioned on the fracking trailer 170 to continuously pump

the fracking media into the well may be significantly increased as the HP level that is applied to the fracking equipment is scaled with each single hydraulic pump 160(a-n) that is added to the hydraulic fracking operation 100.

**[0048]** The positioning of each single VFD 140(a-n), single shaft electric motor 150(a-n), and each single hydraulic pump 160(a-n) positioned on each corresponding pump trailer 130(a-n) enables the power distribution trailer 120 to distribute the electric power at the power generation voltage level to each single VFD 140(a-n) from a single power distribution source rather than having a corresponding single power distribution source for each single VFD 140(a-n), single shaft electric motor 150(a-n), and each single hydraulic pump 160(a-n). In doing so, the electric power at the power generation voltage level may be distributed to each single VFD 140(a-n), where n is in an integer equal to or greater than one and corresponds to the number of pump trailers 130(a-n), then each single VFD 140(a-n) may individually convert the power generation voltage level to the appropriate VFD voltage for the single shaft electric motor 150(a-n) and the single hydraulic pump 160(a-n) that is positioned on the corresponding pump trailer 130(a-n) with the single VFD 140(a-n). The single VFD 140(a-n) may then also control the corresponding single shaft electric motor 150(a-n) and the single hydraulic pump 160(a-n) that is positioned on the corresponding pump trailer 130(a-n) with the single VFD 140(a-n).

**[0049]** In isolating the single VFD 140(a-n) to convert the electric power at the power generation voltage level to the appropriate VFD voltage level for the single shaft electric motor 150(a-n) and the single hydraulic pump 160(a-n) positioned on the corresponding single pump trailer 130(a-n) as the single VFD 140(a-n), the capabilities of the single pump trailer 130(a-n) may then be easily scaled by replicating the single pump trailer 130(a-n) into several different pump trailers 130(a-n). In scaling the single pump trailer 130(a-n) into several different pump trailers 130(a-n), the parameters for the single VFD 140(a-n), the single shaft electric motor 150(a-n), and the single hydraulic pump 160(a-n) may be replicated to generate the several different pump trailers 130(a-n) and in doing so scaling the hydraulic fracking operation 100.

**[0050]** In doing so, each single VFD 140(a-n) may convert the electric power at the power generation voltage level as distributed by the power distribution trailer 120 to the VFD voltage level to drive each single shaft electric motor 150(a-n), where n is an integer equal to or greater than one and corresponds to the quantity of single VFDs 140(a-n) and pump trailers 130(a-n),

such that each single shaft electric motor 150(a-n) rotates at the RPM level sufficient to continuously drive the single hydraulic pump 160(a-n) at the HP level of the single hydraulic pump 160(a-n). Rather than simply having a single hydraulic pump 260 as depicted in FIG. 2 and discussed in detail above to continuously pump at the HP level of the single hydraulic pump 260, several different hydraulic pumps 160(a-n), where n is an integer equal to or greater than one and corresponds to the to the quantity of single VFDs 140(a-n), single shaft electric motors 150(a-n) and pump trailers 130(a-n), as positioned on different pump trailers 160 may be scaled together to scale the overall HP level that is provided to the fracking equipment as positioned on the fracking trailer 170. In doing so, the overall HP level that is provided to the fracking equipment to continuously pump the fracking media into the well to execute the fracking operation to prepare the well for the later extraction of the fluid from the well may be easily scaled by incorporating each of the individual pump trailers 130(a-n) each with single hydraulic pumps 160(a-n) operating at the HP levels to scale the HP levels of the single hydraulic pumps 160(a-n) to generate the overall HP level for the hydraulic fracking operation 100.

**[0051]** For example, each of the single hydraulic pumps 160(a-n) positioned on each corresponding pump trailer 130(a-n) may be operating on a continuous duty cycle at a HP level of at least 5000HP. A total of eight pump trailers 130(a-n) each with a single hydraulic pump 160(a-n) positioned on the corresponding pump trailer 130(a-n) results in a total of eight hydraulic pumps 160(a-n) operating on a continuous duty cycle at a HP level of at least 5000HP. In doing so, each of the eight hydraulic pumps 160(a-n) continuously pump the fracking media into the well at a HP level of at least 40,000HP and do so continuously with each of the eight hydraulic pumps 160(a-n) operating on a continuous duty cycle. Thus, the fracking media may be continuously pumped into the well at a HP level of at least 40,000HP to execute the fracking operation to prepare the well for the later extraction of the fluid from the well. The hydraulic pumps 160(a-n) positioned on each corresponding pump trailer 130(a-n) may operate on a continuous duty at any HP level and the and the quantity of pump trailers may be scaled to any quantity obtain an overall HP level for the hydraulic fracking operation 100 that will be apparent to those skilled in the relevant art(s) without departing from the spirit and scope of the disclosure.

**[0052]** Further, conventional hydraulic fracking operations that incorporate diesel engines require a diesel engine to drive each conventional hydraulic pump rather than being able to consolidate the power generation to a power generation system 110 that consolidates the quantity and size of the gas turbine engines to generate the electric power. Such an increase in diesel engines significantly increases the cost of the fracking operation in that significantly more trailers and/or significantly over size/weight trailers are required to transport the diesel engines resulting in significantly more and/or specialized semi-trucks and/or trailers required to transport the diesel engines which requires significantly more CDL drivers. As the overall asset count increases at the fracking site, the overall cost increases due to the increased amount of manpower required, the costs and delays related to permitted loads, as well as an increase in the amount of rigging that is required to rig each of the diesel engines to the conventional hydraulic pumps and so on. Rather, the electric driven hydraulic fracking operation 100 decreases the asset count by consolidating the power generation to the gas turbine engines of decreased size and quantity that are consolidated into the power generation system 110. The power distribution trailer 120 then further decreases the cost by consolidating the medium voltage cabling that is required to power each of the assets thereby decreasing the amount of rigging required.

**[0053]** Further, conventional hydraulic fracking operations that incorporate diesel engines suffer significant parasitic losses throughout the different components included in the fracking operation. Diesel engines that generate at a power level equal to the rated power level of the conventional fracking pumps may not result in delivering the full rated power to the pump due to parasitic losses throughout the conventional diesel fracking trailer configuration. For example, the diesel engines may suffer parasitic losses when driving the hydraulic coolers and the lube pumps that are associated with the conventional hydraulic pump in addition to the parasitic losses suffered from driving the conventional hydraulic pump itself. In such an example, the diesel engine may be driving the conventional hydraulic pump that is rated at 2500HP at the HP level of 2500HP but due to parasitic losses, the diesel engine is actually only driving the conventional hydraulic pump at 85% of the HP level of 2500HP due to the parasitic losses. However, the electric driven hydraulic fracking operation 100 may have the single hydraulic pump 160(a-n) that is rated at the HP level of 5000HP, however, the parasitic loads are controlled by equipment running in parallel with the single hydraulic pump 160(a-n), thus

the single VFD 140(a-n) associated with each corresponding single hydraulic pump 160(a-n) provides all of its output electric power to the single hydraulic pump 160(a-n), the single hydraulic pump 160(a-n) actually continuously pumps the fracking media into the well at 5000HP. Thus, the asset count required for the electric driven hydraulic fracking operation 100 is significantly reduced as compared to the hydraulic fracking operations that incorporate diesel engines due to the lack of parasitic losses for the electric driven hydraulic fracking operation 100.

**[0054]** Further, the conventional hydraulic fracking operations that incorporate diesel engines generate significantly more noise than the electric driven hydraulic fracking operation 100. The numerous diesel engines required in the conventional hydraulic fracking operations generate increased noise levels in that the diesel engines generate noise levels at 110DbA. However, the gas turbine engines incorporated into the power generation system 110 of the electric driven hydraulic fracking operation 100 generate noise levels that are less than 85DbA. Often times, the fracking site has noise regulations associated with the fracking site in that the noise levels of the fracking operation cannot exceed 85DbA. In such situations, an increased cost is associated with the conventional hydraulic fracking operations that incorporate diesel engines in attempts to lower the noise levels generated by the diesel engines to below 85DbA or having to build sound walls to redirect the noise in order to achieve noise levels below 85DbA. The electric driven fracking operation 100 does not have the increased cost as the noise levels of the oilfield gas turbine engines include silencers and stacks, thus they already fall below 85DbA.

**[0055]** Further, the increase in the quantity of conventional hydraulic pumps further increases the asset count which increases the cost as well as the cost of operation of the increase in quantity of conventional hydraulic pumps. Rather than having eight single hydraulic pumps 160(a-n) rated at the HP level of 5000HP to obtain a total HP level of 40000HP for the fracking site, the conventional hydraulic fracking systems require sixteen conventional hydraulic pumps rated at the HP level of 2500HP to obtain the total HP level of 40000HP. In doing so, a significant cost is associated with the increased quantity of conventional hydraulic pumps. Further, conventional hydraulic pumps that fail to incorporate a single VFD 140(a-n), a single shaft electric motor 150(a-n), and a single hydraulic pump 160(a-n) onto a single pump trailer 130(a-n) further increase the cost by increasing additional trailers and rigging required to set

up the numerous different components at the fracking site. Rather, the electric driven hydraulic fracking operation 100 incorporates the power distribution trailer 120 to consolidate the power generated by the power generation system 110 and then limit the distribution and the cabling required to distribute the electric power to each of the single pump trailers 130(a-n).

**[0056]** In addition to the fracking equipment positioned on the fracking trailer 170 that is electrically driven by the electric power generated by the power generation system 110 and each of the VFDs 140(a-n), single shaft electric motors 150(a-n), and the single hydraulic pumps 160(a-n) that are also electrically driven by the electric power generated by the power generation system 110, a plurality of auxiliary systems 190 may be positioned at the fracking site may also be electrically driven by the electric power generated by power generation system 110. The auxiliary systems 190 may assist each of the single hydraulic pumps 160(a-n) as well as the fracking equipment positioned on the fracking trailer 170 as each of the hydraulic pumps 160(a-n) operate to execute the fracking operation to prepare the well for the later extraction of the fluid from the well. In doing so, the auxiliary systems 190 may be systems in addition to the fracking equipment positioned on the fracking trailer 170 and the single hydraulic pumps 160(a-n) that are required to prepare the well for the later execution of the fluid from the well.

**[0057]** For example, the auxiliary systems 190, such as a hydration system that provides adequate hydration to fracking media as the single hydraulic pumps 160(a-n) continuously pump the fracking media into the well. Thus, auxiliary systems 190 may include but are not limited to hydration systems, chemical additive systems, blending systems, sand storage and transporting systems, mixing systems and/or any other type of system that is required at the fracking site that is addition to the fracking equipment positioned on the fracking trailer 170 and the single hydraulic pumps 160(a-n) that may be electrically driven by the electric power generated by the power generation system 110 that will be apparent to those skilled in the relevant art(s) without departing from the spirit and scope of the disclosure.

**[0058]** The electric power generated by the power generation system 110 may thus be distributed by the power distribution trailer 120 such that the electric power generated by the power generation system 110 may also be incorporated to power the auxiliary systems 190. In doing so, the electric power generated by the power generation system 110 may be incorporated to not only drive the pump trailers 130(a-n) via the single VFDs 140(a-n) positioned on each pump trailer 130(a-n) but to also power the auxiliary systems 190. Thus,

the hydraulic fracking operation 100 may be completely electric driven in that each of the required systems positioned on the fracking site may be powered by the electric power generated by the electric power that is consolidated to the power generation system 110.

**[0059]** As noted above, each of the single VFDs 140(a-n) may include a sophisticated control system that may control in real-time the operation of the single shaft electric motors 150(a-n) and the single hydraulic pumps 160(a-n) in order for the single shaft electric motors 150(a-n) and the single hydraulic pumps 160(a-n) to optimally operate to continuously pump the fracking media into the well to execute the fracking operation to prepare the well for the later extraction of the fluid from the well. However, the fracking control center 180 that may be positioned at the fracking site and/or remote from the fracking site may also control the single VFDs 140(a-n) and in doing so control the real-time operation of the single shaft electric motors 150(a-n) and the single hydraulic pumps 160(a-n) in order for the single shaft electric motors 150(a-n) and the single hydraulic pumps 160(a-n) to optimally operate to continuously pump the fracking media into the well to execute the fracking operation to extract the fluid from the well. In doing so, the fracking control center 180 may intervene to control the single VFDs 140(a-n) when necessary. The fracking control center 180 may also control the fracking equipment positioned on the fracking trailer 170 as well as the auxiliary systems 190 in order to ensure that the fracking operation is optimally executed to prepare the well for the later extraction of the fluid from the well.

**[0060]** Communication between the fracking control center 180 and the single VFDs 140(a-n), the fracking equipment positioned on the fracking trailer 170, and/or the auxiliary systems 190 may occur via wireless and/or wired connection communication. Wireless communication may occur via one or more networks 105 such as the internet or Wi-Fi wireless access points (WAP). In some embodiments, the network 105 may include one or more wide area networks (WAN) or local area networks (LAN). The network may utilize one or more network technologies such as Ethernet, Fast Ethernet, Gigabit Ethernet, virtual private network (VPN), remote VPN access, a variant of IEEE 802.11 standard such as Wi-Fi, and the like. Communication over the network 105 takes place using one or more network communication protocols including reliable streaming protocols such as transmission control protocol (TCP), Ethernet, Modbus, CanBus, EtherCAT, ProfiNET, and/or any other type of network communication protocol that will be apparent from those skilled in the relevant art(s) without

departing from the spirit and scope of the present disclosure. Wired connection communication may occur but is not limited to a fiber optic connection, a coaxial cable connection, a copper cable connection, and/or any other type of direct wired connection that will be apparent from those skilled in the relevant art(s) without departing from the spirit and scope of the present disclosure. These examples are illustrative and not intended to limit the present disclosure.

### ELECTRIC POWER DISTRIBUTION AND CONTROL

**[0061]** FIG. 3 illustrates a block diagram of an electric driven hydraulic fracking system that provides an electric driven system to execute a fracking operation in that the electric power is consolidated in a power generation system and then distributed such that each component in the electric driven hydraulic fracking system is electrically powered. An electric driven hydraulic fracking system 300 includes a power generation system 310, a power distribution trailer 320, a plurality of pump trailers 330(a-n), a plurality of single VFDs 340(a-n), a switchgear configuration 305, a plurality of trailer auxiliary systems 315(a-n), a plurality of switchgears 325(a-n), a switchgear transformer configuration 335, and fracking equipment 370. The electric power is consolidated in the power generation system 310 and then distributed at the appropriate voltage levels by the power distribution trailer 320 to decrease the medium voltage cabling required to distribute the electric power. The single VFDs 340(a-n) and the trailer auxiliary systems 315(a-n) positioned on the pump trailers 330(a-n) as well as the fracking control center 380 and auxiliary systems 390 are electrically powered by the electric power that is consolidated and generated by the power generation system 310. The electric driven hydraulic fracking system 300 shares many similar features with the hydraulic fracking operation 100 and the single pump configuration 200; therefore, only the differences between the electric driven hydraulic fracking system 300 and the hydraulic fracking operation 100 and single pump configuration 200 are to be discussed in further detail.

**[0062]** As noted above, the power generation system 310 may consolidate the electric power 350 that is generated for the electric driven hydraulic fracking system 300 such that the quantity and size of the power sources included in the power generation system 310 is decreased. As discussed above, the power generating system 310 may include numerous power sources as well as different power sources and any combination thereof. For example,

the power generating system 310 may include power sources that include a quantity of gas turbine engines. In another example, the power generation system 310 may include a power source that includes an electric power plant that independently generates electric power for an electric utility grid. In another example, the power generation system 310 may include a combination of gas turbine engines and an electric power plant. The power generation system 310 may generate the electric power 350 at a power level and a voltage level.

**[0063]** The power generation system 310 may generate electric power at a power generation voltage level in which the power generation voltage level is the voltage level that the power generation system is capable of generating the electric power 350. For example, the power generation system 310 when the power sources of the power generation system 310 include a quantity of gas turbine engines may generate the electric power 350 at the voltage level of 13.8kV which is a typical voltage level for electric power 350 generated by gas turbine engines. In another example, the power generation system 310 when the power sources of the power generation system include an electric power plant may generate the electric power 350 at the voltage level of 12.47kV which is a typical voltage level for electric power 350 generated by an electric power plant. The power generation system may generate the electric power 350 at any voltage level that is provided by the power sources included in the power generation system 310 that will be apparent to those skilled in the relevant art(s) without departing from the spirit and scope of the disclosure. The power generation system 310 may then provide the electric power 350 at the voltage level 13.8kV to the power distribution trailer 320 via a medium voltage cable.

**[0064]** In continuing for purposes of discussion, the power distribution trailer 320 may then distribute the electric power 350 at the power generation voltage level to a plurality of single VFDs 340(a-n), where n is an integer equal to or greater than two, with each single VFD 340(a-n) positioned on a corresponding single trailer 330(a-n) from a plurality of single trailers, where n is an integer equal to or greater than two. The power distribution trailer 320 may include a switchgear configuration 305 that includes a plurality of switchgears 325(a-n), where n is an integer equal to or greater than two, to distribute the electric power 350 generated by the at least one power source included in the power distribution trailer 310 at the power generation voltage level 360 to each corresponding single VFD 340(a-n) positioned on each corresponding trailer 330(a-n).

**[0065]** Since the electric power 350 is consolidated to the power generation system 310, the switch gear configuration 305 of the power distribution trailer 320 may distribute the electric power 350 at the power generation voltage level as generated by the power generation system 310 to each of the single VFDs 340(a-n) as electric power 360 at the power generation voltage level such that the each of the single VFDs 340(a-n) may then drive the single shaft electric motors and the single hydraulic pumps as discussed in detail below. For example, the switch gear configuration 305 of the power distribution trailer 320 may distribute the electric power 350 at the power generation voltage level of 13.8kV to each of the single VFDs 340(a-n) as electric power 360 at the power generation voltage level of 13.8kV when the power distribution system 310 has power sources that include gas turbine engines. In another example, the switch gear configuration 305 of the power distribution trailer 320 may distribute the electric power 350 at the power generation level of 12.47kV to each of the single VFDs 340(a-n) as electric power 360 at the power generation level of 12.47kV when the power distribution 310 has power sources that include an electric power plant.

**[0066]** In order for the electric power to be consolidated to the power generation system 310 as well as to provide an electric driven system in which each of the components of the electric driven hydraulic fracking system 300 is driven by the electric power generated by the power generation system 310, the power distribution trailer 320 provides the flexibility to distribute the electric power 350 generated by the power generation system 310 at different voltage levels. In adjusting the voltage levels that the electric power 350 generated by the power generation system 310 is distributed, the power distribution trailer 320 may then distribute the appropriate voltage levels to several different components included in the electric driven hydraulic fracking system 300 to accommodate the electric power requirements of the several different components included in the electric driven hydraulic fracking system 300. For example, the power distribution trailer 320 may distribute the electric power 360 generated by the power generation system 310 at the voltage level of 13.8kV as generated by the power generation system 310 via the switch gears 325(a-n) to each of the single VFDs 340(a-n) for the each of the single VFDs 340(a-n) to drive the single shaft electric motors and the single hydraulic pumps. In another example, the power distribution trailer 320 may distribute the electric power 360 generated by the power generation system 310 at the voltage level of 12.47kV as generated by the power generation system 310 via the switch gears 325(a-n) to

each of the single VFDs 340(a-n) for each of the single VFDs 340(a-n) to drive the single shaft electric motors and the single hydraulic pumps.

**[0067]** However, the electric power distribution trailer 320 may also distribute the electric power 350 generated by the power generation system 310 at a decreased voltage level from the voltage level of the electric power 350 originally generated by the power generation system 310. Several different components of the electric driven hydraulic fracking system 300 may have power requirements that require electric power at a significantly lower voltage level than the electric power 350 originally generated by the power generation system 310. In doing so, the power distribution trailer 320 may include a switchgear transformer configuration 335 that may step-down the voltage level of the electric power 350 as originally generated by the power distribution trailer 310 to a lower voltage level that satisfies the power requirements of those components that may not be able to handle the increased voltage level of the electric power 350 originally generated by the power distribution trailer 310. In doing so, the electric power distribution trailer 320 may provide the necessary flexibility to continue to consolidate the electric power 350 to the power generation system 310 while still enabling each of the several components to be powered by the electric power generated by the power generation system 310.

**[0068]** For example, the switchgear transformer configuration 335 may convert the electric power 350 generated by the at least one power source of the power generation system 310 at the power generation voltage level to at an auxiliary voltage level that is less than the power generation voltage level. The switchgear transformer configuration 335 may then distribute the electric power 355 at the auxiliary voltage level to each single VFD 340(a-n) on each corresponding single trailer 330(a-n) to enable each single VFD 340(a-n) from the plurality of single VFDs 340(a-n) to communicate with the fracking control center 380. The switchgear transformer configuration 335 may also distribute the electric power 355 at the auxiliary voltage level to a plurality of auxiliary systems 390. The plurality of auxiliary systems 390 assists each single hydraulic pump as each hydraulic pump from the plurality of single hydraulic pumps operate to prepare the well for the later extraction of the fluid from the well.

**[0069]** In such an example, the switchgear transformer configuration 335 may convert the electric power 350 generated by the power generation system 310 with power sources include gas turbine engines at the power generation voltage level of 13.8kV to an auxiliary voltage

level of 480V that is less than the power generation voltage level of 13.8kV. The switchgear transformer configuration 335 may then distribute the electric power 355 at the auxiliary voltage level of 480V to each single VFD 340(a-n) on each corresponding single trailer 330(a-n) to enable each single VFD 340(a-n) from the plurality of single VFDs 340(a-n) to communicate with the fracking control center 380. The switchgear transformer configuration 335 may also distribute the electric power 355 at the auxiliary voltage level of 480V to a plurality of auxiliary systems 390. In another example, the switchgear transformer configuration 335 may convert the electric power 350 generated by the power generation system 310 with power sources that include an electric power plant at the power generation voltage level of 12.47kV to an auxiliary voltage level of 480V that is less than the power generation voltage level of 12.47kV. In another example, the switchgear transformer configuration 33 may convert the electric power 350 at the power generation voltage level generated by the power generation system 310 to the auxiliary voltage level of 480V, 120V, 24V and/or any other auxiliary voltage level that is less than the power generation voltage level. The switchgear transformer configuration 335 may convert the electric power 350 at the power generation voltage level generated by the power generation system 310 to any auxiliary voltage level that is less than the power generation voltage level to assist each single VFD 340(a-n) in executing operations that do not require the electric power 360 at the power generation voltage level that will be apparent to those skilled in the relevant art(s) without departing from the spirit and scope of the disclosure.

**[0070]** Unlike each of the single VFDs 340(a-n) that may convert the electric power 360 at the power generation voltage level to drive the single shaft electric motors and the single hydraulic pumps, the fracking control center 380, the auxiliary systems 390, the trailer auxiliary systems 315(a-n) as well as the operation of features of the single VFDS 340(a-n) that are unrelated to the driving of the single shaft electric motors and the single hydraulic pumps require the electric power to be stepped down to the electric power 355 at the auxiliary voltage level. The switchgear transformer configuration 335 may provide the necessary flexibility to step-down the electric power 360 at the power generation voltage level to the generate the electric power 355 at the auxiliary voltage level such that the remaining components of the electric driven hydraulic fracking system 300 may also be electrically driven by the electric power consolidated to the power generation system 310.

**[0071]** In stepping down the electric power 350 generated by the power generation system 310 at the power generation voltage level, the switchgear transformer configuration 335 may provide the electric power 355 at the auxiliary voltage level to the auxiliary systems 390. In doing so, the auxiliary systems 390 may be electrically driven by the electric power 355 at the auxiliary voltage level such that the electric power consolidated by the power generation system 310 may drive the auxiliary systems 390. The auxiliary systems 390 may include but are not limited to hydration systems, chemical additive systems, fracturing systems, blending systems, mixing systems and so on such that each of the auxiliary systems 390 required to execute the fracking operation may be electrically driven by the electric power consolidated by the power generation system 310. Further, the power distribution trailer 320 may also route a communication link 365 to each of the auxiliary systems 390 such that the fracking control center 380 may intervene and control each of the auxiliary systems 390 via the communication link 365 if necessary.

**[0072]** The switchgear transformer configuration 335 may also provide the electric power 355 at the auxiliary voltage level to the fracking control center 380. In providing the auxiliary voltage level to the fracking control center 380, the fracking control center 380 may remotely control the auxiliary systems 390, the single VFDs 340(a-n), as well as the trailer auxiliary systems 315(a-n) as requested by the fracking control center 380. The power distribution trailer 320 may route the communication link 365 to the auxiliary systems 390, the single VFDs 340(a-n), and the trailer auxiliary systems 315(a-n) such that the fracking control center 380 may communicate with each of the auxiliary systems 390, the single VFDs 340(a-n), and the trailer auxiliary systems 315(a-n) and thereby control via the communication link 365. As discussed above, the communication link 365 may be a wireline and/or wireless communication link.

**[0073]** The switchgear transformer configuration 335 may also provide the electric power 355 at the auxiliary voltage level to each of the single VFDs 340(a-n). As discussed above and below, the single VFDs 340(a-n) convert the electric power 360 generated by the power generation system 310 at the power generation voltage level to drive the single shaft electric motors and the single hydraulic pumps. However, the single VFD 340(a-n) may also operate with different functionality without having to drive the single shaft electric motors and the single hydraulic pumps. For example, the auxiliary systems 315(a-n) positioned on the pump

trailers 330(a-n) and/or included in the single VFDs 340(a-n) may operate as controlled by a corresponding VFD controller 345(a-n) that is positioned on the corresponding single trailer 330(a-n) and associated with the corresponding single VFD 340(a-n).

**[0074]** In doing so, the single VFD controllers 345(a-n) may operate the auxiliary systems 315(a-n) when the single VFD 340(a-n) is simply provided the electric power 355 at the auxiliary voltage level rather than having to operate with the electric power 360 at the power generation voltage level. In doing so, the fracking control center 380 may also communicate with the VFD controllers 345(a-n) and the single VFDs 340(a-n) as well as the trailer auxiliary systems 315(a-n) via the communication link 365 when the stepped-down electric power 355 at the auxiliary voltage level is provided to each of the single VFDs 340(a-n). In addition to operating auxiliary systems 315(a-n) when the corresponding single VFD 340(a-n) is provided the electric power 355 at the auxiliary voltage level, the VFD controller 345(a-n) may also operate the trailer auxiliary systems 315(a-n) as well as control the corresponding single shaft electric motor 150(a-n) that then drives each of the corresponding hydraulic pumps 160(a-n) to continuously pump the fracking media into the well to execute the fracking operation to extract the fluid from the well when the electric power 360 at the power generation voltage level is provided to the single VFDs 340(a-n).

**[0075]** For example, the single VFDs 340(a-n) may operate at a reduced capacity when the switchgear transformer configuration 335 provides the electric power 355 at the auxiliary voltage level. In doing so, the single VFDs 340(a-n) may operate in a maintenance mode in which the electric power 355 at the auxiliary voltage level is sufficient for the single VFDs 340(a-n) to spin the single shaft electric motors but not sufficient to drive the single shaft electric motors at the RPM levels that the single shaft electric motors are rated. In operating the single VFDs 340(a-n) in the maintenance mode with the electric power 355 at the auxiliary voltage level, the hydraulic pumps as well as the fracking equipment 370 may be examined and maintenance may be performed on the hydraulic pumps and the fracking equipment 370 to ensure the hydraulic pumps 160(a-n) and the fracking equipment 370 are operating adequately. The VFD controllers 345(a-n) of the single VFDs 340(a-n) may execute the functionality of the single VFDs 340(a-n) when operating in the maintenance mode. The fracking control center 380 may also remotely control the single VFDs 340(a-n) via the

communication link 365 to execute the functionality of the single VFDs 340(a-n) when operating in the maintenance mode.

**[0076]** In another example, the trailer auxiliary systems 315(a-n) may be operated when the single VFDs 340(a-n) are operating at the reduced capacity when the switchgear transformer configuration 335 provides the electric power 355 at the auxiliary voltage level. The trailer auxiliary systems 315(a-n) may be auxiliary systems positioned on the pump trailers 330(a-n) and/or included in the single VFDs 340(a-n) such that auxiliary operations may be performed on the single VFDs 340(a-n), the single shaft electric motors, and/or the single hydraulic pumps to assist in the maintenance and/or operation of the single VFDs 340(a-n) the single shaft electric motors and/or single hydraulic pumps when the electric power 355 at the auxiliary voltage level is provided to the single VFDs 340(a-n). For example, the trailer auxiliary systems 315(a-n) may include but are not limited to motor blower systems, the lube oil controls, oil heaters, VFD fans, and/or any other type of auxiliary system that is positioned on the pump trailers 330(a-n) and/or included in the single VFDs 340(a-n) to assist in the maintenance and/or operation of the single VFDs 340(a-n), single shaft electric motors, and/or single hydraulic pumps that will be apparent to those skilled in the relevant art(s) without departing from the spirit and scope of the disclosure.

**[0077]** As discussed above, FIG. 3 summarizes the functionality of the of distribution of the electric power 350 as generated by the power generation system 310 and then distributed by the power distribution trailer 320 with regard to how the electric power 350 is provided to each of the single VFDs 340(a-n) positioned on each of the corresponding pump trailers 330(a-n). FIG. 4 illustrates a block diagram of an electric driven hydraulic fracking system 400 that further describes the incorporation of the power distribution trailer 320 into the electric driven hydraulic fracking system 400. The power distribution trailer 320 includes a power distribution trailer controller 430, an auxiliary system transformer 410, an additional system transformer 420 that provides electric power 350 to an additional system 440, and the incorporation of a black start generator 405.

**[0078]** The switchgear transformer configuration 335 as discussed generally in FIG. 3 is discussed in more detail below with regard to FIG. 4 in that the electric power 350 distributed by the power distribution trailer 320 may be further customized to provide electric power 350 at several different voltage levels to different systems included in the electric driven hydraulic

fracking system 400. The electric driven hydraulic fracking system 400 shares many similar features with the hydraulic fracking operation 100, the single pump configuration 200, and the electric driven hydraulic fracking system 300; therefore, only the differences between the electric driven hydraulic fracking system 400 and the hydraulic fracking operation 110, the single pump configuration 200, and the electric driven hydraulic fracking system 300 are to be discussed in further detail.

**[0079]** As noted above, the trailer auxiliary systems 315(a-n) as well as the operation of features of the single VFDS 340(a-n) that are unrelated to the driving of the single shaft electric motors and the single hydraulic pumps require the electric power 350 to be stepped down to the electric power 355 at the auxiliary voltage level. The switchgear transformer configuration 335 may provide the necessary flexibility to step-down the electric power 360 at the power generation voltage level to generate the electric power 355 at the auxiliary voltage level such that the remaining components of the electric driven hydraulic fracking system 300 may also be electrically driven by the electric power 350 consolidated to the power generation system 310. Specifically, the switchgear transformer configuration 335 includes the auxiliary transformer 410 and the additional system transformer 420 as well as any other transformer necessary to customize the electric power 350 distributed by the power distribution trailer 320 to differentiate the power generation voltage level 360 of the electric power 350 to the appropriate voltage levels, such as the voltage level of 480V, required to power other systems that do not have the capability to step-down the power generation voltage level 360 to lower voltages and/or simply require significantly lower voltages to operate.

**[0080]** For example, the auxiliary system transformer 410 may step-down the electric power 350 generated at the voltage level of 13.8kV and distribute the electric power 355 at the auxiliary voltage level of 480V to each single VFD 340(a-n) on each corresponding single trailer 330(a-n) to enable each single VFD 340(a-n) from the plurality of single VFDs 340(a-n) to communicate with the fracking control center 380. The auxiliary system transformer 410 may also step-down the electric power 350 to the electric power 355 at the auxiliary voltage level of 480V to each single VFD 340(a-n) such that each single VFD 340(a-n) may operate at a reduced capacity to enable each VFD controller 345(a-n) operate the trailer auxiliary systems 315(a-n) without having to actually operate in a full capacity via the electric power 350 generated at the voltage level of 13.8kV. In doing so, the auxiliary system transformer 410

may enable the VFD controller 345(a-n) to operate the trailer auxiliary systems 315(a-n) such as the motor blower systems, the lube oil controls, oil heaters, VFD fans, and/or any other type of auxiliary system that is positioned on the pump trailers 330(a-n) and/or included in the single VFDs 340(a-n) without having to have the electric power 360 at the voltage level of 13.8kV provided to the single VFDs 340(a-n).

**[0081]** The auxiliary system transformer 410 may also step-down the electric power 350 generated at the power generation voltage level and distribute the electric power 355 at the auxiliary voltage level to each single VFD 340(a-n) on each corresponding single trailer 330(a-n) to enable a transformer included with each single VFD 340(a-n) to be pre-magnetized before opening each single VFD 340(a-n) to the electric power 360 at the power generation voltage level. Each single VFD 340(a-n) when activated by the electric power 360 at the power generation voltage level may generate a significant in-rush of current due to the significant amount of current that each single VFD 340(a-n) may generate once activated by the electric power 360 at the power generation voltage level. The significant in-rush of current generated by each single VFD 340(a-n) once activated by the electric power 360 at the power generation voltage level may then propagate back to the power generation system 310 and have a negative impact on the power generation system 310.

**[0082]** For example, the power generation system 310 is an electric power plant that generates the electric power 360 at the power generation voltage level of 12.47kV and provides such electric power 350 to the power distribution trailer 320 to be distributed to each single VFD 340(a-n). The electric power plant 310 often times independently generates electric power for an electric utility grid. A significant in-rush of current generated from each single VFD 340(a-n) after each single VFD 340(a-n) is activated by the electric power 360 at the power generation voltage level of 12.47kV that is then propagated back to the electric power plant 310 may negatively impact the electric utility grid that the electric power plant 310 independently generates electric power for. Thus, the operators of the electric power plant 310 require that the in-rush of current that is propagated back to the electric power plant 310 generated by each single VFD 340(a-n) be significantly mitigated.

**[0083]** In order to significantly mitigate the in-rush of current that is propagated back to the power generation system 310 after each single VFD 340(a-n) is activated by the electric power 360 at the power generation voltage level, each single VFD 340(a-n) may include a

transformer (not shown). The auxiliary system transformer 410 may provide the electric power 355 at the auxiliary voltage level to each transformer included with each single VFD 340(a-n). Each transformer may isolate each corresponding single VFD 340(a-n) from the electric power 360 at the power generation voltage level while each transformer is pre-magnetized with the electric power 355 at the auxiliary voltage level as provided by the auxiliary system transformer 410. Each transformer may then activate each corresponding single VFD 340(a-n) with the electric power 355 at the auxiliary voltage level by pre-charging the capacitors associated with each single VFD 340(a-n) with the electric power 355 at the auxiliary voltage level.

**[0084]** In doing so, each single VFD 340(a-n) may essentially be exposed to the electric power 355 at the auxiliary voltage level and pre-charge to a voltage threshold of the electric power 355 at the power generation voltage level. For example, the each single VFD 340(a-n) may pre-charge with the electric power 355 at the auxiliary voltage level to the voltage threshold of 20% to 25% of the electric power 360 at the power generation voltage level. The voltage threshold may be any percentage of the electric power 360 at the power generation voltage level that each single VFD 340(a-n) is to pre-charge to prevent an in-rush of current that may negatively impact the power generation system 310 that will be apparent to those skilled in the relevant art(s) without departing from the spirit and scope of the disclosure.

**[0085]** After each single VFD 340(a-n) has pre-charged to the voltage threshold based on the electric power 355 at the auxiliary voltage level as provided by the auxiliary system transformer 410, each corresponding transformer may then transition to enable each single VFD 340(a-n) to then be exposed to the electric power 360 at the power generation voltage level. In doing so, each single VFD 340(a-n) may then be powered by the electric power 360 at the power generation voltage level and thereby decrease to the VFD voltage level of at least 4160V to drive the single shaft electric motor 150(a-n) and the single hydraulic pump 160(a-n). However, the in-rush of current that may propagate back to the power generation system 310 may be significantly reduced due to the pre-charge of each single VFD 340(a-n) due to each corresponding transformer providing the electric power 355 at the auxiliary voltage level to each single VFD 340(a-n) as provided by the auxiliary system transformer 410 before exposing each single VFD 340(a-n) to the electric power 360 at the power generation voltage level. Thus, any negative impact to the power generation system 310 after each single VFD

340(a-n) is exposed to the electric power 360 at the power generation voltage level is significantly decreased.

**[0086]** In an embodiment, the electric driven hydraulic fracking system 400 may include a black start generator 405. The black start generator 405 generates power and provides black start electric power 460 to the single VFDs 340(a-n) via the power distribution trailer 320 without having to rely on the power generation system 310 to provide power to the single VFDs 340(a-n). In doing so, the black start generator 405 may provide black start electric power 460 to the single VFDs 340(a-n) while the power generation system 310 is inactive such that the voltage level of the black start electric power 460 is sufficient to thereby enable the single VFDs 340(a-n) to operate, enable the transformers associated with the single VFDs 340(a-n) to pre-magnetize and pre-charge the single VFDs 340(a-n), enable the VFD controllers 345(a-n) to operate the trailer auxiliary systems 315(a-n), and/or enable any other functionality related to the single VFDs 340(a-n) without having to activate the power generation system 310 that will be apparent to those skilled in the relevant art(s) without departing from the spirit and scope of the disclosure. In an embodiment, the black start electric power 460 may be at a voltage level that is substantially equivalent to the voltage level of the electric power 355 provided by the auxiliary transformer 410. For example, the black start electric power 460 may be at a black start voltage level of 480V. The black start electric power 460 may be at any voltage level that is sufficient to activate the single VFDs 340(a-n) to operate in a decreased capacity as compared to when the single VFDs 340(a-n) are provided with the electric power 360 at the power generation voltage level that will be apparent to those skilled in the relevant art(s) without departing from the spirit and scope of the disclosure.

**[0087]** As discussed in detail above, the auxiliary system transformer 410 may provide the electric power 355 at the auxiliary voltage level to each single VFD 340(a-n) so that each single VFD 340(a-n), each transformer associated with each single VFD 340(a-n), each VFD controller 345(a-n), the trailer auxiliary systems 315(a-n), and so on may operate as discussed in detail above. However, such operation based on the electric power 355 at the auxiliary voltage level still requires that the power generation system 310 generate the electric power 350 at the power generation voltage level. In doing so, the power sources included in the power generation system 310 are required to be activated and operating at a capacity necessary to generate the electric power 350 at the power generation voltage level. Such an operation of

the power sources to generate the electric power 350 at the power generation voltage level consumes significant energy. However, such significant consumption of energy by the power sources of the power generation system 310 to generate the electric power 350 at the power generation voltage level may be unnecessary when each single VFD 340(a-n) may simply require to operate with the electric power 355 at the auxiliary voltage level.

**[0088]** For example, significant time may lapse before the fracking operation is to initiate in which the fracking equipment 370 is required to be activated and to begin fracking the fluid from the well thereby requiring the single shaft motors 150(a-n) to drive the single fluid pumps 160(a-n) in which the single VFDs 340(a-n) are required to provide the VFD voltage level of 4160V. During that lapse of significant time of preparation before the fracking operation, the single VFDs 340(a-n) may be activated via the electric power 355 at the auxiliary voltage level of 480V so that each single VFD 340(a-n), each transformer associated with each single VFD 340(a-n), each VFD controller 345(a-n), the trailer auxiliary systems 315(a-n), and so on may operate as discussed in detail above. However, to do so, having the power generation system 310 consume unnecessary energy to provide the electric power 355 at the auxiliary voltage level of 480V for such a significant amount of time before generating the electric power 360 at the power generation voltage level of 13.8kV and/or 12.47kV is unnecessary.

**[0089]** Rather, the black start generator 405 may provide the black start electric power 460 to the single VFDs 340(a-n) via the power distribution trailer 320 such that the single VFDs 340(a-n), the transformer associated with the single VFDs 340(a-n), the VFD controllers 345(a-n), the trailer auxiliary systems 315(a-n) and so on may operate at a reduced capacity while still contributing to the preparation of the fracking operation without requiring the activation of the power generation system 310. For example, the black start generator 405 may provide black start electric power 460 at the black start voltage level to each of the single VFDs 340(a-n) via the power distribution trailer 320 without having to activate the power generation system 310 to do so. In such an example, the back start electric power 460 at the black start voltage level provided to the single VFDs 340(a-n) via the power distribution trailer 320 may enable each of the VFD controllers 345(a-n) to be powered up as well as the ventilation systems of the trailer auxiliary systems 315(a-n) may be activated. The single VFDs 340(a-n) may pre-heat and feedback as to the status of the single VFDs 340(a-n) may be provided to the fracking

control center 380 via the VFD controllers 345(a-n) as to the status of the single VFDs 340(a-n) during pre-charge.

**[0090]** In doing so, the power generation system 310 may idle as the single VFDs 340(a-n) are preparing to arrive at a state to drive the single shaft electric motors 150(a-n) to initiate the fracking operation. Activating the power generation system 310 from an idle state as the single VFDs 340(a-n) prepare to arrive to a state to initiate the fracking operation is an unnecessary consumption of significant energy by the power generation system 310 when the black start generator 405 may provide the black start electric power 460 that is sufficient to prepare the single VFDs 340(a-n) to an operating state as well as during the preparation period to initiate the fracking operation while consuming significantly less power than the power generation system 310.

**[0091]** The VFD controllers 345(a-n) may provide feedback to the fracking control center 380 as to the status of the single VFDs 340(a-n) as the black start generator 405 provides the black start electric power 460 to the single VFDs 340(a-n) via the power distribution trailer 320. The fracking control center 380 may also monitor the power generation system 310 to determine when the power sources included in the power generation system 310 reach a status of being able to generate the electric power 350 at the power generation voltage level. Once the fracking control center 380 determines that the power generation system 310 has reached a status to generate the electric power 350 at the power generation voltage level, the fracking control center 380 may execute a synchronized transfer scheme to transfer the electric power provided by the power distribution trailer 320 to the single VFDs 340(a-n) from the black start electric power 460 provided by the black start generator 405 to the electric power 350 at the power generation voltage level provided by the power generation system 310. The fracking control center 380 may then deactivate the black start generator 405 such that the black start generator 405 no longer consumes unnecessary energy.

**[0092]** The power distribution trailer 320 may also provide additional flexibility with regard to additional electric power that may be generated from the electric power 350 at the power generation voltage level as generated by the power generation system 310 such that the additional electric power is provided at additional voltage levels in addition to the electric power 360 at the power generation voltage level and the electric power 355 at the auxiliary voltage level. As mentioned above, the hydraulic fracking system 400 may operate as an

isolated island in that all electric power required to operate all aspects of equipment required to execute the fracking operation may be provided from the power generation system 310 and then distributed by the power distribution trailer 320. In doing so, the power distribution trailer 320 may customize the voltage levels of the electric power 350 at the power generation voltage level generated by the power generation system 310 to distribute the necessary electric power at the necessary voltage levels to all aspects and/or equipment required for the execution of the fracking operation thereby not requiring additional power sources and/or power generation systems.

**[0093]** In doing so, the switchgear transformer configuration 335 may include an additional system transformer 420 that is in addition to the auxiliary system transformer 410. The additional system transformer 420 is a transformer included in the switchgear transformer configuration 335 that provides electric power 450 at an additional voltage level that differs from the electric power 355 at the auxiliary voltage level as provided by the auxiliary transformer 410. The additional system transformer 420 may provide electric power 450 at additional voltage levels that are higher than the auxiliary voltage level as well as additional voltage levels that are lower than the auxiliary voltage level. As a result, the additional system transformer 420 may provide the electric power 450 at the additional voltage level to an additional system 440 that requires electric power at a voltage level that differs from the electric power 355 at the auxiliary voltage level of 480V as provided by the auxiliary system transformer 410. Thus, the additional system transformer 420 may provide the electric power 450 at the additional voltage level that is customized for the additional system 440 such that the additional system 440 may also be powered by electric power generated by the power generation system 310 and distributed by the power distribution trailer 320.

**[0094]** For example, the additional system 440 may include a motor control center for a blending operation required for the fracking operation. In such an example, the motor control center for the blending operation may include four 500HP electric motors that require electric power 450 at the additional voltage level of 4160V in order to drive the blending equipment necessary to execute the blending operation during the fracking operation. The electric power 450 at the additional voltage level of 4160V differs from the electric power 360 at the power generation voltage level of 13.8kV and/or 12.47 kV as provided by the switchgear configuration 305 as well as differs from the electric power 355 at the auxiliary voltage level

of 480V as provided by the auxiliary system transformer 410. Rather, the additional system transformer 420 provides additional customization to the electric power 450 provided at the additional voltage level of 4160V such that the additional system 440 that requires the customized electric power 450 provided at the additional voltage level of 4160V in the motor control center for the blending operation may be distributed by the power distribution trailer 320.

**[0095]** In another example, the additional system 440 may include a site lighting system to provide light to the fracking site. In such an example, the lighting system requires electric power 450 at the additional voltage level of 120V in to provide to the lighting system to emit light to the fracking site. The electric power 450 at the additional voltage level of 120V differs from the electric power 360 at the power generation voltage level of 13.8kV and/or 12.47kV as provided by the switchgear configuration 305 as well as differs from the electric power 355 at the auxiliary voltage level of 480V as provided by the auxiliary system transformer 410. Rather, the additional system transformer 420 provides additional customization to the electric power 450 provided at the additional voltage level of 120V such that the additional system 440 that requires the customized electric power 450 provided at the additional voltage level of 120V in the lighting system may be distributed by the power distribution trailer 320. The additional transformer 420 may include any quantity of additional transformers in addition to the auxiliary system transformer 410 and may provide electric power 450 at any additional voltage level that is greater than and/or less than the electric power 355 at the auxiliary voltage level to provide such electric power as required by the any quantity of additional systems that will be apparent to those skilled in the relevant art(s) without departing from the spirit and scope of the disclosure.

**[0096]** The power distribution trailer 320 includes the power distribution trailer controller 430. The power distribution trailer controller 430 is the onboard control system for the power distribution trailer 320. The power distribution trailer controller 430 may operate each of the auxiliary features of the power distribution trailer 320 such as the air flow of the power distribution trailer 320 to ensure that the equipment positioned on the power distribution trailer 320 is cooled and maintained at a temperature that prevents damage to the equipment positioned on the power distribution trailer 320. In doing so, the power distribution trailer 320 may operate the auxiliary features of the power distribution trailer 320 in a similar manner as

the VFD controllers 345(a-n) operate the trailer auxiliary systems 315(a-n) of the pump trailers 330(a-n).

**[0097]** The power distribution controller 430 may also centralize the data that is generated by the components included in the electric driven hydraulic fracking system 400. As discussed in detail above, the power distribution trailer 320 distributes the electric power 350 at the power generation voltage level as generated by the power generation system 310 and then distributes the electric power 360 at the power generation voltage level and the electric power 355 at the auxiliary voltage level to the single VFDs 340(a-n) that is then provided to the VFD controllers 345(a-n) and the trailer auxiliary systems 315(a-n). The power distribution trailer 320 also distributes the electric power 355 at the auxiliary voltage level to the auxiliary systems 390. The power distribution trailer 320 also distributes the electric power 450 at the additional voltage level. In doing so, the power distribution trailer controller 430 communicates directly to each of the components included in the electric driven hydraulic fracking system 400 and thereby operates as a conduit of the communication of data generated by each of the components of the electric driven hydraulic fracking system 400 via communication link 365.

**[0098]** As a result, the power distribution controller 430 may act as a hub with regard to the data generated by the single VFDs 340(a-n), the VFD controllers 345(a-n), the trailer auxiliary systems 315(a-n), the additional systems 440, the auxiliary systems 390, the fracking control center 380, and/or the power generation system 310. As the single VFDs 340(a-n), the VFD controllers 345(a-n), the trailer auxiliary systems 315(a-n), the additional systems 440, the auxiliary systems 390, the fracking control center 380, and/or the power generation system 310 operate and/or collect data and/or generate data, such data may be distributed to the power distribution controller 430. The power distribution controller 430 may then distribute such data to the other components and/or execute operations based on the data received from each of the components included in the electrical driven hydraulic fracking system 400.

**[0099]** As the single VFDs 340(a-n) operate and the single shaft electric motors 150(a-n) drive the single hydraulic fluid pumps 160(a-n) to execute the fracking operation, the single VFDs 340(a-n) and the VFD controllers 345(a-n) may communicate data as to the status of the numerous parameters of the single VFDs 340(a-n), the single shaft electric motors 150(a-n) and the single hydraulic fluid pumps 160(a-n) as such components operate to execute the fracking operation to the power distribution controller 430. The power distribution controller

430 may then operate as a conduit of such data and provide such data to the fracking control center 380 such that the fracking control center 380 may determine any actions that may be required based on the current status of such components via communication link 365.

**[0100]** For example, the fracking control center 380 requires that 100 barrels per minute at 13000PSI be driven by the fracking equipment 370. The fracking control center 380 may then instruct the VFD controllers 345(a-n) to ramp up the single VFDs 340(a-n) such that the single shaft electric motors 150(a-n) may ramp up to drive the single hydraulic pumps 160(a-n) to drive the fracking equipment 370 at 100 barrels per minute at 13000PSI. The VFD controllers 345(a-n) may then provide data with regard to the current state of the single VFDs 340(a-n), the trailer auxiliary systems 315(a-n), the single shaft electric motors 150(a-n), the single hydraulic pumps 160(a-n) and so on with regard to the status of each component in real-time to the power distribution trailer controller 430. The power distribution trailer controller 430 may then operate as a conduit of such data to the fracking control center 380 such that the fracking control center 380 may monitor the status of each component in real-time based on the data provided by the power distribution trailer controller 430 to determine if any actions that may be required based on the current status of such components.

**[0101]** In another example, the power distribution trailer controller 430 may monitor the operation of the power sources included in the power generation system 310 to determine whether the electric power generated 350 at the power generation voltage level is sufficient for the single VFDs 340(-n) to drive the single shaft electric motors 150(a-n) to drive the single hydraulic pumps 160(a-n). In such an example, the power generation system 310 may include several gas turbine engines. The power distribution controller 430 may determine that the status of one of the gas turbine engines is signaling that the gas turbine engine is failing. In doing so, the fracking control center 380 may execute a load sharing to share the load of the failed gas turbine engine with the remaining active gas turbine engines to maintain the fracking operation. The power distribution trailer controller 430 may determine the load sharing of the gas turbine engines as provided by the fracking control center 380.

**[0102]** In doing so, the power distribution trailer controller 430 may determine the MW of electric power 350 being generated by the remaining gas turbine engines which is less than the MW of electric power 350 generated when each of the gas turbine engines were operational. The power distribution trailer controller 430 may then determine the amount of MW being

consumed by the single VFDs 340(a-n) to drive the single shaft electric motors 150(a-n) and the single hydraulic pumps 160(a-n) in executing the fracking operation. The power distribution controller 430 may then instruct the VFD controllers 345(a-n) to fade back the single VFDs 340(a-n) such that the single VFDs 340(a-n) consume the MW of electric power 360 as available from the remaining gas turbine engines to avoid a brown out and/or black out of the power generation system. In doing so, the fracking operation may continue uninterrupted despite a gas turbine engine failing.

**[0103]** Thus, the power distribution trailer controller 430 may act as the conduit as well as monitor each of the single VFDs 340(a-n), the VFD controllers 345(a-n), the trailer auxiliary systems 315(a-n), the additional systems 440, the auxiliary systems 390, the fracking control center 380, and/or the power generation system 310. As the single VFDs 340(a-n), the VFD controllers 345(a-n), the trailer auxiliary systems 315(a-n), the additional systems 440, the auxiliary systems 390, the fracking control center 380, and/or the power generation system 310 operate and/or collect data and/or generate data, such data may be distributed to the power distribution controller 430 via communication link 365.

**[0104]** FIG. 5 illustrates a block diagram of an of an electric driven hydraulic fracking system 500 that further describes the incorporation of the power distribution trailer into the electric driven hydraulic fracking system 500. The power distribution trailer includes a bus A 510, a bus B 520, a plurality of feeders 530(a-n), where n is equal to the quantity of VFD connections 550(a-n). The approach in how the electric power 350 at the power generation voltage level is distributed by the switch gear configuration 305, the auxiliary system transformer 410, and/or the black start generator 405 to the single VFDs 340(a-n) is discussed in more detail below. The electric driven hydraulic fracking system 500 shares many similar features with the hydraulic fracking operation 100, the single pump configuration 200, the electric driven hydraulic fracking system 300, and the electric driven hydraulic fracking system 400; therefore, only the differences between the electric driven hydraulic fracking system 500 and the hydraulic fracking operation 100, the single pump configuration 200, the electric driven hydraulic fracking system 300, and the electric driven hydraulic fracking system 400 are to be discussed in further detail.

**[0105]** The power generation trailer 320 includes bus A 510 and bus B 520. Bus A 510 may operate as an electric bus such that bus A 510 may propagate the electric power 355 at the

auxiliary voltage level. In doing so, bus A 510 may be electrically connected to any component included in the power distribution trailer 320 that provides the electric power 355 at the auxiliary voltage level. For example, bus A 510 may be electrically connected to the auxiliary system transformer 410 and/or the black start generator 405 such that the auxiliary system transformer 410 and/or the black start generator 405 provides the electric power 355 at the auxiliary voltage level. Bus B 520 may operate as an electric bus such that bus B 520 may propagate the electric power 360 at the power generation voltage level. In doing so, bus B 520 may be electrically connected to any component included in the power distribution trailer 320 that provides the electric power 360 at the auxiliary voltage level. For example, bus B 520 may be electrically connected to the switchgear configuration 305 such that the switchgear configuration provides the electric power 360 at the power generation voltage level.

**[0106]** Bus A 510 enables the different components included in the power distribution trailer 320 that provide the electric power 355 at the auxiliary voltage level, such as the auxiliary system transformer 410 and/or the black start generator 405, to easily distribute the electric power 355 at the auxiliary voltage level to each of the feeders 530(a-n). For example, the auxiliary system transformer 410 and/or the black start generator 405 may simply provide the electric power 355 at the auxiliary voltage level to Bus A 510 and then bus A 510 propagates the electric power 355 at the auxiliary voltage level to each of the feeders 530(a-n). Rather than have the auxiliary system transformer 510 and/or the black start generator 405 electrically connect to each of the different feeders 530(a-n) individually requiring significantly more cabling, the auxiliary system transformer 510 and/or the black start generator 505 may simply electrically connect to bus A 510 and then bus A 510 may propagate the electric power 355 at the auxiliary voltage level to each of the feeders 530(a-n).

**[0107]** Bus B 520 enables the different components included in the power distribution trailer 320 that provide the electric power 360 at the power generation voltage level, such as the switchgear configuration 305, to easily distribute the electric power 360 at the power generation voltage level to each of the feeders 530(a-n). For example, the switchgear configuration 305 may simply provide the electric power 360 at the power generation voltage level to Bus B 520 and then bus B 520 propagates the electric power 360 at the power generation voltage level to each of the feeders 530(a-n). Rather than have the switchgear configuration 305 electrically connect to each of the different feeders 530(a-n) individually

requiring significantly more cabling, the switchgear configuration 305 may simply electrically connect to bus B 520 and then bus B 520 may propagate the electric power 360 at the power generation voltage level to each of the feeders 530(a-n).

**[0108]** Each of the feeders 530(a-n) may provide the connections and include the appropriate relays and/or contacts to propagate the electric power 360 at the power generation voltage level as propagated from bus B 520, the electric power 355, 460 at the auxiliary voltage level as propagated from bus A 510, and the communication link 365 to the each of the single VFDs 340(a-n). The condensing of the electric power 360 at the power generation voltage level, the electric power 355, 460 at the auxiliary voltage level, and the communication link 365 into a corresponding single feeder 530(a-n) for each corresponding single VFD 340(a-n) enables the electric power 360, the electric power 355, 460, and the communication link 365 to be consolidated into a corresponding single cable 540(a-n). Rather than have numerous cables running from the power distribution trailer 320 to each of the different single VFDs 340(a-n) such that each of the electric power 360, the electric power 355, 460, and the communication link 365 is included in its own individual cable, each of the feeders 530(a-n) may consolidate the electric power 360, the electric power 355, 460, and the communication link 365 into a single corresponding cable 540(a-n) thereby significantly reducing the amount of cables required to be ran between the power distribution trailer 320 and each corresponding single VFD 340(a-n). Each of the cables 540(a-n) may then electrically connect the electric power 360, the electric power 355, 460, and the communication link 365 to each corresponding single VFD 340(a-n) via the VFD connection 550(a-n) associated with each single VFD 340(a-n).

**[0109]** The communication link 365 as included in the cables 540(a-n) may provide communication from the VFD connection 550(a-n) to the corresponding feeder 530(a-n) and then to the power distribution trailer controller 430. The communication link 365 may enable the power distribution trailer controller 430 to determine whether the appropriate electric power 360 at the voltage level of 13.8kV and the appropriate electric power 355 at the auxiliary level of 480V is connected from the appropriate feeder 530(a-n) to the appropriate VFD connection 550(a-n). Often times, installers of the electrical electric driven hydraulic fracking system 500 may incorrectly connect cables 540(a-n) such that the incorrect VFD connection 550(a-n) is connected to the incorrect feeder 530(a-n). In doing so, the incorrect electric power

360 at the power generation voltage level and/or the incorrect electric power 355 at the auxiliary voltage level may be connected to the incorrect single VFD 340(a-n).

**[0110]** For example, the installer in the confusion of installing the electric driven hydraulic fracking system 500 may incorrect connect cable 540a from feeder 530a to VFD connection 550n. In doing so, the installer connected the incorrect electric power 360 at the power generation voltage level of 13.8kV and/or the incorrect electric power 355 at the auxiliary voltage level of 480V to the incorrect single VFD 340n via VFD connection 550n. Rather than relying on manual policy and procedure for the installers to verify whether each cable 540(a-n) correctly connects each VFD connection 550(a-n) to each corresponding feeder 530(a-n), the power distribution trailer controller 430 may poll each feeder 530(a-n) and to thereby determine whether each feeder 530(a-n) is connected to the appropriate VFD connection 550(a-n) via the appropriate cable 540(a-n) via the communication link 365 included in each cable 540(a-n). In doing so, the power distribution trailer controller 430 may verify whether each feeder 530(a-n) is connected to the appropriate VFD connection 550(a-n) based on the polling via the communication link 365 included in each cable 540(a-n). The power distribution trailer controller 430 may then confirm that each feeder 530(a-n) is connected to each appropriate VFD connection 550(a-n) when each communication link 365 confirms based on the polling of the power distribution trailer controller 430. The power distribution trailer controller may then generate an alert and identify each feeder 530(a-n) that is connected to the incorrect VFD connection 550(a-n) when the communication link 365 identifies the incorrect connection based on the polling of the power distribution trailer controller 430.

**[0111]** As noted above, medium voltage cables may propagate the AC voltage signal 360 at the voltage level of 13.8kV from the power distribution trailer 320 to each of the VFDs 340(a-n). Low voltage cables may propagate the auxiliary voltage signal 355 at the auxiliary voltage level of 480V from the power distribution trailer 320 to each of the VFDs 340(a-n). Communication cables may propagate communication signals 365 from the power distribution trailer 320 to each of the VFDs 340(a-n). FIG. 6 illustrates a top-elevational view of connector configuration for each of the VFDs 340(a-n) that may couple to a medium voltage cable, a low voltage cable, and a communication cable.

**[0112]** The connector configuration 600 includes medium voltage connectors 610(a-b) with each including a medium voltage plug and receptacle to eliminate the need of skilled

personnel to connect the medium voltage cables to the VFDs 340(a-n) using hand tools and being thereby exposed to the conductors. Rather than using manual terminations with delicate termination kits, the medium voltage connections 610(a-b) with plugs enable medium voltage cables to be easily connected to the VFDs 340(a-n) to propagate the AC voltage signal 360 at the power generation voltage level without any risk of shorts and/or nicks in the cable. The medium voltage connections 610(a-b) include lockable provisions that prevent unauthorized connection or disconnection of the medium voltage cables to the medium voltage connections 610(a-b) and provide lock out tag out features for safe working on system components. The low voltage connections 620(a-b) provide connections to the low voltage cables that propagate the auxiliary voltage signal 355 at the auxiliary voltage level of 480V to the VFDs 340(a-n). The communication connection 630 provides a connection to the communication cable to propagate communication signals 365 to the VFDs 340(a-n).

#### CONCLUSION

**[0113]** It is to be appreciated that the Detailed Description section, and not the Abstract section, is intended to be used to interpret the claims. The Abstract section may set forth one or more, but not all exemplary embodiments, of the present disclosure, and thus, is not intended to limit the present disclosure and the appended claims in any way.

**[0114]** The present disclosure has been described above with the aid of functional building blocks illustrating the implementation of specified functions and relationships thereof. The boundaries of these functional building blocks have been arbitrarily defined herein for the convenience of the description. Alternate boundaries may be defined so long as the specified functions and relationships thereof are appropriately performed.

**[0115]** It will be apparent to those skilled in the relevant art(s) the various changes in form and detail can be made without departing from the spirit and scope of the present disclosure. Thus the present disclosure should not be limited by any of the above-described exemplary embodiments, but should be defined only in accordance with the following claims and their equivalents.

**WHAT IS CLAIMED IS:**

1. An electric driven hydraulic fracking system that positions a single variable frequency drive (VFD), a single shaft electric motor, and a single hydraulic pump mounted on a single pump trailer to pump a fracking media into a fracking well to execute a fracking operation to extract a fluid from the fracking well, comprising:

a power generation system that is configured to generate electric power at a power generation voltage level, wherein the electric power generated at the power generation voltage level is a voltage level that the power generation system is capable to generate;

a power distribution trailer that is configured to:

distribute the electric power generated by the power generation system at the power generation voltage level to the single VFD positioned on the single pump trailer, wherein the single VFD converts the electric power at the power generation level to a VFD voltage level to control an operation of the single shaft motor and single hydraulic pump positioned on the single pump trailer,

convert the electric power generated by the power generation system at the power generation voltage level to an auxiliary voltage level that is less than the power generation voltage level, and

distribute the electric power at the auxiliary voltage level to the single VFD positioned on the single pump trailer, wherein the electric power at the auxiliary voltage level controls an operation of a plurality of auxiliary systems associated with the single pump trailer.

2. The electric driven hydraulic fracking system of claim 1, wherein the power distribution trailer comprises:

a switchgear configuration that is configured to distribute the electric power generated by the power distribution trailer at the power generation voltage level to the single VFD positioned on the single pump trailer.

3. The electric driven hydraulic fracking system of claim 2, wherein the power distribution trailer further comprises:

**a switchgear transformer configuration that is configured to:**

**convert the electric power generated by the power generation system at the power generation voltage level to the auxiliary voltage level,**

**distribute the electric power at the auxiliary voltage level to the single VFD positioned on the single pump trailer to enable the single VFD to communicate with a fracking control center, and**

**distribute the electric power at the auxiliary voltage level to the plurality of auxiliary systems associated with the single pump trailer, wherein the plurality of auxiliary systems assists the single hydraulic pump as the single hydraulic pump operates to execute the fracking operation to extract the fluid from the well.**

**4. The electric driven hydraulic fracking system of claim 3, wherein the switchgear transformer configuration comprises:**

**an auxiliary system transformer that is configured to:**

**convert the electric power generated at the power generation voltage level to the auxiliary voltage level,**

**distribute the electric power at the auxiliary voltage level to the plurality of auxiliary systems associated with the single pump trailer, wherein the plurality of auxiliary systems assists the single hydraulic pump as the single hydraulic pump operates to execute the fracking operation to extract the fluid from the well; and**

**an additional system transformer that is configured to:**

**convert the electric power generated at the power generation voltage level to an additional voltage level that is less than the power generation voltage level and differs from the auxiliary voltage level, and**

**distribute the electric power at the additional voltage level to an additional system associated with the electric driven hydraulic fracking system, wherein the electric power at the additional voltage level controls an operation of the additional system associated with the electric driven hydraulic fracking system.**

**5. The electric driven hydraulic fracking system of claim 2, further comprises: a black start generator that is configured to:**

generate the electric power at a black start voltage level, wherein the electric power generated at the black start voltage level is a voltage level that is less than the power generation voltage level; and

provide the electric power at the black start voltage level to the power distribution trailer to distribute the electric power at the black start voltage level to the single VFD positioned on the single pump trailer, wherein the electric power at the black start voltage level powers the single VFD when the power generation system is not generating the electric power at the power generation voltage level.

6. The electric driven hydraulic fracking system of claim 2, wherein the power distribution trailer comprises:

a power distribution trailer controller that is configured to operate as a gateway of data generated by the single VFD and the power generation system to enable a fracking control center associated with electric driven hydraulic fracking system to monitor the operation of the single VFD, the single shaft electric motor, the single hydraulic pump, and the trailer auxiliary systems.

7. The electric driven hydraulic fracking system of claim 6, wherein the power distribution trailer controller is further configured to:

monitor data provided by the single VFD as the single hydraulic pump operates on a continuous duty cycle to continuously pump the fracking media into the well at a HP level of at least 4000HP; and

automatically adjust the operation of the single VFD when the data provided by the single VFD indicates a fluctuation as the single hydraulic pump operates on the continuous duty cycle to continuously pump the fracking media into the well at the HP level of at least 4000HP.

8. A method for an electric driven hydraulic fracking system that positions a single variable frequency drive (VFD), a single shaft electric motor, and a single hydraulic pump mounted on a single pump trailer to pump a fracking media into a well to execute a fracking

operation to extract a fluid from the well, comprising:

generating electric power by a power generation system at a power generation voltage level, wherein the electric power generated at the power generation voltage level is the power generation voltage level that the power generation system is capable to generate;

distributing by a power distribution trailer the electric power at the power generation voltage level to the single VFD positioned on the single pump trailer, wherein the single VFD converts the electric power at the power generation level to a VFD voltage level to control an operation of the single shaft motor and the single hydraulic pump positioned on the single pump trailer;

converting the electric power generated by the power generation system at the power generation voltage level to an auxiliary voltage level that is less than the power generation voltage level; and

distributing the electric power at the auxiliary voltage level to the single VFD positioned on the single pump trailer, wherein the electric power at the auxiliary voltage level controls an operation of a plurality of auxiliary systems associated with the single pump trailer.

9. The method of claim 8, the distributing comprises:

distributing by a switchgear configuration the electric power generated by the power distribution system at the power generation voltage level to the single VFD positioned on the single pump trailer.

10. The method of claim 9, further comprising:

converting by a switchgear transformer configuration the electric power generated by the power generation system at the power generation voltage level to the auxiliary voltage level;

distributing the electric power at the auxiliary voltage level to the single VFD positioned on the single pump trailer to enable the single VFD to communicate with a fracking control center; and

distributing the electric power at the auxiliary voltage level to the plurality of

auxiliary systems associated with the single pump trailer, wherein the plurality of auxiliary systems assists the single hydraulic pump as the single hydraulic pump operates to execute the fracking operation to extract the fluid from the well.

11. The method of claim 10, further comprising:

converting by an additional system transformer the electric power generated at the power generation voltage level to an additional voltage level that is less than the power generation voltage level and differs from the auxiliary voltage level; and

distributing the electric power at the additional voltage level to an additional system associated with the electric driven hydraulic fracking system, wherein the electric power at the additional voltage level controls an operation of the additional system associated with the electric driven hydraulic fracking system.

12. The method of claim 9, further comprising:

generating the electric power at a black start voltage level, wherein the electric power generated at the black start voltage level is a voltage level that is less than the power generation voltage level; and

providing the electric power at the black start voltage level to the power distribution trailer to distribute the electric power at the black start voltage level to the single VFD positioned on the single pump trailer, wherein the electric power at the black start voltage level powers the single VFD when the power generation system is not generating the electric power at the power generation voltage level.

13. The method of claim 9, further comprising:

operating as a gateway by a power distribution trailer controller of data generated by the single VFD and the power generation system to enable a fracking control center associated with the electric driven hydraulic fracking system to monitor the operation of the single VFD, the single shaft electric motor, the single hydraulic pump, and the trailer auxiliary systems.

14. The method of claim 13, further comprising:

monitoring data provided by the single VFD as the single hydraulic pump operates

on a continuous duty cycle to continuously pump the fracking media into the well at a HP level of at least 4000HP; and

automatically adjusting the operation of the single VFD when the data provided by the single VFD indicates a fluctuation as the single hydraulic pump operates on the continuous duty cycle to continuously pump the fracking media into the well at the HP level of at least 4000HP.

15. An electric driven hydraulic fracking system that positions a single variable frequency drive (VFD), a single shaft electric motor, and a single hydraulic pump mounted on a single pump trailer to pump a fracking media into a fracking well to execute a fracking operation to extract a fluid from the fracking well, comprises:

a power generation system that is configured to generate electric power at a power generation voltage level, wherein the electric power generated at the power generation voltage level is a power generation voltage level that the power generation system is capable to generate;

a power distribution trailer that is configured to:

distribute the electric power generated by the power generation system at the power generation voltage level to a plurality of single VFDs positioned on a plurality of single pump trailers, wherein each single VFD converts the electric power at the power generation level to a VFD voltage level to control an operation of a corresponding single shaft motor from a plurality of single shaft motors and a corresponding single hydraulic pump from a plurality of single hydraulic pumps positioned on the corresponding single pump trailers,

convert the electric power generated by the power generation system at the power generation voltage level to an auxiliary voltage level that is less than the power generation voltage level, and

distribute the electric power at the auxiliary voltage level to each single VFD positioned on each corresponding single pump trailer, wherein the electric power at the auxiliary voltage level controls an operation of a plurality of auxiliary systems associated with each corresponding single pump trailer.

16. The electric driven hydraulic fracking system of claim 15, wherein the power distribution trailer comprises:

a switchgear configuration that is configured to distribute the electric power generated by the power distribution trailer at the power generation voltage level to the plurality of single VFDs positioned on the single pump trailer.

17. The electric driven hydraulic fracking system of claim 16, wherein the power distribution trailer further comprises:

a switchgear transformer configuration that is configured to:

convert the electric power generated by the power generation system at the power generation voltage level to the auxiliary voltage level,

distribute the electric power at the auxiliary voltage level to the plurality of single VFDs positioned on the corresponding plurality of single pump trailers to enable the plurality of single VFDs to communicate with a fracking control center; and

distribute the electric power at the auxiliary voltage level to the plurality of auxiliary systems associated with each of the single pump trailers from the plurality of single pump trailers, wherein the plurality of auxiliary systems assists each corresponding single hydraulic pump from the plurality of hydraulic pumps as each corresponding single hydraulic pump operates to execute the fracking operation to extract fluid from the well.

18. The electric driven hydraulic fracking system of claim 17, wherein the switchgear transformer configuration system comprises:

an auxiliary system transformer that is configured to:

convert the electric power generated at the power generation voltage level to the auxiliary voltage level,

distribute the electric power at the auxiliary voltage level to the plurality of auxiliary systems associated with each of the single pump trailers, wherein the plurality of auxiliary systems assists each of the single corresponding single pump trailers as each of the corresponding single hydraulic pumps operate to execute the fracking operation to extract the fluid from the well; and

**an additional system transformer that is configured to:**

**convert the electric power generated at the power generation voltage level to an additional voltage level that is less than the power generation voltage level and differs from the auxiliary voltage level, and**

**distribute the electric power at the additional voltage level to an additional system associated with the electric driven hydraulic fracking system, wherein the electric power at the additional voltage level controls an operation of the additional system associated with the electric driven hydraulic fracking system.**

**19. The electric driven hydraulic fracking system of claim 16, further comprises: a black start generator that is configured to:**

**generate the electric power at a black start voltage level, wherein the electric power generated at the black start voltage level is a voltage level that is less than the power generation voltage level; and**

**provide the electric power at the black start voltage level to the power distribution trailer to distribute the electric power at the black start voltage level to each of the single VFDs positioned on each of the single pump trailers, wherein the electric power at the black start voltage level powers each of the single VFDs when the power generation system is not generating the electric power at the power generation voltage level.**

**20. The electric driven hydraulic fracking system of claim 16, wherein the power distribution trailer comprises:**

**a power distribution trailer controller that is configured to operate as a gateway of data generated by the single VFD and the power generation system to enable a fracking control center associated with the electric driven hydraulic fracking system to monitor the operation of the single VFD, the single shaft electric motor, the single hydraulic pump, and the trailer auxiliary systems.**

**21. An electric driven hydraulic fracking system pumps a fracking media into a fracking well to execute a fracking operation to extract a fluid from the fracking well, comprising:**

a power generation system that is configured to generate electric power at a power generation voltage level;

a power distribution trailer that is configured to:

distribute the electric power generated by the power generation system at the power generation voltage level to a variable frequency drive (VFD), wherein the VFD converts the electric power at the power generation level to a VFD voltage level to control an operation of an electric motor and a hydraulic pump,

convert the electric power generated by the power generation system at the power generation voltage level to a plurality of different voltage levels that is less than the power generation voltage level, and

distribute the electric power at each different voltage level to a corresponding system from a plurality of systems included in the electric driven hydraulic fracking system, wherein the electric power at each different voltage level controls an operation of each corresponding system included in the electric driven hydraulic fracking system.

22. The electric driven hydraulic fracking system of claim 21, wherein the power distribution trailer comprises:

an auxiliary system transformer that is configured to:

convert the electric power generated by the power generation system at the power generation voltage level to an auxiliary voltage level that is less than the power generation voltage level, and

distribute the electric power at the auxiliary voltage level to the VFD, wherein the electric power at the auxiliary voltage level enables the VFD to communicate with a fracking control center.

23. The electric driven hydraulic fracking system of claim 22, wherein the auxiliary system transformer is further configured to:

distribute the electric power at the auxiliary voltage level to a plurality of auxiliary systems associated with the hydraulic pump, wherein the plurality of auxiliary systems assists the hydraulic pump as the hydraulic pump operates to execute the fracking operation

to extract fluid from the well.

24. The electric driven hydraulic fracking system of claim 23, wherein the auxiliary systems comprise one or more of hydration systems, chemical additive systems, blending systems, sand storage and transporting systems, and mixing systems.

25. The electric driven hydraulic fracking system of claim 22, wherein the power distribution trailer further comprises:

an additional system transformer that is configured to:

convert the electric power generated at the power generation voltage level to an additional voltage level that is less than the power generation voltage level and differs from the auxiliary voltage level, and

distribute the electric power at the additional voltage level to a plurality of additional systems associated with the electric driven hydraulic fracking system, wherein the electric power at the additional voltage level controls an operation of each additional system associated with the electric driven hydraulic fracking system.

26. The electric driven hydraulic fracking system of claim 21, wherein the power distribution trailer is further configured to:

receive electric power at a black start voltage level generated by a black start generator, wherein the electric power generated at the black start voltage level is a voltage level that is less than the power generation voltage level; and

distribute the electric power at the black start voltage level to the VFD, wherein the electric power at the black start voltage level powers the VFD when the power generation system is not generating the electric power at the power generation voltage level.

27. The electric driven hydraulic fracking system of claim 21, wherein the power distribution trailer is further configured to:

receive the electric power at a power generation level of 24MW and 12.47kV from an electric utility power plant, wherein the electric utility power plant is a power plant that independently generates electric power for an electric utility grid;

distribute the electric power at the power generation level of 24MW and 12.47kV

to the VFD, wherein the VFD converts the electric power at the power generation level of 24MW and 12.47kV to the VFD voltage level to control the operation of the electric motor and the hydraulic pump;

convert the electric power generated by the electric utility power plant at the power generation voltage level of 24MW and 12.47kV to the plurality of different voltage levels that is less than the power generation voltage level of 24MW and 12.47kV; and

distribute the electric power at each different voltage level to the corresponding system from the plurality of systems included in the electric driven hydraulic fracking system.

28. The electric driven hydraulic fracking system of claim 21, wherein the power distribution trailer controller is further configured to:

receive the electric power at a power generation level of 24MW to 32MW and 13.8kV from a plurality of gas turbine engines, wherein the plurality of gas turbine engines enables the electric driven hydraulic fracking system to operate in an island mode to provide the electric driven hydraulic fracking system with the electric power to operate;

distribute electric power at the power generation level of 24MW to 32MW and 13.8kV to the VFD, wherein the VFD converts the electric power at the power generation level of 24MW to 32MW, wherein the VFD converts the electric power at the power generation level of 24MW to 32MW and 13.8kV to the VFD voltage level to control the operation of the electric motor and the hydraulic pump;

convert the electric power generated by the plurality of gas turbine engines at the power generation voltage level of 24MW to 32MW and 13.8kV to the plurality of different voltage levels that is less than the power generation voltage level of 24MW to 32MW and

13.8kV; and

distribute the electric power at each different voltage level to the corresponding system from the plurality of systems included in the electric driven hydraulic fracking system.

29. A method for an electric driven hydraulic fracking system to pump a fracking media into a well to execute a fracking operation to extract a fluid from the well, comprising:

generating electric power by a power generation system at a power generation

voltage level;

distributing by a power distribution trailer the electric power at the power generation voltage level to a variable frequency drive (VFD), wherein the VFD converts the electric power at the power generation level to a VFD voltage level to control an operation of the electric motor and the hydraulic pump;

converting the electric power generated by the power generation system at the power generation voltage level to a plurality of different voltage levels that is less than the power generation voltage level; and

distributing the electric power at each different voltage level to a corresponding system from a plurality of systems included in the electric driven hydraulic fracking system, wherein the electric power at each different voltage level controls an operation of each corresponding system included in the electric driven hydraulic fracking system.

30. The method of claim 29, further comprising:

converting, by an auxiliary system transformer positioned on the power distribution trailer, the electric power generated by the power generation system at the power generation voltage level to an auxiliary voltage level that is less than the power generation voltage level; and

distributing the electric power at the auxiliary voltage level to the VFD, wherein the electric power at the auxiliary voltage level is less than the power generation voltage level to enable the VFD to communicate with a fracking control center.

31. The method of claim 30, further comprising:

distributing the electric power at the auxiliary voltage level to a plurality of auxiliary systems associated with the hydraulic pump, wherein the plurality of auxiliary systems assists the hydraulic pump as the hydraulic pump operates to execute the fracking operation to extract fluid from the well.

32. The method of claim 30, further comprising:

converting, by an additional system transformer positioned on the power

distribution trailer, the electric power generated at the power generation voltage level to an additional voltage level that is less than the power generation voltage level and differs from the auxiliary voltage level; and

distributing the electric power at the additional voltage level to a plurality of additional systems associated with the electric driven hydraulic fracking system, wherein the electric power at the additional voltage level controls an operation of each additional system associated with the electric driven hydraulic fracking system.

33. The method of claim 29, further comprising:

receiving electric power at a black start voltage level generated by a black start generator, wherein the electric power generated at the black start voltage level is a voltage level that is less than the power generation voltage level; and

distributing the electric power at the black start voltage level to the VFD, wherein the electric power at the black start voltage level powers the VFD when the power generation system is not generating the electric power at the power generation voltage level.

34. The method of claim 29, further comprising:

receiving the electric power at a power generation level of 24MW and 12.47kV from an electric utility power plant, wherein the electric utility power plant is a power plant that independently generates electric power for an electric utility grid;

distributing the electric power at the power generation voltage level of 24MW and 12.47kV to the VFD, wherein the VFD converts the electric power at the power generation voltage level of 24MW and 12.47kV to the VFD voltage level to control the operation of the electric motor and the hydraulic pump;

converting the electric power generated by the electric utility power plant at the power generation voltage level of 24MW and 12.47kV to the plurality of different voltage levels that is less than the power generation voltage level of 24MW and 12.47kV; and

distributing the electric power at each different voltage level to the corresponding system from the plurality of systems included in the electric driven hydraulic fracking system.

35. The method of claim 29, further comprising:

receiving the electric power at a power generation voltage level of 24MW to 32MW and 13.8kV from a plurality of gas turbine engines to enable the electric driven hydraulic fracking system to operate in an island mode, wherein the island mode enables the electric driven hydraulic fracking system to operate based on the electric power provided by the plurality of gas turbine engines;

distributing electric power at the power generation level of 24MW to 32MW and 13.8kV to the VFD, wherein the VFD converts the electric power at the power generation level of 24MW to 32MW, wherein the VFD converts the electric power at the power generation voltage level of 24MW to 32MW and 13.8kV to the VFD voltage level to control the operation of the electric motor and the hydraulic pump;

converting the electric power generated by the plurality of gas turbine engines at the power generation voltage level of 24MW to 32MW and 13.8kV to the plurality of different voltage levels that is less than the power generation voltage level of 24MW to 32MW and 13.8kV; and

distributing the electric power at each different voltage level to the corresponding system from the plurality of systems included in the electric driven hydraulic fracking system.

36. An electric driven hydraulic fracking system pumps a fracking media into a fracking well to execute a fracking operation to extract a fluid from the fracking well, comprises:

a power generation system that is configured to generate electric power at a power generation voltage level;

a power distribution trailer that is configured to:

distribute the electric power generated by the power generation system at the power generation voltage level to a plurality of variable frequency drives (VFDs), wherein each VFD converts the electric power at the power generation level to a VFD voltage level to control an operation of an electric motor from a plurality of electric motors

and a corresponding hydraulic pump from a plurality of hydraulic pumps,

convert the electric power generated by the power generation system at the power generation voltage level to a plurality of different voltage levels that is less than the power generation voltage level, and

distribute the electric power at each different voltage level to a corresponding system from a plurality of systems included in the electric driven hydraulic fracking system, wherein the electric power at each different voltage level controls an operation of each corresponding system included in the electric driven hydraulic fracking system.

37. The electric driven hydraulic fracking system of claim 36, wherein the power distribution trailer comprises:

an auxiliary system transformer that is configured to:

convert the electric power generated by the power generation system at the power generation voltage level to an auxiliary voltage level that is less than the power generation voltage level,

distribute the electric power at the auxiliary voltage level to the plurality of VFDs, wherein the electric power at the auxiliary voltage level enables the plurality of VFDs to communicate with a fracking control center, and

distribute the electric power at the auxiliary voltage level to a plurality of auxiliary systems associated with the hydraulic pump, wherein the plurality of auxiliary systems assists the hydraulic pump as the hydraulic pump operates to execute the fracking operation to extract fluid from the well.

38. The electric driven hydraulic fracking system of claim 37, wherein the auxiliary systems comprise one or more of hydration systems, chemical additive systems, blending systems, sand storage and transporting systems, and mixing systems.

39. The electric driven hydraulic fracking system of claim 37, wherein the power distribution trailer further comprises:

an additional system transformer that is configured to:

convert the electric power generated at the power generation voltage level to an additional voltage level that is less than the power generation voltage level and differs

from the auxiliary voltage level, and

distribute the electric power at the additional voltage level to a plurality of additional systems associated with the electric driven hydraulic fracking system, wherein the electric power at the additional voltage level controls an operation of each additional system associated with the electric driven hydraulic fracking system.

40. The electric driven hydraulic fracking system of claim 37, wherein the power distribution trailer is further configured to:

receive electric power at a black start voltage generated by a black start generator, wherein the electric power generated at the black start voltage level is a voltage level that is less than the power generation voltage level; and

distribute the electric power at the black start voltage level to the plurality of VFDs, wherein the electric power at the black start voltage level powers the plurality of VFDs when the power generation system is not generating the electric power at the power generation voltage level.

41. The electric driven hydraulic fracking system of claim 37, wherein the power distribution trailer is further configured to:

receive electric power at a power generation level of 24MW and 12.47kV from an electric utility power plant, wherein the electric utility power plant is a power plant that independently generates electric power for an electric utility grid;

distribute the electric power at the power generation level of 24MW and 12.47kV to the plurality of VFDs, wherein each VFD converts the electric power at the power generation level of 24MW and 12.47kV to the VFD voltage level to control the operation of the electric motor and the hydraulic pump;

convert the electric power generated by the electric utility power plant at the power generation voltage level of 24MW and 12.47kV to the plurality of different voltage levels that is less than the power generation voltage level of 24MW and 12.47kV; and

distribute the electric power at each different voltage level to the corresponding system from the plurality of systems included in the electric driven hydraulic fracking system.

42. The electric driven hydraulic fracking system of claim 37, wherein the power distribution trailer comprises:

receive the electric power at a power generation level of 24MW to 32MW and 13.8kV from a plurality of gas turbine engines enable the electric driven hydraulic fracking system to operate in an island mode, wherein the island mode enables the electric driven hydraulic fracking system to operate based on the electric power provided by the plurality of gas turbines;

distribute the electric power at the power generation level of 24MW to 32MW and 13.8kV to the plurality of VFDs, wherein each VFD converts the electric power at the power generation level of 24MW to 32MW and 13.8kV to the VFD voltage level to control the operation of the electric motor and the hydraulic pump;

convert the electric power generated by the plurality of gas turbine engines at the power generation voltage level of 24MW to 32MW and 13.8kV to the plurality of different voltage levels that is less than the power generation voltage level of 24MW to 32MW and 13.8kV; and

distribute the electric power at each different voltage level to the corresponding system from the plurality of systems included in the electric driven hydraulic fracking system.

43. An electric driven hydraulic fracking system pumps a fracking media into a fracking well to execute a fracking operation to extract a fluid from the fracking well, comprising:

a power distribution trailer that is configured to:

receive electric power at a power generation voltage level of 24MW and 12.47kV from an electric utility power plant, wherein the electric utility power plant is a power plant that independently generates power for an electric utility grid;

distribute the electric power at the power generation level of 24MW and 12.47kV to a Variable Frequency Drive (VFD), wherein the VFD converts the electric

power at the power generation level of 24MW and 12.47kV to the VFD voltage level to control the operation of the electric motor and the hydraulic pump;

convert the electric power generated by the electric utility power plant at the power generation voltage level of 24MW and 12.47kV to a plurality of different voltage levels that is less than the power generation voltage level of 24MW and 12.47kV, and

distribute the electric power at each different voltage level to a corresponding system from a plurality of systems included in the electric driven hydraulic fracking system, wherein the electric power at each different voltage level controls an operation of each corresponding system included in the electric driven hydraulic fracking system.

44. The electric driven hydraulic fracking system of claim 43, wherein the power distribution trailer comprises:

an auxiliary system transformer that is configured to:

convert the electric power generated by the power generation system at the power generation voltage level to an auxiliary voltage level that is less than the power generation voltage level, and

distribute the electric power at the auxiliary voltage level to the VFD, wherein the electric power at the auxiliary voltage level enables the VFD to communicate with a fracking control center.

45. The electric driven hydraulic fracking system of claim 44, wherein the auxiliary system transformer is further configured to:

distribute the electric power at the auxiliary voltage level to a plurality of auxiliary systems associated with the hydraulic pump, wherein the plurality of auxiliary systems assists the hydraulic pump as the hydraulic pump operates to execute the fracking operation to extract fluid from the well.

46. The electric driven hydraulic fracking system of claim 45, wherein the auxiliary systems comprise one or more of hydration systems, chemical additive

systems, blending systems, sand storage and transporting systems, and mixing systems.

47. The electric driven hydraulic fracking system of claim 45, wherein the power distribution trailer further comprises:

an additional system transformer that is configured to:

convert the electric power generated at the power generation voltage level to an additional voltage level that is less than the power generation voltage level and differs from the auxiliary voltage level, and

distribute the electric power at the additional voltage level to a plurality of additional systems associated with the electric driven hydraulic fracking system, wherein the electric power at the additional voltage level controls an operation of each additional system associated with the electric driven hydraulic fracking system.

48. The electric driven hydraulic fracking system of claim 43, wherein the power distribution trailer is further configured to:

receive electric power at a black start voltage level generated by a black start generator, wherein the electric power generated at the black start voltage level is a voltage level that is less than the power generation voltage level; and

distribute the electric power at the black start voltage level to the VFD, wherein the electric power at the black start voltage level powers the VFD when the power generation system is not generating the electric power at the power generation voltage level.

49. The electric driven hydraulic fracking system of claim 43, wherein the power distribution trailer controller is further configured to:

receive the electric power at a power generation level of 24MW to 32MW and 13.8kV from a plurality of gas turbine engines, wherein the plurality of gas turbine engines enables the electric driven hydraulic fracking system to operate in an island mode to provide the electric driven hydraulic fracking system with the electric power to operate;

distribute electric power at the power generation level of 24MW to 32MW and 13.8kV to the VFD, wherein the VFD converts the electric power at the power generation level of 24MW to 32MW, wherein the VFD converts the electric power

at the power generation level of 24MW to 32MW and 13.8kV to the VFD voltage level to control the operation of the electric motor and the hydraulic pump;

convert the electric power generated by the plurality of gas turbine engines at the power generation voltage level of 24MW to 32MW and 13.8kV to the plurality of different voltage levels that is less than the power generation voltage level of 24MW to 32MW and 13.8kV; and

distribute the electric power at each different voltage level to the corresponding system from the plurality of systems included in the electric driven hydraulic fracking system.

50. A method for an electric driven hydraulic fracking system to pump a fracking media into a well to execute a fracking operation to extract a fluid from the well, comprising:

receiving the electric power at a power generation voltage level of 24MW and 12.47kV from an electric utility power plant, wherein the electric utility power plant is a power plant that independently generates power for an electric utility grid;

distributing the electric power at the power generation voltage level of 24MW and 12.47 kV to a Variable Frequency Drive (VFD), wherein the VFD converts the electric power at the power generation level of 24MW and 12.47kV to the VFD voltage level to control the operation of the electric motor and the hydraulic pump;

converting the electric power generated by the electric utility power plant at the power generation voltage level of 24MW and 12.47kV to a plurality of different voltage levels of 24MW and 12.47kV that is less than the power generation voltage level; and

distributing the electric power at each different voltage level to a corresponding system from a plurality of systems included in the electric driven hydraulic fracking system, wherein the electric power at each different voltage level controls an operation of each corresponding system included in the electric driven hydraulic fracking system.

51. The method of claim 50, further comprising:

converting, by an auxiliary system transformer positioned on the power distribution trailer, the electric power generated by the power generation system at the power generation voltage level to an auxiliary voltage level that is less than the power

generation voltage level; and

distributing the electric power at the auxiliary voltage level to the VFD, wherein the electric power at the auxiliary voltage level is less than the power generation voltage level to enable the VFD to communicate with a fracking control center.

52. The method of claim 51, further comprising:

distributing the electric power at the auxiliary voltage level to a plurality of auxiliary systems associated with the hydraulic pump, wherein the plurality of auxiliary systems assists the hydraulic pump as the hydraulic pump operates to execute the fracking operation to extract fluid from the well.

53. The method of claim 51, further comprising:

converting, by an additional system transformer positioned on the power distribution trailer, the electric power generated at the power generation voltage level to an additional voltage level that is less than the power generation voltage level and differs from the auxiliary voltage level; and

distributing the electric power at the additional voltage level to a plurality of additional systems associated with the electric driven hydraulic fracking system, wherein the electric power at the additional voltage level controls an operation of each additional system associated with the electric driven hydraulic fracking system.

54. The method of claim 50, further comprising:

receiving electric power at a black start voltage level generated by a black start generator, wherein the electric power generated at the black start voltage level is a voltage level that is less than the power generation voltage level; and

distributing the electric power at the black start voltage level to the VFD, wherein the electric power at the black start voltage level powers the VFD when the power generation system is not generating the electric power at the power generation voltage level.

55. The method of claim 50, further comprising:

receiving the electric power at a power generation level of 24MW and 12.47kV

from an electric utility power plant, wherein the electric utility power plant is a power plant that independently generates electric power for an electric utility grid;

distributing the electric power at the power generation voltage level of 24MW and 12.47kV to the VFD, wherein the VFD converts the electric power at the power generation voltage level of 24MW and 12.47kV to the VFD voltage level to control the operation of the electric motor and the hydraulic pump;

converting the electric power generated by the electric utility power plant at the power generation voltage level of 24MW and 12.47kV to the plurality of different voltage levels that is less than the power generation voltage level of 24MW and 12.47kV; and

distributing the electric power at each different voltage level to the corresponding system from the plurality of systems included in the electric driven hydraulic fracking system.

56. The method of claim 50, further comprising:

receiving the electric power at a power generation voltage level of 24MW to 32MW and 13.8kV from a plurality of gas turbine engines to enable the electric driven hydraulic fracking system to operate in an island mode, wherein the island mode enables the electric driven hydraulic fracking system to operate based on the electric power provided by the plurality of gas turbine engines;

distributing electric power at the power generation level of 24MW to 32MW and 13.8kV to the VFD, wherein the VFD converts the electric power at the power generation level of 24MW to 32MW, wherein the VFD converts the electric power at the power generation voltage level of 24MW to 32MW and 13.8kV to the VFD voltage level to control the operation of the electric motor and the hydraulic pump;

converting the electric power generated by the plurality of gas turbine engines at the power generation voltage level of 24MW to 32MW and 13.8kV to the plurality of different voltage levels that is less than the power generation voltage level of 24MW to 32MW and 13.8kV; and

distributing the electric power at each different voltage level to the corresponding system from the plurality of systems included in the electric driven hydraulic fracking system.

57. An electric driven hydraulic fracking system pumps a fracking media into a fracking well to execute a fracking operation to extract a fluid from the fracking well, comprises:

a power distribution trailer that is configured to:

receive electric power at a power generation voltage level of 24MW and 12.47kV from an electric utility power plant, wherein the electric utility power plant is a power plant that independently generates electric power for an electric utility grid,

distribute the electric power at the power generation voltage level of 14MW and 12.47kV to a plurality of VFDs, wherein each VFD converts the electric power at the power generation voltage level of 24MW and 12.47kV to the VFD voltage level to control the operation of the electric motor and the hydraulic pump,

convert the electric power generated by the electric utility power plant at the power generation voltage level 24MW and 12.47kV to a plurality of different voltage levels that is less than the power generation voltage level of 24MW and 12.47kV, and

distribute the electric power at each different voltage level to a corresponding system from a plurality of systems included in the electric driven hydraulic fracking system, wherein the electric power at each different voltage level controls an operation of each corresponding system included in the electric driven hydraulic fracking system.

58. The electric driven hydraulic fracking system of claim 57, wherein the power distribution trailer comprises:

an auxiliary system transformer that is configured to:

convert the electric power generated by the power generation system at the power generation voltage level to an auxiliary voltage level that is less than the power generation voltage level,

distribute the electric power at the auxiliary voltage level to the plurality of VFDs, wherein the electric power at the auxiliary voltage level enables the plurality of VFDs to communicate with a fracking control center, and

distribute the electric power at the auxiliary voltage level to a plurality of auxiliary systems associated with the hydraulic pump, wherein the plurality of auxiliary systems assists the hydraulic pump as the hydraulic pump operates to execute the fracking operation to extract fluid from the well.

59. The electric driven hydraulic fracking system of claim 58, wherein the auxiliary systems comprise one or more of hydration systems, chemical additive systems, blending systems, sand storage and transporting systems, and mixing systems.

60. The electric driven hydraulic fracking system of claim 58, wherein the power distribution trailer further comprises:

an additional system transformer that is configured to:

convert the electric power generated at the power generation voltage level to an additional voltage level that is less than the power generation voltage level and differs from the auxiliary voltage level, and

distribute the electric power at the additional voltage level to a plurality of additional systems associated with the electric driven hydraulic fracking system, wherein the electric power at the additional voltage level controls an operation of each additional system associated with the electric driven hydraulic fracking system.

61. The electric driven hydraulic fracking system of claim 57, wherein the power distribution trailer is further configured to:

receive electric power at a black start voltage generated by a black start generator, wherein the electric power generated at the black start voltage level is a voltage level that is less than the power generation voltage level; and

distribute the electric power at the black start voltage level to the plurality of VFDs, wherein the electric power at the black start voltage level powers the plurality of VFDs when the power generation system is not generating the electric power at the power generation voltage level.

62. The electric driven hydraulic fracking system of claim 57, wherein the power

distribution trailer comprises:

receive the electric power at a power generation level of 24MW to 32MW and 13.8kV from a plurality of gas turbine engines enable the electric driven hydraulic fracking system to operate in an island mode, wherein the island mode enables the electric driven hydraulic fracking system to operate based on the electric power provided by the plurality of gas turbines;

distribute the electric power at the power generation level of 24MW to 32MW and 13.8kV to the plurality of VFDs, wherein each VFD converts the electric power at the power generation level of 24MW to 32MW and 13.8kV to the VFD voltage level to control the operation of the electric motor and the hydraulic pump;

convert the electric power generated by the plurality of gas turbine engines at the power generation voltage level of 24MW to 32MW and 13.8kV to the plurality of different voltage levels that is less than the power generation voltage level of 24MW to 32MW and 13.8kV; and

distribute the electric power at each different voltage level to the corresponding system from the plurality of systems included in the electric driven hydraulic fracking system.

63. An electric driven hydraulic fracking system pumps a fracking media into a fracking well to execute a fracking operation to extract a fluid from the fracking well, comprising:

a power distribution trailer that is configured to:

receive electric power at a power generation voltage level of 24MW to 32MW and 13.8kV from a plurality of gas turbine engines, wherein the plurality of gas turbine engines enables the electric driven hydraulic fracking system to operate in an island mode to provide the electric driven hydraulic fracking system with the electric power to operate,

distribute the electric power at the power generation level of 24MW to 32MW and 13.8kV to a Variable Frequency Drive (VFD), wherein the VFD converts the electric power at the power generation level of 24MW to 32MW and 13.8kV to the VFD voltage level to control an operation of the electric motor and the hydraulic pump,

convert the electric power generated by the plurality of gas turbine engines at the power generation voltage level of 24MW to 32MW and 13.8kV to a plurality of different voltage levels that is less than the power generation voltage level of 24MW to 32MW and 13.8kV, and

distribute the electric power at each different voltage level to a corresponding system from a plurality of systems included in the electric driven hydraulic fracking system, wherein the electric power at each different voltage level controls an operation of each corresponding system included in the electric driven hydraulic fracking system.

64. The electric driven hydraulic fracking system of claim 64, wherein the power distribution trailer comprises:

an auxiliary system transformer that is configured to:

convert the electric power generated by the power generation system at the power generation voltage level to an auxiliary voltage level that is less than the power generation voltage level, and

distribute the electric power at the auxiliary voltage level to the VFD, wherein the electric power at the auxiliary voltage level enables the VFD to communicate with a fracking control center.

65. The electric driven hydraulic fracking system of claim 64, wherein the auxiliary system transformer is further configured to:

distribute the electric power at the auxiliary voltage level to a plurality of auxiliary systems associated with the hydraulic pump, wherein the plurality of auxiliary systems assists the hydraulic pump as the hydraulic pump operates to execute the fracking operation to extract fluid from the well.

66. The electric driven hydraulic fracking system of claim 65, wherein the auxiliary systems comprise one or more of hydration systems, chemical additive systems, blending systems, sand storage and transporting systems, and mixing systems.

67. The electric driven hydraulic fracking system of claim 65, wherein the power distribution trailer further comprises:

an additional system transformer that is configured to:

convert the electric power generated at the power generation voltage level to an additional voltage level that is less than the power generation voltage level and differs from the auxiliary voltage level, and

distribute the electric power at the additional voltage level to a plurality of additional systems associated with the electric driven hydraulic fracking system, wherein the electric power at the additional voltage level controls an operation of each additional system associated with the electric driven hydraulic fracking system.

68. The electric driven hydraulic fracking system of claim 63, wherein the power distribution trailer is further configured to:

receive electric power at a black start voltage level generated by a black start generator, wherein the electric power generated at the black start voltage level is a voltage level that is less than the power generation voltage level; and

distribute the electric power at the black start voltage level to the VFD, wherein the electric power at the black start voltage level powers the VFD when the power generation system is not generating the electric power at the power generation voltage level.

69. The electric driven hydraulic fracking system of claim 63, wherein the power distribution trailer is further configured to:

receive the electric power at a power generation level of 24MW and 12.47kV from an electric utility power plant, wherein the electric utility power plant is a power plant that independently generates electric power for an electric utility grid;

distribute the electric power at the power generation level of 24MW and 12.47kV to the VFD, wherein the VFD converts the electric power at the power generation level of 24MW and 12.47kV to the VFD voltage level to control the operation of the electric motor and the hydraulic pump;

convert the electric power generated by the electric utility power plant at the power

generation voltage level of 24MW and 12.47kV to the plurality of different voltage levels that is less than the power generation voltage level of 24MW and 12.47kV; and

distribute the electric power at each different voltage level to the corresponding system from the plurality of systems included in the electric driven hydraulic fracking system.

70. A method for an electric driven hydraulic fracking system to pump a fracking media into a well to execute a fracking operation to extract a fluid from the well, comprising:

receiving electric power at a power generation voltage level of 24MW to 32MW and 13.8kV from a plurality of gas turbine engines, wherein the plurality of gas turbine engines enables the electric driven hydraulic fracking system to operate in an island mode to provide the electric driven hydraulic fracking system with the electric power to operate;

distributing the electric power at the power generation voltage level of 24MW to 32MW and 13.8kV to a Variable Frequency Drive (VFD), wherein the VFD converts electric power at the power generation voltage level of 24MW to 32MW and 13.8kV to the VFD voltage level to control an operation of the electric motor and the hydraulic pump; converting the electric power generated by the plurality of gas turbine engines at the power generation voltage level 24MW to 32MW and 13.8kV to a plurality of different voltage levels that is less than the power generation voltage level of 24MW to 32MW and 13.8kV; and

distributing the electric power at each different voltage level to a corresponding system from a plurality of systems included in the electric driven hydraulic fracking system, wherein the electric power at each different voltage level controls an operation of each corresponding system included in the electric driven hydraulic fracking system.

71. The method of claim 70, further comprising:

converting, by an auxiliary system transformer positioned on the power distribution trailer, the electric power generated by the power generation system at the power generation voltage level to an auxiliary voltage level that is less than the power generation voltage level; and

distributing the electric power at the auxiliary voltage level to the VFD, wherein the electric power at the auxiliary voltage level is less than the power generation voltage level to enable the VFD to communicate with a fracking control center.

72. The method of claim 71, further comprising:

distributing the electric power at the auxiliary voltage level to a plurality of auxiliary systems associated with the hydraulic pump, wherein the plurality of auxiliary systems assists the hydraulic pump as the hydraulic pump operates to execute the fracking operation to extract fluid from the well.

73. The method of claim 71, further comprising:

converting, by an additional system transformer positioned on the power distribution trailer, the electric power generated at the power generation voltage level to an additional voltage level that is less than the power generation voltage level and differs from the auxiliary voltage level; and

distributing the electric power at the additional voltage level to a plurality of additional systems associated with the electric driven hydraulic fracking system, wherein the electric power at the additional voltage level controls an operation of each additional system associated with the electric driven hydraulic fracking system.

74. The method of claim 70, further comprising:

receiving electric power at a black start voltage level generated by a black start generator, wherein the electric power generated at the black start voltage level is a voltage level that is less than the power generation voltage level; and

distributing the electric power at the black start voltage level to the VFD, wherein the electric power at the black start voltage level powers the VFD when the power generation system is not generating the electric power at the power generation voltage level.

75. The method of claim 70, further comprising:

receiving the electric power at a power generation level of 24MW and 12.47kV from an electric utility power plant, wherein the electric utility power plant is a power plant

that independently generates electric power for an electric utility grid;

distributing the electric power at the power generation voltage level of 24MW and 12.47kV to the VFD, wherein the VFD converts the electric power at the power generation voltage level of 24MW and 12.47kV to the VFD voltage level to control the operation of the electric motor and the hydraulic pump;

converting the electric power generated by the electric utility power plant at the power generation voltage level of 24MW and 12.47kV to the plurality of different voltage levels that is less than the power generation voltage level of 24MW and 12.47kV; and

distributing the electric power at each different voltage level to the corresponding system from the plurality of systems included in the electric driven hydraulic fracking system.

76. An electric driven hydraulic fracking system pumps a fracking media into a fracking well to execute a fracking operation to extract a fluid from the fracking well, comprises:

a power distribution trailer that is configured to:

receive electric power at a power generation voltage level of 24MW to 32MW and 13.8kV from a plurality of gas turbine engines, wherein the plurality of gas turbine engines enables the electric driven hydraulic fracking system to operate in an island mode to provide the electric driven hydraulic fracking system with the electric power to operate,

distribute the electric power at the power generation voltage level of 24MW to 32MW and 13.8kV to a plurality of Variable Frequency Drives (VFDs), wherein each VFD converts the electric power at the power generation voltage level of 24MW to 32MW and 13.8kV to a VFD voltage level to control an operation of an electric motor from a plurality of electric motors and a corresponding hydraulic pump from a plurality of hydraulic pumps,

convert the electric power generated by the plurality of gas turbine engines at the power generation voltage level of 24MW to 32MW and 13.8kV to a plurality of different voltage levels that is less than the power generation voltage level of 24MW to 32MW and 13.8kV, and

distribute the electric power at each different voltage level to a corresponding system from a plurality of systems included in the electric driven hydraulic fracking system, wherein the electric power at each different voltage level controls an operation of each corresponding system included in the electric driven hydraulic fracking system.

77. The electric driven hydraulic fracking system of claim 76, wherein the power distribution trailer comprises:

an auxiliary system transformer that is configured to:

convert the electric power generated by the power generation system at the power generation voltage level to an auxiliary voltage level that is less than the power generation voltage level,

distribute the electric power at the auxiliary voltage level to the plurality of VFDs, wherein the electric power at the auxiliary voltage level enables the plurality of VFDs to communicate with a fracking control center, and

distribute the electric power at the auxiliary voltage level to a plurality of auxiliary systems associated with the hydraulic pump, wherein the plurality of auxiliary systems assists the hydraulic pump as the hydraulic pump operates to execute the fracking operation to extract fluid from the well.

78. The electric driven hydraulic fracking system of claim 77, wherein the auxiliary systems comprise one or more of hydration systems, chemical additive systems, blending systems, sand storage and transporting systems, and mixing systems.

79. The electric driven hydraulic fracking system of claim 77, wherein the power distribution trailer further comprises:

an additional system transformer that is configured to:

convert the electric power generated at the power generation voltage level to an additional voltage level that is less than the power generation voltage level and differs from the auxiliary voltage level, and

distribute the electric power at the additional voltage level to a plurality of

additional systems associated with the electric driven hydraulic fracking system, wherein the electric power at the additional voltage level controls an operation of each additional system associated with the electric driven hydraulic fracking system.

80. The electric driven hydraulic fracking system of claim 77, wherein the power distribution trailer is further configured to:

receive electric power at a black start voltage generated by a black start generator, wherein the electric power generated at the black start voltage level is a voltage level that is less than the power generation voltage level; and

distribute the electric power at the black start voltage level to the plurality of VFDs, wherein the electric power at the black start voltage level powers the plurality of VFDs when the power generation system is not generating the electric power at the power generation voltage level.

81. The electric driven hydraulic fracking system of claim 77, wherein the power distribution trailer is further configured to:

receive electric power at a power generation level of 24MW and 12.47kV from an electric utility power plant, wherein the electric utility power plant is a power plant that independently generates electric power for an electric utility grid;

distribute the electric power at the power generation level of 24MW and 12.47kV to the plurality of VFDs, wherein each VFD converts the electric power at the power generation level of 24MW and 12.47kV to the VFD voltage level to control the operation of the electric motor and the hydraulic pump;

convert the electric power generated by the electric utility power plant at the power generation voltage level of 24MW and 12.47kV to the plurality of different voltage levels that is less than the power generation voltage level of 24MW and 12.47kV; and

distribute the electric power at each different voltage level to the corresponding system from the plurality of systems included in the electric driven hydraulic fracking system.

82. An electric driven hydraulic fracking system that pumps a fracking media into a fracking well to execute a fracking operation to extract a fluid from the fracking well, comprising:

a power distribution trailer that is configured to receive electric power from a power generation system at a power generation voltage level, wherein the electric power generated at the power generation voltage level is a voltage level that the power generation system is capable to generate; and

the power distribution trailer includes an auxiliary system transformer that is configured to:

convert the electric power generated by the power generation system at the power generation voltage level to an auxiliary voltage level that is less than the power generation voltage level,

distribute the electric power at the auxiliary voltage level to a Variable Frequency Drive (VFD), wherein the electric power at the auxiliary voltage level enables the VFD to execute operations without the distribution of the electric power generated at the power generation voltage level to the VFD thereby activating the VFD into a maintenance mode, and

distribute the electric power at the auxiliary voltage level to a plurality of auxiliary systems when the VFD is operating in the maintenance mode to enable the plurality of auxiliary systems to operate with the VFD operating in the maintenance mode, wherein the electric power at the auxiliary voltage level enables operation of the plurality of auxiliary systems when the VFD is prevented from converting the electric power at the power generation voltage level to continuously drive a hydraulic pump.

83. The electric driven hydraulic fracking system of claim 82, wherein the auxiliary system transformer is further configured to distribute the electric power at the auxiliary voltage level to the VFD to enable the VFD to communicate with a fracking control center without the distribution of the electric power generated at the power generation voltage level to the VFD.

84. The electric driven hydraulic fracking system of claim 82, wherein the auxiliary

system transformer is further configured to:

distribute the electric power at the auxiliary voltage level to the plurality of auxiliary systems associated with an operation of a hydraulic pump that is driven by the electric power at the power generation voltage level, wherein the plurality of auxiliary systems assists the hydraulic pump as the hydraulic pump operates to execute the fracking operation to extract fluid from the well when the electric power at the power generation voltage level is distributed to drive the hydraulic pump.

85. The electric driven hydraulic fracking system of claim 82, wherein the auxiliary systems comprise one or more of hydration systems, chemical additive systems, blending systems, sand storage and transporting systems, and mixing systems.

86. The electric driven hydraulic fracking system of claim 83, wherein the power distribution trailer is further configured to route a communication link to each of the auxiliary systems to enable the fracking control center to intervene and control each of the auxiliary systems via the communication link.

87. The electric driven hydraulic fracking system of claim 83, wherein the power distribution trailer is further configured to:

distribute the electric power at the auxiliary voltage level to a fracking control center to enable the fracking control center to remotely control the auxiliary systems, the VFD, and a plurality of trailer auxiliary systems, wherein the VFD and the hydraulic pump are positioned on a single trailer and the plurality of trailer auxiliary systems is associated with the single trailer.

88. The electric driven hydraulic fracking system of claim 87, wherein the power distribution trailer is further configured to route a communication link to the VFD and each of the trailer auxiliary systems to enable the fracking control center to intervene and control the VFD and each of the trailer auxiliary systems via the communication link.

89. A method for an electric driven hydraulic fracking system to pump a fracking media into a well to execute a fracking operation to extract a fluid from a well, comprising:

receiving electric power at a power generation voltage from a power generation system, wherein the electric power generated at the power generation voltage level is a voltage level that the power generation system is capable to generate;

converting the electric power generated by the power generation system at the power generation voltage level to an auxiliary voltage level that is less than the power generation voltage level;

distributing the electric power at the auxiliary voltage level to a Variable Frequency Drive (VFD), wherein the electric power at the auxiliary voltage level enables the VFD to execute operations without the distribution of the electric power generated at the power generation voltage level to the VFD thereby activating the VFD into a maintenance mode; and

distributing the electric power at the auxiliary voltage level to a plurality of auxiliary systems when the VFD is operating in the maintenance mode to enable the plurality of auxiliary systems to operate with the VFD operating in the maintenance mode, wherein the electric power at the auxiliary voltage level enables operation of the plurality of auxiliary systems when the VFD is prevented from converting the electric power at the power generation voltage level to continuously drive a hydraulic pump.

90. The method of claim 89, wherein the distributing comprises:

distributing the electric power at the auxiliary voltage level to the VFD to enable the VFD to communicate with a fracking control center without the distribution of the electric power generated at the power generation voltage level to the VFD.

91. The method of claim 89, wherein the distributing comprises:

distributing the electric power at the auxiliary voltage level to the plurality of auxiliary systems associated with an operation of a hydraulic pump that is driven by the electric power at the power generation voltage level, wherein the plurality of auxiliary systems assist the hydraulic pump as the hydraulic pump operates to execute the fracking operation to extract fluid from the well when the electric power at the power generation voltage level is distributed to drive the hydraulic pump.

92. The method of claim 89, wherein the auxiliary systems comprise one or more of hydration systems, chemical additive systems, blending systems, sand storage and transporting systems, and mixing systems.

93. The method of claim 90, further comprising:

routing a communication link to each of the auxiliary systems to enable a fracking control center to intervene and control each of the auxiliary systems via the communication link.

94. The method of claim 90, further comprising:

distributing the electric power at the auxiliary voltage level to the fracking control center to enable the fracking control center to remotely control the auxiliary systems, the VFD, and the a plurality of trailer auxiliary systems, wherein the VFD and the hydraulic pump are positioned on a single trailer and the plurality of trailer auxiliary systems is associated with the single trailer.

95. The method of claim 94, further comprising:

routing a communication link to the VFD and each of the trailer auxiliary systems to enable the fracking control center to intervene and control the VFD and each of the trailer auxiliary systems via the communication link.

96. An electric driven hydraulic fracking system that pumps a fracking media into a fracking well to execute a fracking operation to extract a fluid from the fracking well, comprises:

a power distribution trailer that is configured to receive electric power from a power generation system at a power generation voltage level wherein the electric power generated at the power generation voltage level is a voltage level that the power generation system is capable to generate; and

the power generation system that includes an auxiliary system transformer that is configured to:

convert the power generated by the power generation system at the power

generation voltage level to an auxiliary voltage level that is less than the power generation voltage level,

distribute the electric power at the auxiliary voltage level to a plurality of Variable Frequency Drives (VFDs), wherein the electric power at the auxiliary voltage level enables each VFD to execute operations without the distribution of the electric power generated at the power generation voltage level to each VFD thereby activating each VFD into a maintenance mode, and

distribute the electric power at the auxiliary voltage level to a plurality of auxiliary systems when each VFD is operating in the maintenance mode to enable the plurality of auxiliary systems to operate with each VFD operating in the maintenance mode, wherein the electric power at the auxiliary voltage level enables the operation of the plurality of auxiliary systems when the VFD is prevented from converting the electric power at the power generation voltage level to continuously drive each corresponding hydraulic pump.

97. The electric driven hydraulic fracking system of claim 96, wherein the auxiliary system transformer is further configured to distribute the electric power at the auxiliary voltage level to each VFD to enable each VFD to communicate with a fracking control center without the distribution of the electric power generated at the power generation voltage level to each VFD.

98. The electric driven hydraulic fracking system of claim 96, wherein the auxiliary system transformer is further configured to:

distribute the electric power at the auxiliary voltage level to the plurality of auxiliary systems associated with an operation of a plurality of hydraulic pumps with each hydraulic pump driven by the electric power at the power generation voltage level, wherein the plurality of auxiliary systems assists each hydraulic pump as each hydraulic pump operates to execute the fracking operation to extract fluid from the well when the electric power at the power generation voltage level is distributed to drive each hydraulic pump.

99. The electric driven hydraulic fracking system of claim 98, wherein the auxiliary systems comprise one or more of hydration systems, chemical additive systems, blending systems, sand storage and transporting systems, and mixing systems.

100. The electric driven hydraulic fracking system of claim 97, wherein the power distribution trailer is further configured to route a communication link to each of the auxiliary systems to enable a fracking control center to intervene and control each of the auxiliary systems via the communication link.

101. The electric driven hydraulic fracking system of claim 97, wherein the power distribution trailer is further configured to:

distribute the electric power at the auxiliary voltage level to the fracking control center to enable the fracking control center to remotely control the auxiliary systems, the plurality of VFDs, and a plurality of trailer auxiliary systems, wherein each VFD and each hydraulic pump are positioned on a corresponding single trailer and each corresponding plurality of trailer auxiliary systems is associated with each corresponding single trailer.

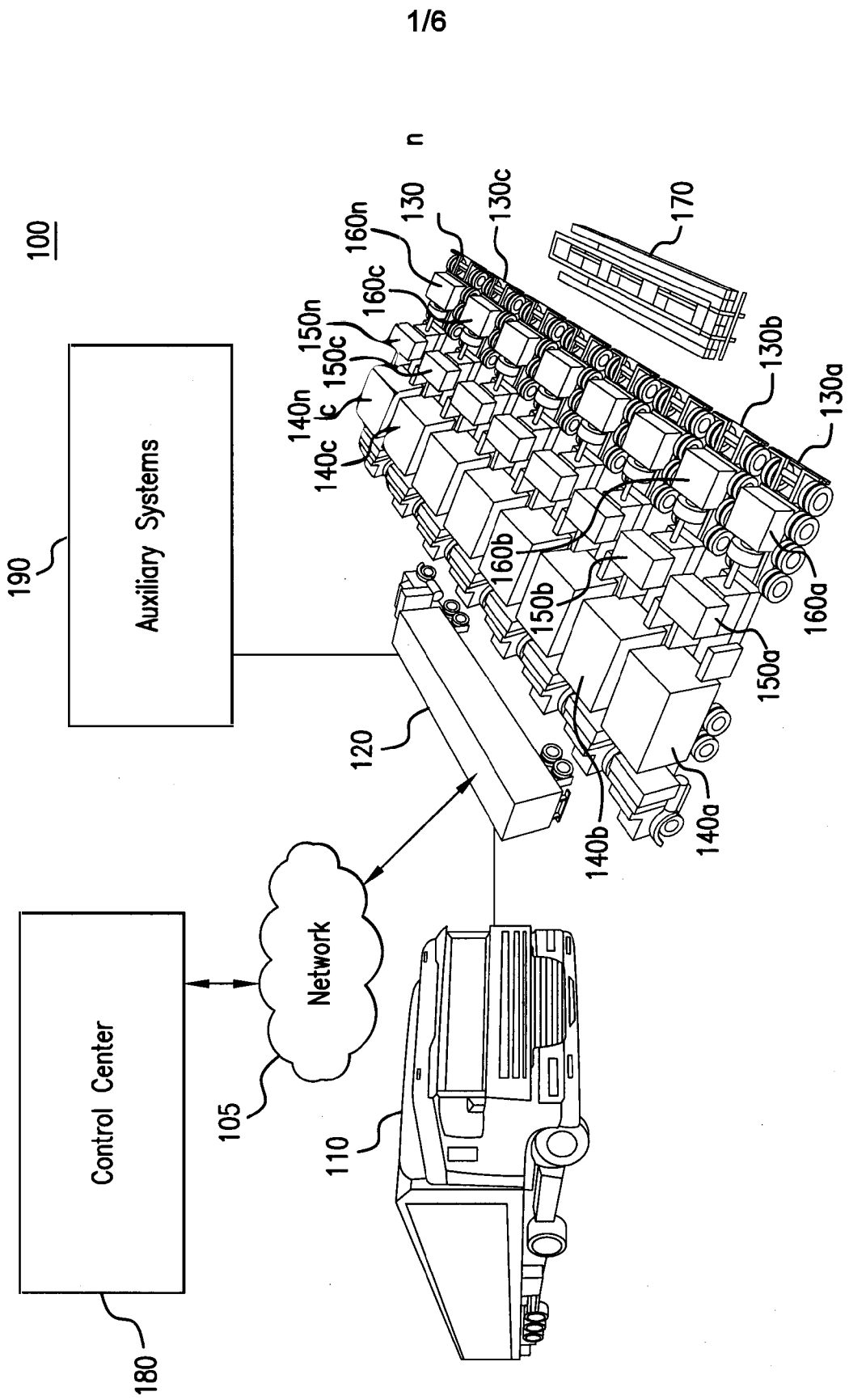

FIG.1

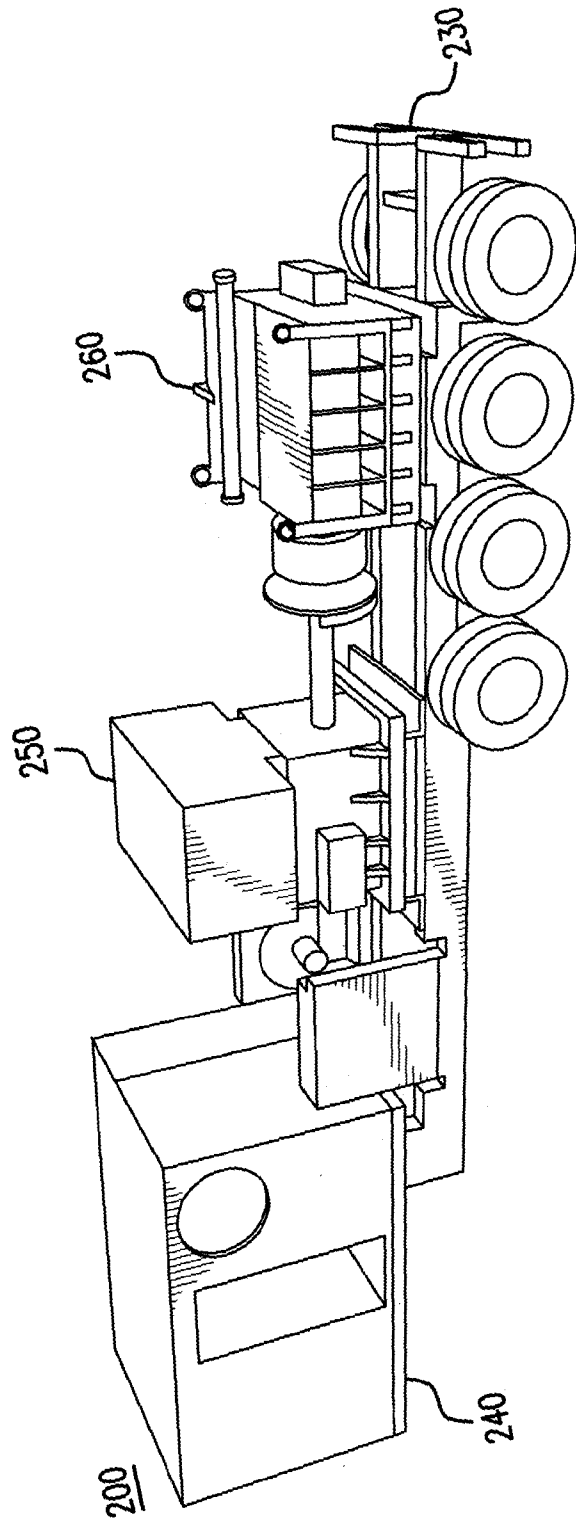

FIG. 2

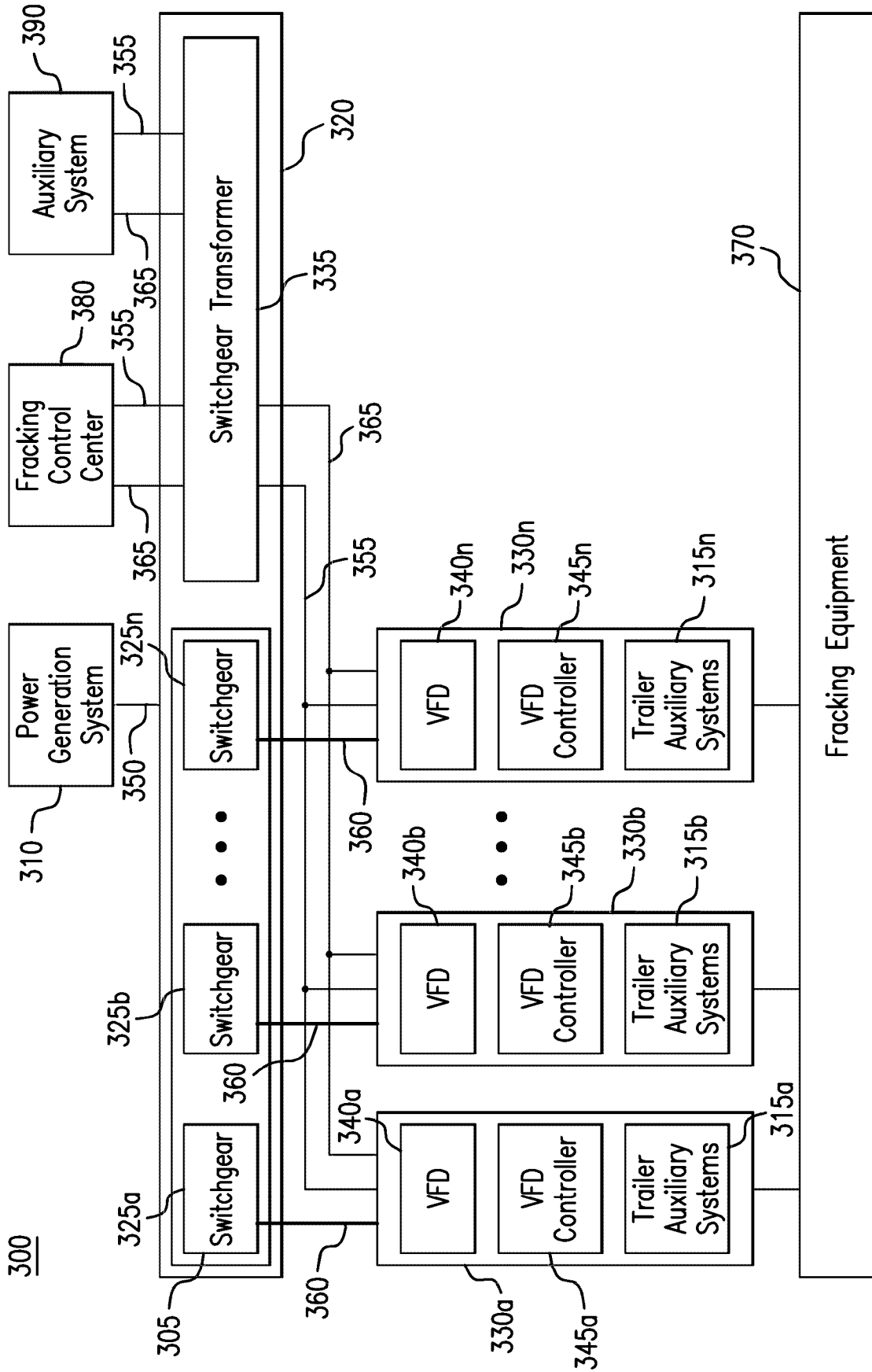

FIG.3

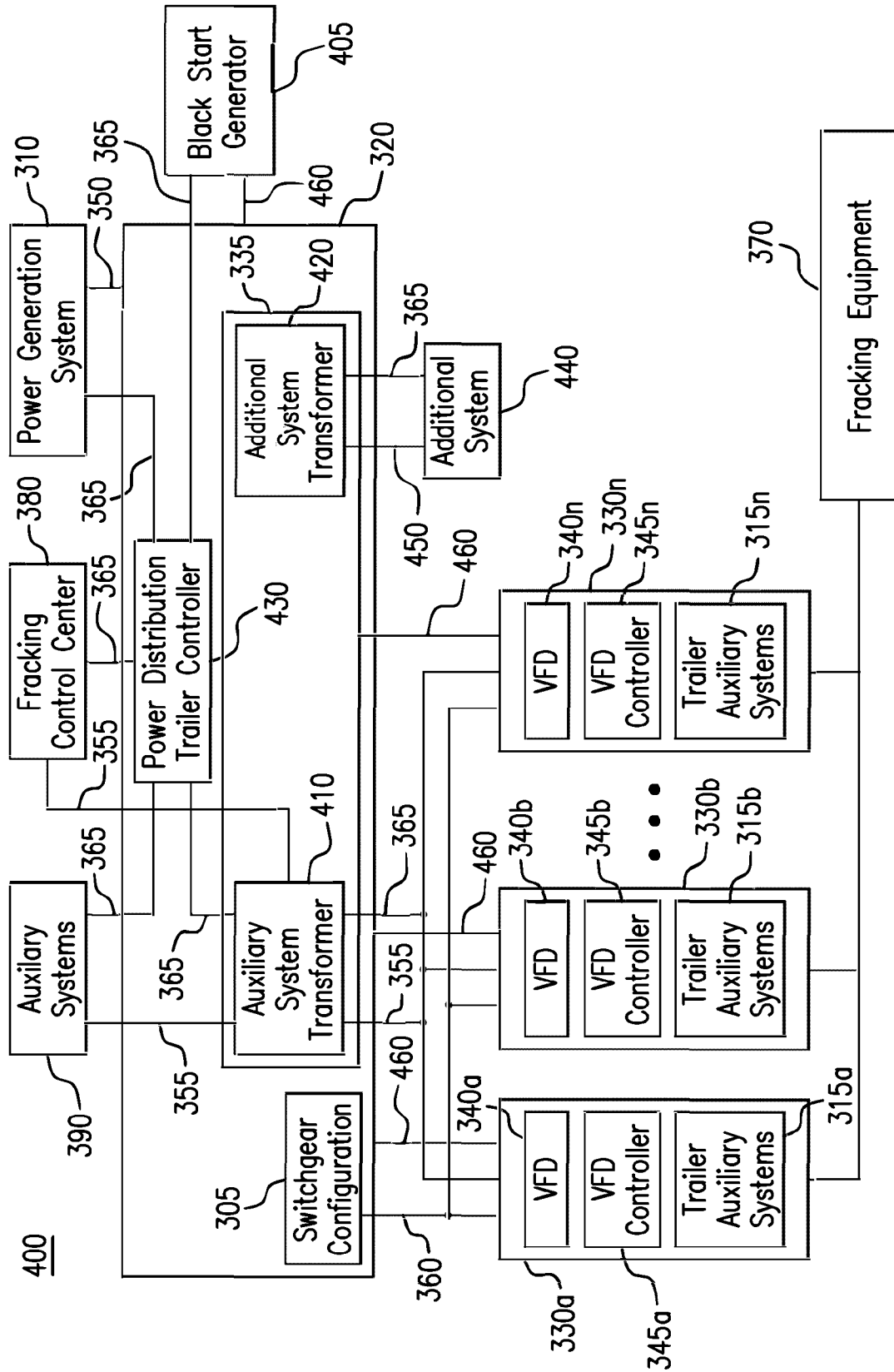

FIG. 4

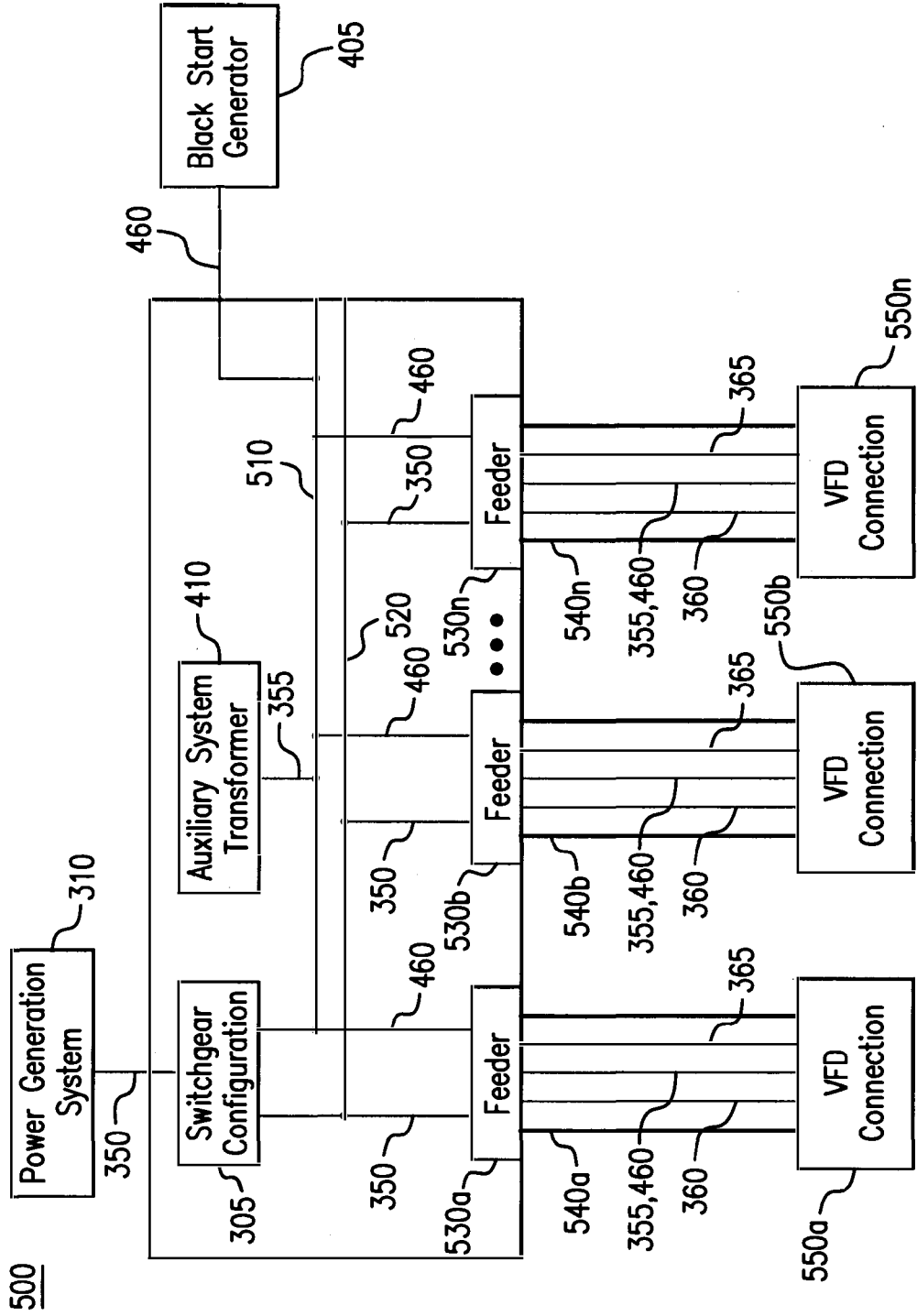

FIG. 5

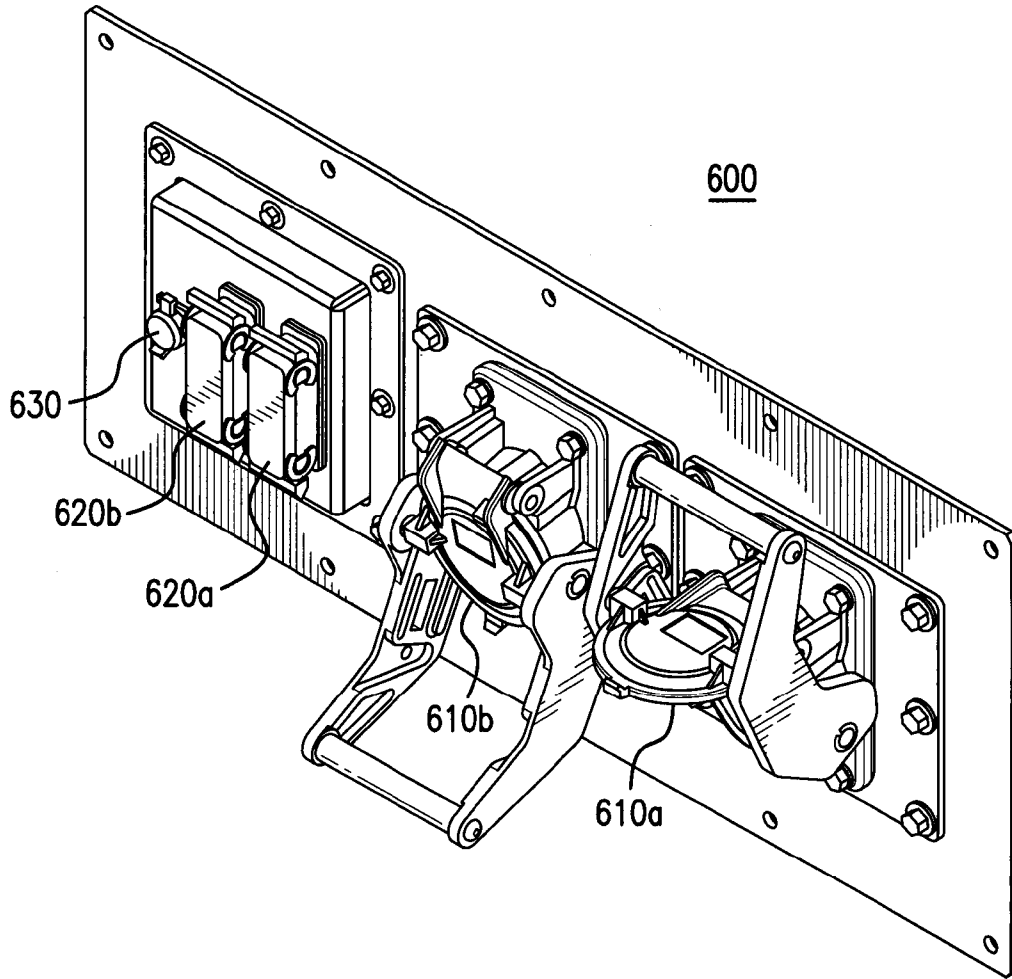

FIG.6

