

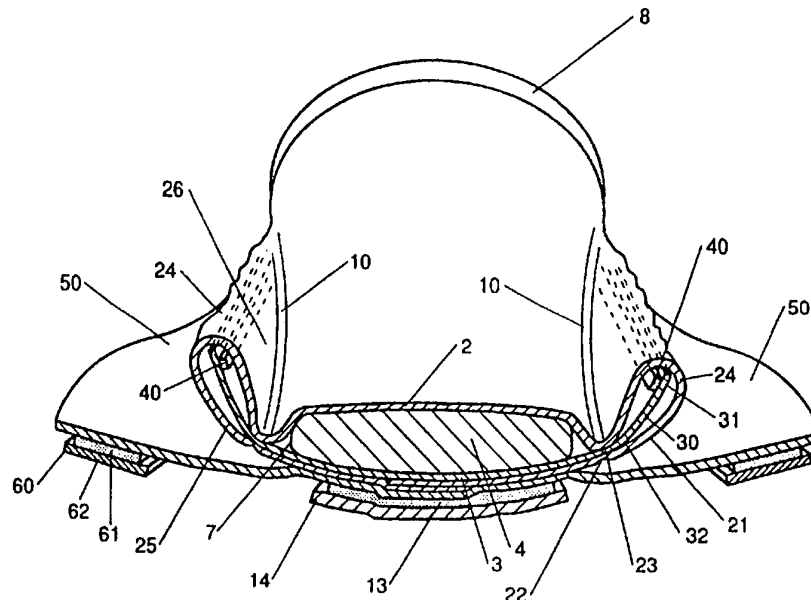

INTERNATIONAL APPLICATION PUBLISHED UNDER THE PATENT COOPERATION TREATY (PCT)

<p>(51) International Patent Classification⁵ : A61F 13/15</p>	<p>A1</p>	<p>(11) International Publication Number: WO 94/12135 (43) International Publication Date: 9 June 1994 (09.06.94)</p>
<p>(21) International Application Number: PCT/US93/11502 (22) International Filing Date: 29 November 1993 (29.11.93) (30) Priority Data: 07/984,071 30 November 1992 (30.11.92) US 08/143,780 4 November 1993 (04.11.93) US (71) Applicant: THE PROCTER & GAMBLE COMPANY [US/US]; One Procter & Gamble Plaza, Cincinnati, OH 45202 (US). (72) Inventors: MORITA, Yasuko; 1-4-3, Morigo-cho, Nada-ku, Kobe 657 (JP). SAGESER, David, Mark; 3557 Outlook Avenue, Cincinnati, OH 45208 (US). NESBITT, Daniel, Frederick; 6-7-201, Miyatsuku-cho, Ashiya, Hyogo 659 (JP). (74) Agents: REED, T., David et al.; The Procter & Gamble Company, 5299 Spring Grove Avenue, Cincinnati, OH 45202 (US).</p>	<p>(81) Designated States: AU, BB, BG, BR, BY, CA, CZ, FI, HU, JP, KP, KR, KZ, LK, LV, MG, MN, MW, NO, NZ, PL, RO, RU, SD, SK, UA, UZ, VN, European patent (AT, BE, CH, DE, DK, ES, FR, GB, GR, IE, IT, LU, MC, NL, PT, SE), OAPI patent (BF, BJ, CF, CG, CI, CM, GA, GN, ML, MR, NE, SN, TD, TG).</p> <p>Published <i>With international search report. Before the expiration of the time limit for amending the claims and to be republished in the event of the receipt of amendments.</i></p>	

(54) Title: ABSORBENT ARTICLE HAVING ELASTICIZED SIDE FLAPS AND WINGS



(57) Abstract

An absorbent article having a liquid permeable topsheet (2), a liquid impermeable backsheet (3) and a liquid absorbent pad (4) for absorbing a liquid exuded from the human body positioned therebetween, and having an elasticized side flap (20) and an extended wing (50) along each side edge of the absorbent article. The side flap has a loop member (21) formed from either the topsheet or the backsheet, or an optional secondary non-woven sheet (15), which extends from and loops back toward said side edge of said absorbent pad, and an inserted member (30) formed from a layer which extends from said side edge of said absorbent pad. An elastic material (40) is affixed along a portion of the length of the inserted member, and a seal (10) affixes the inserted member inside the loop member at its base end (22). The wing can be a separate material or can be formed from one of the layer materials used to form the elasticized flap.

FOR THE PURPOSES OF INFORMATION ONLY

Codes used to identify States party to the PCT on the front pages of pamphlets publishing international applications under the PCT.

AT	Austria	GB	United Kingdom	MR	Mauritania
AU	Australia	GE	Georgia	MW	Malawi
BB	Barbados	GN	Guinea	NE	Niger
BE	Belgium	GR	Greece	NL	Netherlands
BF	Burkina Faso	HU	Hungary	NO	Norway
BG	Bulgaria	IE	Ireland	NZ	New Zealand
BJ	Benin	IT	Italy	PL	Poland
BR	Brazil	JP	Japan	PT	Portugal
BY	Belarus	KE	Kenya	RO	Romania
CA	Canada	KG	Kyrgystan	RU	Russian Federation
CF	Central African Republic	KP	Democratic People's Republic of Korea	SD	Sudan
CG	Congo	KR	Republic of Korea	SE	Sweden
CH	Switzerland	KZ	Kazakhstan	SI	Slovenia
CI	Côte d'Ivoire	LI	Liechtenstein	SK	Slovakia
CM	Cameroon	LV	Latvia	SN	Senegal
CN	China	LU	Luxembourg	TD	Chad
CS	Czechoslovakia	LV	Latvia	TG	Togo
CZ	Czech Republic	MC	Monaco	TJ	Tajikistan
DE	Germany	MD	Republic of Moldova	TT	Trinidad and Tobago
DK	Denmark	MG	Madagascar	UA	Ukraine
ES	Spain	ML	Mali	US	United States of America
FI	Finland	MN	Mongolia	UZ	Uzbekistan
FR	France			VN	Viet Nam
GA	Gabon				

Absorbent Article Having Elasticized Side Flaps and Wings

5

FIELD OF THE INVENTION

This invention relates to an absorbent article, particularly to a sanitary article such as a sanitary napkin or an absorbing sheet. As used herein, the term "absorbent article" refers to devices which absorb and contain body exudates, and, more specifically, refers to devices which are placed against or in proximity to the body of the wearer to absorb and contain the various exudates discharged from the body.

15

BACKGROUND OF THE INVENTION

There is required for an absorbent article such as sanitary napkins or paper diapers a good and comfortable fit to the body, in addition to preventing exudates from leaking.

There has been conventionally proposed, for example, a curved sanitary napkin in which an elastic material in initial tension is arranged at the longitudinal edge of the napkin. If a sanitary napkin is formed into a curved shape by an elastic material, the body fit is enhanced, and an improvement in wearer's feeling of fit as well as the reduction of side leaking can be achieved. Such sanitary napkins are disclosed in U.S. Patent Nos. 4,668,230, 4,701,177 and 4,770,657.

In the absorbent articles disclosed in the above-mentioned U.S. Patents, an elastic material is directly or indirectly bonded to the edge of a sheet surface which contacts with the body. A seal is provided which divides the elastic material arranged at this edge and an absorbent core positioned at the center. In this conventional constitution, a curved shape is provided to an absorbent article such as a sanitary napkin by wrinkling the surface sheet and the elastic material.

However, the above-mentioned conventional absorbent article has a problem that causes an uncomfortable feeling due to a deep wrinkle caused on the surface sheet of the edge and impairs comfortableness at

35

the time of using the absorbent article in a curved shape, particularly when the surface sheet is a plastic material. Therefore, such sanitary napkins are not completely satisfactory, and there remains a need for improvement in fit, comfort, and containment by sanitary napkins and other absorbent articles.

The object of this invention is to provide an absorbent article which can enhance body fit in usage and can achieve an improvement in comfort and reduction of side leakage.

SUMMARY OF THE INVENTION

This invention provides an absorbent article comprising a wearer-facing, body-contacting liquid permeable topsheet, a garment-facing liquid impermeable backsheet, and a liquid absorbent pad there between for absorbing a liquid exuded from the human body, characterized by comprising:

- i) an elasticized side flap along each side edge of said absorbent article, said side flap comprising:
 - a loop member having a base end with an opening positioned toward the side edge of the absorbent pad, a distal end, a garment-facing portion and a wearer-facing portion;
 - an inserted member which extends through said base end opening into said loop member, and having a distal end and a base end;
 - an elastic material affixed along a portion of the length of said inserted member outboard of said base end, wherein said elastic material is not affixed to said loop member; and
 - a seal attaching said inserted member to said garment-facing and wearer-facing portions of said loop member at said respective base ends; and
- ii) a wing adjacent to and extending laterally from a line of juncture located along each side edge of said absorbent pad.

The wings can be a separate element or separate elements attached to the garment-facing side of the main body of the napkin, or can be combined in a single member which forms a portion of the wing and a portion of the elasticized side flap.

DESCRIPTION OF THE DRAWINGS

FIG. 1 shows a sanitary napkin of the present invention comprising elasticized side flaps and wings with the topsheet partially cut-away.

FIG. 2 shows an alternative sanitary napkin of the present invention.

5 FIG. 3 shows a cross sectional view through a lateral centerline of a sanitary napkin of the present invention.

FIG. 4 shows a partial sectional view through a lateral centerline of another sanitary napkin of the present invention.

10 FIG. 5 shows a partial sectional view through a lateral centerline of still another sanitary napkin of the present invention.

FIG. 6 shows a partial sectional view through a lateral centerline of yet another sanitary napkin of the present invention.

FIG. 7 shows a partial sectional view through a lateral centerline of still yet another sanitary napkin of the present invention.

15 FIG. 8 shows a partial sectional view through a lateral centerline of another sanitary napkin of the present invention.

FIG. 9 shows a partial sectional view through a lateral centerline of yet another sanitary napkin of the present invention.

20 FIG. 10 shows a partial sectional view through a lateral centerline of still yet another sanitary napkin of the present invention.

FIG. 11 shows a partial sectional view through a lateral centerline of an alternative sanitary napkin of the present invention.

25 FIG. 12 shows a sectional view through a lateral centerline of a sanitary napkin of the present invention wherein each wing is individually attached along each side edge of the garment-facing surface of the absorbent article.

FIG. 13 shows a web of material used to form wings for use on a sanitary napkin of the present invention.

30 FIG. 14 shows a partial sectional view through a lateral centerline of still another sanitary napkin of the present invention where the loop member further forms a portion of the wing.

FIG. 15 shows a partial sectional view through a lateral centerline of yet another sanitary napkin of the present invention where both the loop member and the inserted member further form a portion of the wing.

FIG. 16 shows a partial sectional view through a lateral centerline of still another sanitary napkin of the present invention where both the loop member and the backsheet further form a portion of the wing.

FIG. 17 shows a cross sectional view of a sanitary napkin having a folded wing, having a wing adhesive and unitary release member.

FIG. 18 shows a cross sectional view of another sanitary napkin having a folded and tucked wing, having a wing adhesive and unitary release member.

10 DETAILED DESCRIPTION OF THE INVENTION

As shown in FIG. 1, the absorbent article 1 is usually substantially rectangular as a whole, though the end edges can be arc portions 5, respectively. The absorbent member 4 is generally smaller than the backsheet and is substantially rectangular, though both end edges are in the form of an arc portion 6 which pattern after the arc portion 5 of the backsheet 3, and both longitudinal sides 7 of the absorbent pad 4 are curved inward so that the center portion becomes slightly narrow. The wing members 50 extend laterally from each side edge of the article.

FIG. 2 shows an example in which the longitudinal side 7' of an absorbent pad 4 and the heat seal 10' of the elasticized side flap 20 are formed as straight lines.

The absorbent article 1 has two centerlines: a longitudinal centerline and a transverse centerline. The term "longitudinal", as used herein, refers to a line, axis or direction in the plane of the absorbent article 1 that is generally aligned with (e.g., approximately parallel to) a vertical plane which bisects a standing wearer into left and right body halves when the absorbent article 1 is worn. The terms "transverse" or "lateral" as used herein, are interchangeable, and refer to a line, axis or direction which lies within the plane of the absorbent article 1 that is generally perpendicular to the longitudinal direction.

The topsheet is generally registered to cover completely the wearer-facing surface of the absorbent pad. Preferably, the topsheet extends beyond the periphery of the absorbent pad, or wraps around the lateral edges of the absorbent pad, and is secured to the backsheet to enclose the absorbent pad.

One embodiment of an absorbent article 1 according to this invention is shown in FIG. 3. The absorbent article 1 comprises a liquid permeable topsheet 2, a liquid impermeable backsheet 3, and a liquid absorbent pad 4 for absorbing a liquid exuded from the human body positioned there
5 between and having a pair of side edges 7, characterized by comprising:

i) an elasticized side flap 20 along each side edge 7 of said absorbent pad, said side flap 20 comprising:

- a loop member 21 formed from a layer which extends from and loops back toward said side edge 7 of said absorbent pad and is selected
10 from said topsheet 2 and said backsheet 3, said loop member 21 having a base end 22 with an opening 23 proximate said side edge 7 of said absorbent pad, a distal end 24, a garment-facing portion 25, and a wearer-facing portion 26;
- an inserted member 30 formed from a layer which extends from said
15 side edge 7 of said absorbent pad and is selected from said backsheet and the topsheet, said inserted member 30 being inserted through said base end opening 23 into said loop member 21 and having a distal end 31 and a base end 32;
- an elastic material 40 affixed along a portion of the length of said
20 inserted member 30 outboard of said base end 22 of said inserted member 30, wherein said elastic material is not affixed to said loop member 21; and
- a seal 10 attaching said inserted member 30 to said garment-facing
25 portion 25 and wearer-facing portion 26 of said loop member 21 at said base end 22; and

ii) a wing 50 adjacent to and extending laterally from a longitudinal line of juncture 51 located generally along each side edge of said absorbent pad.

30 Elasticized Side Flaps

The elasticized side flap 20 is positioned along at least the central portion of each longitudinal side edge, usually symmetrically positioned about the lateral centerline of the article. The side flap 20 can extend to substantially the entire length of the longitudinal side edge of the article,
35 though typically extends from 25% - 100%, preferably 40% - 60%, the

length of the longitudinal side of the article. The elasticized side flap comprises a loop member, an inserted member, and elastic material, and a seal.

5 a. Loop member

The loop member 21 can be formed from either the topsheet 2 or the backsheet 3. Preferably, the loop member 21 is formed from the topsheet 2 which is more compatible with the skin. When the loop member 21 is formed from the topsheet 2, the backsheet 3 can serve as the inserted member 30. The loop member 21 is formed by extending the layer, in this case the topsheet 2, beyond the edge 7 of the absorbent pad and folding at a distal end 24 inward and back toward the edge of the absorbent core. By "inward" folding is meant folding toward a plane oriented in the x-y direction (or length and width) which passes through the middle of the z-direction (or height) of the absorbent core. When the topsheet (the wearer-facing layer) is the loop member layer, it is folded inward to the garment-facing direction; when the backsheet (the garment-facing layer) is the loop member layer, it is folded inward to the wearer-facing direction. As shown in FIG. 3, when the topsheet 2 forms the loop member 21, it can continue to extend and cover the backsheet-side of the absorbent article. The base end 22 of the loop member is proximate the side edge 7 and has an opening 23 through which the inserted member 30 can be inserted into the inside of the loop member 21. The width of the loop member 21 (from base end 22 to distal end 24) is generally from 10-25 mm, preferably about 15-20 mm. The base end 22 is positioned outboard the edge 7 of the absorbent pad, generally not more than 20 mm, preferably not more than 5 mm. Most preferably, the base end 22 is positioned as close to the absorbent pad edge 7 as possible, along the entire length of the side flap.

30 b. Inserted member

The inserted member 30 is formed by extending the backsheet 3, or the topsheet 2 when the backsheet forms the loop member, beyond the edge 7 of the absorbent pad 4, through the opening 23 and into the loop member 21. The distal end 31 of the inserted member can extend to the distal end 24

of the loop member. It can also be folded or curled over inside the loop member 21. Preferably, the portion of the inserted member 30 extending beyond the base end 22 of the loop member has an effective length of at least 5 mm, more preferably about 10-15 mm. The distal end 31 of the inserted member 30 is intended to be free of and not attached to the loop member 21, at least along the center portion thereof.

Alternatively, the topsheet or the backsheet can also serve as both the loop member and the inserted member. As shown in FIG. 4, the topsheet 2 forms the loop member 21 as herein before described, and is then folded inward again at the fold 55 located at or near the edge 7 of the absorbent pad. The remaining end portion of the topsheet is then inserted into the loop member. In this embodiment, the edge of the backsheet can extend to and be secured by the side seal 10, and can optionally be inserted into the loop member as an inserted member. Conversely, as shown in FIG. 5, the backsheet, though it is not as compatible with the skin of the wearer, can form both the loop member and the inserted member. In such cases, the seal 10 is made between the distal edge 24 and fold 55 of the folded backsheet 3.

20 c. Elastic member

The elastic material 40 provides the elasticity to the elasticized side flap. The elastic material 40 is affixed along at least a portion of the length of the inserted member 30 outboard of the base end 32. Generally, the elastic material 40 is pre-stretched prior to affixing by means 41 (not shown) to the inserted member 30. When the force used to hold the elastic material in the pre-stretched state is released, the elastic material contracts and tends to gather the inserted member. The seal 10 secures the inserted member 30 to the loop member 21 at its base end 32, and generally prevents the elastic material 40 from contracting completely to its fully relaxed position. Preferably, the elastic material 40 is affixed along at least 25% the length of the inserted member 30, more preferably along 40%-60% of the inserted member. The elastic member 40 is not attached to the loop member 21. Any stiffness or wrinkling formed in the inserted member 30 as a result of the contraction of the elastic member 40, or due to the elastic material 40 itself, is separated from the skin of the

wearer by the loop member 21 layer, thus resulting in no reduction in comfort and skin friendliness. Because the elastic material does not come in direct contact with the skin of the wearer, a broad range of materials and elastic conditions can be used. The elastic material 40 can be elastic strings, strands, or films made from materials including: synthetic or natural rubber, such as LYCRA, elastomeric scrim, elastomeric films (including heat shrinkable elastomeric films), elastomeric woven or non-woven webs, elastomeric composites such as elastomeric non-woven laminates, synthetic or natural rubber foams, and the like. A preferred elastic string is a natural rubber commercially available under the designation 9411 produced by Fulflex, Rhode Island. The elastic material can be pre-stretched to any length suitable to gather or contract the side flaps 20 to the desired shape, without causing significant adverse affect on the skin of the wearer. Generally, the elastic material can be pre-stretched from about 5% to 100% (105% to 200% of the original, relaxed length), more preferably from about 10% to about 30%. The elastic material can be affixed to the inserted member using an affixing means 41, such as a mechanical bond or adhesive bond. Mechanical bonds can include pressure or heat bonds that can bond the inserted member to the elastic. More preferably, an adhesive is used. A suitable adhesive is a hot-melt adhesive such as marketed by Findley Adhesives, Inc., Elm Grove, Wisconsin, as Findley Adhesives H2085 or H2119. The inserted member 30 can be folded or curled around the elastic material 40 to improve the attachment. Alternatively, particularly when it is a stretchable film, the elastic material 40 can be wrapped around the distal end 31 of the inserted member 30. The elastic material 40 is preferably affixed at least about 5 mm from the base end 32 of the inserted member, more preferably about 10-15 mm from the base end. Positioning the elastic material 40 attachment away from the base end 32 of the inserted member provides the contracting elastic material with leverage to gather the distal end of the inserted member and to pull upward the ends of the absorbent article to conform the article to the shape of the wearer, and enables the elasticized side flaps to stand upward and press against the thighs of the wearer for better fit and leakage protection.

d. Seal

The seal 10 of the side flap 20 is made along the base end 22 of the loop member 21. The seal 10 can be continuous or intermittent; it can be a straight line or curvilinear. Preferably a curvilinear seal is one curved inward toward the absorbent pad and preferably having a curvature of up to 30 degrees. Preferably the seal (and the base end of the loop member) will conform with the shape of the side edge 7 of the absorbent pad. The length of the seal is generally at least as long as the elastic member; preferably it is longer than the elastic means. In a typical sanitary napkin of the present invention, the seal is from about 50-280 mm, more preferably from about 100-160 mm. in length. The seal serves to anchor the inserted member 30 and allows the elastic member 40 to pull up the longitudinal ends of the absorbent pad. The seal 10 also helps to prevent leakage from the side of the absorbent pad 4. The seal 10 can be a mechanical seal or an adhesive seal. The seal must be sufficient to bond together the garment-facing portion 25 and the wearer-facing portion 26 of the loop member 21 to the inserted member 30 at their respective base ends. The seal 10 can be a mechanical seal or an adhesive seal. Mechanical energy seals are preferred. As used herein, "mechanical energy" includes also thermal energy such as that employed in a heat seal. Such mechanical energy can be applied preferably in the form of an ultrasonic apparatus or pinch roller, which are well known for such purposes. A preferred mechanical seal is a pressure bond seal which bonds together the thermoplastic material of the loop member 21 to the thermoplastic material of the inserted member 30. In one suitable method of sealing the side flap, the assembled article is passed between a rotating anvil roll and a rotating pressure roll which typically exert about 1500-5000 kilograms force per square centimeter pressure on the sealing area, thereby forming a seal having a width generally from 0.5-6 mm, more preferably from 2-4 mm. Preferably, a temperature below about 80 degrees centigrade is used. It is most preferred to operate the anvil and the pressure roll at their ambient temperature. A higher temperature can be used so long as it is well below the thermoplastic melting temperature of the layers, to avoid damaging or weakening these materials at such temperatures. Another preferred method of forming the seal 40 is a heat

seal made by heating the rotating anvil roll and/or the rotating pressure roll at or above the melting temperature of the thermoplastic materials of the elastic panels and chassis, and applying a considerably lower pressure to avoid excessive damage and weakening of the non-woven fabric layers in the area of the attachment lines. The seal can also be made by using an adhesive or chemical seal to bond the materials of the loop member 21 and the inserted member 30 together.

Secondary non-woven sheet

Another preferred sanitary napkin of the present invention is further provided with a secondary non-woven sheet 15 positioned between the topsheet 2 and the absorbent member 4 as a secondary topsheet. The lateral ends of the secondary non-woven sheet can extend beyond the lateral edges 7 of the absorbent pad, and can serve as either the loop member 21 or as an inserted member 30. In this sanitary napkin, the topsheet 2, backsheet 3, or the secondary non-woven sheet 15 can be the loop member 21 layer; or a combination of these layers can be brought together to form the loop member. Preferably a layer not used to form the loop member 21 is used as an inserted member 30. In FIG. 6, the loop member 21 is formed by the topsheet 2 and the inserted member 30 is formed by the secondary non-woven sheet 15 and the backsheet 3. The elastic material 40 is attached to both inserted members. Alternatively, the backsheet 3 only or the secondary non-woven sheet 15 only can be used as the inserted member 30. In FIG. 7 the loop member is formed by the secondary non-woven sheet 15, and the backsheet is extended to form the inserted member 30. The topsheet 2 extends to and is secured along its side edge by the side seal 10. Alternatively as shown in FIG. 8, the side edges of the topsheet can extend beyond the side seal to at least partially cover the wearer-facing portion 26 of loop member 21.

In another embodiment, the loop member can be formed by the backsheet 3, and the secondary non-woven sheet can be extended to form the inserted member. As in the previous embodiments, the topsheet 2 can extend to and be secured along its side edge by the side seal 10, or can be further extended beyond side seal 10 to cover a portion of the wearer-

facing portion 26 of the loop member. The topsheet can instead be inserted into the loop member as a second inserted member.

In another sanitary napkin of the present invention shown in FIG. 9, the
5 absorbent article 1 has a topsheet 2 having a central portion and a side
portion on each lateral side of the central portion, and a non-woven outer
sheet 11 positioned on the wearer-facing surface along each side portion
of said topsheet. The non-woven outer sheet 11 can be bonded (not
10 shown), preferably with a mechanical seal (pressure or heat seal),
continuously or in discrete areas, to the topsheet layer to secure its edges
from rolling and tearing. The non-woven outer sheet 11 is preferably a
soft, comfortable, skin-friendly non-woven fabric, which preferably forms
the loop member 21 of the side flap. In this sanitary napkin, the topsheet
2, backsheet 3, or the non-woven outer sheet 11, or a combination of
15 these, can form the loop member 21 layer. As shown in FIG. 9, the non-
woven outer sheet 11 also loops back under the topsheet 2 to form the
secondary non-woven sheet 15. The topsheet 2 forms the inserted
member 30. The backsheet extends beyond the edge of the absorbent
pad and is secured to the garment-facing surface 25 of the loop member
20 by seal 10.

In another preferred sanitary napkin shown in FIG. 10, the non-woven
outer sheet 11 forms the loop member 21 and then can extend to cover a
portion of the garment-facing surface of the backsheet 3. The backsheet 3
and the topsheet 2 form the inserted members 30; alternatively, the
25 backsheet 3 and the topsheet 2 alone can form inserted member 30.

FIG. 11 shows another sanitary napkin of the present invention where
the inserted member 30 is a separate, distinct layer from any topsheet,
backsheets, or other layer that can extend from the side edge 7 of the
absorbent pad. In this embodiment, the elastic member 40 can be made
30 integral with the inserted member 30, preferably with the elastic member
positioned outboard of the base end 32 of the inserted member.

The use of the non-woven outer sheet 11 or the secondary non-woven
sheet 15 to form the loop member reduces the amount of topsheet, which
is typically a more expensive component, and hence reduces the

production cost. Another benefit of the non-woven sheets is an improvement in comfort and skin friendliness.

The secondary non-woven sheet 15 and the non-woven outer sheet 11 preferably comprise a non-woven fabric web for comfort and improved skin-feel. Non-woven webs can be made from natural fibers (e.g., wood or cotton fibers), synthetic fibers (e.g., polyester or polypropylene fibers), or a combination of natural and synthetic fibers. Preferably, the non-woven fabric is made of a hydrophilic or a surfactant-treated hydrophobic material. A preferred non-woven fabric is an air-through non woven supplied by Fukumura Seishi Kabushiki Kaisha. This non-woven comprises: a first layer which comprises about 50% w/w polyethylene (PE) and about 50% w/w polypropylene (PP) fibers having a denier of about 2, the fibers having a core made of polypropylene and a outer sheath surrounding the core made of polyethylene; and a second layer which comprises 50% w/w polyethylene (PE) and about 50% w/w polyester (PET) fibers having a denier of about 2, the fibers having a core made of polyester and a outer sheath surrounding the core made of polyethylene. The above fibers used in the first and second layers are known in the art as a "bi-component fiber". The sheet can be oriented with either layer facing the wearer.

Wings

The wings 50 are configured to extend from the side edges of the sanitary napkin and to drape over the edges of the wearer's panties in the crotch region so that the wings 50 are disposed between the edges of the wearer's panties and the wearer's thighs. The wings 50 serve at least two purposes. First, the wings help to prevent soiling of the wearer's body and panty by menstrual fluid, preferably by forming a double wall barrier along the edges of the panty. In combination with the elasticized side flap, which also forms a barrier between the absorbent pad and the skin and panty of the wearer, the sanitary napkin of the present invention provides excellent protection against soiling of the wearer's body and panty. Second, the wings are preferably provided with attachment means 60 on their garment surface, as shown in FIG. 4, so that the wings can be folded back under the panty and attached to the garment facing side of the panty.

The wings 50 can be constructed of various materials including materials similar to the topsheet 2, backsheet 3, or a laminate of these materials. Further, the wings can be a separate element attached to the main body of the napkin, or can comprise extensions of the topsheet 2 and backsheet 3 (i.e., unitary). A number of sanitary napkins having wings suitable or adaptable for use with the sanitary napkins of the present invention are disclosed in U.S. 4,687,478 entitled "Shaped Sanitary Napkin With Flaps", which issued to Van Tilburg on August 18, 1987; U.S. 4,589,876 entitled "Sanitary Napkin", which issued to Van Tilburg on May 20, 1986; and U.S. 4,608,047, entitled "Sanitary Napkin Attachment Means", which issued to Mattingly on August 26, 1986. Each of these patents are incorporated herein by reference.

It is most preferred that the attachment of the wing occur along line of juncture 51 which is inboard of (closer to the longitudinal centerline than) side seal 10. This enables the wing 50 and the side flap 20 to function independently.

The wing 50 can comprise one or more discrete fabric layers fastened or laminated together, for example by adhesive or mechanical bonding. For skin compatibility reasons, it is preferred that the wing comprise a non-woven or other material suitable for use as a topsheet on that surface which faces or contacts the skin of the wearer.

In another embodiment of the present invention, shown in FIG. 12, each wing 50 is a separate member attached on the garment-facing side of the napkin. The wings 50 are preferably cut from a single web of material prior to attachment to the main body portion 8. As shown in FIG. 13, the web of material 100 need only be as wide as the lateral width of one flap (or only slightly wider than the width of a flap). The edges of the web of material oriented in the machine direction can be trimmed to the desired curvature for the proximal edges of the flaps. After the edges are trimmed, the edges 55 of the flaps can be formed by cutting the web along a sinusoidal path. The sinusoidal cutting path can have an amplitude that extends from one edge of the web to the other. The sinusoidal cutting path forms flap pieces which are "nested" with each other. The cutting path can, thus, simultaneously form the edges of two different flaps.

Alternatively, as shown in FIG. 3, the two wings can be combined into a single, integral wing member 53 which is attached to the garment-facing surface of the absorbent article using a mechanical or adhesive bonding as described herein before. The panty fastening adhesive 13 and release liner 14 are then affixed to the single wing member 53.

The wings 50 have attachment means 60 for attachment of the distal end of each wing directly to the garment-facing surface of the wearer's panties or undergarment. Typically, attachment means 60 comprises a panty adhesive 61 and a release film 62 comprising materials as described herein before. In this way, the wings serve to keep the sanitary napkin properly positioned in the panty.

Another preferred embodiment is a sanitary napkin wherein a fabric layer used to form a portion of the elasticized side flap 20 is extended to also form a portion of the wing 50. The loop member 21 and the inserted member 30 can continue to the garment-facing surface of the article to form wing 50. Since the topsheet, backsheet, secondary non-woven sheet and non-woven outer sheet can form individually or in combination, either the loop member 21 or the inserted member 30, there are numerous possible embodiments of this sanitary napkin.

In FIG. 14, topsheet 2 extends beyond the edge of the absorbent pad to form the loop member 21. A secondary non-woven sheet 15 and the backsheet 3 form inserted members 30. The garment-facing portion 25 of the loop member extends beyond seal 10 and then folds outward again at fold 63 to form a folded portion 64. The layers of the folded portion 64 outboard of fold 63 are attached together with seal 65 using a mechanical or adhesive bond or other securing means, forming line of juncture 51. Preferably the line of juncture 51 is formed inboard of side seal 10. The folded portion 64 extends beyond the line of juncture 51 to form the wing portion 50a of the wing 50. A second wing material 53 is laminated to the topsheet-formed wing portion 50a and to the garment-facing portion of the absorbent article, and forms wing portion 50b.

In FIG. 15, secondary non-woven layer 15 forms loop member 21. The garment-facing portion 25 of loop member 21 then extends back beyond seal 10. Backsheet 3 extends beyond the edge of the absorbent pad and folds outwardly to form an inserted member loop 30'. The distal end of the

inserted member loop 30' is inserted into loop member 21, and elastic 40 is attached to the inserted member loop 30'. The garment-facing portion of the inserted member loop 30' extends beyond seal 10. The garment-facing portions of the inserted member loop 30' and the loop member 21 then fold outward again at fold 63 to form a folded portion 64. Seal 65 secures the layers of the folded portion 64 outboard of fold 63, forming the line of juncture 51. The folded portion 64 extends beyond the line of juncture 51 to form wing 50.

Yet another preferred sanitary napkin is shown in FIG. 16. Non-woven outer sheet 11 forms loop member 21. The garment-facing surface of loop member 21 then extends beyond seal 10. Secondary non-woven layer 15 forms inserted member 30. Topsheet 2 is inserted partially into and is secured along its longitudinal edge by seal 10. Backsheet 3 extends beyond the edge of the absorbent pad and folds outwardly, at or just beyond side seal 10, back toward the center of the article. The extended backsheet layer and the garment-facing portion of the loop member 21 then fold outward again at fold 63 to form a folded portion 64. Seal 65 secures the layers of the folded portion 64 outboard of fold 63, forming the line of juncture 51. The folded portion 64 extends beyond the line of juncture 51 to form wing 50.

The wing 50 of the sanitary napkin can have zones of differential extensibility (not shown) for relieving the stresses that develop in the wings when the wings are folded down along the edges of the wearer's panties in the crotch. The wings are divided into a front half and a back half by a wing transverse centerline. The absorbent article has two corner regions (not shown) located adjacent the area of the ends of the junctures 51. One corner region is located adjacent the area of the juncture in each direction remote from the principal transverse centerline. The sanitary napkin comprises zones of differential extensibility which allow the corner regions to extend transversely outward to a greater degree than the portions of the sanitary napkin located along the wing transverse centerline. The zones of differential extensibility provide a means for the relief of stresses in the wings of the sanitary napkin when the sanitary napkin is placed in the wearer's undergarments. The zone of differential extensibility can be provided by a number of means, including stretching of

the material, by pleating or folding of the fabric, or joining the wing to the article along a curved juncture. Preferably the line of juncture is curved inward toward the principle longitudinal centerline, whereby excess flap material is present in the corner regions when the wings is folded outward.

5 Sanitary napkins comprising such zones of differential extensibility are disclosed in U.S. Patent Application 07/769891, Lavash et al., entitled "Absorbent Article Having Flaps and Zones of Differential Extensibility", filed October 1, 1991, incorporated herein by reference.

In a preferred sanitary napkin, the wings are folded and have a unitary
10 release material joined to a portion of the absorbent article such that the wing adhesive of at least one of the wing is superposed by the unitary release material when the wing is folded along a fold line 56 of the wing. The unitary release material can be joined to a portion of the wing or can be joined to any other portion of the absorbent napkin, such as the main
15 body. Such folded wings are disclosed in commonly-assigned U.S. patent applications No. 906,593, filed June 30, 1992, "Absorbent Article Having Unitary Release Material", in the name of Lavash et. al, and No.906,629, filed June 30, 1992, "Absorbent Article Having Tucked Flaps", in the name of Osborn, III, et. al., which are hereby incorporated by reference. In a
20 preferred embodiment shown in FIG. 17, each wing comprises a proximal edge 57 adjacent the line of juncture, a distal edge 58 disposed away from the line of juncture, a fold line 56 intermediate the proximal and distal edges, a wing adhesive 61' joined thereto, and a unitary release member 62' joined thereto, such that the unitary release material 62' superposes
25 the wing adhesive and is removably secured thereto, when the wing is folded along the fold line 56. In yet another preferred embodiment, the sanitary napkin has a recessed area 80 on the garment-facing face of the napkin, bounded by the garment-facing portion between the lateral side of the napkin and the line of juncture 51, and by the wearer-facing side of the
30 wing 50. The wing is folded and tucked into the recess area 80, as shown in FIG. 18. Preferably a portion of the distal edge of the wing extends from the recess area to provide a grasp tab member 59.

Absorbent pad

The absorbent pad 4 is any absorbent means which is capable of absorbing or retaining liquids (e.g., menses and/or urine). As discussed above, the absorbent core 4 can be manufactured in a wide variety of sizes and shapes (e.g., rectangular, oval, hourglass, dog bone, asymmetric, etc.) and from a wide variety of liquid-absorbent materials commonly used in absorbent napkins and other absorbent articles such as comminuted wood pulp which is generally referred to as airfelt. Examples of other suitable absorbent materials include creped cellulose wadding; meltblown polymers including coform; chemically stiffened, modified or cross-linked cellulosic fibers; synthetic fibers such as crimped polyester fibers; peat moss; tissue including tissue wraps and tissue laminates; absorbent foams; absorbent sponges; superabsorbent polymers; absorbent gelling materials; or any equivalent material or combinations of materials, or mixtures of these. The configuration and construction of the absorbent core can also be varied (e.g., the absorbent core can have varying caliper zones (e.g., profiled so as to be thicker in the center), hydrophilic gradients, superabsorbent gradients, or lower density and lower average basis weight acquisition zones; or can comprise one or more layers or structures). The total absorbent capacity of the absorbent core should, however, be compatible with the design loading and the intended use of the absorbent article. Further, the size and absorbent capacity of the absorbent core can be varied to accommodate different uses such as incontinence pads, pantliners, regular sanitary napkins, or overnight sanitary napkins.

Exemplary absorbent structures for use as the absorbent core of the present invention are described in U.S. Patent 4,950,264 entitled "Thin, Flexible Sanitary Napkin" issued to Osborn on August 21, 1990; U.S. Patent 4,610,678 entitled "High-Density Absorbent Structures" issued to Weisman et al. on September 9, 1986; U.S. Patent 4,834,735 entitled "High Density Absorbent Members Having Lower Density and Lower Basis Weight Acquisition Zones", issued to Alemany et al. on May 30, 1989; and European Patent Application No. 0 198 683, The Procter & Gamble Company, published October 22, 1986 in the name of Duenk, et al. Each of these patents are incorporated herein by reference.

A preferred absorbent structure includes a fluid-stable, aggregate macrostructures of interconnected absorbent particles using a crosslinking agent, preferably a cationic amino-epichlorohydrin adduct that: (1) reacts rapidly with the carboxy groups of the polymer present in the absorbent particles and primarily at the surface thereof to minimize absorbency effects; (2) provides improved absorbency and mechanical properties for the aggregate macrostructures; (3) provides flexible sheets of such aggregate macrostructures that can be easily made into absorbent structures used in diapers, adult incontinence pads, sanitary napkins and the like; and (4) does not necessarily require organic solvents such as isopropanol. Such structures can also comprise a non-continuous absorbent macrostructure having voids to permit the macrostructure to expand into the void when it absorbs aqueous liquids and swells. Such absorbent structures are disclosed and claimed in co-pending, commonly assigned U.S. patent applications Serial No. 955,635, in the name of Ebrahim Rezai et al, entitled "Porous, Absorbent Macrostructures of Bonded Absorbent Particles Surface Crosslinked With Cationic Amino-Epichlorohydrin Adducts", Attorney Docket No. 4731, filed October 2, 1992; No. 955,638, in the name of Michael S. Kolodesh et al, entitled "Method and Apparatus for Making Cohesive Sheets from Particulate Absorbent Polymeric Composition," filed October 2, 1992; No. 08/142258, in the name of Kesyin Hsueh et al, entitled "Absorbent Composites Comprising a Porous Macrostructure of Absorbent Gelling Particles and a Substrate", Attorney Docket No. JA-66U, filed October 22, 1993; No. 08/142259, in the name of Ebrahim Rezai et al, entitled "Non-Continuous Absorbent Composites Comprising a Porous Macrostructure of Absorbent Gelling Particles and a Substrate", Attorney Docket No. JA-67U, filed October 22, 1993; No. 08/142629, in the name of Albert C. Dierckes, Jr. et al, entitled "Non-Continuous Absorbent Cores Comprising a Porous Macrostructure of Absorbent Gelling Particles", Attorney Docket No. JA-68U, filed October 22, 1993, said applications being incorporated herein by reference.

In a preferred sanitary napkin of the present invention, an acquisition layer(s) can be positioned between the topsheet and the absorbent core. The acquisition layer can serve several functions including improving

wicking of exudates over and into the absorbent core. There are several reasons why the improved wicking of exudates is important, including providing a more even distribution of the exudates throughout the absorbent core and allowing the sanitary napkin 1 to be made relatively thin. The wicking referred to herein can encompass the transportation of liquids in one, two or all directions (i.e, in the x-y plane and/or in the z-direction). The acquisition layer can be comprised of several different materials including non-woven or woven webs of synthetic fibers including polyester, polypropylene, or polyethylene; natural fibers including cotton or cellulose; blends of such fibers; or any equivalent materials or combinations of materials. Examples of sanitary napkins having an acquisition layer and a topsheet are more fully described in U.S. 4,950,264 issued to Osborn and U.S. Patent Application Serial No. 07/810,774, "Absorbent Article Having Fused Layers", filed December 17, 1991 in the names of Cree, et al. Each of these references are incorporated herein by reference. In a preferred embodiment, the acquisition layer can be joined with the topsheet by any of the conventional means for joining webs together, most preferably by fusion bonds as is more fully described in the above-referenced Cree application.

In another preferred sanitary napkin of the present invention, a wicking or fluid distribution strip (not shown) can be positioned between the topsheet and the absorbent core. The wicking strip provides permeability and diffusivity of the bodily liquids into and along the longitudinal length of the absorbent core. Preferred wicking strips are melt-blown or spun-bond non-wovens, and provide enhanced fluid distribution in the longitudinal direction of the absorbent article. A particularly preferred wicking strip comprises a series of longitudinally-oriented embossments or compressments, or both, in the non-woven wicking strip, as described in co-pending Japanese Patent Application No. 294665/1991, filed November 11, 1991 (Procter & Gamble Far East Inc.).

The longitudinal end edge portion 5 of the absorbent article 1 is typically formed by joining together the topsheet 2 and the backsheet 3, as well as any additional non-woven fabric layer 15, with a suitable seal 8, preferably a heat seal.

The backsheet 3 and topsheet 2, and any additional non-woven fabric layer 15 as applicable, can be secured to the absorbent core 4 by attachment means (not shown) such as those well known in the art. For example, the backsheet 3 and/or the topsheet 2 can be attached to each other by a uniform continuous layer of adhesive, a patterned layer of adhesive, or an array of separate lines, spirals, or spots of adhesive. Adhesives which have been found to be satisfactory are manufactured by H. B. Fuller Company of St. Paul, Minnesota under the designation HL-1258 or H-2031. The attachment means will preferably comprise an open pattern network of filaments of adhesive as is disclosed in U.S. Patent 4,573,986 entitled "Disposable Waste-Containment Garment", which issued to Minetola, et al. on March 4, 1986, and which is incorporated herein by reference. An exemplary attachment means of an open pattern network of filaments comprises several lines of adhesive filaments swirled into a spiral pattern such as illustrated by the apparatus and method shown in U.S. Patent 3,911,173 issued to Sprague, Jr. on October 7, 1975; U.S. Patent 4,785,996 issued to Zieker, et al. on November 22, 1978; and U.S. Patent 4,842,666 issued to Werenicz on June 27, 1989. Each of these patents are incorporated herein by reference. Alternatively, the attachment means can comprise heat bonds, pressure bonds, ultrasonic bonds, dynamic mechanical bonds, or any other suitable attachment means or combinations of these attachment means as are known in the art.

Topsheet

The topsheet 2 is compliant, soft feeling, and non-irritating to the wearer's skin. Further, the topsheet 2 is liquid pervious permitting liquids (e.g., menses and/or urine) to readily penetrate through its thickness. A suitable topsheet 2 can be manufactured from a wide range of materials such as woven and non-woven materials; polymeric materials such as apertured formed thermoplastic films, apertured plastic films, and hydroformed thermoplastic films; porous foams; reticulated foams; reticulated thermoplastic films; and thermoplastic scrims. Suitable woven and non-woven materials can be comprised of natural fibers (e.g., wood or cotton fibers), synthetic fibers (e.g., polymeric fibers such as polyester,

polypropylene, or polyethylene fibers) or from a combination of natural and synthetic fibers. A preferred topsheet comprises an apertured formed film. Apertured formed films are preferred for the topsheet because they are pervious to body exudates and yet non-absorbent and have a reduced tendency to allow liquids to pass back through and re-wet the wearer's skin. Thus, the surface of the formed film which is in contact with the body remains dry, thereby reducing body soiling and creating a more comfortable feel for the wearer. Suitable formed films are described in U.S. Patent 3,929,135, entitled "Absorptive Structures Having Tapered Capillaries", which issued to Thompson on December 30, 1975; U.S. Patent 4,324,246 entitled "Disposable Absorbent Article Having A Stain Resistant Topsheet", which issued to Mullane, et al. on April 13, 1982; U.S. Patent 4,342,314 entitled "Resilient Plastic Web Exhibiting Fiber-Like Properties", which issued to Radel. et al. on August 3, 1982; U.S. Patent 4,463,045 entitled "Macroscopically Expanded Three-Dimensional Plastic Web Exhibiting Non-Glossy Visible Surface and Cloth-Like Tactile Impression", which issued to Ahr et al. on July 31, 1984; and U.S. 5,006,394 "Multilayer Polymeric Film" issued to Baird on April 9, 1991. Each of these patents are incorporated herein by reference. The preferred topsheet for the present invention is the formed film described in one or more of the above patents and marketed on sanitary napkins by The Procter & Gamble Company of Cincinnati, Ohio as "DRI-WEAVE".

In a preferred embodiment of the present invention, the body surface of the formed film topsheet is hydrophilic so as to help liquid to transfer through the topsheet faster than if the body surface was not hydrophilic so as to diminish the likelihood that menstrual fluid will flow off the topsheet rather than flowing into and being absorbed by the absorbent core. In a preferred embodiment, surfactant is incorporated into the polymeric materials of the formed film topsheet such as is described in U.S. Patent Application Serial No. 07/794,745, "Absorbent Article Having A Nonwoven and Apertured Film Coversheet" filed on November 19, 1991 by Aziz, et al., which is incorporated herein by reference. Alternatively, the body surface of the topsheet can be made hydrophilic by treating it with a surfactant such as is described in the above referenced U.S. 4,950,254 issued to Osborn, incorporated herein by reference.

Backsheet

The backsheet 3 is impervious to liquids (e.g., menses and/or urine) and is preferably manufactured from a thin plastic film, although other flexible liquid impervious materials can also be used. As used herein, the term "flexible" refers to materials which are compliant and will readily conform to the general shape and contours of the human body. The backsheet 3 prevents the exudates absorbed and contained in the absorbent core 4 from wetting articles which contact the sanitary napkin such as pants, pajamas and undergarments. The backsheet 3 can thus comprise a woven or non-woven material, polymeric films such as thermoplastic films of polyethylene or polypropylene, or composite materials such as a film-coated non-woven material. Preferably, the backsheet is a polyethylene film having a thickness of from about 0.012 mm (0.5 mil) to about 0.051 mm (2.0 mils). Exemplary polyethylene films are manufactured by Clopay Corporation of Cincinnati, Ohio, under the designation P18-0401 and by Ethyl Corporation, Visqueen Division, of Terre Haute, Indiana, under the designation XP-39385. The backsheet is preferably embossed and/or matte finished to provide a more cloth-like appearance. Further, the backsheet 3 can permit vapors to escape from the absorbent core 4 (i.e., breathable) while still preventing exudates from passing through the backsheet 3.

In use, the sanitary napkin 1 can be held in place by any support means or attachment means well-known for such purposes. Preferably, the sanitary napkin is placed in the user's undergarment or panty and secured thereto by a fastener such as an adhesive 13. The adhesive 13 provides a means for securing the sanitary napkin in the crotch portion of the panty. Thus, a portion or all of the garment-facing surface of the absorbent article 1 is coated with adhesive. Any adhesive or glue used in the art for such purposes can be used for the adhesive herein, with pressure-sensitive adhesives being preferred. Suitable adhesives are Century A-305-IV manufactured by the Century Adhesives Corporation of Columbus, Ohio; and Instant Lock 34-2823 manufactured by the National Starch and Chemical Company of Bridgewater, NJ. Suitable adhesive fasteners are also described in U.S. Patent 4,917,697. Before the sanitary

napkin is placed in use, the pressure-sensitive adhesive is typically covered with a removable release liner 14 in order to keep the adhesive from drying out or adhering to a surface other than the crotch portion of the panty prior to use. Suitable release liners are also described in the
5 above-referenced U.S. Patent 4,917,697. Any commercially available release liners commonly used for such purposes can be utilized herein. Non-limiting examples of suitable release liners are BL30MG-A Silox E1/O and BL30MG-A Silox 4P/O both of which are manufactured by the Akrosil Corporation of Menasha, WI. The sanitary napkin 1 of the present
10 invention is used by removing the release liner and thereafter placing the sanitary napkin in a panty so that the adhesive contacts the panty. The adhesive 13 assists in maintaining the sanitary napkin in its position within the panty during use.

15 As clearly seen from the above illustration, according to this invention, a sanitary napkin is provided comprising a loop member which stands up and helps the article to form a curved shape, and a wing member to improve securement and provide an additional layer of material between the source of menses flow and the wearer's garments, thereby improving
20 fit, comfort, and reducing the risk of side leakage. The elastic material is attached to the inserted member but is not attached directly to the loop member. Any stiffness or wrinkling formed in the inserted member as a result of the contraction of the elastic member, or due to the elastic member itself, is separated from the skin of the wearer by the loop
25 member layer, thus resulting in no reduction in comfort and skin friendliness. Because the elastic material does not come in direct contact with the skin of the wearer, a broad range of materials and elastic conditions can be used.

While particular embodiments of the present invention have been
30 illustrated and described, it would be obvious to those skilled in the art that various other changes and modifications can be made without departing from the spirit and scope of the invention. Therefore the appended claims are intended to cover all such changes and modifications that are within the scope of this invention.

What is claimed is:

1. An absorbent article comprising a liquid permeable topsheet, a liquid impermeable backsheet, and a liquid absorbent pad for absorbing a liquid exuded from the human body positioned there between and having a pair of side edges, comprising

i) an elasticized side flap along each side edge of said absorbent pad, said side flap comprising:

- a loop member which extends from and loops back toward said side edge of said absorbent pad, said loop member having a base end with an opening proximate said side edge of said absorbent pad, a distal end, a garment-facing portion, and a wearer-facing portion;
- an inserted member extending through said base end opening into said loop member and having a distal end and a base end adjacent said base end opening;
- an elastic material affixed along a portion of the length of said inserted member outboard of said base end of said inserted member, wherein said elastic material is not affixed to said loop member; and
- a seal attaching said inserted member to said garment-facing portion and wearer-facing portion of said loop member at said base end; and

ii) a wing adjacent to and extending laterally from a line of juncture located generally along each side edge of said absorbent pad.

2. An absorbent article according to Claim 1 wherein said loop member is formed from a layer which extends from and loops back toward said side edge of said absorbent pad and is selected from said topsheet and said backsheet, and said inserted member is formed from a layer which extends from said side edge of said absorbent pad, and is selected from said backsheet and the topsheet.

3. An absorbent article comprising a liquid permeable topsheet, a liquid impermeable backsheet, a liquid absorbent pad for absorbing a liquid exuded from the human body positioned there between and having a pair of side edges, and a secondary non-woven sheet positioned between said topsheet and said absorbent pad, comprising

i) an elasticized side flap along each side edge of said absorbent pad, said side flap comprising:

- a loop member formed from a layer which extends from and loops back toward said side edge of said absorbent pad and is selected from said topsheet, said backsheet, said secondary non-woven sheet, and a combination thereof, said loop member having a base end with an opening proximate said side edge of said absorbent pad, a distal end, a garment-facing portion, and a wearer-facing portion;
 - an inserted member formed from a layer which extends from said side edge of said absorbent pad, and is selected from said backsheet, said topsheet, said secondary non-woven sheet, and combination thereof, said inserted member being inserted through said base end opening into said loop member and having a distal end and a base end adjacent said base end opening;
 - an elastic material affixed along a portion of the length of said inserted member outboard of said base end of said inserted member, wherein said elastic material is not affixed to said loop member; and
 - a seal attaching said inserted member to said garment-facing portion and wearer-facing portion of said loop member at said base end; and
- ii) a wing adjacent to and extending laterally from a line of juncture located generally along each side edge of said absorbent pad.

4. An absorbent article comprising, in order, a liquid impermeable backsheet, a liquid absorbent pad for absorbing a liquid exuded from the human body and having a pair of side edges, a liquid permeable topsheet having a central portion and a side portion on each lateral side of the central portion, and a non-woven outer sheet positioned along each side portion of said topsheet, comprising an elasticized side flap along each side edge of said absorbent pad, said side flap comprising:

- a loop member formed from a layer which extends from and loops back toward said side edge of said absorbent pad and is selected from said topsheet, said backsheet, said non-woven outer sheet, and combination thereof, said loop member having a base end with an opening proximate said side edge of said absorbent pad, a distal end, a garment-facing portion, and a wearer-facing portion;
- an at least one inserted member formed from a layer which extends from said side edge of said absorbent pad, and is selected from said backsheet, said topsheet, said non-woven outer sheet, and combination thereof, said inserted member being inserted through said base end opening into said loop member and having a distal end and a base end adjacent said base end opening;

- an elastic material affixed along a portion of the length of said inserted member outboard of said base end of said inserted member, wherein said elastic material is not affixed to said loop member; and
- a seal attaching said inserted member to said garment-facing portion and wearer-facing portion of said loop member at said base end; and
- ii) a wing adjacent to and extending laterally from a line of juncture located generally along each side edge of said absorbent pad.

5. An absorbent article according to Claim 2 or 3 wherein said loop member is the topsheet and said at least one inserted layer is said backsheet.

6. An absorbent article according to Claim 3 wherein said loop member is said secondary non-woven sheet and said at least one inserted layer comprises said backsheet.

7. An absorbent article according to Claim 4 wherein said loop member is said non-woven outer sheet and said at least one inserted layer comprises said backsheet.

8. An absorbent article according to Claim 1, 2, 3 or 4 wherein each said wing comprises zones of differential extensibility for relieving the stresses that develop in the wings when the wings are folded down along the edges of a wearer's panties in the crotch.

9. An absorbent article according to Claim 1, 2, 3 or 4 wherein said loop member further forms a portion of said wing.

10. An absorbent article according to Claim 1, 2, 3 or 4 wherein said inserted member further forms a portion of said wing.

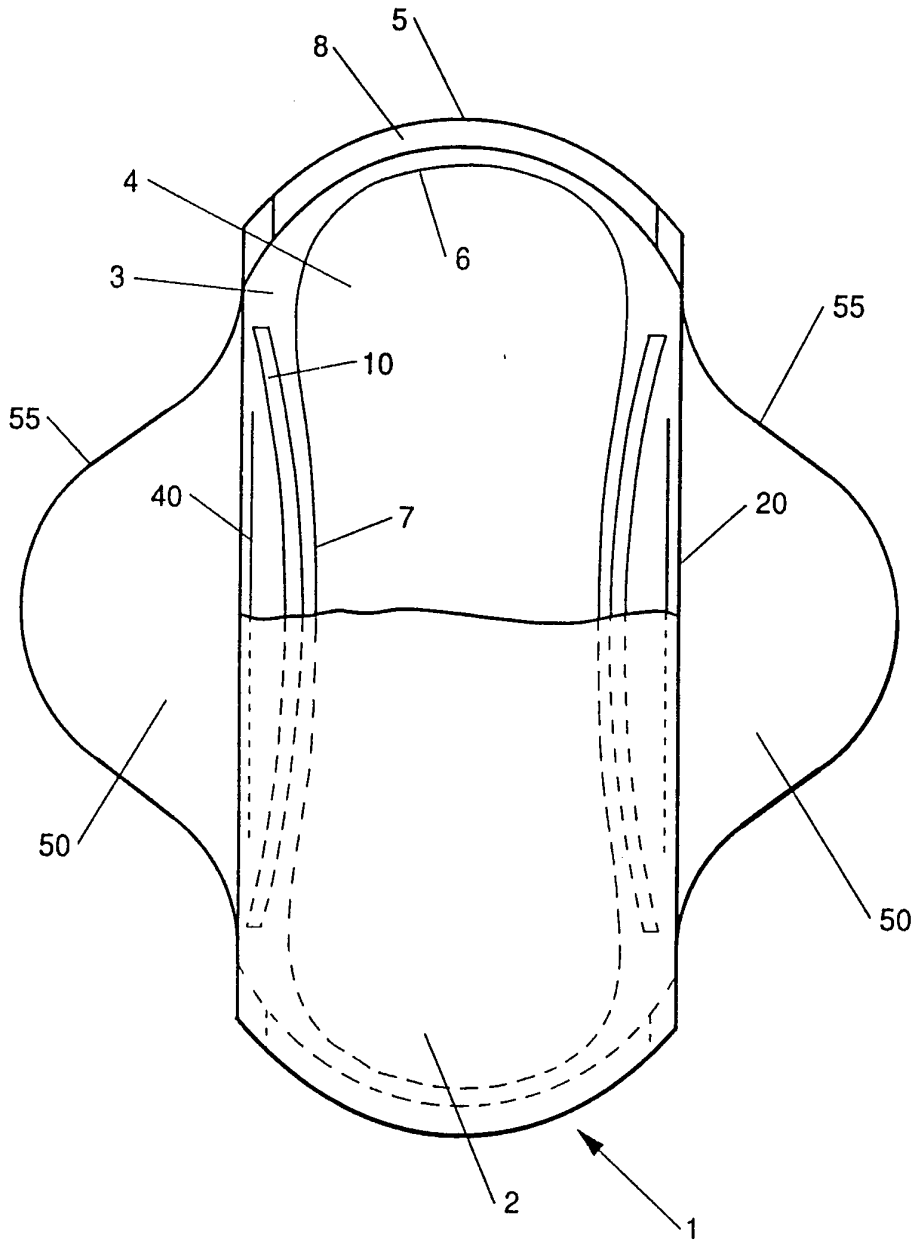

Fig. 1

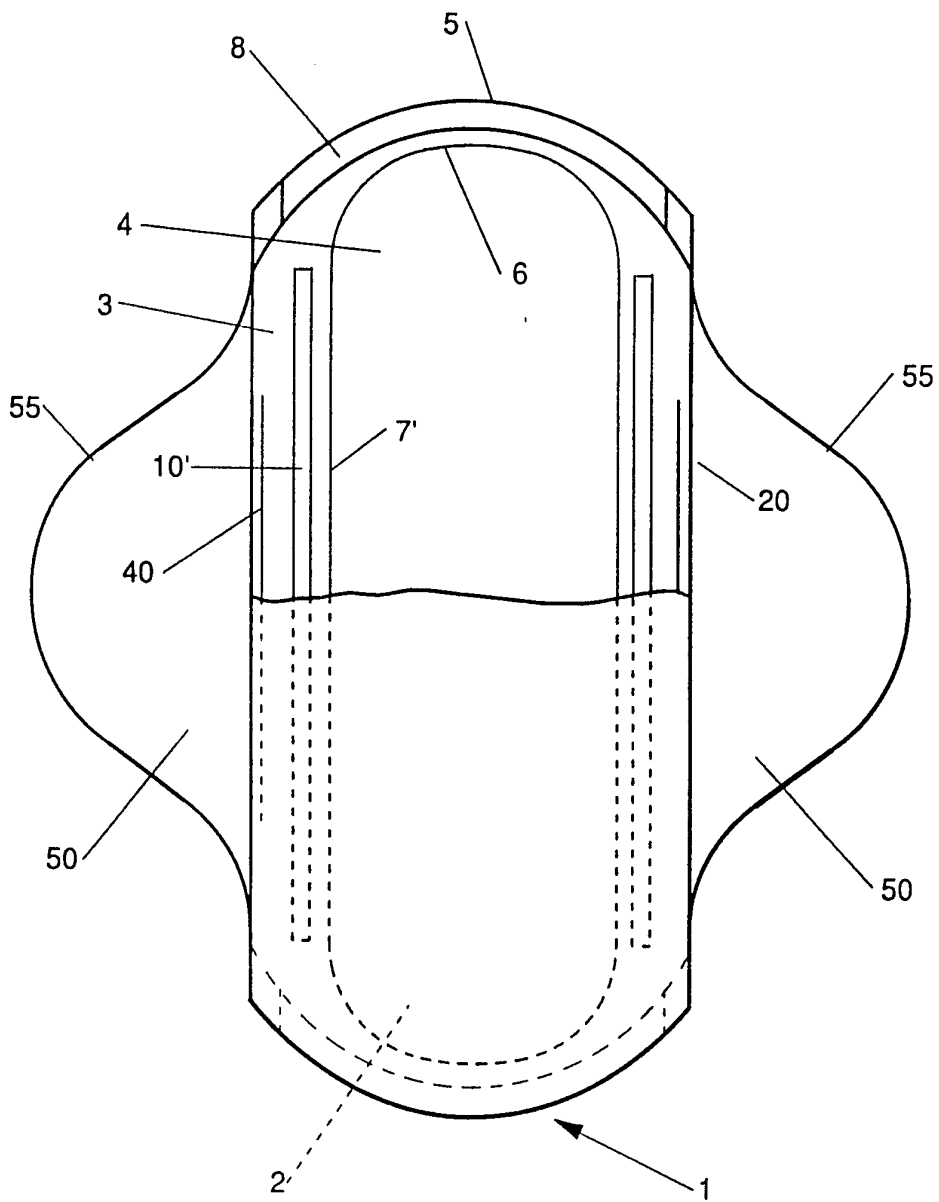

Fig. 2

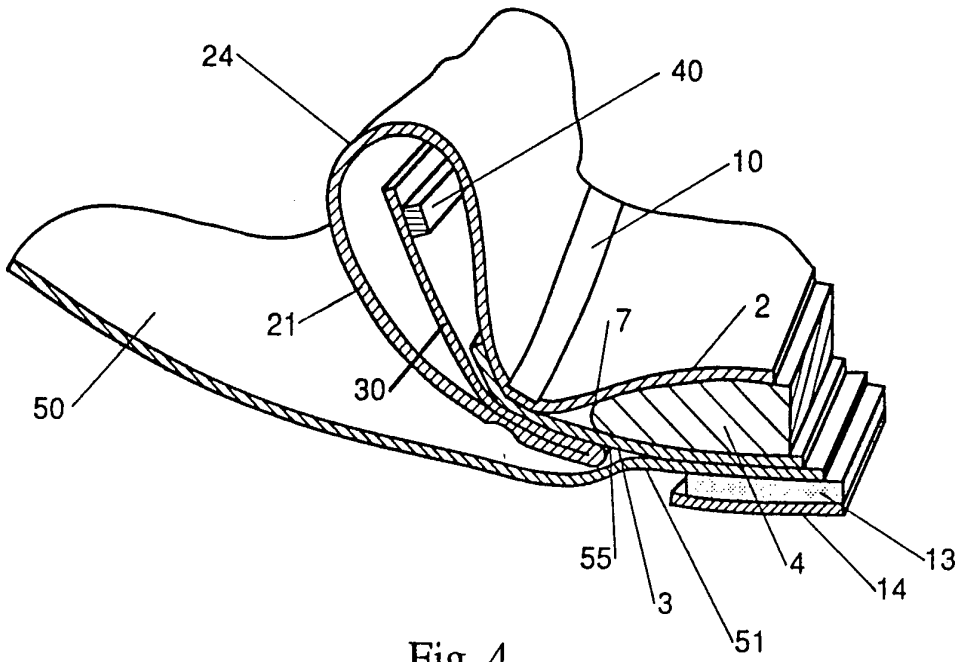

Fig. 4

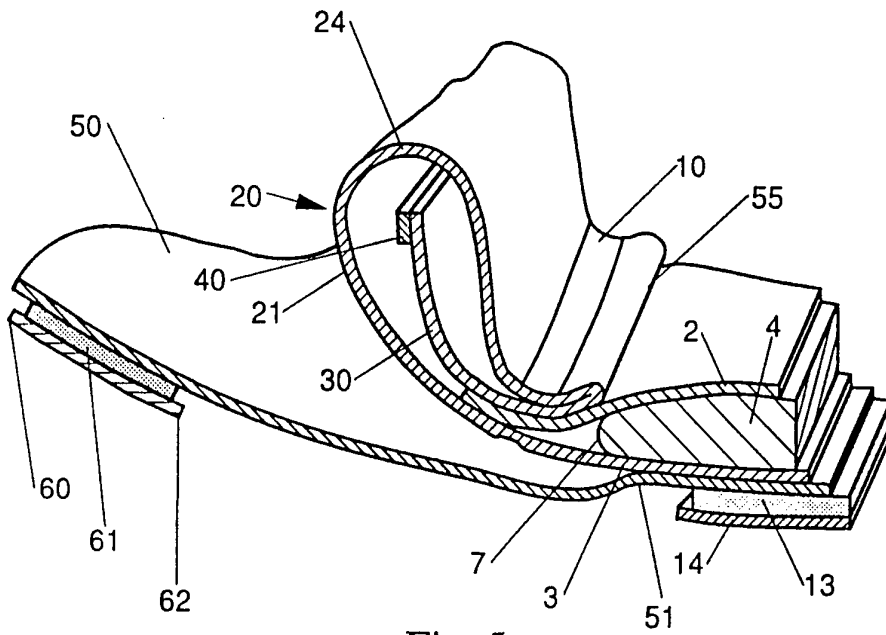

Fig. 5

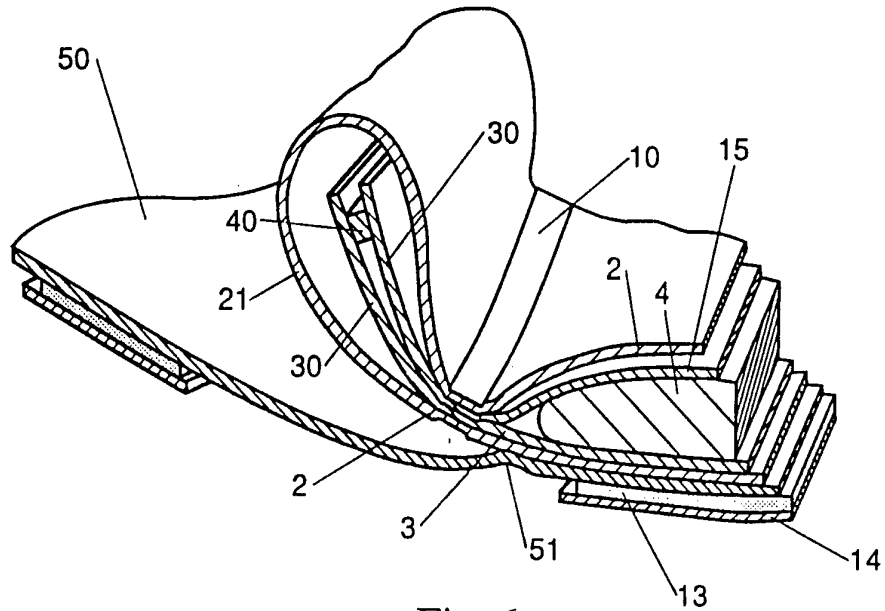

Fig. 6

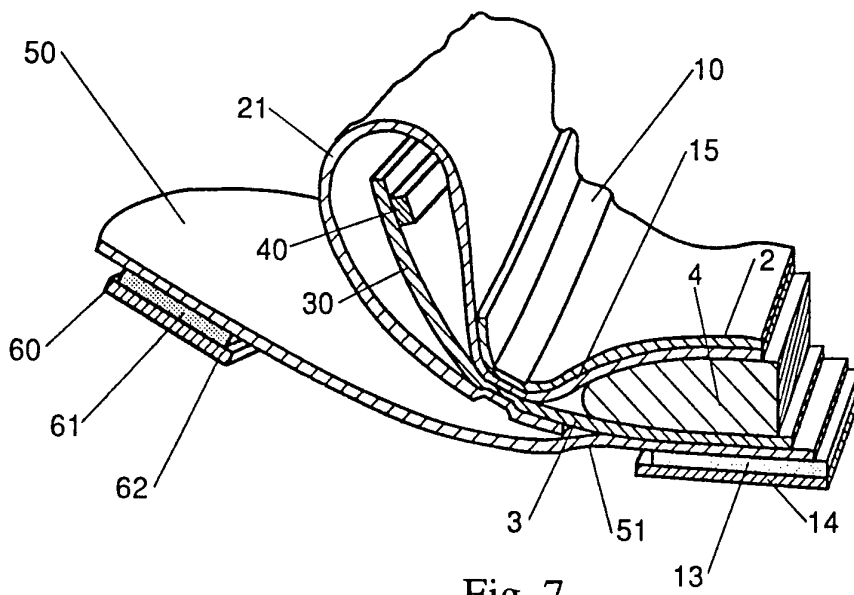

Fig. 7

6/13

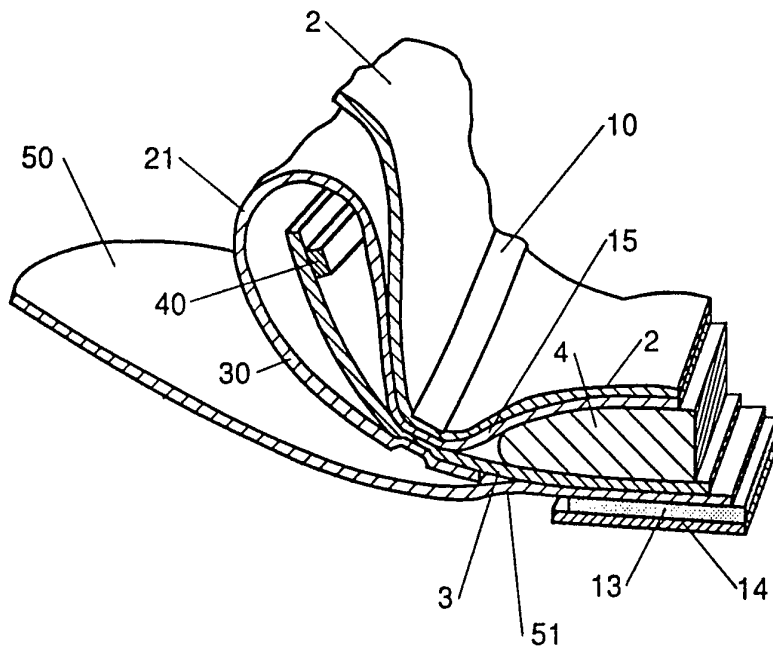

Fig. 8

7/13

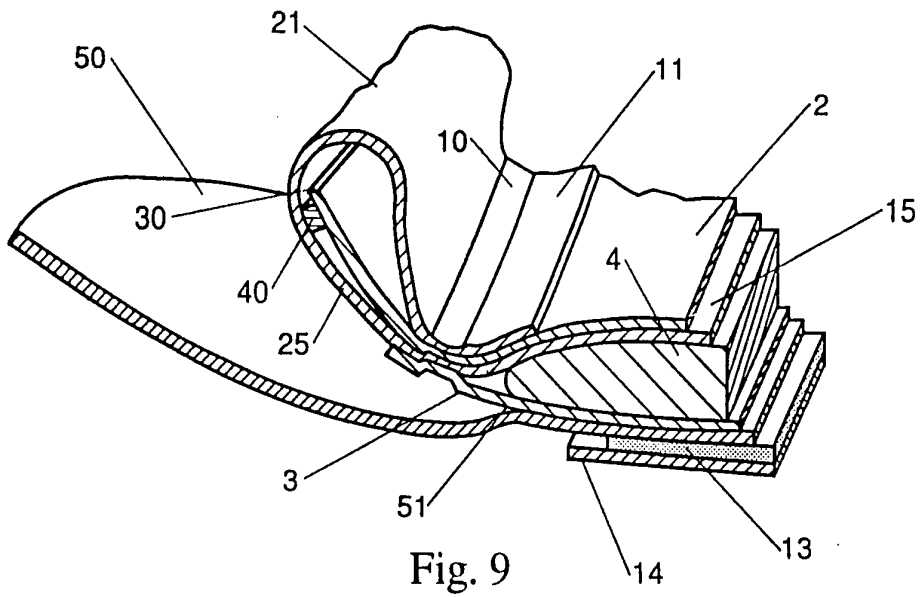

Fig. 9

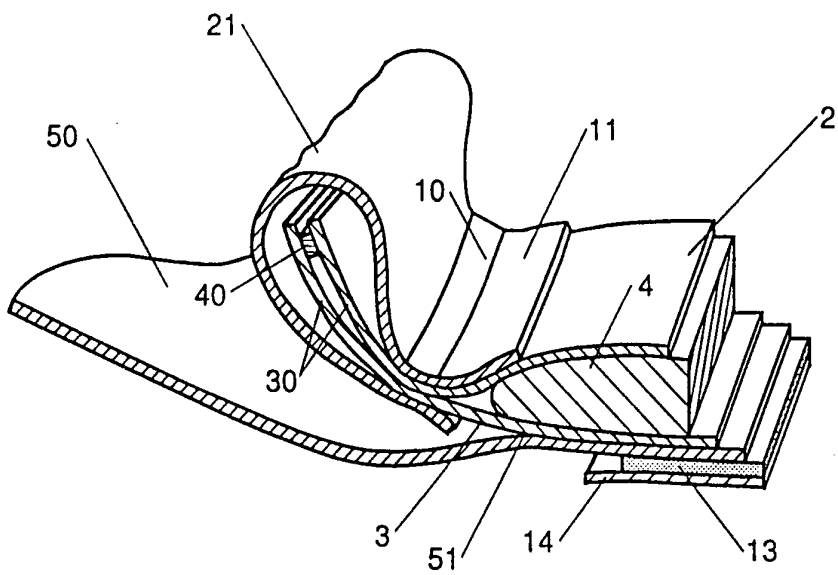

Fig. 10

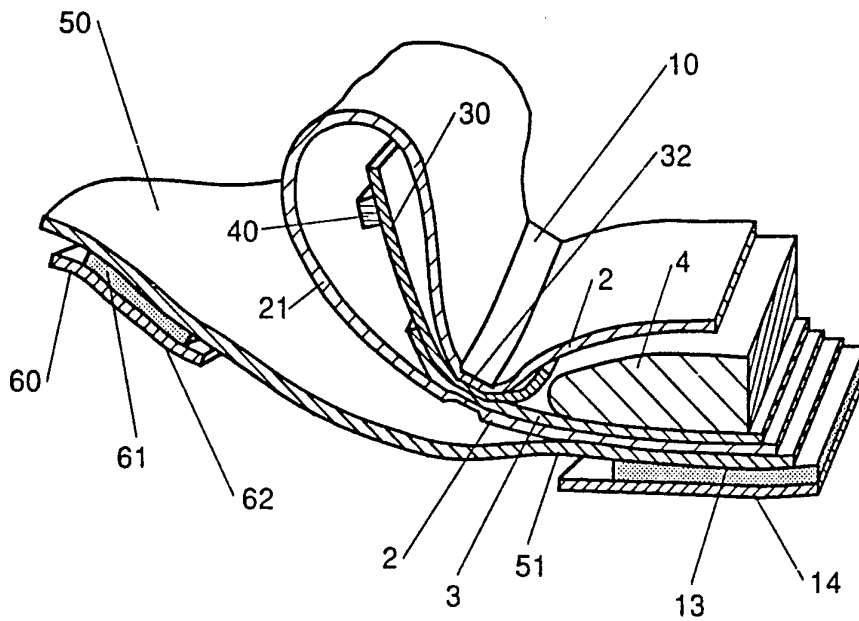

Fig. 11

10/13

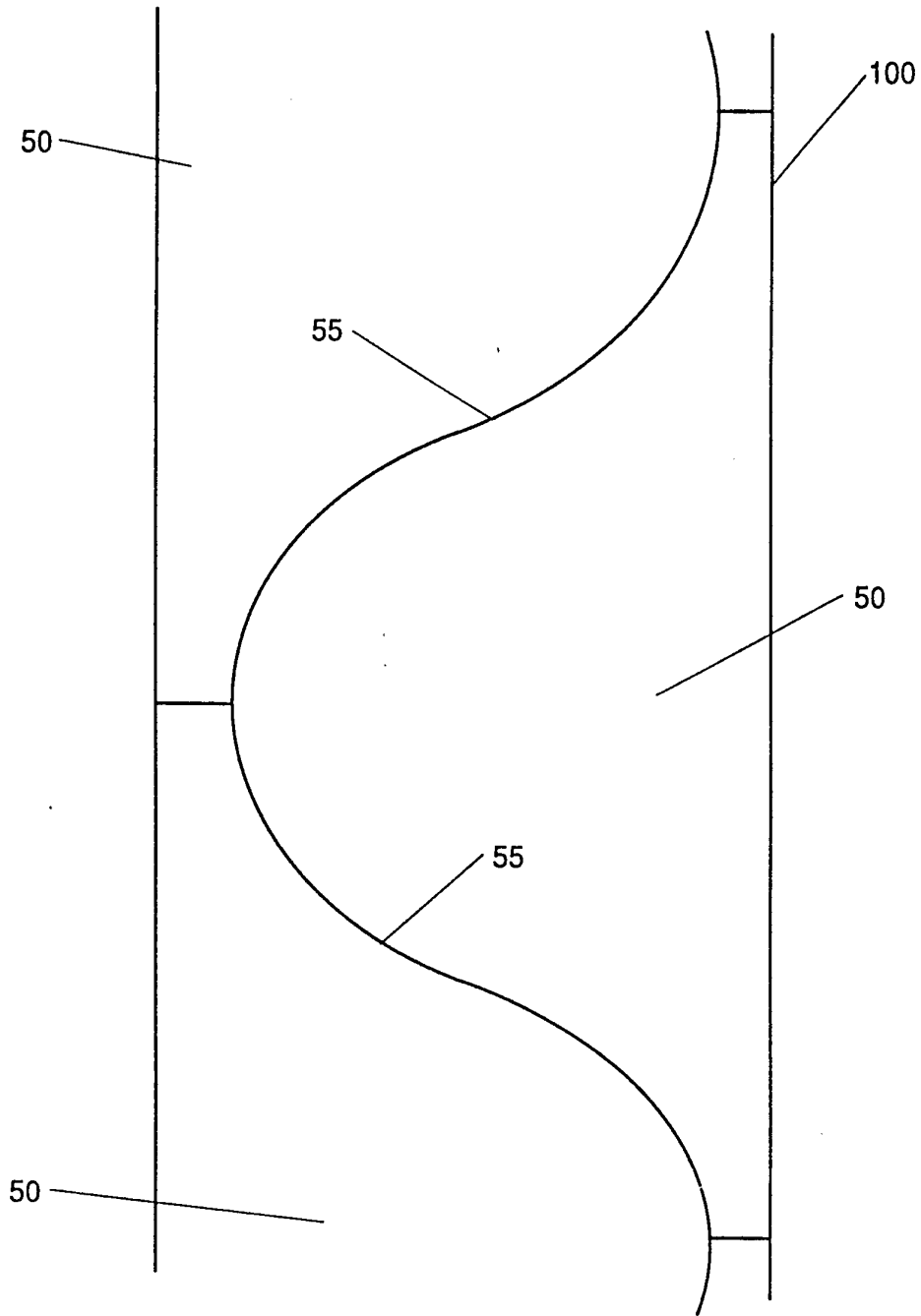

Fig. 13

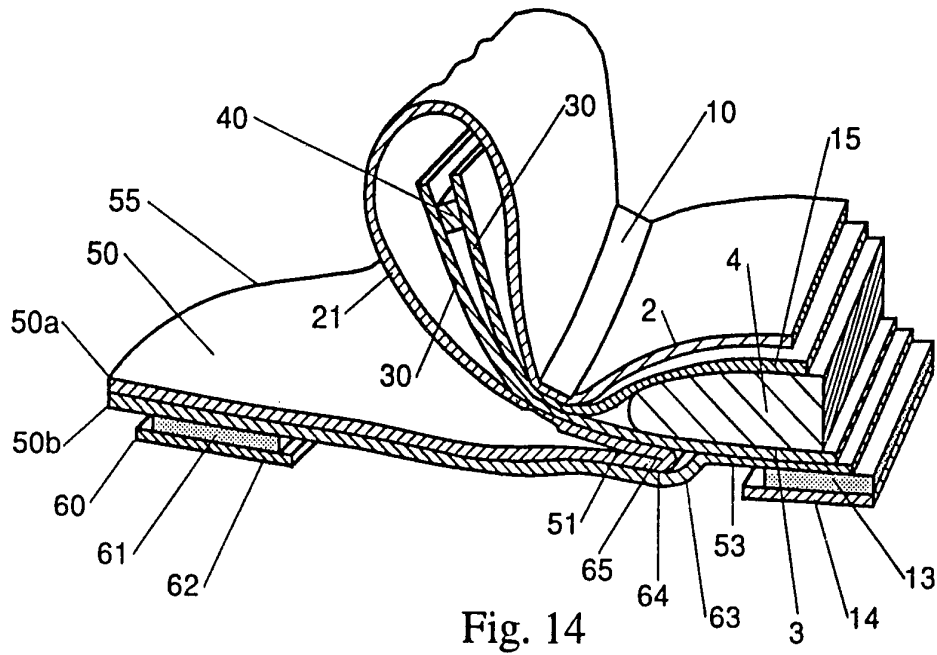

Fig. 14

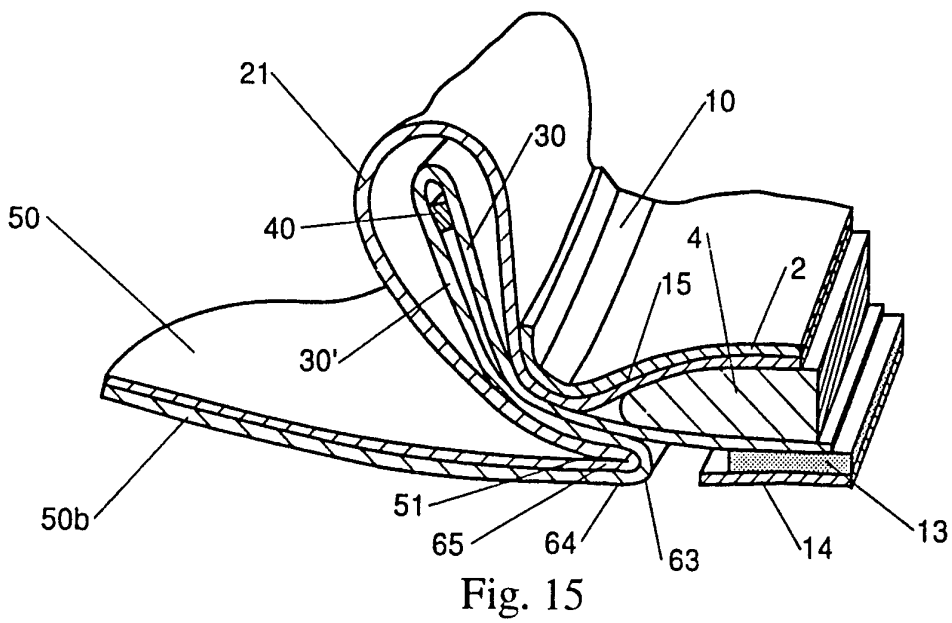

Fig. 15

12/13

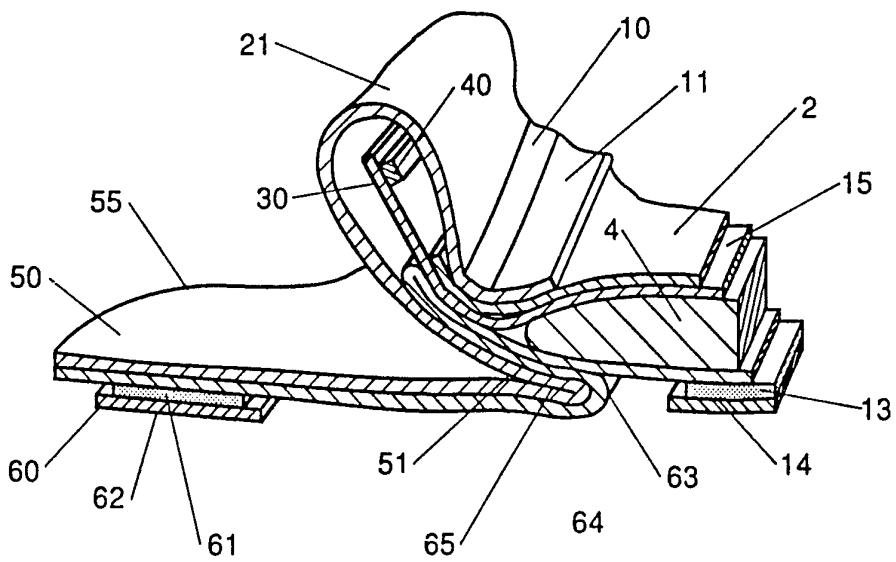

Fig. 16

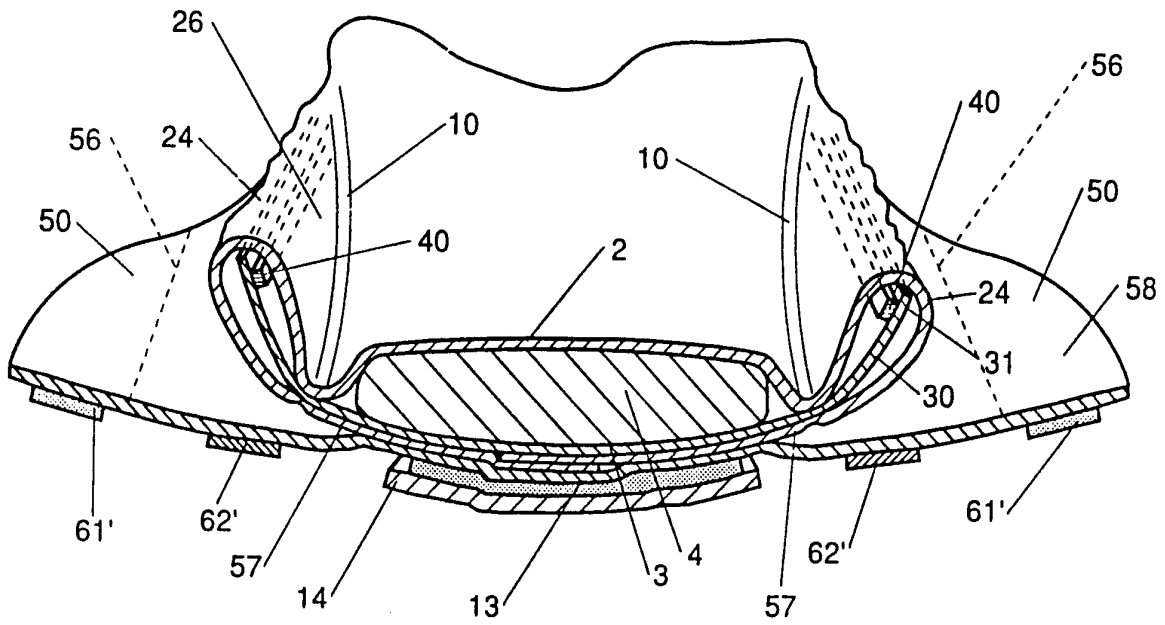

Fig. 17

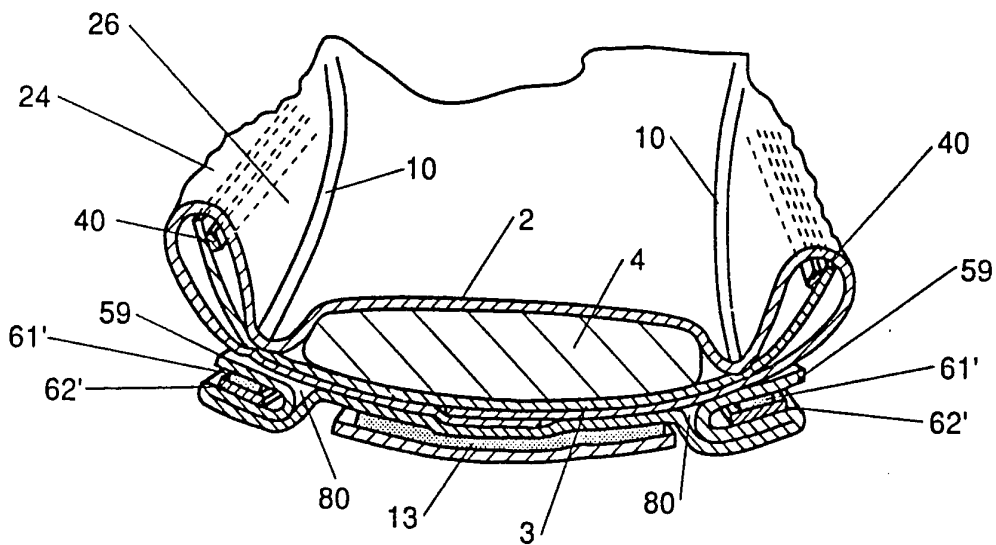

Fig. 18

INTERNATIONAL SEARCH REPORT

International Application No

PCT/US 93/11502

A. CLASSIFICATION OF SUBJECT MATTER
IPC 5 A61F13/15

According to International Patent Classification (IPC) or to both national classification and IPC

B. FIELDS SEARCHED

Minimum documentation searched (classification system followed by classification symbols)
IPC 5 A61F

Documentation searched other than minimum documentation to the extent that such documents are included in the fields searched

Electronic data base consulted during the international search (name of data base and, where practical, search terms used)

C. DOCUMENTS CONSIDERED TO BE RELEVANT

Category*	Citation of document, with indication, where appropriate, of the relevant passages	Relevant to claim No.
P,Y	WO,A,93 10733 (PROCTER & GAMBLE) 10 June 1993 see claims 1-5,8,10; figures ---	1-10
P,Y	WO,A,93 06805 (PROCTER & GAMBLE) 15 April 1993 cited in the application see abstract; figures 2-2A ---	1-10
A	EP,A,0 360 680 (KAYSERSBERG) 28 March 1990 see figure 3 ---	1-5
A	GB,A,2 195 541 (KIMBERLY-CLARK) 13 April 1988 see figure 5 ---	1-4
	-/--	

Further documents are listed in the continuation of box C.

Patent family members are listed in annex.

* Special categories of cited documents :

- "A" document defining the general state of the art which is not considered to be of particular relevance
- "E" earlier document but published on or after the international filing date
- "L" document which may throw doubts on priority claim(s) or which is cited to establish the publication date of another citation or other special reason (as specified)
- "O" document referring to an oral disclosure, use, exhibition or other means
- "P" document published prior to the international filing date but later than the priority date claimed

- "T" later document published after the international filing date or priority date and not in conflict with the application but cited to understand the principle or theory underlying the invention
- "X" document of particular relevance; the claimed invention cannot be considered novel or cannot be considered to involve an inventive step when the document is taken alone
- "Y" document of particular relevance; the claimed invention cannot be considered to involve an inventive step when the document is combined with one or more other such documents, such combination being obvious to a person skilled in the art.
- "&" document member of the same patent family

Date of the actual completion of the international search

24 February 1994

Date of mailing of the international search report

30. 03. 94

Name and mailing address of the ISA

European Patent Office, P.B. 5818 Patentlaan 2
NL - 2280 HV Rijswijk
Tel. (+ 31-70) 340-2040, Tx. 31 651 epo nl,
Fax: (+ 31-70) 340-3016

Authorized officer

Nice, P

INTERNATIONAL SEARCH REPORT

International Application No

PCT/US 93/11502

C.(Continuation) DOCUMENTS CONSIDERED TO BE RELEVANT		
Category *	Citation of document, with indication, where appropriate, of the relevant passages	Relevant to claim No.
A	EP,A,0 426 235 (PROCTER & GAMBLE) 8 May 1991 see abstract; figures 1-5 ---	8
A	EP,A,0 335 527 (PROCTER & GAMBLE) 4 October 1989 cited in the application see abstract; figure 1 -----	8

INTERNATIONAL SEARCH REPORT

Information on patent family members

International Application No

PCT/US 93/11502

Patent document cited in search report	Publication date	Patent family member(s)	Publication date
WO-A-9310733	10-06-93	AU-A- 2956592	28-06-93
WO-A-9306805	15-04-93	AU-A- 2695992 CA-A- 2079511 CA-A- 2079537	03-05-93 02-04-93 02-04-93
EP-A-0360680	28-03-90	FR-A- 2636522 JP-C- 1758815 JP-A- 2121664 JP-B- 4050016 US-A- 5092860	23-03-90 20-05-93 09-05-90 13-08-92 03-03-92
GB-A-2195541	13-04-88	JP-A- 63122451	26-05-88
EP-A-0426235	08-05-91	AU-A- 6567290 CA-A- 2028288 CN-A- 1051856 JP-A- 3191958	09-05-91 02-05-91 05-06-91 21-08-91
EP-A-0335527	04-10-89	US-A- 4917697 AU-A- 3224289 JP-A- 2011140	17-04-90 05-10-89 16-01-90