

(19) World Intellectual Property Organization
International Bureau



(43) International Publication Date
8 July 2010 (08.07.2010)

(10) International Publication Number
WO 2010/077240 A1

- (51) **International Patent Classification:**
G01N 29/44 (2006.01) *G06F 9/44* (2006.01)
- (21) **International Application Number:**
PCT/US2008/088509
- (22) **International Filing Date:**
30 December 2008 (30.12.2008)
- (25) **Filing Language:** English
- (26) **Publication Language:** English
- (71) **Applicant (for all designated States except US):** SIKORSKY AIRCRAFT CORPORATION [US/US]; 6900 Main Street, P.O. Box 9729, Stratford, CT 06615-9129 (US).
- (72) **Inventors; and**
- (75) **Inventors/Applicants (for US only):** WONG, John T. [US/US]; 179 Cleveland Avenue, Bridgeport, Connecticut 06606 (US). URSENBACH, Dan [US/US]; 874 Hill Street, Hamden, Connecticut 06514 (US).
- (74) **Agent:** WISZ, David L.; 400 West Maple Road, Suite 350, Birmingham, MI 48009 (US).

- (81) **Designated States (unless otherwise indicated, for every kind of national protection available):** AE, AG, AL, AM, AO, AT, AU, AZ, BA, BB, BG, BH, BR, BW, BY, BZ, CA, CH, CN, CO, CR, CU, CZ, DE, DK, DM, DO, DZ, EC, EE, EG, ES, FI, GB, GD, GE, GH, GM, GT, HN, HR, HU, ID, IL, IN, IS, JP, KE, KG, KM, KN, KP, KR, KZ, LA, LC, LK, LR, LS, LT, LU, LY, MA, MD, ME, MG, MK, MN, MW, MX, MY, MZ, NA, NG, NI, NO, NZ, OM, PG, PH, PL, PT, RO, RS, RU, SC, SD, SE, SG, SK, SL, SM, ST, SV, SY, TJ, TM, TN, TR, TT, TZ, UA, UG, US, UZ, VC, VN, ZA, ZM, ZW.
- (84) **Designated States (unless otherwise indicated, for every kind of regional protection available):** ARIPO (BW, GH, GM, KE, LS, MW, MZ, NA, SD, SL, SZ, TZ, UG, ZM, ZW), Eurasian (AM, AZ, BY, KG, KZ, MD, RU, TJ, TM), European (AT, BE, BG, CH, CY, CZ, DE, DK, EE, ES, FI, FR, GB, GR, HR, HU, IE, IS, IT, LT, LU, LV, MC, MT, NL, NO, PL, PT, RO, SE, SI, SK, TR), OAPI (BF, BJ, CF, CG, CI, CM, GA, GN, GQ, GW, ML, MR, NE, SN, TD, TG).

Published:
— with international search report (Art. 21(3))

(54) **Title:** NON-DESTRUCTIVE INSPECTION METHOD WITH OBJECTIVE EVALUATION

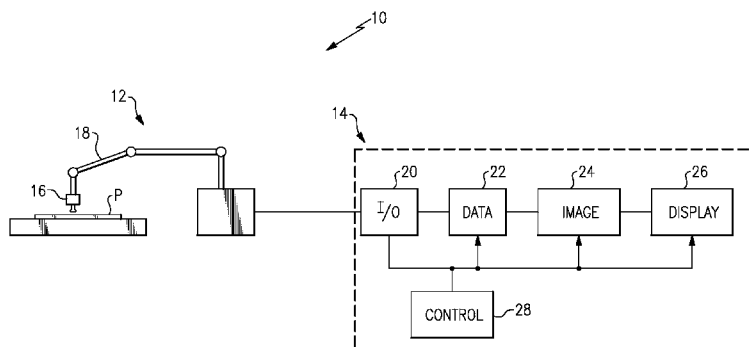

FIG. 1

(57) **Abstract:** A method of non-destructive inspection evaluation includes converting a scan file of a part into a text file, determining whether the signal attenuation representative value is greater than a predetermined value and outputting a numeric score related to the signal attenuation representative value to signify a defect.

WO 2010/077240 A1

NON-DESTRUCTIVE INSPECTION METHOD WITH OBJECTIVE EVALUATION

BACKGROUND

[0001] The present application relates to a non-destructive inspection method, and
5 more particularly to an automated process to objectively evaluate a test scan.

[0002] Ultrasonic Test (UT) scans are performed on various aerospace components
such as composite tail rotor spars of a rotary-wing aircraft. When the UT scan is complete, a
color-coded map is displayed and an inspector visually reviews the UT scan. The inspector
subjectively decides the periphery of each defect based on comparison with a standard to
10 determine whether predefined acceptance criteria have been achieved. The decision based on the
predefined acceptance criteria results in a pass/fail indication.

[0003] The procedure may be time consuming and somewhat arbitrary as the result is
at least partially subjective and dependant upon the inspector. Moreover, the variability may
compromise the establishment of process improvement and quality trend data over the multitude
15 of inspectors and the associated subjectivity.

SUMMARY

20 [0004] A method of non-destructive inspection evaluation according to an exemplary
aspect of the present application includes: converting a scan file of at least a particular section of
a part into a text file; evaluating the text file for a signal attenuation representative value within
the particular section of the part; determining whether the signal attenuation representative value
25 is greater than a predetermined value; and outputting a numeric score related to the signal
attenuation representative value to signify a defect.

30

BRIEF DESCRIPTION OF THE DRAWINGS

[0005] Various features will become apparent to those skilled in the art from the following detailed description of the disclosed non-limiting embodiment. The drawings that accompany the detailed description can be briefly described as follows:

5 [0006] Figure 1 is a schematic block diagram of a non-destructive inspection system;

[0007] Figure 2 is a flow chart which executes ScanScore software according to the present application with ultrasonic test (UT) scans obtained from an acquisition system;

[0008] Figure 3 is a plan view of a representative spar which is separated into sections for analysis through an ultrasonic test (UT) scan;

10 [0009] Figures 4A-4G illustrate different layers of an ultrasonic test (UT) scan which represent several "channels" of the UT scan;

[0010] Figure 5 is a screen shot which illustrates a multitude of representative spars which are to be analyzed by the ScanScore software;

15 [0011] Figure 6 is an example scan of a part that has porosity in both pad regions (at approximately $\frac{1}{4}$ and $\frac{3}{4}$ along the length of the part);

[0012] Figure 7 is an example scan of a part that has fiberwash in the "wrist" region (at approximately $\frac{1}{3}$ along the length of the part); and

[0013] Figure 8 is a chart which illustrates summary data of a representative spar with respect to the mold utilized in fabrication thereof.

20

DETAILED DESCRIPTION

[0014] Figure 1 schematically illustrates a non-destructive inspection system 10. The non-destructive inspection system 10 generally includes an acquisition system 12 and a computer system 14 in communication therewith. The acquisition system 12 may provide an ultrasonic test (UT) scan, X-ray scan, or other map-based scan for objective evaluation through software within the computer system 14.

[0015] The software, referred to herein as ScanScore, gathers, processes, and analyzes the parts scanned by the non-destructive inspection system 10 to determine whether each part, or

section thereof will “pass” or “fail” dependant on the colors and patterns in the scan relative to predetermined requirements.

[0016] The acquisition system 12 for a UT scan generally includes a probe 16 mounted to a mechanical arm 18 whose movement is precisely controlled by the computer system 14. The mechanical arm 18 is controlled to move the probe 16 over the surface of a part P. As the probe 16 moves across the part P, ultrasonic test data is taken at preprogrammed data points. While the data points are typically equally spaced, the computer system 14 may alternatively be programmed to take data at irregular distances. The acquisition system 12, in addition to one or more probes 16 may include interface electronics and an electromechanical apparatus to move the probe 16 across the surface of the part. The acquisition system 12 may also include position sensors that monitor the position of the probe 16.

[0017] The computer system 14 may include an interface 20, a data processor 22, an image processor 24, a display 26, and a control system 28. The interface 20 communicates with the probe 16 to communicate signals from the probe 16 to the data processor 22. The data processor 22 generates data in response to the signals provided from the interface 20. The data from the data processor 22 may be utilized such that the image processor 24 will output an image signal in response to the data produced by the data processor 22. The display 26 may be utilized with the control system 28 by a user to display image and other data from the data processor 22 and the image processor 24 as well as program and control the acquisition system 12.

[0018] The data processor 22 may include, for example, a processor and a memory device which, in response to a command issued from the control system 28, processes the signal from the interface 20 and generates data from the part P. For example, the data processor 22 performs a logarithmic amplification for the echo signal outputted from the probe 16, detects an envelope therefrom and generates data representative thereof. Numerical values may be assigned to the amount of signal attenuation for use in, for example, ASCII files.

[0019] The image processor 24 may include, for example, a processor and a memory device which, in response to a command issued from the control system 28, processes the signal from the interface 20 and generates an image on the display 26. The image processor 24 generates image data in predetermined channels and stores the generated image data into memory whereby a multi-dimensional dynamic image display or the like is effectuated. For

example, colors may be mapped as representative of signal attenuation and utilized as the image data.

[0020] The display 26 includes, for example, a screen for the display of an ultrasonic image. The display 26 may be based on technologies such as cathode-ray tubes, liquid-crystal
5 displays, organic light-emitting diodes, or other technologies.

[0021] The control system 28 is provided with, for example, a keyboard and a pointing device which, in accordance with an input operation, outputs a control signal. The control system 28 may be coupled to system interface and may include input devices, inclusive of but not limited to, a keyboard, mouse, scanner, microphone, camera, proximity device, etc.
10 Further, the control system 28 may also include output devices, inclusive of but not limited to, a printer, storage, etc. Finally, the control system 28 may further include devices that communicate both as inputs and outputs, inclusive of but not limited to, a modulator/demodulator for accessing another device, system, or network, a radio frequency (RF) or other transceiver, a telephonic interface, a bridge, a router, etc.

[0022] The acquisition system 12, in one non-limiting embodiment, may be of the form of any non-destructive test equipment inclusive of, but not limited to, ultrasonic test equipment operable to provide an ultrasonic test (UT) scan of various materials for discontinuities. Such discontinuities may include flaws, a void or area of resin porosity, a delamination, foreign matter, or a change in stiffness caused by a composite ply formed of an
20 unacceptable material, etc. As is well known to those skilled in the ultrasonic test art, different types of industrial ultrasound tests may be used to conduct, for example, through transmission ultrasound (TTU) and pulse echo (PE) ultrasound tests. In a TTU test, sound waves produced by an ultrasonic transmitter located on one side of the test part and received by a receiver located on the opposite side of the part pass completely through the test part. PE ultrasound test apparatus
25 uses a single transducer located on one side of the test part that functions as both a transmitter and a receiver. Pulse echo testing requires access to only one side of the test part.

[0023] Referring to Figure 2, the computer system 14 may be utilized to execute the ScanScore software with ultrasonic test (UT) scans obtained from the acquisition system 12. It should be understood that the computer system 14 may be in direct communication with the
30 acquisition system 12 or may be remote therefrom such that the computer system 14 will store

data such as scan files from the acquisition system 12 to be processed at a separate workstation. In Figure 2, the operation of the ScanScore software is disclosed in terms of functional block diagrams.

5 [0024] Initially, an ultrasonic test (UT) scan is performed on each part (step 100). In this particular embodiment, the part is a tail rotor spar, however, various parts will also be usable herewith. The ultrasonic test (UT) scan is herein referred to as a scan file which may be associated with each part such as by serial number then stored in memory for later operations. It should be understood that the scan file may be obtained from various sources.

10 [0025] The scan files are converted into an image file (a representation of which is shown in Figure 3) and a text file (Step 102). The scan files are the files output from the acquisition system 12. The image file may be a digital picture file for visual review and comparison. The text file may be an all text file such as an ASCII file. In one non-limiting embodiment, the text file is the file upon which the ScanScore software operates, although any other file type such as a binary file type may be used. The files are essentially equivalent in the information contain therein, but the image file is a visual reference of the text file so, for example, a section of the part would be represented by a grid of X points by Y points. Each point would have a numeric value which represents the signal attenuation at that given point. The numeric values are mapped as an image file in which the signal attenuation is represented by a color scale. The image file may contain multiple layers, each of which is representative of
15 different "channels" provide by the UT scan. (Figures 4A-4G). Higher signal attenuation, for example, may be represented by black and progressively lower signal attenuation would proceed along a color scale. Particular colors may represent areas where signal attenuation is significant. That is, certain colors might be representative of voids or improperly oriented fibers.

25 [0026] Once all the scan files are converted into a respective image file and text file, particular parts of interest are selected (step 104). The parts may, for example, be selected in response to parts fabricated during a particular time period, fabricated based upon a particular raw material batch, etc.

30 [0027] The parts may be referenced through serial numbers as significant environmental information is typically tracked during manufacture and related to serial number. Furthermore, the scan file name might have an extension or other extraneous information.

Through renaming of the file, each file may be identified by just the serial number such that each file is uniquely identified. The particular parts of interest may be input into a spreadsheet format in which the serial numbers are utilized to reference the parts (Figure 5). For example only, tens of thousands of parts may have been scanned over a production run, but only the parts fabricated
5 in a particular month may be selected.

[0028] The ScanScore software proceeds through the particular parts of interest selected in step 104 (Step 106). The ScanScore software first obtains the ASCII file associated with the first part of interest and opens that file.

[0029] The ScanScore software opens the particular ASCII file and determines the
10 perimeter of the part (Step 108). That is, the UT scan is typically provided in X-Y coordinates over a rectangular pattern but the part itself will likely fall within the rectangular pattern. Without finding the perimeter for each part, there may be a risk of analyzing the wrong areas, not correctly relating the particular sections of the parts, or analyzing an area where there is no part at all. This may not be essential if each part is indexed to the same position on the acquisition
15 system 12, but the perimeter identification assures any discrepancies are minimized or eliminated. The perimeter of the part is determined by finding the portion of the scan where there is a jump in signal attenuation, which is indicative of the start of a part. In the particular case of tail rotor spars, we take a jump of at least 50 units on a 0-255 scale of signal attenuation as the boundary of a part.

[0030] The perimeter of the part may be further defined into sections by the
20 coordinates on the part. For example, the sections of the example spar are separated into right and left outboard sections, pad sections, wrist sections, torpedo sections and a center section (Figure 3). Each section may defined by the design blueprint to have a permitted defect allocation.

[0031] The ScanScore software evaluates each section of the part for porosity by
25 evaluating the text file for porosity defect (Step 110). That is, the text file is evaluated to determine a signal attenuation representative value which equates to any anomaly within the particular section. The anomaly is a determination of whether a value of the signal attenuation and the area of signal attenuation are greater than a predetermined value and area within each
30 particular section of the part.

[0032] Signal attenuation also correlates to part thickness, among other characteristics such as density, surface roughness, etc. Because the part thickness varies in spars, there is a need to use a different number as the cutoff for signal attenuation that signifies a defect. ScanScore is calibrated to count the number of instances/pixels of signal below a threshold value, where the
5 threshold value varies with the part thickness. The threshold value was chosen for each section of the part so that in one non-limiting embodiment, a value of 1000 “bad” pixels will display “FAIL” in the spreadsheet. Alternatively, the same threshold value can be used for all sections and the number of “bad” pixels required to “FAIL” a part can be varied. A particular section of a part may be discounted if there is a known factor that may cause signal attenuation. For
10 example, near the center of each spar, there is a thermocouple installed. The thermocouple causes a discontinuity in part thickness, part density, and fiber orientation. These all cause different signal attenuation as compared to the surrounding area.

[0033] The predetermined value and area are typically defined by the design blueprint in which an anomaly such as a particular porosity defect is permitted within each section. The
15 porosity defect is representative of voids which are represented by the signal attenuation. That is, if there is less signal in one area than another and the areas are of equivalent material and thickness, the signal attenuation would be indicative of a void, delamination or some other type of discontinuity referred to herein as a porosity defect (Figure 6).

[0034] The ScanScore software then evaluates the text file for another predetermined
20 anomaly such as a fiberwash defect (Step 112). The fiberwash defect is a determination of whether the signal attenuation is of a cyclic variation. That is, if the fiber reinforcements in the part are wavy or otherwise distorted, there is a periodic or cyclic signal attenuation (Figure 7). One way to detect this type of defect is to identify and locate all of the areas where there is signal attenuation, then check for periodicity in the pattern of the defects. For example, the center of
25 each defect may be located and the distance between them may be analyzed for patterns. The signal attenuation of each defect may be less than that required to be classified as a porosity defect, though it need not be less (i.e., pattern matters more than level of signal attenuation in this case). Typically, the cyclic variation or other pattern effect is readily identifiable by the ScanScore software. Furthermore, other patterns may be predefined for identification within
30 each section of the part.

[0035] The ScanScore software then outputs a numeric score for porosity defect and fiberwash defect for each section of the part (Step 114). That is, an objective interpretation is provided for the amount of porosity defect and the amount of fiberwash defect which are translated into a numeric score for each section. Each part is associated with a series of numeric scores for each section of the part.

[0036] Alternatively, or in addition thereto, a multiple of scores may be combined into a single score. There are many methods that the scores can be combined. One method is to simply add the scores together, but this may assign lower than expected scores if there are many small but acceptable defects. Another way is to assign a simple "PASS" or "FAIL" to each section and have the final score reflect whether every section is acceptable, resulting in a "PASS" if all sections are acceptable and resulting in a "FAIL" if any one or more sections are not acceptable. This method gives an accurate account of whether a spar is acceptable, but does not provide as much information about the part. The scores can be weighted and averaged. For example, if a particular section of the part is of more interest than the rest for a particular analysis, but a general sense about that the remainder of the part is desired, more weight can be placed on the section of interest and less on the other sections. Scores may also be combined for multiple spars. If the performance of a particular batch of material is desired, for example, all the scores of the spars from that batch may be combined for a total score and compared to the total score of other batches of material.

[0037] Most parts have different criteria for different sections of the part. For the spar described herein, sections closer to the root ends generally experience higher loads such that a smaller allowable defect is permitted than the tip sections. Portions that are thinner generally experience a higher stress because even though the load is equivalent there is less cross-sectional area and a smaller allowable defect is permitted. Sections that are outboard or sections that are relatively thick generally experience a lower stress and have a larger allowable defect. Sections that are subjected to higher torsional stresses usually have a smaller allowable defect. It should be understood that various sections for various parts would have particular allowable defects which are defined by blueprint requirements translated into numeric scores. Furthermore, known sized defects in a template of flawed parts may be utilized to "calibrate" the measurements and allowable defects to determine the numeric scores. That is, predetermined porosity defects and

fiberwash defects may be used to define a numeric score, and thereby relate a calculated numeric value for each measured part to an acceptable porosity defects and/or fiberwash defect so that the measured part may be identified as "passing" or "failing" inspection. The ScanScore software then loops through each additional part of interest selected in step 104 (Steps 116, 118). The ScanScore software thereby determines whether each part "passes" or "fails" based on the objective numeric criteria. Such determinations avoid the subjective evaluation typical of human inspection methods.

[0038] The ScanScore software may then be utilized to generate summary data to facilitate identification trends (Step 120). The ScanScore software generates summary data and charts to allow detection of singular or patterns in defects across, for example only, tools, environmental conditions, personnel, etc.

[0039] Referring to Figure 8, the ScanScore software provides a summary output. An example conclusion may be that there is an issue with mold #6, which produces more pad porosity than the others. The chart identifies differences between molds, but the ScanScore software may alternatively be utilized to display, for example only, differences between material batches, days of the week, environmental conditions, etc. The chart of Figure 8 is with reference to pad porosity, but other charts may be selected to plot fiberwash in the pad and other defects in other sections of the part in a summary type format.

[0040] It should be understood that relative positional terms such as "forward," "aft," "upper," "lower," "above," "below," and the like are with reference to the normal operational attitude of the vehicle and should not be considered otherwise limiting.

[0041] It should be understood that like reference numerals identify corresponding or similar elements throughout the several drawings. It should also be understood that although a particular component arrangement is disclosed in the illustrated embodiment, other arrangements will benefit herefrom.

[0042] Although particular step sequences are shown, described, and claimed, it should be understood that steps may be performed in any order, separated or combined unless otherwise indicated and will still benefit from the present invention.

[0043] The foregoing description is exemplary rather than defined by the limitations within. Various non-limiting embodiments are disclosed herein, however, one of ordinary skill

in the art would recognize that various modifications and variations in light of the above teachings will fall within the scope of the appended claims. It is therefore to be understood that within the scope of the appended claims, the invention may be practiced other than as specifically described. For that reason the appended claims should be studied to determine true
5 scope and content.

CLAIMS

What is claimed is:

1. A method of non-destructive inspection evaluation of a part comprising:
5 converting a scan file of at least a particular section of a part into a text file;
evaluating the text file for a signal attenuation representative value within the particular
section of the part;
determining whether the signal attenuation representative value is greater than a
predetermined value; and
10 outputting a numeric score related to the signal attenuation representative value to
signify a defect.
2. A method as recited in claim 1, further comprising:
associating the predetermined value with a porosity defect value;
15 identifying that a porosity defect is associated with the particular section of the part in
response to a determination that the signal attenuation representative value is
greater than the predetermined value.
3. A method as recited in claim 2, further comprising:
20 relating the predetermined value to a calibrated porosity defect value.
4. A method as recited in claim 2, further comprising:
identifying the part as failed for porosity defect in response to a determination that the
signal attenuation representative value is greater than a predetermined value.

25

5. A method as recited in claim 1, further comprising:
associating the predetermined value with a cyclic variation; and
identifying that a fiberwash defect is associated with the particular section of the part in
response to a determination that the signal attenuation representative value is
greater than the predetermined value.

5

6. A method as recited in claim 5, further comprising:
relating the predetermined value to a calibrated fiberwash defect value.

10

7. A method as recited in claim 5, further comprising:
identifying the part as a failed part for fiberwash defect in response to a determination
that an area of the cyclic variation and signal attenuation in the area meet a
predetermined criterion.

15

8. A method as recited in claim 1, further comprising:
storing a numeric score for each of a multiple of parts, the numeric score including at
least one signal attenuation representative value; and
grouping the numeric scores for each of the multiple of parts by at least one parameter.

20

9. A method as recited in claim 8, further comprising:
grouping the numeric scores for each of the multiple of parts by a mold number.

10. A method as recited in claim 8, further comprising:
determining a trend from the numeric scores for each of the multiple of parts by the at
least one parameter.

25

11. A method as recited in claim 1, further comprising:
correlating the numeric value to a part characteristic.

30

12. A method as recited in claim 1, further comprising:
relating the part characteristic to part thickness.

5 13. A method as recited in claim 11, further comprising:
converting the scan file of the part into an image file of the part; and
storing the image file of the part for display to a user.

10 14. A method as recited in claim 1, further comprising:
performing an ultrasonic test on the part to generate the scan file.

15. An apparatus for carrying out the process of any of claims 1-14.

15 16. A program product embodied on a machine-readable medium containing
executable instructions for performing the process of any of claims 1-14.

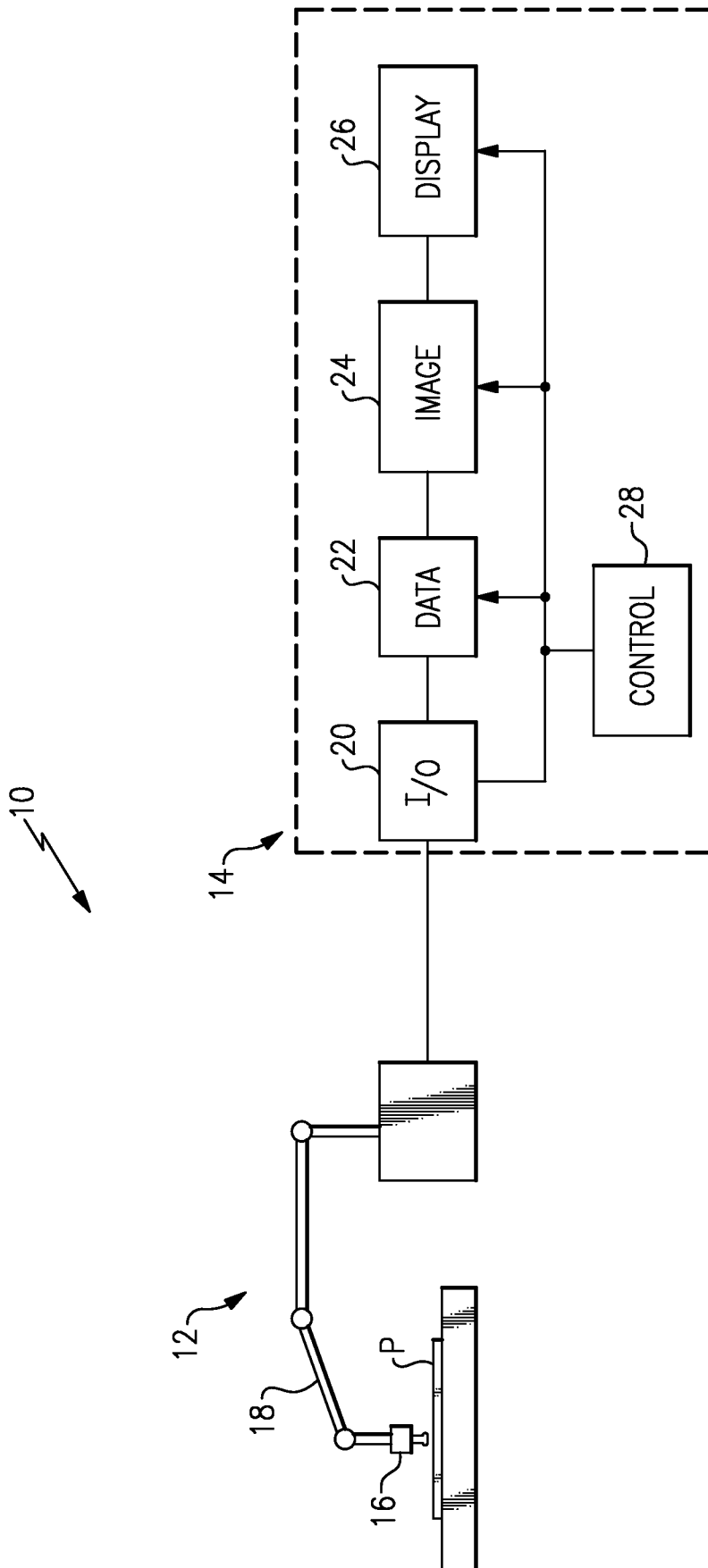
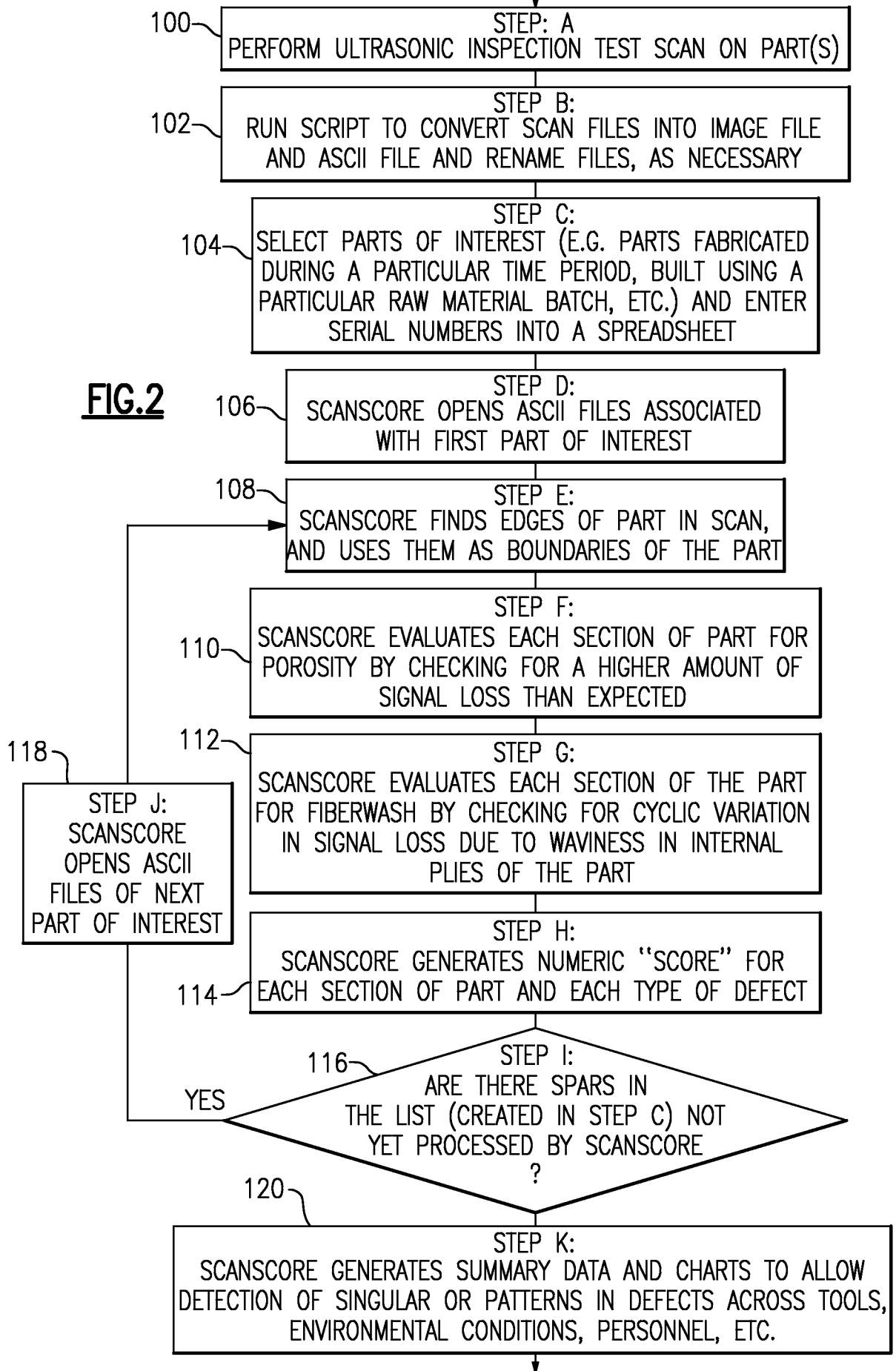

FIG.1

2/9



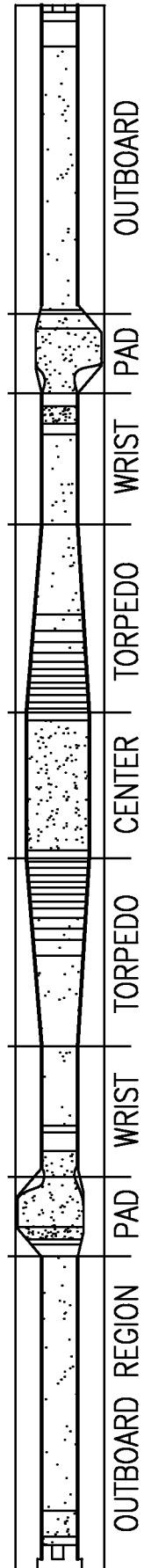

FIG. 3

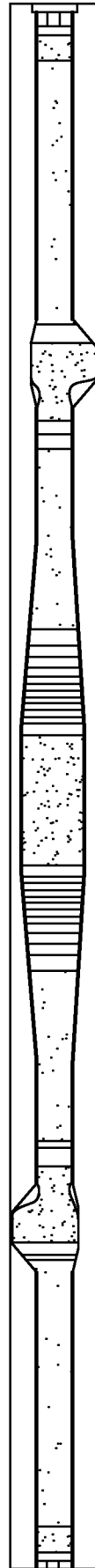

FIG. 4A

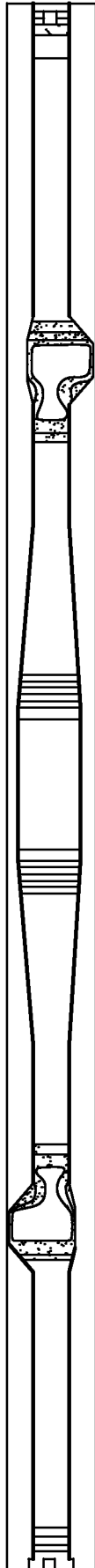

FIG. 4B

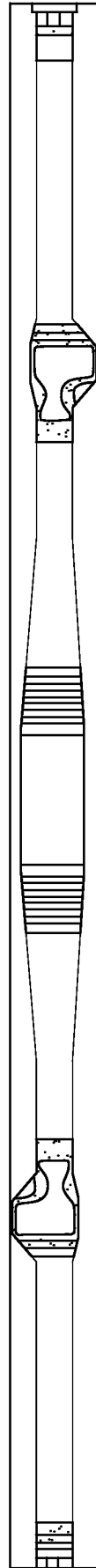

FIG. 4C

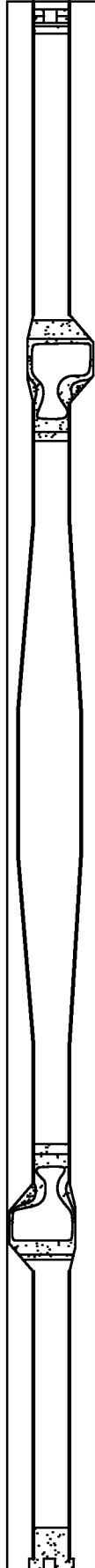

FIG. 4D

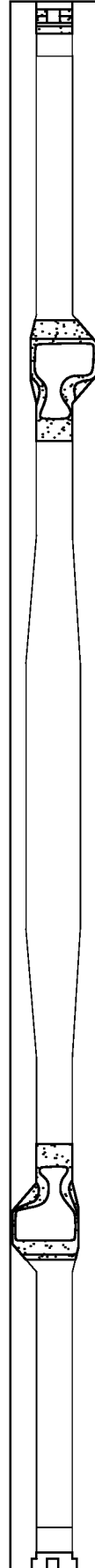

FIG. 4E

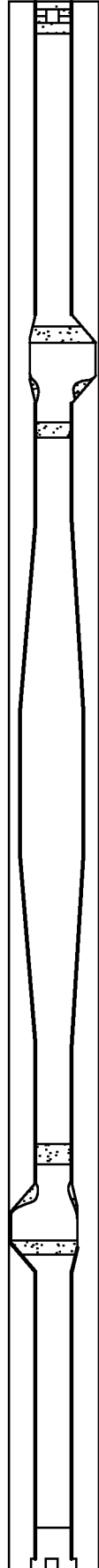

FIG. 4F



FIG. 4G

Microsoft Excel-ScanScore_v2.1.xls

File Edit View Insert Format Tools Data Window Help

100% Arial 10 B I U

D:\Documents and Settings\34188\My Documents\John\H-60\Scan

	A	B	C	D	E	F	G	H	I	J	K
1		Pad A			Pad B						
2	Serial No	s Mean	Std. Dev	Pixels	Mean	Std. Dev	Pixels	Pass/fail			
3	13758	49.28448	3.175466	116	50.55357	3.484614	56	<--Good!			
4	13759	48.91379	4.433859	58	53.94118	0.242536	17	<--Good!			
5	13760	50.29444	4.357553	360	49.66151	3.647157	582	<--Good!			
6	13761	50.56892	2.734414	399	45.89076	5.712096	476	<--Good!		Run FiberwashScan	
7	13762	52.37838	1.348764	111	49.24324	3.906554	185	<--Good!			
8	13763	49.67822	2.169536	202	50.47619	2.287166	42	<--Good!			
9	13764	50	0	0	47.2193	3.388577	114	<--Good!			
10	13765	51.85366	1.55822	41	47.07623	3.280919	223	<--Good!			
11	13766	50.49505	3.53447	101	49	3.809425	513	<--Good!			
12	13767	49.49096	5.401189	387	46.0884	5.215991	724	<--Good!			
13	13768	45.52119	5.907404	236	48.26455	4.371555	189	<--Good!			
14	13769	52.85	1.565248	20	47.43883	5.450527	376	<--Good!			
15	13770	48.70763	3.130377	236	51.90426	2.644	94	<--Good!			
16	13771	52.57616	1.00291	151	49.09081	3.771017	377	<--Good!			
17	13772	48.90164	2.711625	183	50.34969	2.765604	163	<--Good!			
18	13773	48.56647	5.197818	346	49.71912	4.508009	502	<--Good!			
19	13774	48.20183	7.032701	109	50	2.119675	216	<--Good!			
20	13775	52.86458	1.244946	96	53.12308	1.663089	65	<--Good!			
21	13776	51.97321	1.833974	336	48.81728	4.329338	301	<--Good!			
22	13777	46.05085	5.349091	118	43.33333	5.954877	132	<--Good!			
23	13778	51	3.095696	25	49.98876	3.084029	89	<--Good!			
24	13779	45.14836	7.377047	701	46.47117	6.802547	1110	<--Fail			
25	13780	51.71429	2.968886	21	49.34848	2.606465	132	<--Good!			
26	13781	52.97674	1.595953	43	50.44706	3.15293	170	<--Good!			
27	13782	51	3.165075	114	51.29508	2.571279	61	<--Good!			
28	13783	49.06186	4.225817	679	48.4412	4.855538	1403	<--Fail			
29	13784	50.14103	2.030251	156	50.87023	2.315157	131	<--Good!			
30	13785	48.47253	5.075868	182	50.50877	4.227549	228	<--Good!			

FIG.5

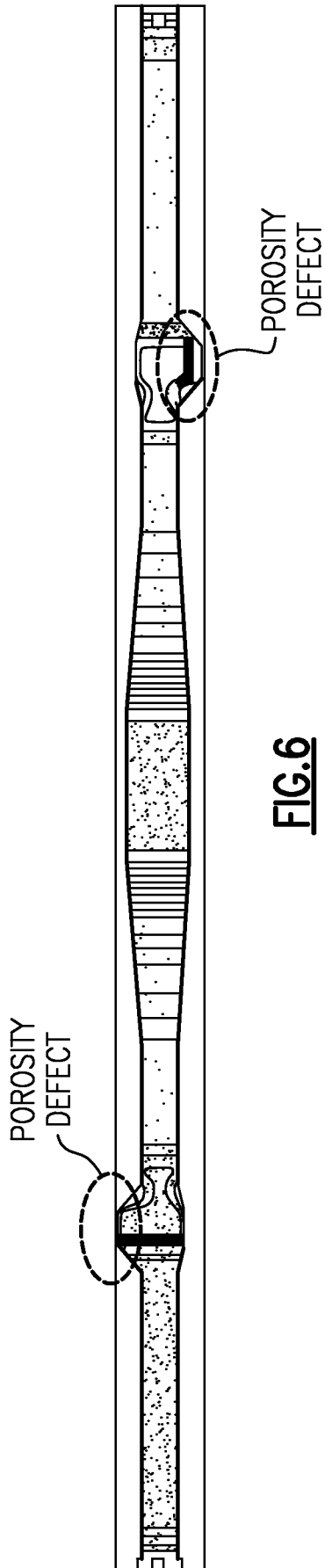

FIG. 6

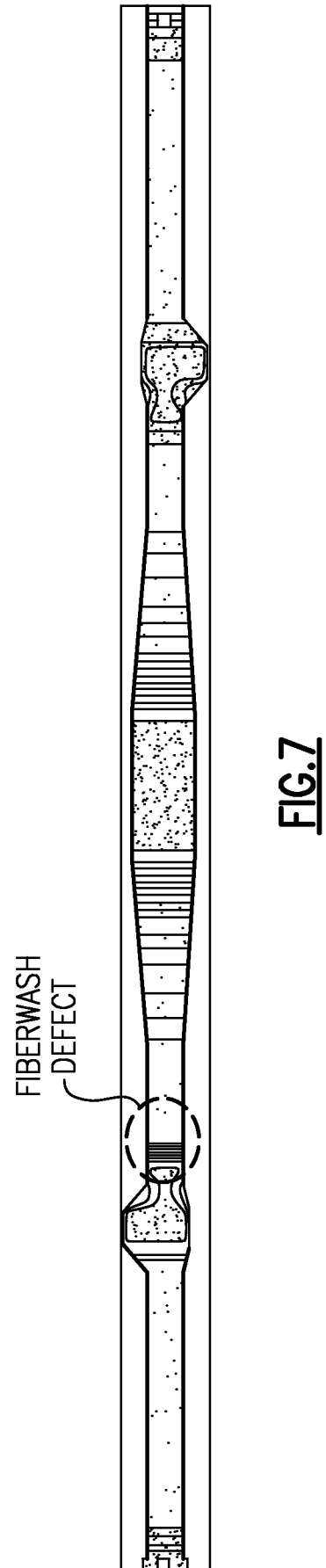

FIG. 7

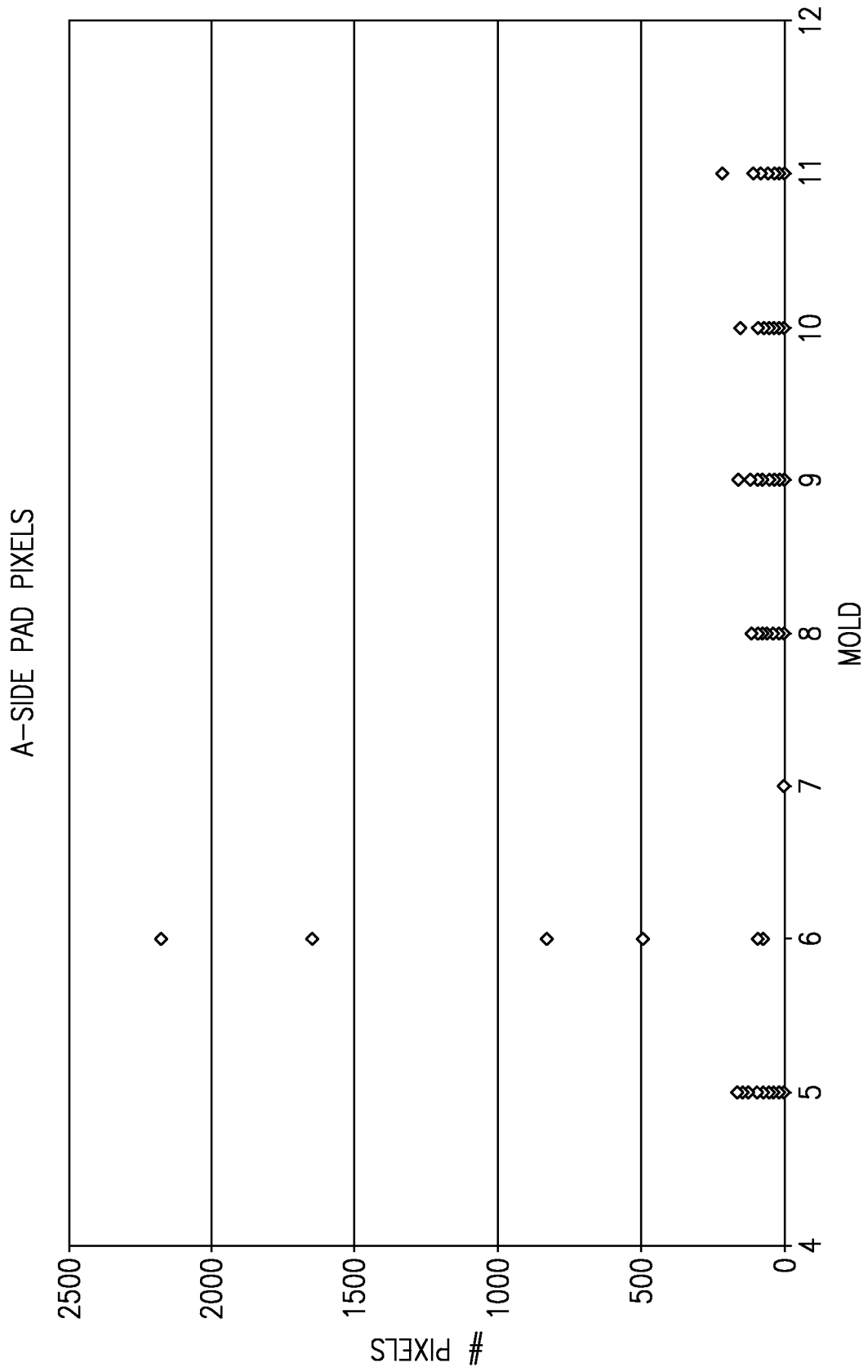



FIG.8

INTERNATIONAL SEARCH REPORT

International application No.
PCT/US2008/088509

A. CLASSIFICATION OF SUBJECT MATTER		
<i>G01N 29/44(2006.01)i, G06F 9/44(2006.01)i</i>		
According to International Patent Classification (IPC) or to both national classification and IPC		
B. FIELDS SEARCHED		
Minimum documentation searched (classification system followed by classification symbols) IPC: G01N 29/00, G01N 29/04, G01N 29/06, G01N 29/18		
Documentation searched other than minimum documentation to the extent that such documents are included in the fields searched Korean Utility models and applications for Utility Models since 1975 Japanese Utility models and applications for Utility Models since 1975		
Electronic data base consulted during the international search (name of data base and, where practicable, search terms used) eKIPASS (KIPO internal) & keywords: "ultrasonic test", "attenuation", "defect"		
C. DOCUMENTS CONSIDERED TO BE RELEVANT		
Category*	Citation of document, with indication, where appropriate, of the relevant passages	Relevant to claim No.
X	US 5824908 A (SCHINDEL, D. W. & HUTCHINS, D. A.) 20 OCTOBER 1998 See abstract; Figs.1-3; claims	1,8-11,13-16
Y		2-4,12
Y	US 5591913 A (TUCKER, J. R. et al.) 07 JANUARY 1997 See column 7, lines 16 - 24	2-4
Y	US 4487072 A (LIVINGSTON, W. A.) 11 DECEMBER 1984 See abstract; Fig.1; claims	12
A	US 5777891 A (PAGANO, D. et al.) 07 JULY 1998 See the whole document	1-16
<input type="checkbox"/> Further documents are listed in the continuation of Box C. <input checked="" type="checkbox"/> See patent family annex.		
* Special categories of cited documents: "A" document defining the general state of the art which is not considered to be of particular relevance "E" earlier application or patent but published on or after the international filing date "L" document which may throw doubts on priority claim(s) or which is cited to establish the publication date of citation or other special reason (as specified) "O" document referring to an oral disclosure, use, exhibition or other means "P" document published prior to the international filing date but later than the priority date claimed "T" later document published after the international filing date or priority date and not in conflict with the application but cited to understand the principle or theory underlying the invention "X" document of particular relevance; the claimed invention cannot be considered novel or cannot be considered to involve an inventive step when the document is taken alone "Y" document of particular relevance; the claimed invention cannot be considered to involve an inventive step when the document is combined with one or more other such documents, such combination being obvious to a person skilled in the art "&" document member of the same patent family		
Date of the actual completion of the international search 13 MARCH 2009 (13.03.2009)		Date of mailing of the international search report 13 MARCH 2009 (13.03.2009)
Name and mailing address of the ISA/KR  Korean Intellectual Property Office Government Complex-Daejeon, 139 Seonsa-ro, Seo-gu, Daejeon 302-701, Republic of Korea Facsimile No. 82-42-472-7140		Authorized officer LEE Chang Ho Telephone No. 82-42-481-8435 

INTERNATIONAL SEARCH REPORT

Information on patent family members

International application No.

PCT/US2008/088509

Patent document cited in search report	Publication date	Patent family member(s)	Publication date
US 5824908 A	20.10.1998	US 5489361 US 5573624 A	06.02.1996 12.11.1996
US 5591913 A	07.01.1997	AT 209348 T AU 2438095 A CA 2190137 A1 CA 2190137 C DE 69524084 D1 DE 69524084 T2 EP 0759166 B1 JP 10-505408 T JP 10-505408 WO 95-31719 A1	15.12.2001 05.12.1995 23.11.1995 04.01.2005 03.01.2002 04.07.2002 21.11.2001 26.05.1998 26.05.1998 23.11.1995
US 4487072 A	11.12.1984	None	
US 5777891 A	07.07.1998	AU 1994892 A WO 92-19963 A1	21.12.1992 12.11.1992