

(19) **DANMARK**

(10) **DK/EP 3091875 T3**



Patent- og
Varemærkestyrelsen

(12) **Oversættelse af
europæisk patentskrift**

-
- (51) Int.Cl.: **A 47 C 3/20 (2006.01)**
- (45) Oversættelsen bekendtgjort den: **2019-10-14**
- (80) Dato for Den Europæiske Patentmyndigheds bekendtgørelse om meddelelse af patentet: **2019-07-17**
- (86) Europæisk ansøgning nr.: **15734964.8**
- (86) Europæisk indleveringsdag: **2015-01-11**
- (87) Den europæiske ansøgnings publiceringsdag: **2016-11-16**
- (86) International ansøgning nr.: **IB2015050203**
- (87) Internationalt publikationsnr.: **WO2015104686**
- (30) Prioritet: **2014-01-12 DE 202014000079 U**
- (84) Designerede stater: **AL AT BE BG CH CY CZ DE DK EE ES FI FR GB GR HR HU IE IS IT LI LT LU LV MC MK MT NL NO PL PT RO RS SE SI SK SM TR**
- (73) Patenthaver: **Inventor Group GmbH, Sihleggstrasse 23, 8832 Wollerau, Schweiz**
- (72) Opfinder: **WALSER, Thomas, Schulstrasse 7, CH-8280 Kreuzlingen, Schweiz**
- (74) Fuldmægtig i Danmark: **RWS Group, Europa House, Chiltern Park, Chiltern Hill, Chalfont St Peter, Bucks SL9 9FG, Storbritannien**
- (54) Benævnelse: **VIPBAR TABURET**
- (56) Fremdragne publikationer:
US-A- 513 584
US-A- 3 295 621
US-A- 3 312 437
US-A- 4 099 771
US-A- 4 130 263
US-A- 5 338 097
US-A- 5 746 481
US-A1- 2011 221 255
US-A1- 2013 334 846
US-B1- 6 644 742
US-S1- D 565 313

DESCRIPTION

TECHNICAL FIELD

[0001] The present invention generally relates to an article of furniture, and more particularly, to a tiltable stool or chair which self-adjusts to the weight of a user.

BACKGROUND

[0002] Articles of furniture such as stools or chairs which allow a user to rock forward, backward and sideways are generally known. A tiltable stool is typically configured to be used on a generally horizontal surface such as a floor. The stool comprises a top section providing seat and a base section comprising a rounded bottom surface configured to support the stool on the floor.

[0003] The base section may be a weighted base which has a downwardly convex lateral surface area to support the stool upon contacting the floor when the stool is tilted out of its normal upright position. In that normal position the stool rests on the floor with a flat or concave area of its base. The weighting of the base is so chosen that the center of gravity of the stool comes to lie inwardly of the perimeter of the central contact area in its tilted state. The support areas may be contiguous, thus forming part of a continuous annular surface, or may be peripherally spaced apart, as by being individually disposed on three or more legs projecting generally radially from the base. Such stools are generally described in US patent US 3312437 and in US patent application publication US 2013/0320727.

[0004] The conventional stools typically assume an upright normal position when unoccupied. The upright position is obtained by a resetting force which acts on the stool when tilted out of its normal upright position. The resetting force is caused by coordinating the center of gravity of the stool with the fixed shape of its base such that the center of gravity assumes its lowest position when the stool is upright. Typically, the resetting force is selected based on a desired characteristic of an unoccupied stool.

[0005] The rounded base of conventional stools have several disadvantages: They may cause noise when the stool is tilted, they require a relatively large and heavy base. The base may slide or roll away due to a small contact surface with the floor, and the stool generally provides insufficient support for a user when tilting out of the upright position, making it undesirable or even dangerous in particular for elderly users.

[0006] Attempts have been made to address the inherent disadvantages of a fixedly formed rounded base by using an inflatable base. An exemplary seating arrangement having an inflatable rubber ring is disclosed in US Patent 6,644,742. The inflatable base requires

occasional reinflation, which is not practical. It may also be prone to outgassing and cause an undesirable odor. A seat adapted to be mounted on a vehicle tire is disclosed in US 4,099,771 A1. The seat comprises a seat member, a seat base plate, a sleeve and a rod assembly, and a nut and bolt assembly. A furniture construction wherein articles of furniture are formed from discarded tires is disclosed in US 5,338,097 A1.

[0007] Also, bases made of foam have been proposed, but those do not address the lack of support for a user to maintain a generally upright seating position and do not adjust to a user's weight.

SUMMARY

[0008] An improved tiltable stool provides soft and comfortable dynamic seating without jeopardizing safety and stability. The stool is intended to be used while keeping both of a user's feet on the ground. When tilted out of a normal position the stool provides a stabilizing force which aides in maintaining a stable seating position. The stabilizing force of the stool increases approximately exponentially with the tilt angle of the stool out of the normal, typically upright, position. The stabilizing force also increases with the weight of a user. At a given tilt angle the stabilizing force increases approximately linearly with the weight of the user, thus making the stool self-adjust to the user's weight. The improved stool provides a similar seating experience for both light and heavy users: All users can easily tilt out of the normal position, while experiencing a stabilizing force with increasing tilt angle that corresponds to the user's weight. The improved tiltable stool provides dynamic seating flexibility similar to that of an exercise ball, but eliminates the inherent instability of sitting on a ball. Exercise balls have been associated with severe injuries when users have lost their balanced and fallen over backward. When the stool is unoccupied the stabilizing force is small and affected only by the weight of the stool, but sufficient to return a tilted stool into a normal position.

[0009] The improved stool comprises a seat, a body structure, and a base. The base comprises an annular elastic base member having a downwardly convex outer surface and a downwardly concave inner surface. The annular elastic base member is held in a base structure. The body structure extends between the seat and the base. Deformation of the annular elastic base causes a stabilizing force which pushes the tiltable stool towards a normal position when the tiltable stool or chair is tilted out of the normal position. An upper section of the annular elastic base is substantially cylindrical and firmly connected to the base structure. The downwardly convex outer surface of a lower section of the annular elastic base member rests on the floor. When the stool is upright a contact area between the annular elastic base member and the floor is substantially ring-shaped, and grows outwardly with an increasing weight placed on the seat.

[0010] According to one aspect of the invention, the annular elastic base member has a tapered cross-sectional shape with downwardly decreasing thickness. Typically, the normal position of the stool is upright. When the stool is upright the outer surface of an upper section

of the annular elastic base member is substantially vertical. However, the normal position may also be selected such that the stool is biased out of the upright position.

[0011] A tongue-and-groove connection may be used to connect the annular elastic base member to the base structure. A circular tongue at the upper end of the annular elastic base member engages a corresponding circular groove of the base structure. The annular elastic base may be press-fitted, glued, welded, or mechanically fixed to the base structure. In particular, an electrically conductive disc may be disposed within the circular groove of the base structure. The annular elastic base member may be welded to the base structure by applying an electric current through the electrically conductive disc. Alternatively, the tongue of the annular elastic base may be inserted into the circular groove of the base structure by cooling the annular elastic base to reduce the width of the circular tongue.

[0012] The annular elastic base may be made of various elastic materials, and is preferably made of plastic, which may be reinforced by glass fibers. In particular, the annular elastic base may be made of thermoplastic polyurethane (TPU).

[0013] According to another aspect of the invention the stool comprises an annular elastic base having an outwardly convex, substantially "j"-shaped cross section. Deformation of the annular elastic base affects a stabilizing force which increases with a tilt angle between a tilted seating position and the upright position. The stabilizing force increases approximately exponentially with the tilt angle. The stabilizing force increases, preferably linearly, with a weight that is applied to the seat.

[0014] According to still another aspect of the invention the annular elastic base has a substantially "o"-shaped cross section. The annular elastic base may then comprise a pressurized cavity between an outer wall and an inner wall.

BRIEF DESCRIPTION OF THE DRAWINGS

[0015]

FIG. 1 is a perspective top view of an exemplary tiltable stool.

FIG. 2 is a perspective bottom view of the stool as in FIG. 1.

FIG.3 is a cross sectional view of an exemplary tiltable stool, showing the stool in a tilted position.

FIG. 4 is a detailed cross sectional view of an exemplary annular elastic base under various loads.

FIG. 5 shows diagrams illustrating the relationship between load and deformation of the annular elastic base and between tilt angle and stabilizing force.

FIG. 6 is a cross sectional view of an alternative profile of an annular elastic base under two selected loads.

FIG. 7 shows a "j" profile of an annular elastic base under various loads.

FIG. 8 shows an "o" profile of an annular elastic base under various loads.

FIG. 9 shows exemplary contact areas of the annular elastic base with the floor under various loads.

FIG. 10 is a cross section view through an exemplary annular elastic base in a normal (upright) position and in a tilted position.

FIG. 11 is a perspective bottom view of an exemplary annular elastic base with additional ridges.

FIG. 12 is a perspective bottom view of an exemplary annular elastic base in a tilted position.

DETAILED DESCRIPTION

[0016] Referring to FIGS 1, 2 and 3, a tiltable stool **1** comprises a seat **2**, a base **3**, and an elongated body structure **4** between the base **3** and the seat **2**. The stool **1** may comprise a height adjustment mechanism including an adjustment lever **7** to adjust the length of the body structure **4**. The body structure **4** may comprise a pillar assembly and defines a vertical axis **13** of the stool **1**.

[0017] The base **3** may comprising a base structure **6** connected to an annular elastic base member **5**. The annular elastic base member **5** is configured to rest on the floor **14**. The stool **1** is tiltable in any direction by deforming the annular elastic base member **5**. When a tilting force is applied to the seat, the seat is moved from a normal position into a dynamic seating position. Typically, the normal position is upright. In the upright position the vertical axis **13** of the stool **1** is perpendicular to the floor **14**. In response to a tilting force the annular elastic base member **5** is deformed, and the vertical axis **13** of the stool **1** is tilted by a tilt angle α out of the normal position. The annular elastic base member **5** may be rotationally symmetrical and extend around a central opening

[0018] FIG. 3 shows a cross section of the stool **1** in a tilted seating position. Here, the stool **1** is tilted to the right by a tilt angle α out of the upright position. The annular elastic base member **5** is deformed and the height of the annular elastic base varies. As shown, the annular elastic base member **5** is compressed in the direction of the tilt (right side of FIG. 3) and expanded opposite the direction of the tilt (left side of FIG. 3). Compression of the annular elastic base member **5** causes a stabilizing force F_s at the seat **2** which counteracts the tilting force. In a stable tilted position the weight of the user F_w is countered by an axial force F_a in

the direction of the vertical axis **13** and the stabilizing force F_s which is perpendicular to the axial force F_a .

[0019] The annular elastic base member **5** extends from a substantially circular upper end **38** to a lower end **39** around an opening. The diameter of the annular elastic base member **5** at the upper end **38** is larger than the diameter of the annular elastic base member **5** at the lower end **39**. Beneficially, the diameter at the upper end **38** is between approximately 1.2 and 1.6 times that of the diameter at the lower end **39**. The annular elastic base member **5** has a downwardly convex outer surface **10** and a downwardly concave inner surface **11**. The outer surface **10** of the annular elastic base contacts the floor **14** at a contact area **15**. The contact area **15** extends at a distance around the vertical axis **13**. A tongue **36** may be formed at the upper end **38** of the annular elastic base member **5** which engages a corresponding groove **37** in the base structure **6** to firmly connect the annular elastic base member **5** to the base structure **6**.

[0020] FIG. 4 shows the deformation of an exemplary annular elastic base member **5** under various loads in more detail. When a first force F_1 of approximately 400N/m is applied, the annular elastic base member **5** has a first height h_1 and a first cross sectional shape **311**. The first force F_1 correlates to a person weighing about 40 kg sitting on a stool to which an annular elastic base member with a diameter of 320 mm is attached. As the stool is more heavily loaded, the annular elastic base member **5** is deformed. When loaded with a second force F_2 of approximately 800N/m, corresponding to a person with a weight of 80 kg sitting on the stool, the annular elastic base member assumes a second cross sectional shape **312**. The height of the annular elastic base is reduced by a first deformation d_2 to a second height h_2 . When further loaded with a third force F_3 of approximately 1200N/m, corresponding to a person with a weight of about 120kg sitting on the stool, the annular elastic base member **5** assumes a third cross sectional shape **313**. Under the third load F_3 the height of the annular elastic base is reduced by a second deformation d_3 to a third deformed height h_3 .

[0021] The relationship between deformation d and load F of an annular elastic base is generally shown in FIG. 5. The relationship **500** between deformation d and load F is non-linear. More specifically, with increasing deformation d the load F grows approximately exponentially. The non-linear relationship between load F and deformation d allows users of vastly different weight to use a stool equipped with the annular elastic base, without significantly affecting the overall height of the stool.

[0022] Tilting a stool by an angle α out of the normal position causes a stabilizing force opposite the direction of tilt. The relationship between tilt angle α and stabilizing force F_r is generally shown in curves **501**, **502** and **503** shown in FIG. 5. As illustrated, the stabilizing force is zero when the stool is in an upright position, allowing a user to easily tilt. The stabilizing force F_r increases with increasing tilt angle α as shown in curves **501**, **502** and **503**. The different curves show the stabilizing force for users of different weight. As shown, the first curve **501** illustrates the stabilizing force for a heavy user weighing 120 kg. The second curve **502** illustrates the stabilizing force for a medium user weighing 80 kg. The third curve **503** illustrates

the stabilizing force for a light user weighing 40 kg. At a given tilt angle α' the stabilizing force F_{r1} experience by the heavy user is larger than the stabilizing force F_{r2} experienced by the medium user, which in turn is larger than the stabilizing force F_{r3} experienced by the light user. This desired effect provides a similar seating experience for users of various weights. It provides additional stabilizing support for heavier users without impeding the ability of lighter users to reach the same tilt angle.

[0023] FIG. 6 shows an alternative cross sectional shape **601, 602** of the annular elastic base member **5** in an unloaded state and in a loaded state. The annular elastic base member **5** preferably has an inwardly curved cross sectional shape **601, 602**. The annular elastic base member **5** may be tapered, having a downwardly decreasing thickness. The thickness of the annular elastic base member **5** may decrease from a first thickness **t1** at an upper, substantially cylindrical section **325** of the annular elastic base member **5** to a lower thickness **t2** at a lower end section **326** of the annular elastic base member **5**. The tapered profile of the annular elastic base member **5** supports the desired load /deformation characteristic as shown in FIG. 5. Thinner portions of the annular elastic base member **5** close to its lower end **39** bend more easily than upper portions close to its upper end **38**.

[0024] The uneven thickness of the annular elastic base member **5** allows a stool equipped therewith to be used equally by a very light user, such as a child, and a heavy adult. In case of a child, only the lower, thinner, portions of the annular elastic base member **5** will bend. When used by an adult, the thicker, upper, portions of the annular elastic base member **5** will also bend. In both cases the user will experience a similar "feel" of the stool's stabilizing force.

[0025] Under extreme load the lower end **39** of the annular elastic base member **5** may bend through completely and come to rest against the base structure **6**. This limits the maximum deformation of and prevents damage to the annular elastic base member **5** when exposed to extreme loads.

[0026] The annular elastic base member **5** may be shaped outwardly convex and inwardly concave. The downwardly convex outer surface **10** and a downwardly concave inner surface **11** meet at the lower end **39** of the annular elastic base member. The lower end **39** of the annular elastic base member may extend into a stiffening ring **40** as shown in FIG. 4. The stiffening ring **40** at the lower end **39** helps stabilizes the annular elastic base member **5** at the contact area **15**. The stiffening ring **40** protects the lower end **39** from kinking when the stool **1** is loaded and/or tilted out of its normal position. The stiffening ring **40** is preferably an integral component of the annular elastic base member **5**.

[0027] To prevent kinking, the lower end **39** of the annular elastic base member **5** may also be bent upwardly, such that the contact area **15** between the annular elastic base member **5** and the floor is below and radially outward of the lower end **39** of the annular elastic base member **5**.

[0028] When a stiffening ring **40** is used to strengthen the lower end **39** of the annular elastic base member **5**, the unloaded annular elastic base **5** may contact the floor at the stiffening ring **40** as is shown in FIG. 4. This arrangement has been found beneficial when working with relatively thick material. When using relatively thinner cross sectional shapes it has been found beneficial to provide the unloaded contact area **15** of the annular elastic base **5** radially outwardly and below the stiffening ring **40** as is shown in FIG. 10.

[0029] Opposite the lower end **39** an upper end **38** of the annular elastic base member **5** may be formed as a tongue **36** which engages a corresponding groove **37** in the base structure **6**. The tongue **36** may be slightly wider than the groove **37** and during assembly the tongue **36** may be press-fitted into the groove **37** with the help of a tool that secures the annular elastic base member **5** during insertion into the base structure **6**. The tongue may be further secured with self-tapping screws. As shown in FIG. 11, mounting holes **12** may be provided and are preferably circumferentially spaced at the base structure **6** to secure radially outwardly directed screws into an upper portion of the inner surface **11** of the annular elastic base member **5**.

[0030] Alternatively, the tongue **36** of the annular elastic base member **5** may be assembled to the groove **37** of the base structure **6** by gluing or welding. In particular, the annular elastic base member **5** may be ultrasonically welded to the base structure **6**. Welding may also be achieved by inserting an electrically conductive disc into the groove **37** or by molding an electrically conductive element into the tongue **36**. An electric current may then be applied to the electrically conductive disc in order to cause resistive heating. The electric heating causes the surface of the tongue **36** to meld and weld to groove **37**.

[0031] Yet another assembly option is to cool the annular elastic base member **5** to a temperature significantly below room temperature, causing the tongue **36** to shrink. Cooling may for example be affected by directing a cold gas onto the tongue **36** just before insertion into the groove **37**. The groove **37** may be dimensioned such that the cooled tongue **36** can be easily inserted thereto, but is firmly held within the groove **37** once the tongue **36** warms back up to room temperature, expanding within the groove **37**. Experiments have shown that load on the stool **1** reinforces the tongue-and-groove connection between the annular elastic base member **5** and the base structure **6**, so that reinforcement of the connection by welding or gluing is not critical and may not be necessary at all.

[0032] The cross-sectional profile and the material of the annular elastic base member **5** are coordinated to provide a desired seating experience. The annular elastic base member **5** may be made of thermoplastic polyurethane (TPU), rubber, thermoplastic polyolefin (TPO), fiberglass enforced polyamide (PA) or fiberglass enforced polyurethane (PU). The selection of material requires a trade-off decision between cost and functionality. Experiments including durability tests have shown, that a thermoplastic polyurethane with 90 Shore hardness provides the required robustness at an affordable price. An annular elastic base member **5** made of softer TPU with 75 Shore hardness would require about twice the amount of material as one made of TPU with 90 Shore hardness.

[0033] The following configuration of the annular elastic base member **5** has been found to be particularly beneficial for users having a weight between 40 kg and 150 kg, which is a typical market requirement:

- Material: TPU
- Mass: 600 grams
- Hardness: 90 Shore
- Diameter at the upper end **38**: 333 mm
- Diameter at the lower end **39**: 245 mm
- Height **h1** without load: 56mm (including the tongue **36**)
- Height without load: 48mm (not including tongue **36**)
- Tongue **36** dimensions: 8x8 mm
- Thickness **t1** at an upper section **325**: 13 mm
- Thickness **t2** at a lower section **326**: 2 mm
- Thickness (diameter) of the stiffening ring **40**: 8 mm

[0034] An alternative substantially "j"-shaped cross-sectional profile **701, 702, 703** of an annular elastic base member **5** under three different loads is shown in FIG. 7. This profile may be used in combination with harder materials such as fiber-enforced polyamide or polypropylene. The shown "j"-shaped profile **701, 702, 703** has a more even thickness and consequently bends more readily compared to the tapered profile **601** shown in FIG. 6. While this is generally not preferred as it increases the risk of kinking, the "j"-shaped profile **701, 702, 703** may be manufactured more cost effectively, and may hence be a viable alternative for cost sensitive products.

[0035] Yet another alternative cross-sectional profile **801, 802, 803** is substantially "o"-shaped as shown in FIG. 8. An annular elastic base member **5** having a substantially "o"-shaped cross-sectional profile **801** may be manufactured by extrusion, and thus be an alternative to molded profiles. Alternatively, the annular elastic base member **5** having a substantially "o"-shaped cross-sectional profile **801** may be formed by rotational molding or by blow molding. The substantially "o"-shaped profile **801** may comprise a cavity **804** which may be filled with air or another gas and may be pressurized.

[0036] FIG. 9 illustrates the shape of the contact area **15** of the annular elastic base **5** with the floor **14** under various loads. An unloaded stool may have a contact area **15** that assumes a first circular shape **331**. For reference, the position **335** of the upper end **38** of the annular elastic base member **5** is shown in a dashed line in FIG.9. When the stool is symmetrically loaded and upright the contact area grows outwardly but remains circular. Consequently, the contact area **15** may assume a second circular shape **332** that has larger diameter than the first circular shape **331** when additional weight is placed on the stool. When tilted, the contact area may assume a substantially oval shape **333**. As shown, the substantially oval shaped contact area **333** has a longer inner lever l_i than outer lever l_o . The inner level l_i is measured from the intersection of the vertical axis **13** with the floor **14** to the contact area in the direction

of the tilt. The outer lever l_o is measured from the intersection of the vertical axis **13** with the floor **14** to the contact area in the direction opposite the tilt. The contact area **15** remains within the confines of the position **335** of the upper end **38** of the annular elastic base member **5** under all loads, and whether loaded symmetrically or asymmetrically.

[0037] When the an annular elastic base member **5** is used with additional circumferentially spaced radially extending ridges **42**, the contact area **15** consists of a plurality of circumferentially spaced radially extending surfaces **336** that are arranged in an approximately circular shape **331**, **332** or approximately oval shape **333** as explained above.

[0038] The stool may be tilted beyond its dynamic seating envelope of about 10 degrees. In that case the substantially oval shaped contact area **333** opens up at the inner end and eventually assumes an approximately crescent-shape **334**. When tilting the stool beyond its dynamic seating envelope a user will remain a stable position by applying force to his legs. Advantageously, the so tilted stool does not have a tendency to roll sideways. Further, the elasticity of the annular elastic base provides good friction on the floor and thus prevents the stool from sliding backward.

[0039] When in its upright position the annular elastic base member **5** has a substantially ring-shaped, circular, contact area **15** with the floor. Increasing deformation of the annular elastic base member **5** causes the diameter of this ring-shaped contact area **15** to grow outwardly. This increases the effective lever arm **1** of the annular elastic base member **5**. When the stool **1** is tilted out of its normal position the contact area **15** changes from a circular shape toward an approximately oval shape. Beneficially, the effective inner lever l_i in the direction of the tilt is growing larger, while the effective outer lever l_o opposite the direction of tilt is getting smaller. This effect amplifies the stabilizing force of the stool and contributes to its stability.

[0040] The shape of the contact area as shown in Fig. 9 is further illustrated in the cross sectional view of Fig. 10. Here, the annular elastic base **5** is shown in a symmetrically loaded or upright position **8** and in a tilted position **9**. In the tilted position **9** the annular elastic base member **5** is tilted by an angle α out of the upright position **8**. The comparison of the symmetrically loaded upright position **8** with the tilted position **9** shows the relative change of the inner lever l_i and the outer lever l_o . As shown, the inner lever l_i grows in the direction of the tilt and the outer lever l_o becomes shorter in the direction opposite the tilt.

[0041] The maximum elastic deformation of the annular elastic base member **5** may allow spring-loaded tilt of the stool of up to about 10 degrees and be associated with the equivalent of a symmetrical load of 200 kg. A user may tilt the stool beyond its dynamic seating envelope up to about 45 degree. This is achieved by lifting the backward portion of the annular elastic base member **5** into the air. Tilting the stool up to about 45 degrees allows a user to conveniently pick up articles from the floor. The shape of the annular elastic base member as described before provides a relatively smooth and seamless transition from dynamic deformation (up to approximately 10 degrees) to lifting the backward portion of the base into

the air (between approximately 10 degrees and 45 degrees).

[0042] FIG. 11 shows an annular elastic base member **5** with additional circumferentially spaced radially extending ridges **42** at the contact area of the annular elastic base with the floor. The radially extending ridges **42** have been found to prevent noise that might otherwise be caused by deformation of the annular elastic base member **5**. Noise may stem from vibrations that may be caused when the annular elastic base member **5** deforms while a user tilts the associated stool. The radially extending ridges **42** may also prevent a vacuum from forming under a stool equipped with the annular elastic base member **5**. This is particularly relevant if the annular elastic base member **5** and the base structure **6** form an upwardly sealed surface. In that case, the annular elastic base member **5** and the base structure **6** could act a large suction cup, which must be prevented. Prevention is achieved by the ridges **42** which segment the contact area of the annular elastic base **5** with the floor **14** and allow air to pass through air channels between the ridges **42**. Instead of ridges **42**, grooves (not shown) may be applied to the annular elastic base member **5** in an equivalent circumferentially spaced and radially extending arrangement to provide the desired air channels. FIG. 11 shows a configuration with 44 ridges. Alternative configurations may choose to use more or fewer ridges, for example between 20 and 80 ridges.

[0043] Fig. 12 shows a deformed annular elastic base member **5** under extreme load. The lower end **39** of the annular elastic base member **5** here bends through completely and comes to rest against a stop surface **320** of the base structure **6**. This limits the maximum deformation and thereby prevents damage of the annular elastic base member **5** when exposed to extreme loads. The extremely loaded stool remains slightly elastic based on compression of the material of the annular elastic base **5**. Damage to the floor is prevented as the base structure **6** does not contact the floor even under extreme load.

[0044] While the present invention has been described with reference to exemplary embodiments, it will be readily apparent to those skilled in the art that the invention is not limited to the disclosed or illustrated embodiments but, on the contrary, is intended to cover numerous other modifications, substitutions, variations and broad equivalent arrangements that are included within the scope of the following claims. For example, while this specification and the claims refer to a stool, it should be understood that the invention can equally be applied to a chair or other tiltable article of furniture.

Alternative Examples

[0045] A tiltable stool, comprising:

a seat;

an annular elastic base member; and

an elongated body structure extending between the seat and the base.

[0046] The tiltable stool as above, wherein the annular elastic base is rotationally symmetrical.

[0047] The tiltable stool as above, wherein the annular elastic base member comprises a downwardly convex outer surface and a downwardly concave inner surface extending around a central opening.

[0048] The tiltable stool as above, further comprising a height adjustment mechanism.

[0049] The tiltable stool as above, wherein the elongated body structure comprises a pillar assembly and defines a vertical axis of the stool.

[0050] The tiltable stool as above, wherein the annular elastic base member is an integral molded component.

[0051] The tiltable stool as above, wherein the annular elastic base member rests on the floor.

[0052] The stool as above, wherein the stool can be tilted in any direction by deforming the annular elastic base.

[0053] The stool as above, wherein the stool can be tilted in any direction by deforming the annular elastic base within a dynamic seating enveloped of approximately 10 degree tilt.

[0054] The stool as above, wherein the stool can be tilted beyond the dynamic seating envelope by lifting a backward portion of the annular elastic base into the air.

[0055] The stool as above, wherein the stool wherein the stool has an upright normal position.

[0056] The stool as above, wherein deformation and/or compression of the annular elastic base member causes a stabilizing force.

[0057] The stool as above, wherein the stabilizing force increases with the weight of a user.

[0058] The stool as above, wherein the stabilizing force increases with the tilt angle of the stool.

[0059] The stool as above, wherein the stabilizing force increases approximately exponentially with the tilt angle of the stool.

[0060] The stool as above, wherein the height of the annular elastic base member decreases in the direction of tilt when the stool is tilted.

[0061] The stool as above, wherein the height of the annular elastic base member increases in the direction opposite tilt when the stool is tilted.

[0062] The stool as above, wherein a tongue is formed at an upper end of the annular elastic base member.

[0063] The stool as above, wherein the tongue engages a corresponding groove in the base.

[0064] The stool as above, wherein the tongue has a height of approximately 8 mm and a thickness of approximately 8 mm.

[0065] The stool as above, wherein the tongue is press-fitted into the groove.

[0066] The stool as above, wherein the stool is configured to support a user having a weight between 40 kg and 150 kg.

[0067] The stool as above, wherein the annular elastic base is configured to support a load between approximately 400 N/m and 1500 N/m.

[0068] The stool as above, wherein the annular elastic base member has an inwardly curved cross section.

[0069] The stool as above, wherein the annular elastic base member is tapered having a downwardly decreasing thickness.

[0070] The stool as above, wherein the annular elastic base member is tapered having a downwardly decreasing thickness.

[0071] The stool as above, wherein the annular elastic base member is made of thermoplastic polyurethane.

[0072] The stool as above, wherein the annular elastic base member has a mass of approximately 600 grams.

[0073] The stool as above, wherein the annular elastic base member has a hardness of approximately 90 Shore.

[0074] The stool as above, wherein the annular elastic base member has a diameter at the upper end of approximately 333 mm.

[0075] The stool as above, wherein the annular elastic base member has a diameter at the lower end of approximately 245 mm.

[0076] The stool as above, wherein the annular elastic base member has a diameter at the

upper end that is approximately 1.4 times its diameter at the lower end.

[0077] The stool as above, wherein the annular elastic base member has a diameter at the upper end that is between 1.2 and 1.6 times its diameter at the lower end.

[0078] The stool as above, wherein the annular elastic base member has height **h1** without load of approximately 56mm including a tongue.

[0079] The stool as above, wherein the annular elastic base member has height without load of approximately 48mm, not including a tongue.

[0080] The stool as above, wherein the annular elastic base member has a thickness **t1** at its upper end of approximately 13 mm.

[0081] The stool as above, wherein the annular elastic base member has a thickness **t2** at its lower end of about 2 mm.

[0082] The stool as above, wherein a lower end of the annular elastic base member touches a stop surface when fully deformed under heavy load.

[0083] The stool as above, wherein deformation of the annular elastic base is limited by a stop surface in the base which supports the lower end of the annular elastic base under heavy loads.

[0084] The stool as above, wherein the annular elastic base is secured to the base by screws.

[0085] The stool as above, wherein the annular elastic base is secured to the base by self-tapping screws.

[0086] The stools as above, wherein mounting holes are provided and circumferentially spaced at the base structure to secure radially outwardly directed screws into an upper portion of the inner surface of the annular elastic base member.

[0087] The stools as above, wherein the lower end of the annular elastic base member is bent upwardly, such that the contact area between the annular elastic base member and the floor is below and radially outward of the lower end of the annular elastic base member.

[0088] The stool as above, wherein a stiffening ring is provided at the lower end of the annular elastic base member.

[0089] The stool as above, wherein the stiffening ring has a diameter of approximately 8 mm.

[0090] The stool as above, wherein the annular elastic base member contacts the floor at the stiffening ring when the stool is unoccupied.

[0091] The stool as above, wherein the annular elastic base member contacts the floor radially outwardly and axially below the stiffening ring when the stool is unoccupied.

[0092] The stool as above, wherein the annular elastic base member has an approximately circular contact area with the floor when the stool is upright.

[0093] The stool as above, wherein the radius of the approximately circular contact area with the floor increases as weight is placed onto the stool.

[0094] The stool as above, wherein the contact area of the annular elastic base member with the floor is approximately oval when the stool is tilted.

[0095] The stool as above in a tilted position, wherein an outer lever l_o measured from the intersection of the vertical axis with the floor to the contact area in the direction opposite the tilt is shorter than an inner lever l_i measured from the intersection of the vertical axis with the floor to the contact area in the direction of the tilt.

[0096] The stool as above, further comprising circumferentially spaced radially extending ridges at the contact area of the annular elastic base with the floor.

[0097] The stool as above, comprising between 20 and 80 ridges.

[0098] The stool as above, further comprising circumferentially spaced radially extending grooves at the contact area of the annular elastic base with the floor.

[0099] The stool as above, comprising between 20 and 80 grooves.

REFERENCES CITED IN THE DESCRIPTION

This list of references cited by the applicant is for the reader's convenience only. It does not form part of the European patent document. Even though great care has been taken in compiling the references, errors or omissions cannot be excluded and the EPO disclaims all liability in this regard.

Patent documents cited in the description

- [US3312437A](#) **[0003]**
- [US20130320727A](#) **[0003]**
- [US6644742B](#) **[0006]**

- US4099771A1 [0006]
- US5338097A1 [0006]

Patentkrav

1. Vipbar taburet (1), der omfatter:
et sæde (2)
5 en bund (3), der omfatter et ringformet elastisk bundelement (5)
en kropsstruktur (4), der strækker sig mellem sædet (2) og bunden (3),
hvor det ringformede elastiske bundelement (5) har en konisk
10 tværsnitsform med nedad aftagende tykkelse, og
hvor deformation af det ringformede elastiske bundelement (5) medfører en stabiliserende kraft, der skubber den vipbare taburet (1) mod en normal position, når den vipbare taburet (1) vipkes ud af den normale position, hvor
15 det elastiske bundelement (5) har en nedad konveks ydre overflade (10) og en nedad konkav indre overflade (11), kendetegnet ved, at
stabiliseringskraften (F_s) tiltager omtrent eksponentielt med vippevinklen (α).
20
2. Vipbar taburet (1) ifølge krav 1,
hvor bunden (3) desuden omfatter en bundstruktur (6), og
hvor en øvre sektion af det ringformede elastiske bundelement (5) i det væsentlige er cylindrisk og fast forbundet til
25 bundstrukturen (6).
3. Vipbar taburet (1) ifølge krav 1 eller 2, hvor en nedre ende af det ringformede elastiske bundelement (5) kommer i kontakt med bundstrukturen (6), når det ringformede elastiske
30 bundelement (5) er fuldstændigt deformeret.
4. Vipbar taburet (1) ifølge krav 1, 2 eller 3,
hvor den nedad konvekse ydre overflade (10) af en nedre sektion af det ringformede elastiske bundelement (5) hviler på
35 gulvet (14).
5. Vipbar taburet (1) ifølge krav 4,
hvor et kontaktområde (15) mellem det ringformede elastiske

bundelement (5) og gulvet (14) i det væsentlige er ringformet, og hvori kontaktområdet (15) vokser udad, når en vægt placeres på sædet.

5

6. Vipbar taburet (1) ifølge krav 1, hvori det ringformede elastiske bundelement (5) i sin øvre ende omfatter en cirkulær flig (36), der griber ind i en tilsvarende cirkulær not (37) i en bundstruktur (6).

10

7. Vipbar taburet (1) ifølge krav 6, hvori den cirkulære flig (36) prestilpasses i den tilsvarende cirkulære not (37).

8. Vipbar taburet (1), der omfatter:

15

et sæde (2)

en bund (3), der omfatter et rotationssymmetrisk ringformet elastisk bundelement (5), og

en aflang kropsstruktur (4), der strækker sig mellem sædet (2) og bunden (3),

20

hvori deformation af det ringformede elastiske bundelement (5) medfører en stabiliserende kraft, der skubber den vipbare taburet (1) mod en normal position, når den vipbare taburet (1) vipkes ud af den normale position, hvori

25

det elastiske bundelement (5) omfatter et udad konveks i det væsentlige "j"-formet tværsnit (701, 702, 703) eller et i det væsentlige o-formet tværsnit (801, 802, 803), som har en nedad konveks ydre overflade og en nedad konkav indre overflade, der strækker sig omkring en central åbning, kendetegnet ved, at stabiliseringskraften (F_s) tiltager omtrent eksponentielt med vippevinklen (α).

30

9. Vipbar taburet (1) ifølge krav 1 eller 8, hvori det ringformede elastiske bundelement (5) omfatter en flerhed af rundtgående spredte og radialt forløbende noter eller kanter (42) i et kontaktområde (15) med gulvet (14).

35

10. Vipbar taburet (1) ifølge et af kravene 1 til 9, hvori den vipbare taburet (1) har en i det væsentlige

opretstående position, når den ikke udsættes for en vippekraft, og

hvor i den vipbare taburet (1) kan vippes væk fra den opretstående position til en dynamisk siddeposition ved hjælp

5 af en vippekraft, og

hvor i deformation af det ringformede elastiske bundelement (5) medfører en stabiliserende kraft (F_S), der skubber den vipbare taburet (1) mod vippekraften fra den dynamiske siddeposition hen imod den opretstående position.

10

11. Vipbar taburet (1) ifølge et af kravene 1 til 10, hvor i stabiliseringskraften (F_S) tiltager med en hældningsvinkel (α) mellem den dynamiske siddeposition og den opretstående position.

15

12. Vipbar taburet (1) ifølge et af kravene 1 til 10, hvor i stabiliseringskraften (F_S) tiltager med en vægt, der påføres sædet (2).

20

13. Vipbar taburet ifølge et af kravene 1 til 10, hvor i det ringformede elastiske bundelement (5) er konisk med en nedad aftagende tykkelse på ca. 13 mm i en øvre ende og på ca. 2 mm i en nedre ende, og

25

hvor i det ringformede elastiske bundelement (5) er fremstillet af termoplastisk polyurethan med en hårdhed på ca. 90 Shore, og

hvor i den øverste ende af det ringformede elastiske bundelement (5) har en diameter på cirka 333 mm, og

hvor i den nedre ende af det ringformede elastiske bundelement (5) har en diameter på ca. 245 mm, og

30

hvor i en afstivningsring (40) med en tykkelse på ca. 8 mm er tilvejebragt i den nedre ende af det ringformede elastiske bundelement (5).

35

14. Vipbar taburet (1) ifølge et af kravene 1 til 13, hvor i det ringformede elastiske bundelement (5) har en diameter i den øvre ende, der er mellem 1,2 og 1,6 gange dens diameter ved den nedre ende, når den vipbare taburet er i en ubelastet

tilstand.

DRAWINGS

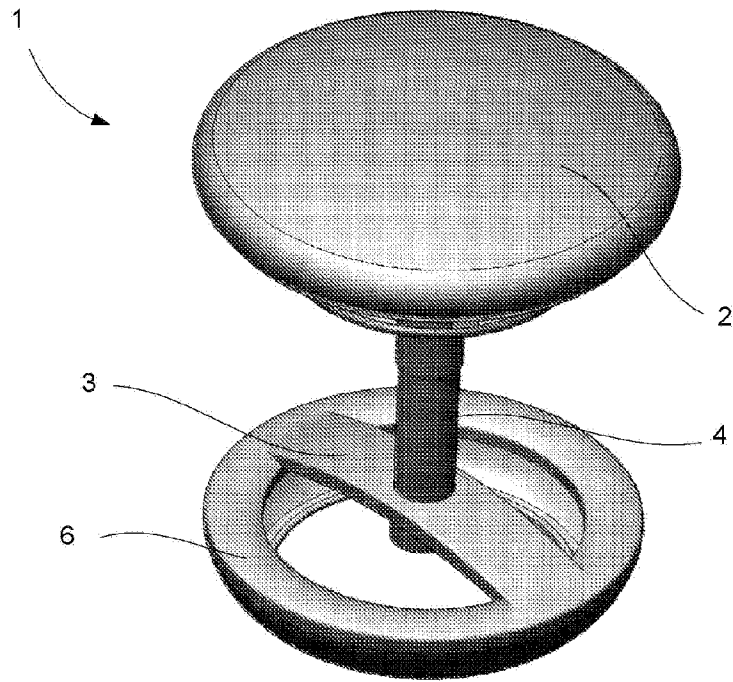

FIG. 1

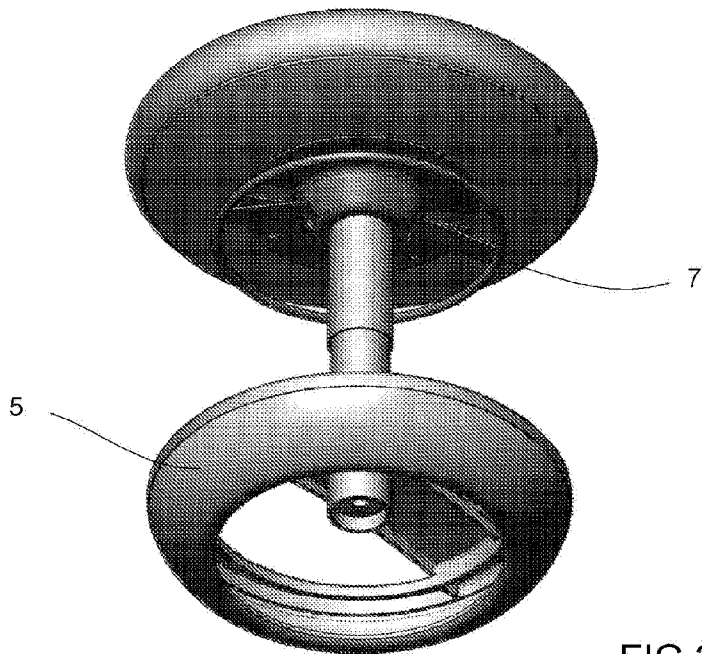

FIG. 2

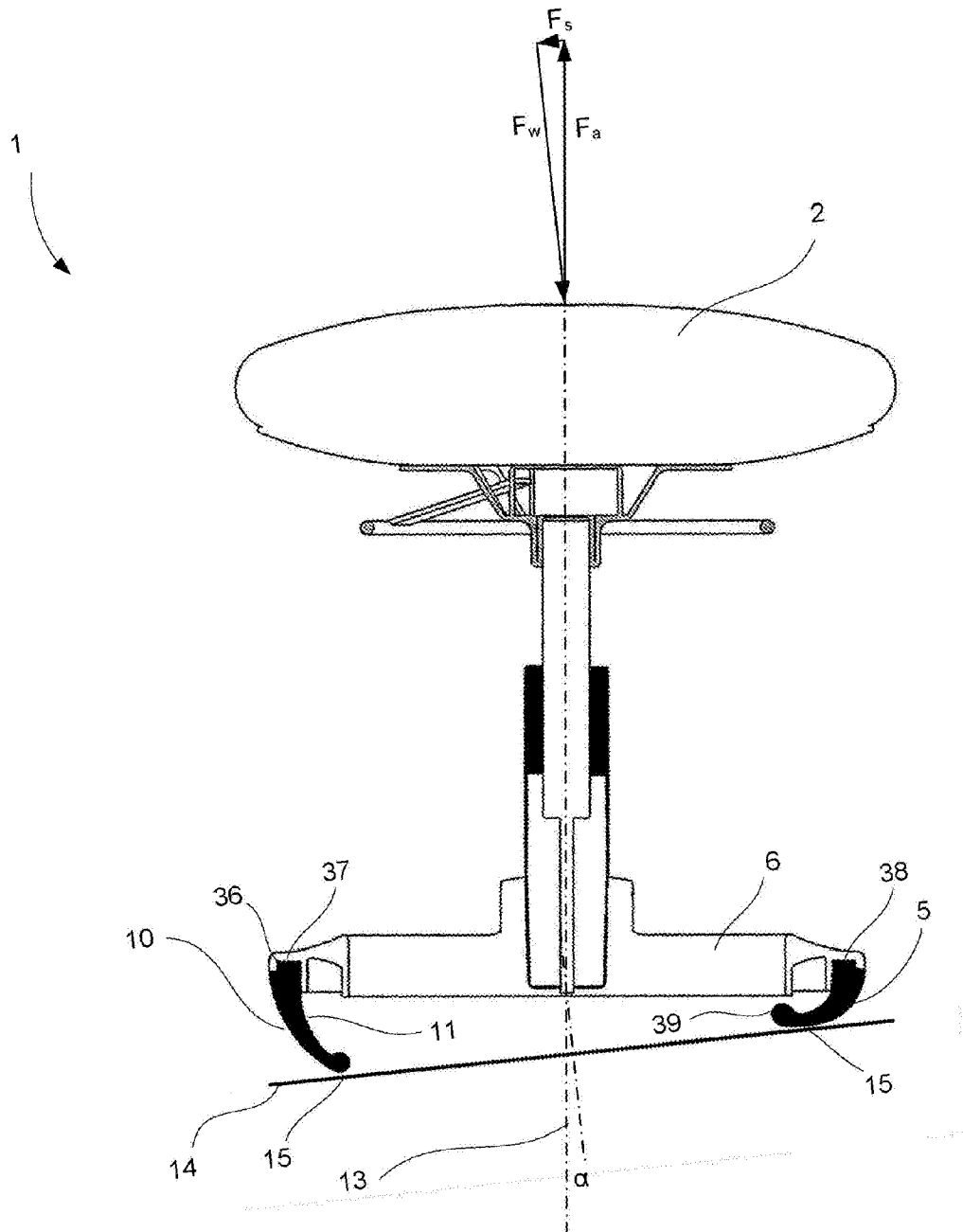

FIG.3

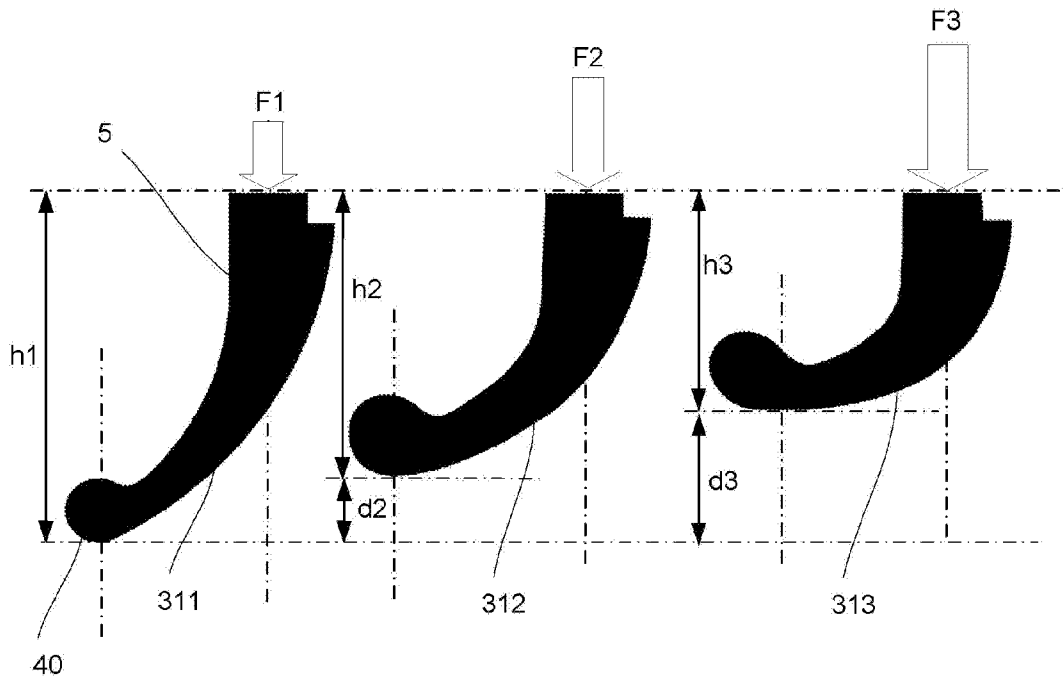

FIG. 4

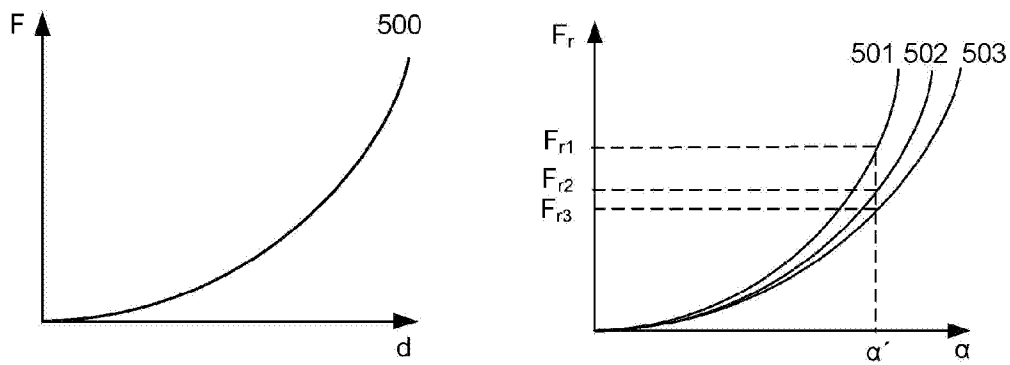

FIG. 5

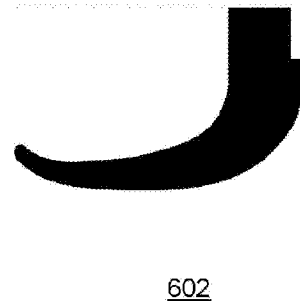
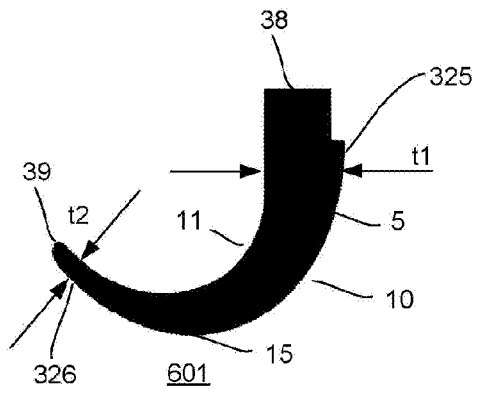
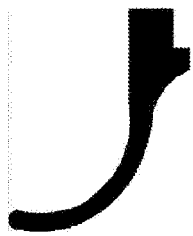

FIG. 6



701



702



703

FIG. 7

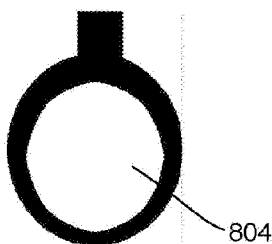

801

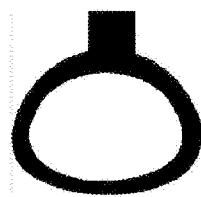

802



803

FIG. 8

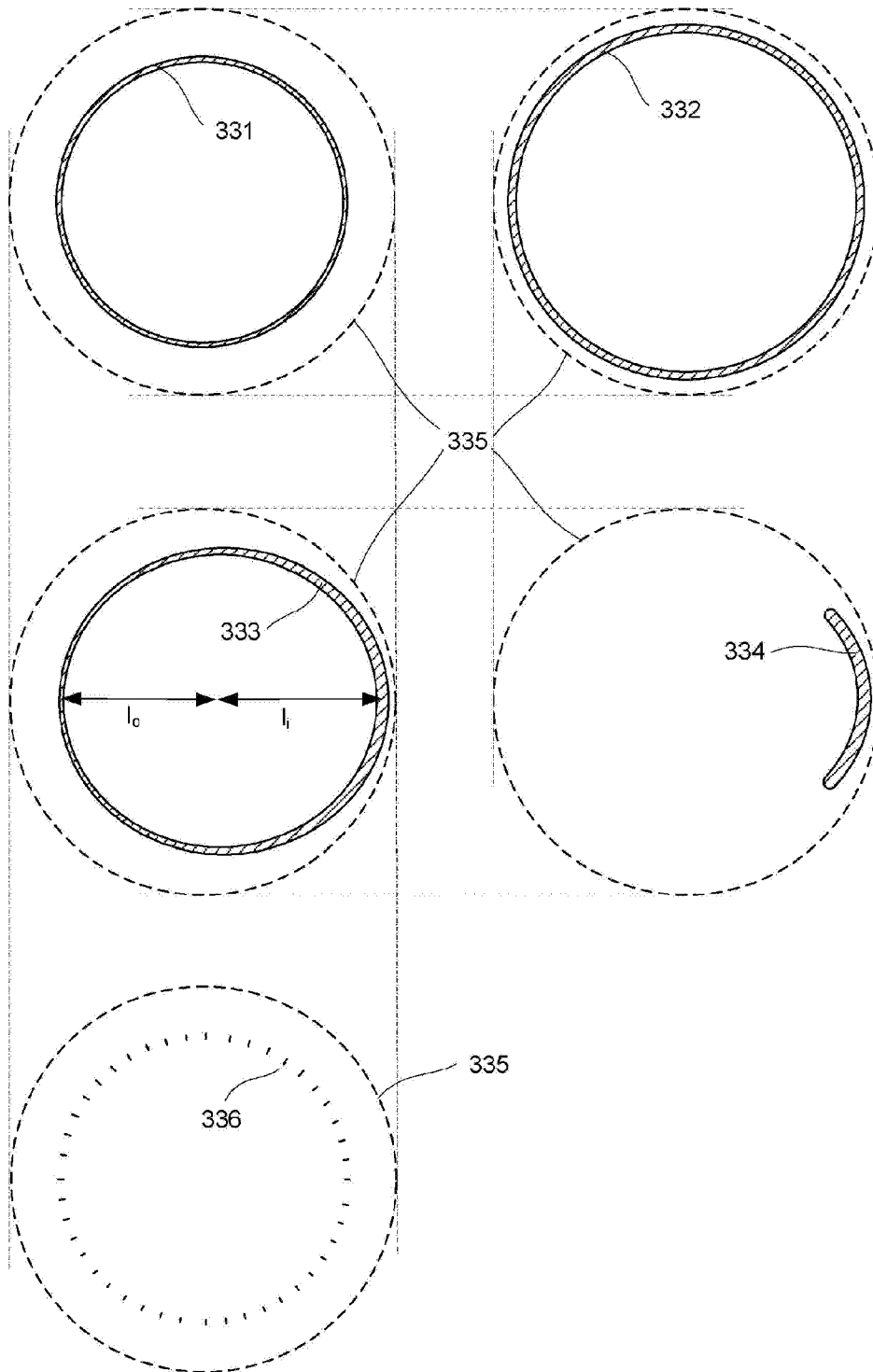

FIG.9

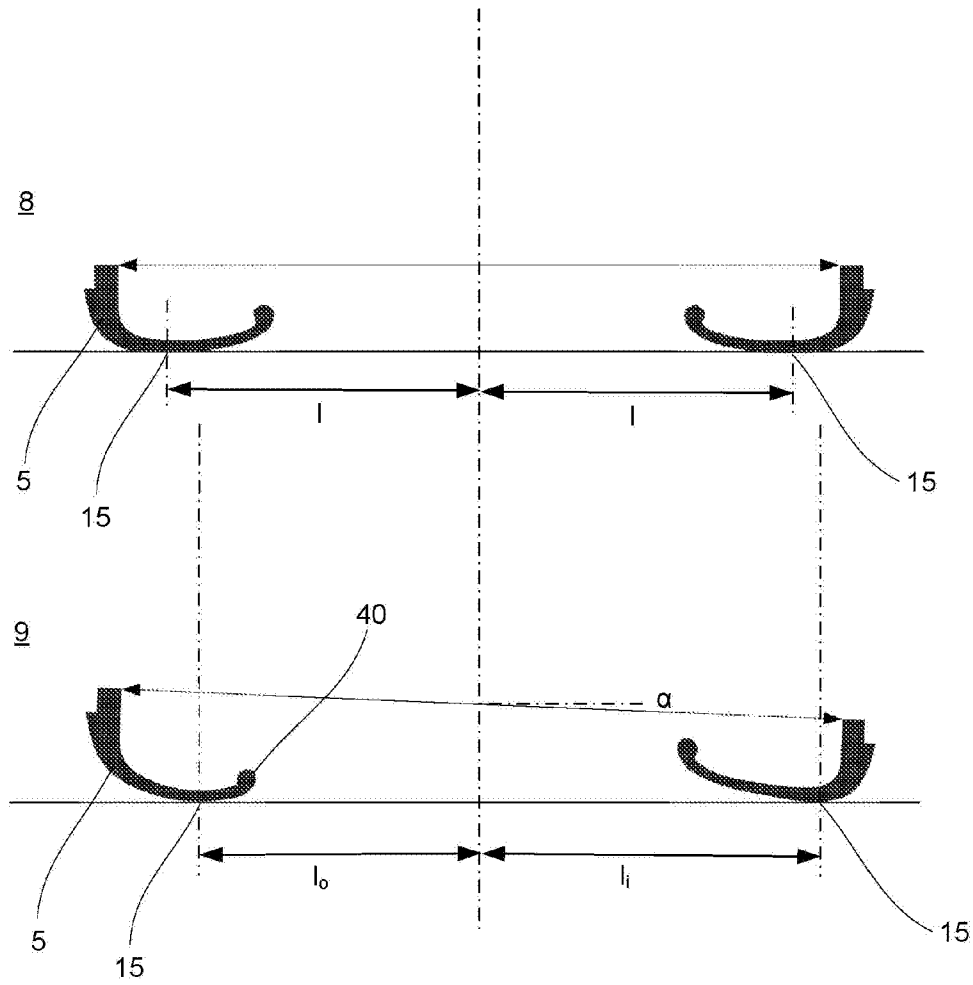

FIG.10

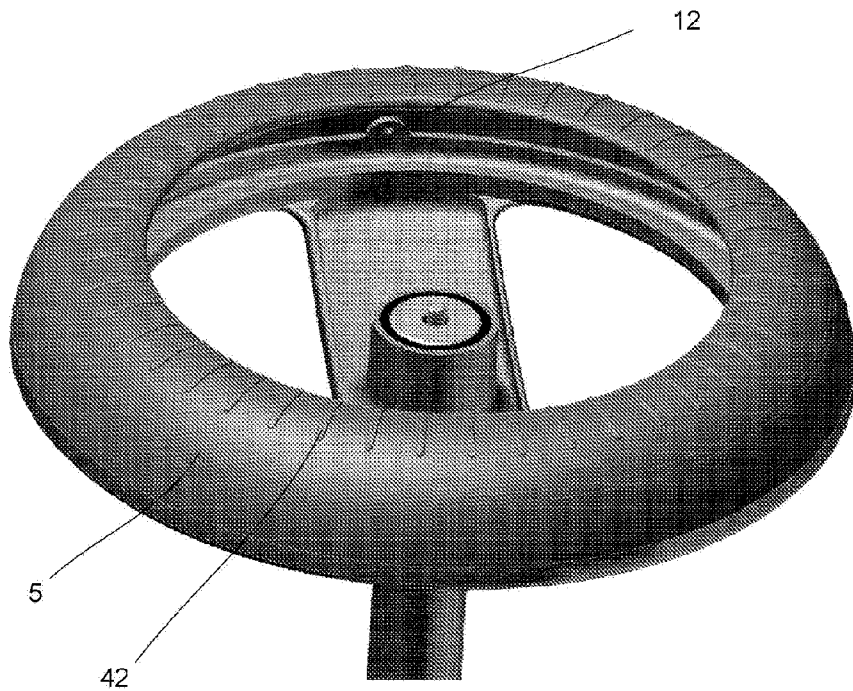

FIG. 11

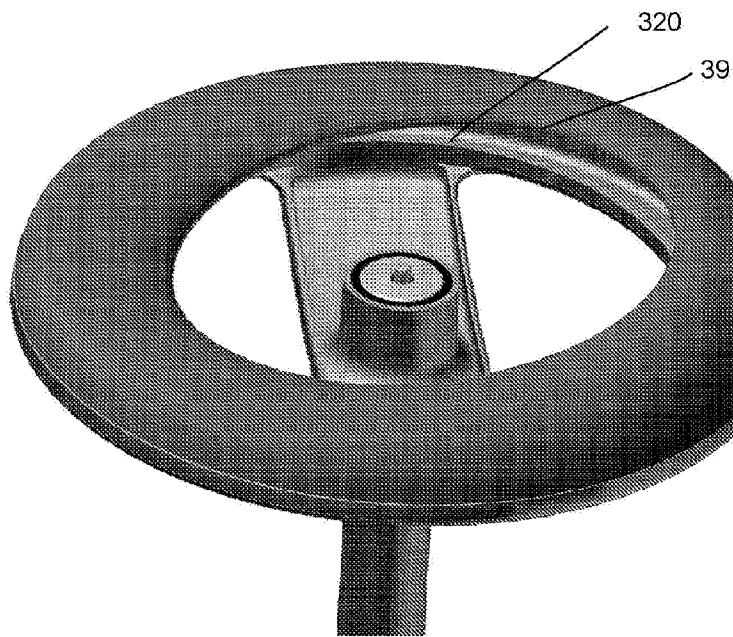

FIG. 12