

A. GREBE.  
 DRAW IN PERISCOPE.  
 APPLICATION FILED APR. 2, 1917.

1,298,333.

Patented Mar. 25, 1919.  
 2 SHEETS—SHEET 1.

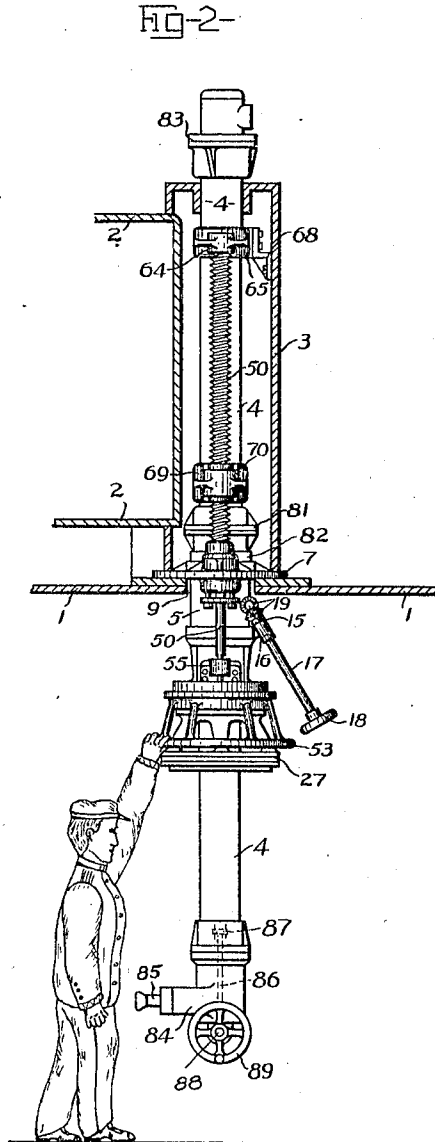
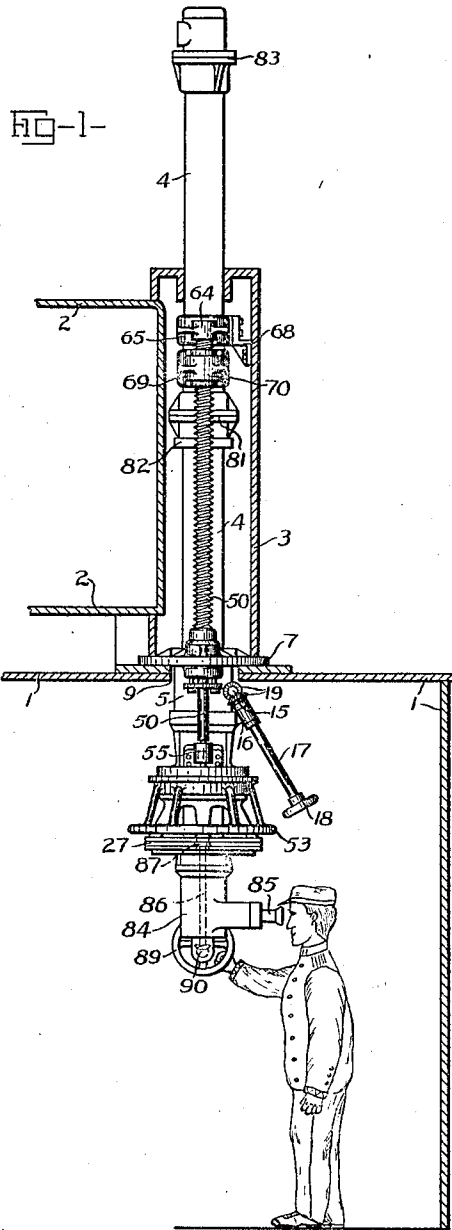

WITNESSES:  
*George D Powell*

INVENTOR  
*Albert Grebe*  
 BY *Shuck & Rich*  
 his ATTORNEYS

A. GREBE.  
 DRAW IN PERISCOPE.  
 APPLICATION FILED APR. 2, 1917.

1,298,333.

Patented Mar. 25, 1919.

2 SHEETS—SHEET 2.

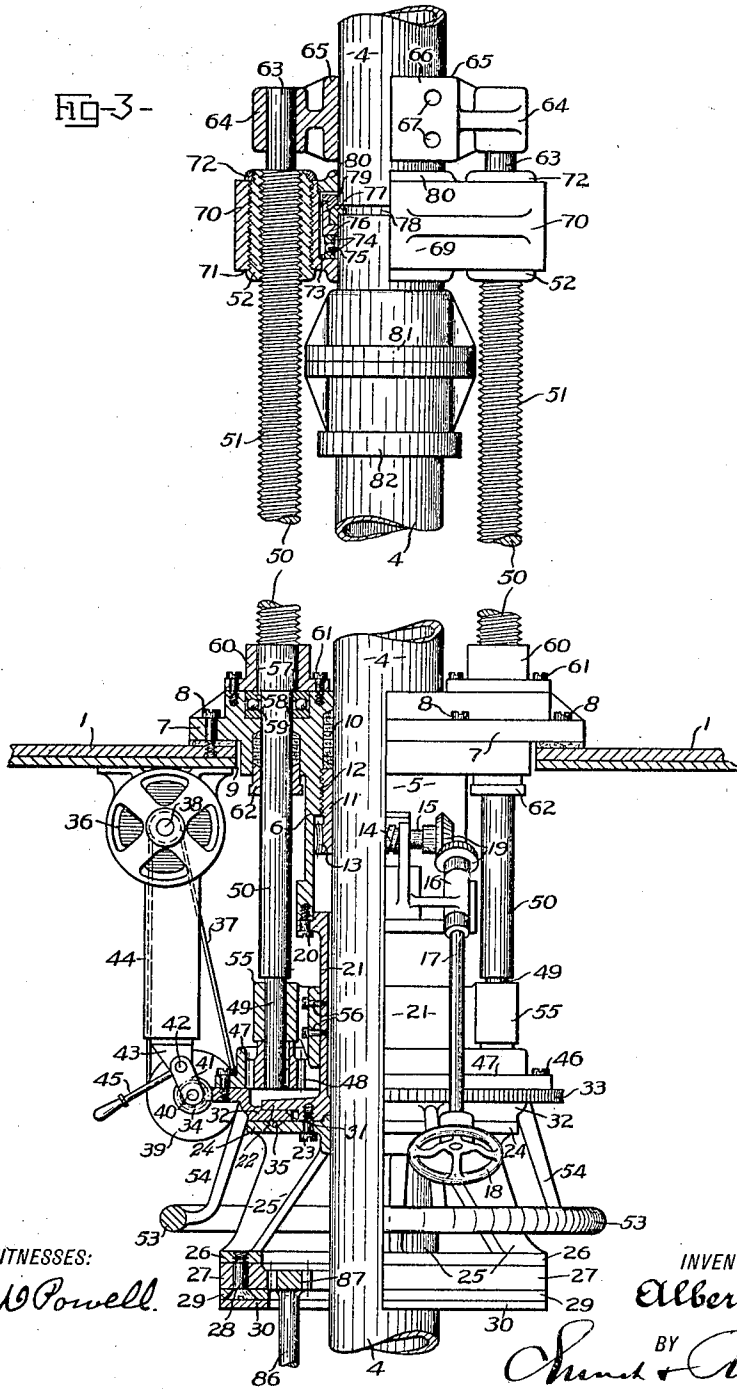

WITNESSES:  
*George W. Powell.*

INVENTOR  
*Albert Grebe*

BY *Shank & Rich*  
 his ATTORNEYS

# UNITED STATES PATENT OFFICE.

ALBERT GREBE, OF ROCHESTER, NEW YORK, ASSIGNOR TO BAUSCH & LOMB OPTICAL COMPANY, OF ROCHESTER, NEW YORK, A CORPORATION OF NEW YORK.

## DRAW-IN PERISCOPE.

1,298,333.

Specification of Letters Patent. Patented Mar. 25, 1919.

Application filed April 2, 1917. Serial No. 159,128.

*To all whom it may concern:*

Be it known that I, ALBERT GREBE, a citizen of the United States, residing at Rochester, in the county of Monroe, State of New York, have invented certain new and useful Improvements in Draw-In Periscopes; and I do declare the following to be a full, clear, and exact description of the same, reference being had to the accompanying drawings, forming part of this specification, and to the characters of reference marked thereon.

This invention relates to draw-in or disappearing submarine periscopes and has for its object to provide a periscope of this character having a water tight seal that may be loosened to permit the ready passage of the periscope tube therethrough, and tightened to prevent leakage after the periscope has been suitably raised or lowered, and also to provide a mechanism for supporting, raising and lowering the periscope which may be operated under control of the observer from within the vessel either by power or manually.

In the drawings:

Figure 1 is a sectional elevation of portions of the hull of a vessel with the improved periscope fitted thereto, and with its sighting tube shown fully raised. Fig. 2 is a sectional elevation showing the tube fully lowered. Fig. 3 is an enlarged partly broken out sectional front elevation of the periscope tube and its actuating mechanism, and parts of the vessel's hull to which the periscope foundation or support is secured.

The numeral 1 indicates portions of the hull of a submarine, 2 indicates part of its conning tower, and 3 indicates a chamber connected to and supported by the parts 1, 2, and protectively inclosing upper portions of a periscope tube and its operating mechanism. The periscope tube or casing 4 is supported for lengthwise movement and for rotation about its axis in a stuffing box 5 the outer wall 6 of which is a pendent tubular portion of a foundation or bedplate 7 bolted at 8 to the hull 1 around an opening 9 therein through which the periscope tube and portions of its operating mechanism pass in setting up the instrument. Within a counterbore of the stuffing box is placed any suitable elastic packing 10 surrounding the tube 4 and adapted for compression or release by a gland 11 shown screwthreaded at 12 into

the stuffing box wall 6 and carrying a worm wheel 13 engaged by a worm 14 fast on a horizontal shaft 15, rotatable in bearings held to the wall 6 which has another inclined bearing 16 supporting a shaft 17 carrying a hand wheel 18. By manually turning the wheel 18 in one direction, a pair of bevel gears 19 on the shafts 15, 17, will turn the worm gearing 13, 14 to force the gland 11 inward to more tightly compress the packing 10 to make a positively fluid tight joint of it with the raised or lowered periscope tube 4, and when the wheel 18 is reversely turned slightly the gland 11 will be withdrawn sufficiently to temporarily release or loosen the packing 10 to an extent permitting free upward or downward movement of the periscope tube in the stuffing box with practically no obstructing friction at said box and therefore with a minimum expenditure of power. The loosened packing excludes water from the boat's hull during raising or lowering of the tube and may absorb sufficient water to lubricate the moving tube.

To the lower end of the fixed stuffing box wall 6 is bolted at 20 the upper flanged end of a deep collar 21 which loosely surrounds the periscope tube 4 and at its lower end fixedly carries a horizontal flange 22 which is bolted at 23 to a bearing ring 24 having pendent and preferably flared arms 25 fixedly carrying a ring 26 to which an internal gear ring 27 is held by screws 28 passed through a clamping ring 29 to the outer face of which is fixed a graduated pelorus ring 30 readable relatively to a suitable index not shown because the ring scale and index form no part of this invention. The flange 22 and bearing ring 24 preferably form an unpacked steadying bearing below the stuffing box 5 for the long periscope tube 4. The lower face of the flange 22 is peripherally recessed to loosely receive an inner annular flange bearing 31 formed on an offset ring 32 having a peripheral worm gear 33 engageable by a motor driven worm 34. Ball bearings 35 are preferably placed between the parts 22, 24, to minimize friction attending rotation of the worm gear flange bearing 31.

An electric motor 36 secured to the boat hull 1 drives any suitable intermediate mechanism rotating the worm gear 32 and the worm 34, the driving mechanism shown

being a silent chain 37 running from a pinion 38 on the motor shaft to a sprocket wheel 39 whose stub shaft 40 fixedly carries the worm 34. The shaft 40 is journaled in the short arm 41 of an elbow lever fulcrumed at 42 to brackets 43 fixed to a hanger 44 fastened overhead to the baseplate of the motor 36. The long arm 45 of the elbow lever is formed as a handle which when manually lifted swings the wheel 39, the shaft 40 and the worm 34 outward to disengage the worm 34 from the worm wheel 32-33.

To the rotatable gear carrying bearing ring 32 is bolted at 46 the flange of an internal gear ring 47 the teeth of which are engaged by two pinions 48 keyed to the reduced lower ends 49 of two diametrically opposite vertical shafts 50 having screw threads 51 on which travel one at each side of the periscope tube 4, two nuts 52 held in a yoke which is movable for raising and lowering the tube as the screw shafts are rotated together in one direction or another either by the motor driven gearing 48, 47, 32, 33, 34, or manually as the ring worm gear 32, 33, is turned by a hand wheel 53 fixed to it by pendent spokes 54. The lower journals 49 of the shafts 50 rotate in bearings 55 bolted at 56 to facets on the fixed collar 21. Above its journal 49 each screw 50 is somewhat reduced in diameter thus providing a thrust shoulder 57 on the shaft about at the level of the top of the main foundation 7 which is recessed to provide a seat for the two races 58 and interposed balls 59 of an antifriction thrust ball bearing upon which the shaft shoulder 57 rests and which is held in place by a flanged collar 60 surrounding an unthreaded portion of the screw shaft and fastened to the foundation 7 by bolts 61. The foundation 7 also is recessed from below to accommodate a packing and gland forming a stuffing box 62 around the shaft 50 below the thrust ball bearing, said parts 60, 62, forming an intermediate bearing for the screw shaft.

The reduced upper journal 63 of each screw shaft 50 rotates in a bearing 64 on a collar 65 loosely fitting the periscope tube 4 and forming an upper guide for it while holding the two screw shafts parallel. This bearing collar 65 has a facet 66 having threaded holes 67 adapted to receive bolts holding it to a steadying adapter 68 which is bolted to the adjacent wall of the chamber 3, or it may be to the conning tower 2. The nuts 52 engaging the shaft screw threads 51, are preferably made separate from the tube operating yoke 69 and are externally threaded to engage internal threads of the opposite end parts 70 of this yoke. At its lower part the nut 52 has a shoulder 71 limiting the screwing of it into the yoke portion 70, and at its reduced upper end the nut 52 receives by a finer or differential thread a locking

ring or nut 72 which overlies the yoke end 70 and prevents loosening of the nut 52 during its travel on the shaft 50. The yoke 69 is centrally recessed deeply at 73 and at the bottom of this recess is placed an antifriction thrust bearing comprising two races 74 and interposed balls 75. On this thrust bearing rests a composite thrust ring comprising an internally recessed annulus 76, a split collet 77 resting in the recess of part 76 and having an inturned lip or flange fitting tightly within a circumferential groove 78 formed in the periscope tube 4, and a retaining collar 79 screwed into the top of the part 76, and holding the collet securely in operative engagement with the tube groove 78. A cap ring 80 screwed into the recess 73 holds the thrust bearing parts 74, 75, and the thrust ring parts 76, 77, 79, within the yoke recess 73. As the screws 50 are turned in one direction the nuts 52 and the connected yoke 69 will be raised to correspondingly raise the periscope tube 4 by the engaging collet 77, and if the screws be turned in the opposite direction the yoke will be lowered to lower the tube.

The periscope tube 4 is usually made in two lengths and a coupling 81 permanently connects the two tube portions. Below this coupling is fixed to the tube a stop ring 82 which by striking the foundation 7, limits descent of the tube and supports it when the periscope is not in use. The periscope tube carries an objective head 83, and has an ocular head 84 provided with an eye piece 85 into which the observer looks to view the images of ships or objects within the field of the objective as the tube 4 is turned axially. To thus turn the tube there is journaled on the ocular head 84, a vertical shaft 86 fixedly carrying a pinion 87 which meshes with the teeth of the stationary internal gear 27 above mentioned when the periscope is fully raised. To the foot piece 84 also is journaled a horizontal shaft 88 carrying a hand wheel 89. A pair of preferably incased bevel gears 90 operatively connect the two shafts 86, 88, whereby as the wheel 89 is conveniently turned by the observer looking into the eye piece 85, the rotating pinion 87 by engaging the fixed internal gear 27, will axially turn the entire periscope tube 4 in either direction as controlled by the direction of rotation of the wheel 89, and thus the entire horizon may be scanned as desired by the observer who walks around as the tube turns on its axis and while he is protected within the hull 1 of the vessel. During axial turning of the tube 4 the thrust ring parts 76, 77, 79, turn with it as the ring turns upon the ball bearing 74, 75, while the upper ball race 74 may turn more or less in the yoke 69, to minimize friction and assure easy turning of the heavy tube by manually turning the wheel 89, notwith-

standing the water sealing tightness of the packing 10 around the raised tube. As the periscope tube 4 is lowered from the fully raised position of use shown in Fig. 1, the pinion 87 on the shaft 86 will be automatically disengaged from the fixed gear 27, as shown by dotted lines in Fig. 2, and when the tube is next raised the pinion 87 will automatically mesh with the gear 27 in readiness for axially rotating the tube by turning the hand wheel 89.

When the periscope is in its fully raised position as shown in Fig. 1, the observer while looking into the eye piece 85 may axially turn the entire periscope tube 4 in either direction and to any extent by operating the conveniently placed hand wheel 89, to point the objective head 83 at any desired portion of the horizon. Prior to movement of the periscope tube either upward or downward the tube packing 10 will be loosened by drawing back the gland 11, to assure quick and easy vertical adjustment of the tube, and after every such adjustment the packing will again be tightened on the tube by advancing the gland to effectually water seal the tube joint with the main stuffing box 5.

Any suitable conductors may be used to connect the motor 36 with a source of electric energy, and any approved means such as a pole changer, may be used to reverse the direction of rotation of the motor to cause it to turn the screws 51 in reverse directions for raising and lowering the periscope tube, all as will readily be understood without special illustration.

Having thus described my invention, what I claim and desire to secure by Letters Patent of the United States is:

1. In a periscope, the combination of a foundation adapted to be fixed to the hull of a vessel and having an opening there-through, an observation tube in said opening, a screw supported on said foundation and substantially parallel with said observation tube, and means for moving the observation tube in said opening when the screw is rotated.

2. In a periscope, the combination of a foundation adapted to be fixed to the hull of a vessel and having an opening there-through, an observation tube in said opening, a pair of screws supported on said founda-

tion and substantially parallel with said observation tube, means operatively connecting said screws with said observation tube, and means for simultaneously rotating said screws for raising and lowering said observation tube on said foundation.

3. In a periscope, the combination of a foundation adapted to be fixed to the hull of a vessel and having an opening there-through, an observation tube in said opening, a pair of screws supported on said foundation substantially parallel with said observation tube, means operatively connecting said screws with said observation tube, a ring gear for simultaneously rotating said screws in one direction or another for raising or lowering said observation tube, and a hand wheel for turning said gear.

4. In a periscope, the combination of a foundation adapted to be fixed to the hull of a vessel and having an opening there-through, an observation tube in said opening, a collar surrounding said observation tube and supported on said foundation, an internal gear mounted on said collar, means for raising and lowering said observation tube, and a gear on said observation tube.

5. In a periscope, the combination of a foundation adapted to be fixed to the hull of a vessel, and having an opening there-through, an observation tube in said opening, a stuffing box in said foundation having a packing to water seal the observation tube, means for rotating said observation tube, means for raising and lowering said observation tube, and means accessible to the observer for releasing said packing when the observation tube is raised or lowered.

6. In a periscope, the combination of a foundation adapted to be fixed to the hull of a vessel, and having an opening there-through, an observation tube in said opening, a stuffing box in said foundation having a packing to water seal the observation tube, a gland for applying pressure to said packing, a worm for actuating said gland, means for rotating said observation tube, means for raising and lowering said observation tube, and means accessible to the observer for operating said worm to release the packing when the observation tube is raised.

ALBERT GREBE.

Copies of this patent may be obtained for five cents each, by addressing the "Commissioner of Patents, Washington, D. C."