

R. M. HUNTER.  
CASH REGISTER.

No. 521,931.

Patented June 26, 1894.

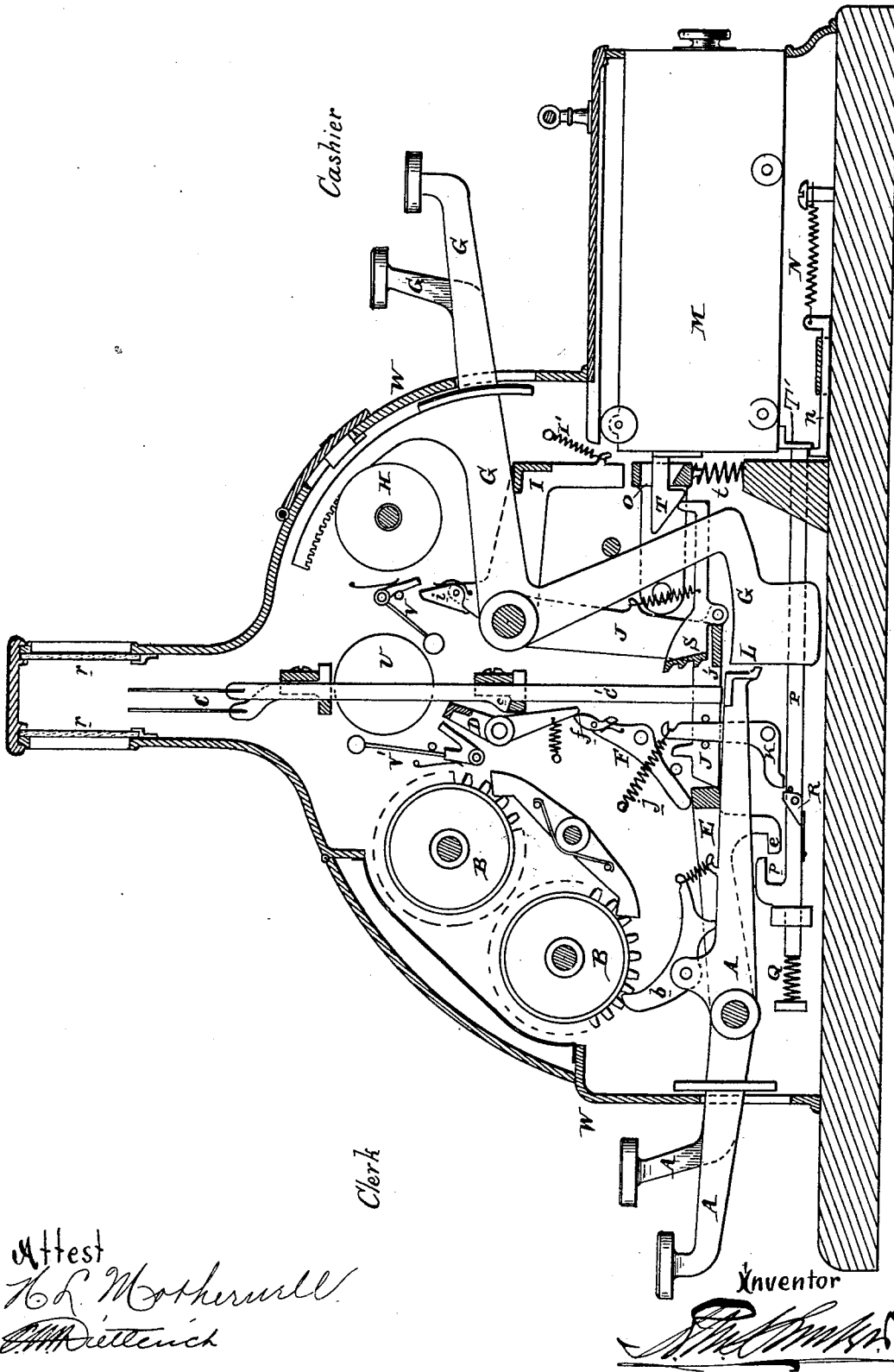

Fig. 1

Cashier

Clerk

Inventor

Attest  
H. L. Matherall  
A. A. Dietrich

*[Handwritten signature]*

R. M. HUNTER.  
CASH REGISTER.

No. 521,931.

Patented June 26, 1894.

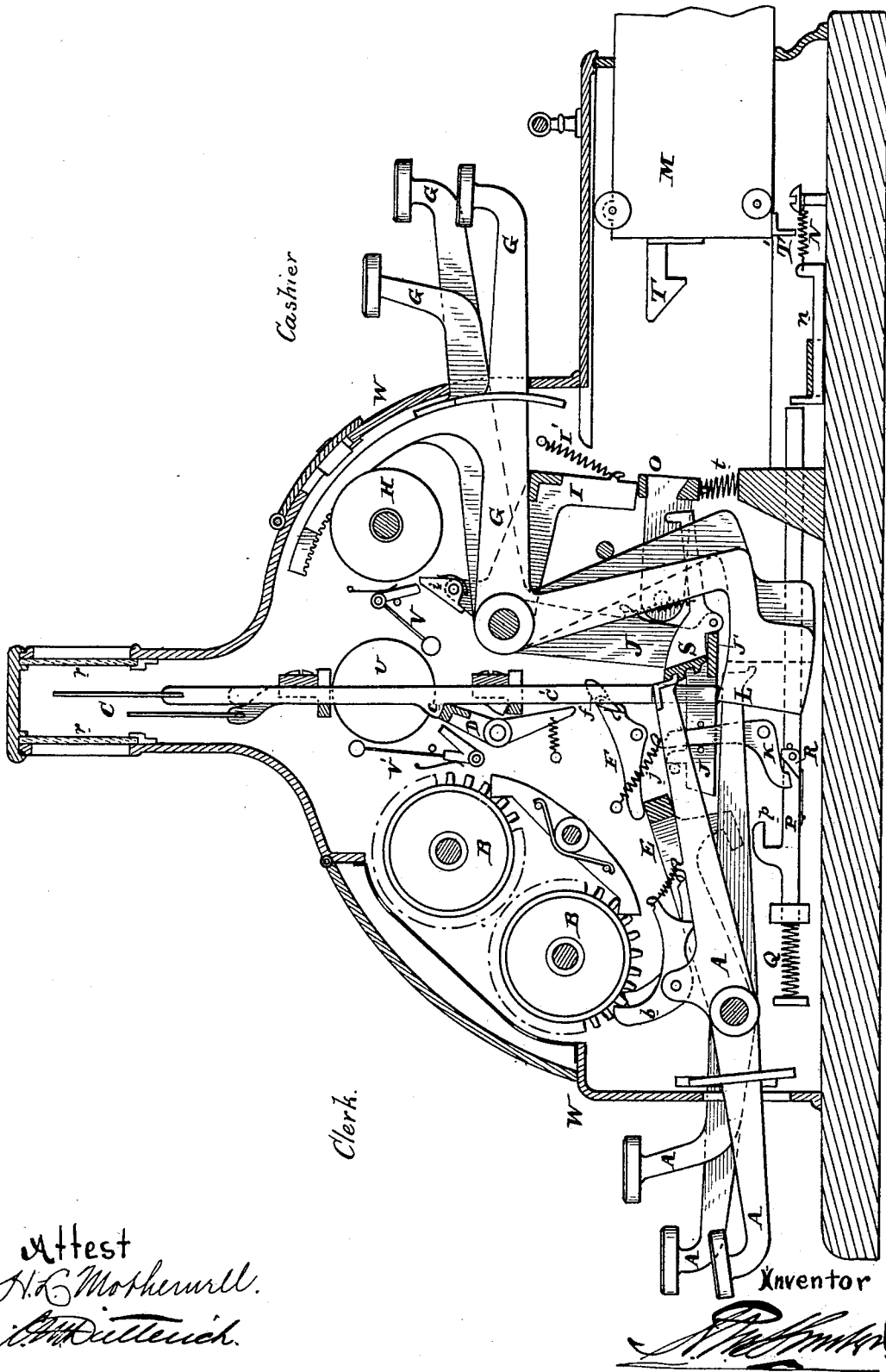

FIG. 2

Attest  
*H. C. Motherwell.*  
*A. W. Dittreich.*

Inventor  
*R. M. Hunter*

# UNITED STATES PATENT OFFICE.

RUDOLPH M. HUNTER, OF PHILADELPHIA, PENNSYLVANIA.

## CASH-REGISTER.

SPECIFICATION forming part of Letters Patent No. 521,931, dated June 26, 1894.

Application filed August 14, 1893. Serial No. 483,052. (No model.)

*To all whom it may concern:*

Be it known that I, RUDOLPH M. HUNTER, of the city and county of Philadelphia and State of Pennsylvania, have invented an Improvement in Cash-Registers, of which the following is a specification.

My invention has reference to cash registers, and consists of certain improvements which are fully set forth in the following specification and shown in the accompanying drawings which form a part thereof.

This application, Case No. 263, comprehends certain improvements in a class of cash registering machines adapted to be operated by a clerk and a cashier in making a single registry or record of a sale and in which the clerk has no control of the cash drawer, and on the other hand the cashier has no control of the keys except as may be dictated by the clerk.

The object of my improved machine is to provide a cash register which is to be jointly operated by a clerk in a store and also by the cashier to whom the money is paid. In machines as heretofore designed, the cash drawer has been under the control of the cashier only, and was adapted to be opened by the operation of any one key. In case the machine was where it could be reached through the cash window, and the cashier was absent, a key might be depressed and the drawer robbed. With my present machine all danger from sources of theft are amply provided against, and the cashier cannot under any circumstances operate the machine to release the drawer except when the clerk has operated the key for indicating the amount of the sale. The advantage of the machine will be better understood after a description of its construction is given.

In carrying out my invention I may employ a large variety of details and utilize to a considerable extent the forms of cash registers which have been heretofore placed on the market, modifying or adding to them to the extent required for the proper carrying out of my invention.

My improvement more essentially consists of one complete cash register such as is well known upon the market, but which is not designed to liberate a cash drawer, combined

with a second portion having an additional set of keys adapted to be locked or liberated by the movement of the corresponding keys in the first mentioned part or cash register, and in which the second set of keys operate to release a cash drawer under the control of the cashier. The operation of either or both sets of keys may sound an alarm as is customary in cash registers. The cash drawer must be closed to enable the clerk to operate a key thus preventing careless leaving of the drawer open.

I do not confine myself to any special details of construction as these may be greatly modified as will readily be understood by any one skilled in the art to which the invention appertains.

The accompanying Figure 1 is a vertical side sectional elevation of a cash register embodying my improvements and Fig. 2 is a similar view with the keys depressed.

The keys A operate the register wheels B and the indicator rods C' which raise the indicators C into view through the glass windows  $\tau$  in the ordinary manner of any cash register machine. The lugs  $c$  of the rods C' catch upon the support D when the indicator rods are raised. A frame E common to all of the keys A is adapted to operate the pivoted support D so as to release the indicator rods and indicators C each time a new key is operated substantially in the manner of the cash registers as now in use.

The operation of the pivoted support D from the frame E common to all of the keys A is performed through the media of the lever F which is pivoted to the main frame W and has its lower end in position to be operated on by the said frame E, and its upper end provided with a spring pawl  $f$  adapted to strike the lower end of the pivoted supporting frame D so as to move it in one direction and not in the other. When the frame E is raised it will be seen that the upper part of frame D will be moved away from the indicator rods to liberate any indicator rod C' which may have been previously supported, and also to permit the passage of the lug  $c$  of the rod C being raised by the key A last operated. A spring resets the support D to hold the rod or rods last raised. This mechanism

may be substantially of the character illustrated in Letters Patent No. 271,363, dated January 30, 1883.

The keys A are directed into the store where the clerks sell the goods, and are operated only by the clerks. A second set of keys G extend in the opposite direction from the keys A of the machine and are arranged within the cashier's desk or compartment and are operated only by the cashier. This second set of keys G may, if desired, operate a total adding register H of any suitable or well known construction which shall be a check upon the registers B, absolutely requiring the registrations of the cashier and clerks to balance, and also for the purpose of enabling the total amount of sales at any time during the day to be readily ascertained. There are as many keys G as there are keys A, and the lower part of each key G is provided with a part L which will strike the end of the key A unless the rear end thereof is elevated. It will thus be seen that the keys G are all locked against movement except when the keys A are operated, and in that event only the keys G corresponding to the keys A operated are movable. This absolutely requires the cashier to depress the proper keys. When the key A is depressed the rear end is raised and catches upon the dog S and is locked in its raised position thereby. The dog S moves to the left the moment the frame E is lifted by any of the keys A, for then the frame J is pulled to the left by the spring j. The dog S necessitates that the key A shall be raised its full height for it cannot be lowered until one of the keys G has been brought into operation. When the rear end of any key A is raised, the corresponding key G is depressed by the cashier, and said action depresses the frame I common to all of the keys G, putting the spring I' under tension and depressing the pivoted spring bolt O, thereby releasing the latch T, and permitting the spring N to force the cash drawer M open. The instant the drawer opens, the dog S oscillates and firmly locks the rear elevated end of the key A. It will now be observed that the key A is locked and the frame E is elevated and no other key can be elevated because the part J' of the frame J has moved to the left so as to be slightly over the rear ends of the keys A which have not been moved. The machine is again set in operative condition simply by the cashier closing the drawer. When the drawer is pushed in, its latch snaps back of the spring bolt or catch O and is again locked. In moving backward the lug T' of the drawer strikes the slide bar P and moves the dog R to the left under the lower end of the bell crank lever, thereby throwing back the pivoted frame J and the dog S, which latter striking the oblique face of the latch T quickly liberates the keys A which were firmly locked in their raised condition, allowing them to reset themselves into the position shown in the drawings, and the machine is once more

ready for a further operation. When the frame J has been moved backward by the pivoted lever K the frame E is lowered in front of it and prevents it returning thereby releasing all of the keys A. If from any cause the drawer should be opened without moving the keys, the slide bar P will move to the right and the catch p will lock the hook e on the frame E and thereby lock all of the levers A and through them all of the levers G. These parts p, e may be dispensed with if desired.

From this construction of machine it is evident that absolute collusion between the cashier and clerk would be necessary to enable theft, and then in so doing it would be necessary to ring up the wrong amount, and this would at once be indicated by the indicators.

The operation of any key of either set may be required to sound an alarm upon a bell U by the operation of the hammer V or V' operated by suitable trip devices from the respective frames I and E, which are respectively common to all of the keys G and A. The frame E may operate the hammer V' through the frame D, or by an additional frame F which directly operates upon the hammer in the manner set out in the aforesaid Letters Patent. The frame I has a pivoted spring pawl i which directly operates upon the bell hammer V as will be readily understood, so that when any key G is depressed, the hammer V is operated.

A person entering the cashier's compartment with the intent of theft could not by any manipulation of the keys G open the drawer. To accomplish this object he would first have to go around to the outside and depress the necessary key which would cause an alarm to be sounded; he would then have to go to the inside of the compartment and depress a particular one of the keys G which would take time and besides would cause a second alarm to be sounded before he could get the drawer open. This is an important precaution in case of the temporary absence of the cashier, or where the cashier is required to perform other duties than that of receiving the money, and where it is desired that the clerks shall not have access to the cash drawer.

It will be understood that the various parts illustrated may be greatly varied in shape or detail as the invention is not confined to these minor points, but comprehends broadly a machine of the class herein described in which the two sets of keys are required, one set being locked or liberated by the operation of the other set.

What I claim as new, and desire to secure by Letters Patent, is—

1. In a cash register, the combination of a series of keys, a series of indicators adapted to be operated by said keys, a second set of keys locked against movement by the first set of keys except when any key of the first set is moved to expose its indicator, a cash drawer, a lock to hold said cash drawer in a

closed position, and means under control of the second set of keys to operate the lock to release the drawer.

2. In a cash register, the combination of a series of keys, a series of indicators adapted to be operated by said keys, a second set of keys locked against movement by the first set of keys except when any key of the first set is moved to expose its indicator, a cash drawer, a lock to hold said cash drawer in a closed position, means under control of the second set of keys to operate the lock to release the drawer, and a spring to force the drawer open when released.

3. In a cash register, the combination of a series of keys, a series of indicators adapted to be operated by said keys, a second set of keys locked against movement by the first set of keys except when any key of the first set is moved to expose its indicator, a cash drawer, a lock to hold said cash drawer in a closed position, means under control of the second set of keys to operate the lock to release the drawer, a latch to lock all of the first mentioned set of keys when any one of them has been operated, and releasing devices under the control of the second set of keys to operate said latch to release all of the said first mentioned keys.

4. In a cash register, the combination of a series of keys, a series of indicators adapted to be operated by said keys, a second set of keys locked against movement by the first set of keys except when any key of the first set is moved to expose its indicator, a cash drawer, a lock to hold said cash drawer in a closed position, means under control of the second set of keys to operate the lock to release the drawer, a latch to lock all of the first mentioned set of keys when any one of them has been operated, releasing devices under the control of the second set of keys to operate said latch to release all of the said first mentioned keys, and connecting devices between the cash drawer and latch device to prevent the releasing of the first mentioned keys until the cash drawer is locked.

5. In a cash register, the combination of a series of keys, a series of indicators adapted to be operated by said keys, a second set of keys locked against movement by the first set of keys except when any key of the first set is moved to expose its indicator, a cash drawer, a lock to hold said cash drawer in a closed position, means under control of the second set of keys to operate the lock to release the drawer, and registering devices for registering the amount of the sales by the operation of the keys.

6. In a cash register, the combination of a series of keys, a series of indicators adapted to be operated by said keys, a second set of keys locked against movement by the first set of keys except when any key of the first set is moved to expose its indicator, a cash drawer, a lock to hold said cash drawer in a closed position, means under control of the second set

of keys to operate the lock to release the drawer, a spring to force the drawer open when released, and registering devices for registering the amount of sales by the operation of the keys.

7. In a cash register, the combination of a series of keys, a series of indicators adapted to be operated by said keys, a second set of keys locked against movement by the first set of keys except when any of the first set is moved to expose its indicator, a cash drawer, a lock to hold said cash drawer in a closed position, means under control of the second set of keys to operate the lock to release the drawer, a latch to lock all of the first mentioned set of keys when any one of them has been operated, releasing devices under the control of the second set of keys to operate said latch to release all of the said first mentioned keys, and registering devices for registering the amount of the sales by the operation of the keys.

8. In a cash register, the combination of a series of keys, a series of indicators adapted to be operated by said keys, a second set of keys locked against movement by the first set of keys except when any key of the first set is moved to expose its indicator, a cash drawer, a lock to hold said cash drawer in a closed position, means under control of the second set of keys to operate the lock to release the drawer, a latch to lock all of the first mentioned set of keys when any one of them has been operated, releasing devices under the control of the second set of keys to operate said latch to release all of the said first mentioned keys, connecting devices between the cash drawer and the latch device to prevent the releasing of the first mentioned keys until the cash drawer is locked, and registering devices for registering the amount of the sales by the operation of the keys.

9. In a cash register, the combination of a series of keys, a series of indicators adapted to be operated by said keys, a second set of keys locked against movement by the first set of keys except when any key of the first set is moved to expose its indicator, a cash drawer, a lock to hold said cash drawer in a closed position, means under control of the second set of keys to operate the lock to release the drawer, and separate registering devices under the control of each set of keys.

10. In a cash register, the combination of a series of keys, a series of indicators adapted to be operated by said keys, a second set of keys adapted to be moved independently of the first set or series of keys the movement of which is controlled by the first set of keys, and registering mechanism operated by the operation of said keys.

11. In a cash register, the combination of a series of keys, a series of indicators adapted to be operated by said keys, a second set of keys adapted to be moved independently of the first set or series of keys, the movement of which is controlled by the first set of keys, registering mechanism operated by the oper-

ation of said keys, and an alarm adapted to be sounded upon the operation of any key.

12. In a cash register, the combination of a series of keys, a series of indicators adapted to be operated by said keys, a second set of keys adapted to be moved independently of the first set or series of keys the movement of which is controlled by the first set of keys, registering mechanism operated by the operation of said keys, alarm devices and mechanism controlled by each set of keys whereby the operation of any key of either set will sound an alarm.

13. In a cash register, the combination of a series of keys, a series of indicators adapted to be operated by said keys, a second set of keys the movement of which is controlled by the first set of keys, registering mechanism operated by the operation of said keys, a cash drawer controlled by the operation of the said keys, and a lock controlled by the cash drawer to lock the first mentioned set of keys when the cash drawer is open.

14. In a cash register, the combination of a series of keys, a series of indicators adapted to be operated by said keys, a second set of keys the movement of which is controlled by the first set of keys, registering mechanism operated by the movement of said keys, and latching devices controlled by the operation of the said keys for locking the keys of the first set which have not been actuated against movement and to lock the keys of the first set which have been operated in their moved position.

15. In a cash register, the combination of a series of keys, a series of indicators adapted to be operated by said keys, a second set of keys the movement of which is controlled by the first set of keys, registering mechanism operated by the movement of said keys, latching devices controlled by the operation of the said keys for locking the keys of the first set which have not been actuated against movement and to lock the keys of the first set which have been operated in their moved position, a cash drawer and devices controlled by the cash drawer for resetting the latching devices for the purpose of liberating the first set of keys.

16. In a cash register, the combination of a set of keys, mechanism operated thereby for registering or indicating the amount of the sales, a cash drawer, a lock for holding the cash drawer in a locked position, hand operated devices for operating the lock controlled by the movement of any of the first mentioned keys, and registering devices operated by the devices for operating the lock.

17. In a cash register, the combination of a set of keys a cash drawer, a lock for holding the cash drawer in a locked position, hand operated devices for operating the lock controlled by the movement of any of the first mentioned keys, and registering devices operated by the devices for operating the lock.

18. In a cash register, the combination of a

set of keys a cash drawer, a lock for holding the cash drawer in a locked position, hand operated devices for operating the lock controlled by the movement of the first mentioned keys, registering devices operated by the devices for operating the lock, and alarm mechanism operated by the movement of the keys.

19. In a cash register, the combination of a set of keys a cash drawer, a lock for holding the cash drawer in a locked position, hand operated devices for operating the lock controlled by the movement of any of the first mentioned keys, registering devices operated by the devices for operating the lock, and indicating devices adapted to be thrown into view during the operation of the machine.

20. In a cash register, the combination of a series of keys, a series of indicating devices adapted to be operated by the said keys, a cash drawer, a lock to lock the said cash drawer, and a series of independent hand operated lock releasing devices the movement of which is controlled by the said keys to release the drawer.

21. In a cash register, the combination of a series of keys, a series of indicating devices adapted to be operated by the said keys, a cash drawer, a lock to lock the said cash drawer, a series of independent hand operated lock releasing devices the movement of which is controlled by the said keys to release the drawer, and registering devices controlled by the operation of the keys for registering the amount of the sales indicated.

22. In a cash register, the combination of one set of keys, indicating and registering devices operated by the said keys, a second set of keys pointing in the opposite direction to the first mentioned set, a cash drawer in connection with the second set of keys, a lock to lock the cash drawer controlled by the second set of keys whereby any one of the second set of keys could be operated to release the cash drawer only when the corresponding key of the first set has been moved.

23. In a cash register, the combination of two sets of keys pivoted in two rows and pointing in opposite directions and having their adjacent ends brought into line so that any keys of one set cannot be operated until the corresponding keys of the other set have been moved.

24. In a cash register, the combination of two sets of keys pivoted in two rows and pointing in opposite directions and having their adjacent ends brought into line so that any key of one set cannot be operated until the corresponding key of the other set has been moved, and indicating mechanism controlled by the movement of said keys to make an indication corresponding to the denomination of the key moved.

25. In a cash register, the combination of two sets of keys pivoted in two rows and pointing in opposite directions and having their adjacent ends brought into line so that

any key of one set cannot be operated until the corresponding key of the other set has been moved, indicating mechanism controlled by the movement of said keys to make an indication corresponding to the denomination of the key moved, a cash drawer, and a lock for said cash drawer controlled by the movement of said keys.

26. In a cash register, the combination of a series of straight lever keys combined with a series of bell crank shaped pivoted keys pointing in the opposite direction and having their rear ends brought into line with the rear ends of the first mentioned straight lever pivoted

keys whereby the bell crank shaped keys are locked against movement until the corresponding straight lever keys are moved, devices controlled by the straight lever keys to indicate the amounts corresponding to said keys moved, a cash drawer, and a lock for said cash drawer controlled by the bell crank shaped keys.

In testimony of which invention I have hereunto set my hand.

R. M. HUNTER.

Witnesses:

ERNEST HOWARD HUNTER,  
HELEN L. MOTHERWELL.