

(No Model.)

2 Sheets—Sheet 1.

J. GEISER.
LAMP.

No. 524,526.

Patented Aug. 14, 1894.

FIG:1.

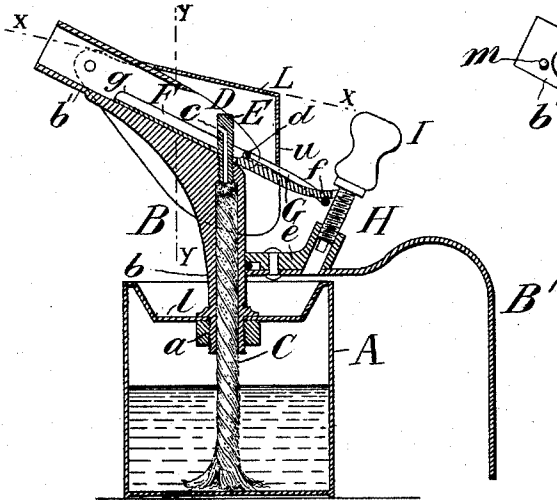

FIG:2.

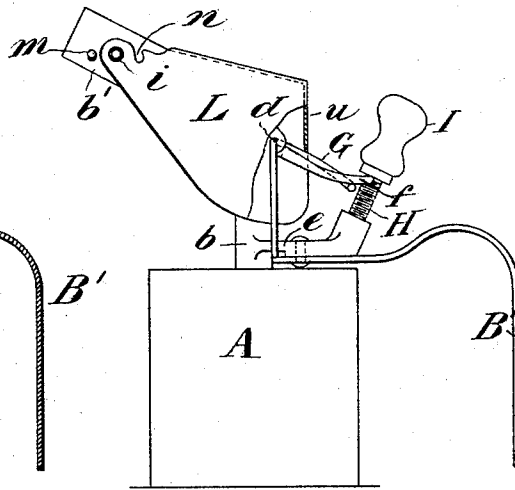

FIG:3.

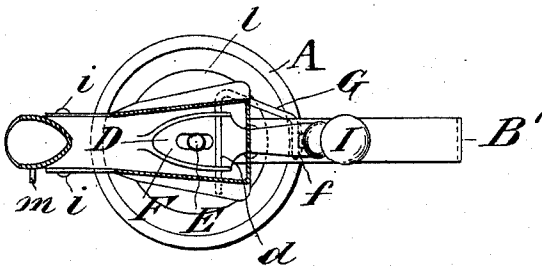
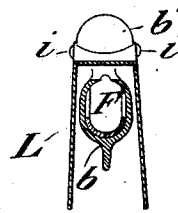

FIG:4.



Witnesses:

J. H. W. Wiman
Peter A. Ross

Inventor:

Jacob Geiser
by Henry Bennett
for Attorney

(No Model.)

2 Sheets—Sheet 2.

J. GEISER.
LAMP.

No. 524,526.

Patented Aug. 14, 1894.

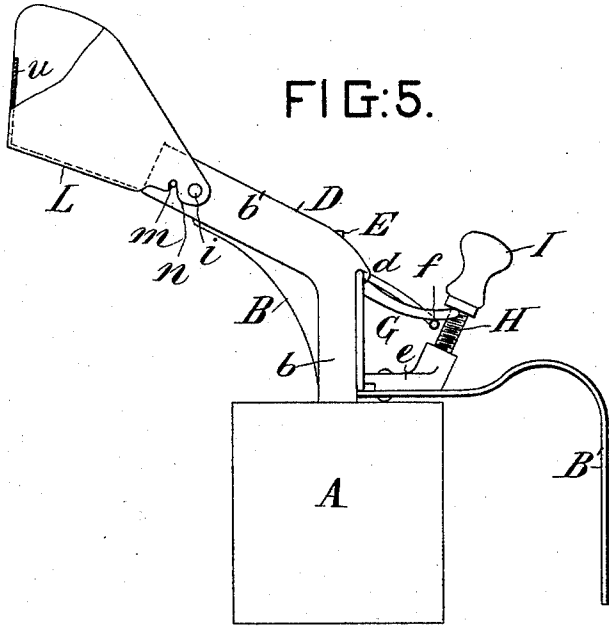
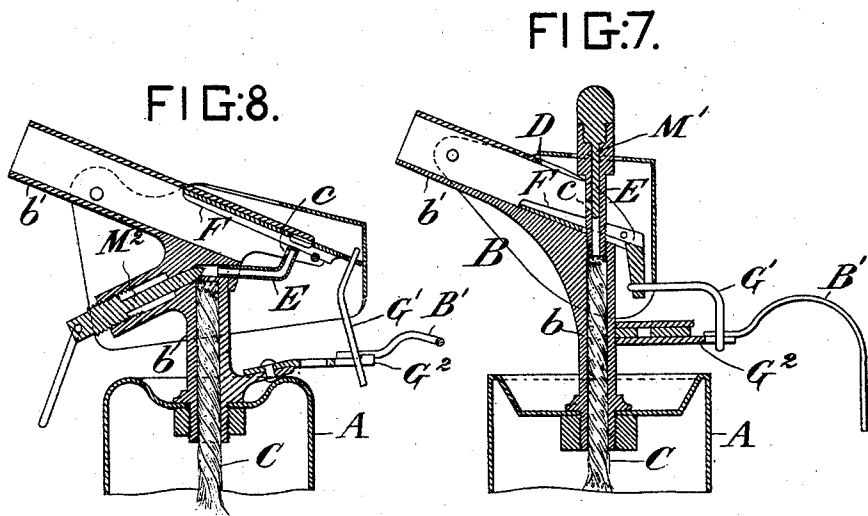

FIG:6.



Witnesses:
S. W. Bliman
Peter A. Ross

Inventor:
Jacob Geiser
 by *Henry Cornells*
his Attorney

UNITED STATES PATENT OFFICE.

JACOB GEISER, OF BASLE, SWITZERLAND.

LAMP.

SPECIFICATION forming part of Letters Patent No. 524,526, dated August 14, 1894.

Application filed April 3, 1894. Serial No. 506,141. (No model.) Patented in Switzerland May 12, 1892, No. 5,036.

To all whom it may concern:

Be it known that I, JACOB GEISER, a subject of the German Emperor, residing at Basle, in the Republic of Switzerland, have invented
5 certain Improvements in Lamps Chiefly Designed for Soldering Purposes, (for which a patent has been granted to me in Switzerland, No. 5,036, dated May 12, 1892,) of which the following is a specification.

10 This invention relates to the class of lamps wherein the vapor generated by the application of heat to the wick-tube, is burned in lieu of the inflammable liquid itself; and the object of the invention is, in the main, to effect the regulation of the volume and force of
15 the flame from the burner, but I have in view also other features of improvement all of which will be hereinafter fully described and the novel features of the invention carefully
20 defined in the claims.

In the accompanying drawings, which illustrate my invention embodied in a lamp for use in soldering—Figure 1 is a vertical mid-section of the lamp. Fig. 2 is a side elevation thereof. Fig. 3 is a section substantially
25 in the plane indicated by the line x, x , in Fig. 1. In this view the main portion of the lamp is seen in plan. Fig. 4 is a vertical, transverse section of the combustion tube, substantially in the plane indicated by line y, y ,
30 in Fig. 1. Fig. 5 is a view similar to Fig. 2 but showing the cap or hood L, shifted and inverted. Fig. 6 represents the cap for the burner tube, detached. Figs. 7 and 8 are sectional views illustrating slightly modified
35 constructions which will be hereinafter described.

In the description I will first refer to Figs. 1 to 6, inclusive.

40 A is the lamp-body or reservoir, the top l , of which is depressed to form a receptacle for an inflammable liquid, and provided with a filling aperture. In this aperture is screwed the nipple, a , of the wick-tube.

45 B is a metallic piece or part, the lower portion of which forms the upright wick-tube, b , and the upper portion, which is inclined to the wick-tube, forms the combustion tube, b' .

50 C is the wick, in the wick-tube, and E is the burner, screwed into the top of the wick-tube. This burner has a lateral outlet, c , for

the combustible vapors. At the point where the burner E is situated the upper portion or crown of the part B is cut away to form an opening, D.

B' is the handle of the lamp, secured to a bracket, e , on the wick-tube. 55

L is a cap or hood, pivoted to the tube b' at i .

So far as described, the lamp is operated as follows: The reservoir A is filled with some
60 inflammable liquid, as benzine, spirits, or the like, and the depression in its top is also filled with the same or a similar liquid, this latter liquid is ignited and it heats the wick-tube to such an extent as to vaporize the liquid raised
65 by the wick and the vapor issues at the aperture c , of the burner, where it may be ignited. The ignited gases expand and fill the tube b' , issuing therefrom very forcibly and in considerable volume if the aperture c , be turned
70 so as to co-incide with the axis of the tube b' . If the flame be too voluminous and be projected too far for the purposes of the use, he may regulate the force and volume in what
75 may be termed a permanent manner by turning the burner E axially so as to cause the jet of vapor to be directed more or less obliquely toward the wall of the tube b' . This regulation will be made when the lamp is not
80 ignited and cannot well be changed while the lamp is in operation.

In order that the user may regulate the volume of the flame momentarily and at will while the lamp is in operation, I provide a regulating device which will now be described. 85

In the tube b' , is mounted a tongue F, pivoted in the part B at d , in any convenient manner. This tongue is slotted so as to permit the burner E to pass through it, and it will be made to conform to the tube b' , in
90 cross-section, as indicated in Fig. 4. The tail portion, f , of this tongue is forked and takes under a shoulder formed by a head, I, on a screw, H, which screws into a socket in the bracket e , whereby, when said screw is made
95 to depress the fork f , the end or portion, g , of the tongue F which lies in the tube b' , will be elevated in such a manner as to deflect upward and obstruct the passage of the ignited vapors through the tube b' , and thus regulate
100 the flame. A suitable spring may be arranged under the forked tail f of the tongue F. The

spring here shown is a bent wire G; one end of this wire takes under the fork *f*, a portion of it forms the pivot at *d*, and the other end extends down and is fastened under the bracket *e*. In Fig. 2 a part of the side-plate of the hood L is broken away to show the spring G. This particular form of the spring is not material to my invention.

The hinged hood L prevents the flame from spreading upward and to the rear through the opening D, when it is desired that it shall be projected through the tube *b'*. If it be desired to use the lamp for heating a vessel placed above it, the hood L may be thrown or turned over to the inverted position seen in Fig. 5, in which position it will be supported by studs *m*, which may engage nicks *n*, in the hood. When in this inverted position the back plate, *u*, of the hood will serve to baffle and direct upward the flame that may be projected through the tube *b'*.

The cap M, seen in Fig. 6, may be placed over the burner E to prevent evaporation of the liquid in the lamp when the latter is not in use.

In the modified construction illustrated in Fig. 7, a screw stopper, M', adapted to screw down into the top of the burner E to a greater or less extent and thus close or open the aperture *c*, is employed in lieu of the cap M; and in the modified construction of Fig. 8, a similar screw stopper, M², screws into the wick-tube *b* just above the wick, for the same purpose. In this modification the aperture *c*, from which the vapor escapes, is arranged below the tongue F, and in the modifications of Figs. 7 and 8, the tongue F, is operated by a handle, G, thereon, the end of which plays in

a slot formed in the bracket, G², which supports the handle B', of the lamp.

Having thus described my invention, I claim—

1. A lamp of the character described having an upwardly inclined combustion tube *b'*, a burner projecting upwardly into said tube and having a jet aperture *c* arranged to direct the flame axially through the tube, and a flame-regulating tongue, F, pivotally mounted in said tube back of the burner and having in it a slot through which the burner projects, substantially as set forth.

2. In a lamp for burning vapors generated from volatile liquids, the combination with the wick-tube, the combustion tube, and the burner, of a hinged, flame-regulating tongue F, in the combustion tube, said tongue having a rearwardly projecting tail-portion, *f*, a screw for depressing this portion *f* of the tongue, and a spring under said portion *f*, substantially as set forth.

3. In a lamp for burning vapors from volatile liquids, the combination with the wick-tube, the combustion tube, and the burner, of the hood L, hinged to the combustion tube as set forth, whereby said hood serves, when in its normal position, to house the burner and when in its inverted position, to deflect the flame upward, substantially as described.

In witness whereof I have hereunto signed my name in the presence of two subscribing witnesses.

JACOB GEISER.

Witnesses:

GEORGE GIFFORD,
AMAND RITTER.