

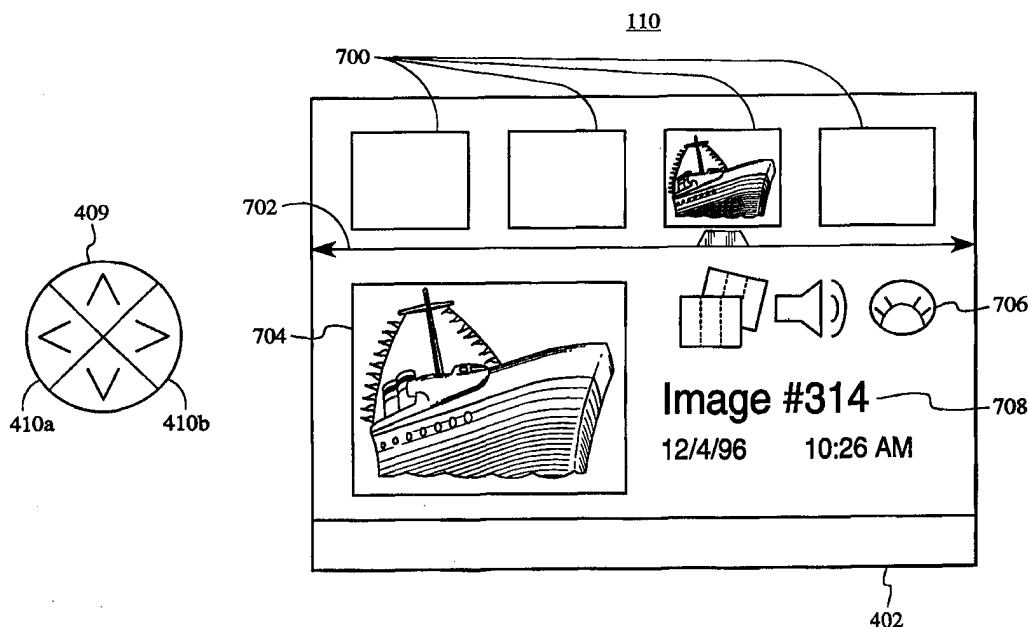

INTERNATIONAL APPLICATION PUBLISHED UNDER THE PATENT COOPERATION TREATY (PCT)

<p>(51) International Patent Classification <sup>6</sup> : <b>H04N 5/222</b></p>	<p><b>A1</b></p>	<p>(11) International Publication Number: <b>WO 98/51073</b> (43) International Publication Date: 12 November 1998 (12.11.98)</p>
<p>(21) International Application Number: PCT/US98/08558 (22) International Filing Date: 28 April 1998 (28.04.98) (30) Priority Data: 08/851,667 5 May 1997 (05.05.97) US (71) Applicant: FLASHPOINT TECHNOLOGY, INC. [US/US]; 152 North Third Street #800, San Jose, CA 95112 (US). (72) Inventors: ANDERSON, Eric, C.; 931 Brentwood Drive, San Jose, CA 95129 (US). SAYLOR, Steve; 3405 White Oak Court, Morgan Hill, CA 95037 (US). MANDER, Amanda, R.; 844 Richardson Court, Palo Alto, CA 94303 (US). (74) Agents: SAWYER, Joseph, A., Jr. et al.; Sawyer &amp; Associates, P.O. Box 51418, Palo Alto, CA 94303 (US).</p>		<p>(81) Designated States: AU, CA, CN, IL, JP, KR, MX, European patent (AT, BE, CH, CY, DE, DK, ES, FI, FR, GB, GR, IE, IT, LU, MC, NL, PT, SE).  <b>Published</b> <i>With international search report. Before the expiration of the time limit for amending the claims and to be republished in the event of the receipt of amendments.</i></p>

(54) Title: A DIGITAL CAMERA WITH MULTIPLE OPERATING MODE



(57) Abstract

The digital camera (110) includes a first button (410) and a second button (411) for interacting with the multiple operating modes. The method and apparatus include mapping an aligned set of mode-specific items in the display (402) to the orientation of the first button. After the mode-specific items are displayed, the user scrolls from one mode-specific item to the next in the aligned set by pressing the first button and the display indicates which of the mode-specific items is a currently active item becomes the active item, additional information corresponding to the currently active item is displayed in the display in a location offset from the active item in a direction of orientation corresponding to that of the second button.

**FOR THE PURPOSES OF INFORMATION ONLY**

Codes used to identify States party to the PCT on the front pages of pamphlets publishing international applications under the PCT.

AL	Albania	ES	Spain	LS	Lesotho	SI	Slovenia
AM	Armenia	FI	Finland	LT	Lithuania	SK	Slovakia
AT	Austria	FR	France	LU	Luxembourg	SN	Senegal
AU	Australia	GA	Gabon	LV	Latvia	SZ	Swaziland
AZ	Azerbaijan	GB	United Kingdom	MC	Monaco	TD	Chad
BA	Bosnia and Herzegovina	GE	Georgia	MD	Republic of Moldova	TG	Togo
BB	Barbados	GH	Ghana	MG	Madagascar	TJ	Tajikistan
BE	Belgium	GN	Guinea	MK	The former Yugoslav Republic of Macedonia	TM	Turkmenistan
BF	Burkina Faso	GR	Greece			TR	Turkey
BG	Bulgaria	HU	Hungary	ML	Mali	TT	Trinidad and Tobago
BJ	Benin	IE	Ireland	MN	Mongolia	UA	Ukraine
BR	Brazil	IL	Israel	MR	Mauritania	UG	Uganda
BY	Belarus	IS	Iceland	MW	Malawi	US	United States of America
CA	Canada	IT	Italy	MX	Mexico	UZ	Uzbekistan
CF	Central African Republic	JP	Japan	NE	Niger	VN	Viet Nam
CG	Congo	KE	Kenya	NL	Netherlands	YU	Yugoslavia
CH	Switzerland	KG	Kyrgyzstan	NO	Norway	ZW	Zimbabwe
CI	Côte d'Ivoire	KP	Democratic People's Republic of Korea	NZ	New Zealand		
CM	Cameroon			PL	Poland		
CN	China	KR	Republic of Korea	PT	Portugal		
CU	Cuba	KZ	Kazakstan	RO	Romania		
CZ	Czech Republic	LC	Saint Lucia	RU	Russian Federation		
DE	Germany	LI	Liechtenstein	SD	Sudan		
DK	Denmark	LK	Sri Lanka	SE	Sweden		
EE	Estonia	LR	Liberia	SG	Singapore		

## A DIGITAL CAMERA WITH MULTIPLE OPERATING MODE

### 5        **FIELD OF THE INVENTION**

The present invention relates generally to digital cameras, and more particularly to a method and apparatus for integrating a digital camera user interface across multiple operating modes.

### 10       **BACKGROUND OF THE INVENTION**

Most digital cameras today are similar in size to and behave like conventional point-and-shoot cameras. Unlike conventional cameras, however, most digital cameras store digital images in an internal flash memory or on external memory cards, and some are equipped with a liquid-crystal display (LCD) screen on the back of the camera. Through the use of the LCD, most digital cameras operate in two modes, record and play, although some only have a record mode. In record mode, the LCD is used as a viewfinder in which the user may view an object or scene before taking a picture. In play mode, the LCD is used as a playback screen for allowing the user to review previously captured images either individually or in arrays of four, nine, or sixteen images.

Digital camera user interfaces typically include a number of buttons or switches for setting the camera into one of the two modes and for navigating between images in play mode. One type of camera, for instance, includes two navigation buttons labeled "-" and "+", a mode button, a display button, a zoom button and a delete button. Play mode for this camera begins with a default screen displaying a full-sized individual image. Other images stored in the camera may then be displayed in a backward or forward sequence by pressing the "-" and "+" navigation buttons, respectively. Pressing the mode button during play mode causes four images to be displayed in a 2x2 array, and pressing the mode button again causes nine images to be displayed in a 3x3 array. The user can then "page" through screens of image arrays by pressing the navigation buttons, or the user can move from image to image in the arrays

by first pressing the display button and then traversing across the images in the rows of the arrays using the navigation buttons. The user may have the full-sized image displayed of a chosen image by pressing the zoom button or can delete the image by pressing the delete button.

5           Although digital cameras that have both a record mode and a play mode are more versatile than digital cameras having only the record mode, two mode digital cameras suffer from several disadvantages associated with the camera's user interface. One disadvantage is that having only two modes means that either the camera only has a limited number of functions, or that  
10           several functions must be accessed in play mode since the record mode only has one function, capturing images. The disadvantages of having several functions in one mode is that the functions may have to be accessed through multiple levels of navigation screens, which complicates the operability of the camera.

15           Another disadvantage of conventional cameras is that the operation of user interface is non-intuitive, especially for the novice user. The user interface is non-intuitive because the operation of the user interface across different modes and/or navigation screens is inconsistent. Accessing most features in the two mode camera described above, for instance, requires that the user  
20           press the keys of the interface in a certain sequence. Each of these key sequences may be different depending on which play-mode navigation screen is displayed, the navigation screen showing individual images or the navigation screen showing arrays of images. For example, the function of the display button changes when the navigation screens change, and in some situations  
25           where the display button has been depressed, the mode button either becomes inoperable or the functionality of mode button becomes mutually exclusive with the functionality of the zoom button. Furthermore, because each navigation screen has a different key sequence, it is not obvious to the user how to exit that screen or how to choose a particular function. Thus, this type  
30           of user interface requires that the user memorize a different key sequence for each navigation screen before being able to effectively operate the camera.

A further disadvantage of conventional digital-camera user-interfaces is

that the camera is capable of displaying only the images themselves, or a combination of an image and its image number. The user interface is either incapable of delivering further information regarding displayed images and the camera features, or accessing such information requires the user to enter another non-intuitive and complicated key sequence.

Accordingly, what is needed is an improved user interface for a multi-mode digital camera. The present invention addresses such a need.

### SUMMARY OF THE INVENTION

The present invention provides a method and system for integrating a user interface across multiple operating modes of a digital camera wherein mode-specific items are displayed on a display when the digital camera is placed into a particular operating mode. The digital camera includes a first and a second navigation button for interacting with the operating modes, where the first navigation button has a first orientation and the second navigation button has a second orientation. The method includes the step of mapping an aligned set of mode-specific items in the display to the orientation of the first navigation button. After the mode-specific items are displayed, the user scrolls from one mode-specific item to the next in the aligned set by pressing the first navigation button, and the display indicates which of the mode-specific items is a currently active item. After a mode-specific item becomes the active item, additional information is displayed corresponding to the currently active item in the display in a location that is offset from the active item in a direction of orientation corresponding to that of the second button. In certain modes, the additional information includes a list of information items that is displayed in an alignment corresponding to the orientation of the second button, wherein the user can scroll through the list of information items using the second navigation button.

According to the method and apparatus disclosed herein, the digital camera is provided with more than two modes wherein the user can navigate, manipulate, and view camera contents using a consistent and intuitive spatial navigation technique. Providing more than one mode in which the user can view images and camera contents reduces the complexity of the user interface,

and the spatial navigation frees the user from entering long key sequences. The user interface also automatically displays context sensitive information regarding the active item, which reduces the input required from the user and thereby increases the ease of use and operation of the digital camera.

5

## **BRIEF DESCRIPTION OF THE DRAWINGS**

FIG. 1 is a block diagram of a digital camera that operates in accordance with the present invention.

10

FIG. 2 is a block diagram of the preferred embodiment for the imaging device of FIG. 1.

FIG. 3 is a block diagram of the preferred embodiment for the computer of FIG. 1.

FIG. 4 is a memory map showing the preferred embodiment of the Dynamic Random-Access-Memory (DRAM).

15

FIGS. 5A and 5B are diagrams depicting the back and top view, respectively, of a digital camera.

FIG. 6 is a flow chart illustrating the process of integrating a user interface across multiple operating modes of a digital camera according to the present invention.

20

FIG. 7 is a block diagram illustrating a preferred embodiment of the present invention in which the alignment of the mode-specific items are mapped to the orientation of the horizontal navigation buttons.

25

FIG. 8 is a block diagram of the user interface illustrating that when the mode-specific items are displayed horizontally, information corresponding to an active item is displayed vertically offset from the row of mode-specific items.

FIG. 9 is a diagram illustrating the operation and appearance of the integrated user interface during review mode in accordance with a preferred embodiment of the present invention.

30

FIGS. 10A and 10B are diagrams illustrating the operation and appearance of the integrated user interface during menu mode in accordance with a preferred embodiment of the present invention.

FIGS. 11A and 11B are diagrams illustrating the operation and

appearance of the integrated user interface during capture mode in accordance with a preferred embodiment of the present invention.

## DETAILED DESCRIPTION OF THE INVENTION

5           The present invention relates to an improvement in user interfaces of digital imaging devices, including digital cameras. The following description is presented to enable one of ordinary skill in the art to make and use the invention and is provided in the context of a patent application and its requirements. Various modifications to the preferred embodiment will be readily apparent to those skilled in the art and the generic principles herein  
10           may be applied to other embodiments. Thus, the present invention is not intended to be limited to the embodiment shown but is to be accorded the widest scope consistent with the principles and features described herein.

          The present invention is a method and apparatus for integrating a  
15           digital camera user interface across multiple operating modes. According to the present invention, a method and system is provided for providing a digital camera with more than two modes and for providing a consistent and intuitive user interface across the multiple modes. The operation of the user interface across the multiple modes includes a user controlled horizontal interaction  
20           following by a reply from the camera of a vertical display of additional information in response to the user controlled horizontal interaction.

          A digital camera architecture has been disclosed in co-pending U.S. Patent Application Serial No. 08/666,241, entitled "A System And Method For Using A Unified Memory Architecture To Implement A Digital Camera Device,"  
25           filed on June 20, 1996. The Applicant hereby incorporates the co-pending application by reference, and reproduces portions of that application herein with reference to FIGS. 1-3 for convenience.

          Referring now to FIG. 1, a block diagram of a digital camera 110 is shown according to the present invention. Camera 110 preferably comprises  
30           an imaging device 114, a system bus 116 and a computer 118. Imaging device 114 is optically coupled to an object 112 and electrically coupled via system bus 116 to computer 118. Once a photographer has focused imaging

device 114 on object 112 and, using a capture button or some other means, instructed camera 110 to capture an image of object 112, computer 118 commands imaging device 114 via system bus 116 to capture raw image data representing object 112. The captured raw image data is transferred over  
5 system bus 116 to computer 118 which performs various image processing functions on the image data before storing it in its internal memory. System bus 116 also passes various status and control signals between imaging device 114 and computer 118.

Referring now to FIG. 2, a block diagram of the preferred embodiment of  
10 imaging device 114 is shown. Imaging device 114 preferably comprises a lens 220 having an iris, a filter 222, an image sensor 224, a timing generator 226, an analog signal processor (ASP) 228, an analog-to-digital (A/D) converter 230, an interface 232, and one or more motors 234.

U.S. Patent No. 5,496,106, entitled "A System and Method For  
15 Generating a Contrast Overlay as a Focus Assist for an Imaging Device," is incorporated herein by reference and provides a detailed discussion of the preferred elements of imaging device 114. Briefly, imaging device 114 captures an image of object 112 via reflected light impacting image sensor 224 along optical path 236. Image sensor 224, which is preferably a charged  
20 coupled device (CCD), responsively generates a set of raw image data in CCD format representing the captured image 112. The raw image data is then routed through ASP 228, A/D converter 230 and interface 232. Interface 232 has outputs for controlling ASP 228, motors 234 and timing generator 226. From interface 232, the raw image data passes over system bus 116 to  
25 computer 118.

Referring now to FIG. 3, a block diagram of the preferred embodiment  
for computer 118 is shown. System bus 116 provides connection paths  
between imaging device 114, an optional power manager 342, central  
processing unit (CPU) 344, dynamic random-access memory (DRAM) 346,  
30 input/output interface (I/O) 348, non-volatile memory 350, and  
buffers/connector 352. Removable memory 354 connects to system bus 116  
via buffers/connector 352. Alternately, camera 110 may be implemented



without removable memory 354 or buffers/connector 352.

Power manager 342 communicates via line 366 with power supply 356 and coordinates power management operations for camera 110. CPU 344 typically includes a conventional processor device for controlling the operation of camera 110. In the preferred embodiment, CPU 344 is capable of concurrently running multiple software routines to control the various processes of camera 110 within a multi-threading environment. DRAM 346 is a contiguous block of dynamic memory which may be selectively allocated to various storage functions. LCD controller 390 accesses DRAM 346 and transfers processed image data to LCD screen 402 for display.

I/O 348 is an interface device allowing communications to and from computer 118. For example, I/O 348 permits an external host computer (not shown) to connect to and communicate with computer 118. I/O 348 also interfaces with a plurality of buttons and/or dials 404, and an optional status LCD 406, which in addition to the LCD screen 402, are the hardware elements of the camera's user interface 408.

Non-volatile memory 350, which may typically comprise a conventional read-only memory or flash memory, stores a set of computer-readable program instructions to control the operation of camera 110. Removable memory 354 serves as an additional image data storage area and is preferably a non-volatile device, readily removable and replaceable by a camera 110 user via buffers/connector 352. Thus, a user who possesses several removable memories 354 may replace a full removable memory 354 with an empty removable memory 354 to effectively expand the picture-taking capacity of camera 110. In the preferred embodiment of the present invention, removable memory 354 is typically implemented using a flash disk.

Power supply 356 supplies operating power to the various components of camera 110. In the preferred embodiment, power supply 356 provides operating power to a main power bus 362 and also to a secondary power bus 364. The main power bus 362 provides power to imaging device 114, I/O 348, non-volatile memory 350 and removable memory 354. The secondary power bus 364 provides power to power manager 342, CPU 344 and DRAM 346.

Power supply 356 is connected to main batteries 358 and also to backup batteries 360. In the preferred embodiment, a camera 110 user may also connect power supply 356 to an external power source. During normal operation of power supply 356, the main batteries 358 provide operating power to power supply 356 which then provides the operating power to camera 110 via both main power bus 362 and secondary power bus 364. During a power failure mode in which the main batteries 358 have failed (when their output voltage has fallen below a minimum operational voltage level) the backup batteries 360 provide operating power to power supply 356 which then provides the operating power only to the secondary power bus 364 of camera 110.

Referring now to FIG. 4A, a memory map showing the preferred embodiment of dynamic random-access-memory (DRAM) 346 is shown. In the preferred embodiment, DRAM 346 includes RAM disk 532, a system area 534, and working memory 530.

RAM disk 532 is a memory area used for storing raw and compressed image data and typically is organized in a "sectored" format similar to that of conventional hard disk drives. In the preferred embodiment, RAM disk 532 uses a well-known and standardized file system to permit external host computer systems, via I/O 348, to readily recognize and access the data stored on RAM disk 532. System area 534 typically stores data regarding system errors (for example, why a system shutdown occurred) for use by CPU 344 upon a restart of computer 118.

Working memory 530 includes various stacks, data structures and variables used by CPU 344 while executing the software routines used within computer 118. Working memory 530 also includes input buffers 538 for initially storing sets of raw image data received from imaging device 114 for image conversion, and frame buffers 536 for storing data for display on the LCD screen 402.

In a preferred embodiment, the conversion process is performed by a live view generation program, which is stored in non-volatile memory 350 and executed on CPU 344. However, the conversion process can also be

implemented using hardware. Referring again to FIG. 3, during the execution of the live view generation program (not shown), the CPU 344 takes the raw image data from the input buffers 538 in CCD format and performs color space conversion on the data. The conversions process performs gamma correction and converts the raw CCD data into either a RGB or YCC color format which is compatible with the LCD screen 402. After the conversion, CPU 344 stores the image data in the frame buffers 536. The LCD controller 390 then transfers the processed image data from the frame buffers to the LCD screen 402 (via an optional analog converter) for display.

Referring now to FIG. 4B, the contents of input buffers 538 and the frame buffers 536 are shown. In a preferred embodiment, both the input buffers 538 and the frame buffers 536 utilize two separate buffers, called ping-pong buffers, to improve the display speed of the digital camera and to prevent the tearing of the image in the display 402. As shown, input buffers 538 include an input buffer A and an input buffer B, and frame buffers 536 include a frame buffer A and a frame buffer B.

The input buffers A and B alternate between an input cycle and a processing cycle. During the input cycle, the input buffers 538 are filled with raw image data from the image device 114, and during the processing cycle, CPU 344 processes the raw data and transmits the processed data to the frame buffers 536. More specifically, while input buffer A is filling with image data, the data from input buffer B is processed and transmitted to frame buffer B. At the same time, previously processed data in frame buffer A is output to the LCD screen 402 for display. While input buffer B is filling with image data, the data from input buffer A is processed and transmitted to frame buffer A. At the same time, previously processed data in frame buffer B is output to the LCD screen 402 for display.

According to the present invention, the flexible architecture of the digital camera is used to provide and integrated camera user interface. More specifically, the present invention provides a method and system for integrating a digital-camera user-interface across multiple operating modes of the digital camera.

FIGS. 5A and 5B are diagrams depicting the hardware components of the camera's 110 user interface 408. FIG. 5A is back view of the camera 110 showing the LCD screen 402, a four-way navigation control button 409, an overlay button 412, a menu button 414, and a set of programmable soft keys 416. FIG. 5B is a top view of the camera 110 showing a shutter button 418, and a mode dial 420. The camera may optionally include status LCD 406, status LCD scroll and select buttons 422 and 424, a sound record button 426, and zoom-in, zoom-out buttons 426a and 426b.

In one aspect of the present invention, the user interface 408 includes several different operating modes for supporting various camera functions. However, the modes relevant to this description are review mode, menu mode, and capture (record) mode. In review mode, the camera 100 supports the actions of reviewing camera contents, editing and sorting images, and printing and transferring images. In menu mode, the camera 100 allows the user to manipulate camera settings and to edit and organize captured images. In capture mode, the camera 100 supports the actions of preparing to capture an image, and capturing an image through the use of either the LCD screen 402 or the status LCD 406.

The user switches between the review, menu, and capture modes, using the mode dial 420. When the camera is placed into a particular mode, that mode's default screen appears in the LCD screen 402 in which a set of mode-specific items, such as images, icons, and text, are displayed. According to the present invention, the user may navigate through and access the contents and features of multiple camera modes using a consistent and intuitive user interface. Throughout various operating modes, the user interface includes a user controlled horizontal interaction following by a reply from the camera of a vertical display of information. Because the user interacts with the camera in each of various camera modes using the hardware buttons in a similar manner, as described herein, the learnability and usability of the camera are enhanced.

Referring now to FIG. 6, a flow chart is shown illustrating the process of integrating a user interface across multiple operating modes of a digital camera in accordance with the present invention. Referring to both FIGS. 5A, and 6,

the process begins by providing the user interface with at least two sets of navigation buttons in step 600. As shown in FIG. 5A, in a preferred embodiment of the present invention, the four-way navigation control button 409 provides the user interface with four buttons; left/right buttons 410a and 410b, which have a horizontal orientation, and up/down buttons 411a and 411b, which have a vertical orientation. In accordance with the present invention, the user uses the four way controller 409 in each of the various camera modes as a global navigational device in a way that provides the user with intuitive spatial orientation when navigating through the modes, as explained further below.

Referring again to FIG. 6, after the camera is placed into a particular mode, a set of mode-specific items are aligned in the LCD screen 402 so that the alignment of the mode-specific items maps to the natural spatial orientations of one set of navigation buttons on the four way controller in step 602.

FIG. 7 is a block diagram illustrating a preferred embodiment of the present invention in which the alignment of the mode-specific items 430 are mapped to the orientation of the horizontal navigation buttons 410a and 410b. As shown, mapping the alignment of the mode-specific items 430 to the orientation of the horizontal navigation buttons 410a and 410b causes the mode-specific items 430 to be displayed in a row(s) across the LCD screen 402. Rather than mapping the alignment of the mode-specific items 430 to the orientation of the horizontal navigation buttons 410, the mode-specific items 430 may also be mapped to the orientation of the vertical navigation buttons 411a and 411b. This would cause the mode-specific items to be displayed in a column in the LCD screen 402. Additionally, the alignment of the mode-specific items 430 may be mapped to other navigation button orientations (e.g. a diagonal orientation) if so desired.

Referring again to FIG. 6, after the mode-specific items 430 are displayed, the user can scroll or navigate from one mode-specific item 430 to the next by pressing the mapped navigation buttons in step 604. In FIG. 7 for example, pressing navigation button 410b causes a right scrolling action, and

pressing navigation button 410A causes a left scrolling action. As the user scrolls through the mode-specific items 430, the camera displays an indication 432 of which one of the mode-specific items 430 is a currently active item 434 in step 606. This indication 432 may take the form of a highlight, a stationary or moving pointer, the active item 432 itself may blink, or a different type of mode-specific item may be shown to indicate an active/inactive status.

After a particular mode-specific item 430 has become the active item 434, additional information 436 corresponding to the active item is displayed in the LCD screen 402 in a location offset from the active item 434 in a direction mapped to the orientation of the second set of navigation buttons in step 608.

FIG. 8 is a block diagram of the user interface illustrating that when the mode-specific items 430 are displayed horizontally, the information 436 corresponding to the active item 434 is displayed in an area of the LCD screen 402 that is vertically offset 438 from the horizontal row of mode-specific items, and that the direction of offset 438 is parallel to the orientation of the vertical navigation buttons 411a and 411b.

According to the present invention, throughout the various operating modes of the camera, the integrated user interface maintains an interaction model in which the user scrolls horizontally to select an active mode-specific item, followed by a vertical display of additional information in the LCD screen 402 relating to the active item. And in certain modes, the additional information includes a list of information items that is displayed in an alignment corresponding to the orientation of the vertical navigation buttons 411a and 411b, wherein the user can scroll through the list of information items using those buttons.

By mapping both the modes of navigation and the display of mode information to the orientation of the navigation buttons 410 and 411 of the four way controller, the user essentially only has to learn one major mechanism for interacting with the multiple modes of the digital camera. That is, since the user interface interacts with each of the camera modes using only the four-way controller 409, the integrated user interface of the present invention significantly reduces the amount of key sequences the user must memorize in

order to operate the camera. The preferred implementations of the review mode, the menu mode, and the capture mode are described below to further explain the integrated user interface of the present invention.

Referring now to FIG. 9, a diagram illustrating the operation and appearance of the integrated user interface during review mode is shown in accordance with a preferred embodiment of the present invention. Moving the mode dial 420 (FIG. 5B) to access the review mode enables the user to view all the images in the camera along with specific attributes associated with each of the images.

The mode-specific items displayed across the LCD screen 402 in review mode are thumbnail images 700 that represent small-sized versions of the captured images. The thumbnails 700 are intended to serve as navigational aides rather than accurate representations of their images. As a result, the thumbnails 700 are cropped to a square size (50x50 pixels). A stationary selection arrow line 702 is used as both a navigational aid and to indicate which thumbnail is the currently active image.

In a preferred embodiment, the review screen layout displays four thumbnails 700 at a time and is based on a filmstrip metaphor which allows users to quickly move forward and backward among pictures chronologically. The user may navigate through the series of displayed thumbnails 700 in the LCD screen 402 using the four-way navigation control button 409. When the user holds down the left/right buttons 410, the thumbnails 700 are scrolled-off the LCD screen 402 and replaced by new thumbnails 700 representing other captured images to provide for fast browsing of the camera contents. When there are more than four images in the camera, the selection arrow line 702 displays arrow heads to indicate movement in that direction is possible with the left/right navigation buttons 410. As the user presses the navigation buttons 410 and the thumbnails 700 scroll across the LCD screen 402, the thumbnail 700 that is positioned over a notch in the selection arrow line 702 is considered the active image.

When a thumbnail 700 becomes the active image, additional information corresponding to that image is automatically displayed vertically offset from the

row of thumbnails 700 in the LCD screen 402. In a preferred embodiment, the additional information includes a large thumbnail 704 showing a larger view of the active thumbnail, and image information comprising an icon bar 706 and text 708. The icon bar may display several icons indicating the media types associated with the active image, such as whether the image is a still, a time lapse, or a burst image, whether sound is attached to the image, and a category for the image. The displayed text 708 may include a specification of the name or number of the image, and the date and time the image was captured.

Referring now to FIGS. 10A and 10B, diagrams illustrating the operation and appearance of the integrated user interface during menu mode are shown in accordance with a preferred embodiment of the present invention. Menu mode may be accessed during other camera modes by pressing the menu button 414 or the soft keys 416 (see FIG. 5B) on the camera interface; and pressing the menu button 414 again exits the mode. Similar to the review mode, the menu mode is divided into horizontal and vertical elements, and is also capable of supporting various levels of sub menus.

The menu-mode is capable of displaying multiple levels of navigation in the menu structure. In the first level of menus, the mode-specific items displayed in a row across the LCD screen 402 are graphical icons 720 representing menu categories for camera and image settings. In accordance with the integrated user interface of the present invention, the user may first select a menu category by navigating horizontally across the LCD screen 402 using the horizontal navigation control button 410, and then select a menu item by navigating vertically in the display using the vertical navigation control buttons 411.

When navigating horizontally from icon to icon 720 in the LCD screen 402, arrows on selection arrow line 702 indicate to the user which direction they can navigate. In the example shown in FIGS. 10A and 10B, the right arrow underneath the icon row indicates that the user can only scroll right and that more icons 720 are available past the fourth icon 720 in the row. In a preferred embodiment, the icons are stationary in the LCD screen 402, and as



the user presses the left/right buttons 410, each icon 720 in turn becomes the active icon. If the fourth icon 720 is active and the user presses the right navigation button 410b, then the display would "page" to reveal the next set of icons 720. In an alternative embodiment, the icons 720 scroll on and off the LCD screen 402 as the user presses the left/right buttons 410.

When an icon becomes active, the icon 720 is highlighted, a text label 722 for the icon is displayed under the icon 720, and a list of menu items corresponding to camera features is displayed below the text label 722 in an alignment mapped to the orientation of the up/down buttons 411. FIG. 10A shows an example menu displayed below the text menu corresponding the first icon in the row. After a menu is displayed, the user can then vertically scroll through the list of menu items by pressing the up/down buttons 411, causing a highlight to move up and down the feature list. FIG. 10B illustrates the result of the user scrolling to the second icon in the row, which causes the menu for that icon to be displayed.

In a preferred embodiment, sub-levels of menus may be displayed if necessary by pressing other buttons on the camera, such as a soft key 416. When a secondary level of menus is available, text such as "edit", "next", or "more" may appear above a soft key 416, as shown. By pressing the soft key 416 under this text, a secondary menu will be displayed in the same fashion as the first level. Pressing the "edit" soft key again in the second level menu, brings up another level, and so on.

Referring now to FIGS. 11A and 11B, diagrams illustrating the operation and appearance of the integrated user interface during capture mode are shown in accordance with a preferred embodiment of the present invention. Because most of color LCD technology in use today may have disadvantages in terms of power consumption and viewability, the present invention includes the status LCD 406 in the user interface 110 to act as a supplementary capture interface to compensate for the restrictions of the LCD screen 402. The optional status LCD 406 provides image capture and feature setting capability without using the color LCD screen 402.

Similar to the modes described above, the status LCD 406 in capture

mode is divided into horizontal and vertical elements. Referring to FIG. 11A, the horizontal mode-specific items displayed across the status LCD 406 are icons 730 that enable the user to set the following preferred set of features; image capture type, flash, image compression level, exposure/focus lock, and self timer. In accordance with the integrated user interface, the user navigates through the status LCD 406 using a horizontal scroll button 422 and a vertical select button 424, although the four-way controller 409 may optionally be used in an alternate embodiment.

To navigate the status LCD 406, the user presses horizontal scroll button 422 to activate individual icons across the top row with each press. Active icons are preferably identified by blinking on and off. To modify the current setting associated with an active icon 730 the user presses the vertical select button 424 to toggle the setting to the desired state. To reinforce the meaning of the active icon state, an alphanumeric display 732 is used to spell out the current setting of the active icon. Each time the user presses the vertical select button 424, the state of the active icon state changes, and the alphanumeric display 732 displays text corresponding to that state.

FIG. 11B is diagram illustrating the possible icon 730 states for the status LCD 406 in a preferred embodiment of the present invention. The first icon 730 in the icon row represents the image capture type settings, and the possible states shown from top to bottom correspond to burst, still, or time-lapse image capture type. The second icon 730 represents the flash setting, and the possible states shown are on, auto, and off. The third icon 730 represents the image compression level, and the possible states shown are good, better, and best. The fourth icon 730 represents the exposure/focus lock setting, and the possible states shown are auto exposure (AE) lock, auto focus (AF) lock, AF/AE active, and AF/AE lock. And the last icon 730 in the icon row represents the setting for the self timer, and the possible states shown are off and on.

A method and system for integrating a digital camera user interface across multiple operating modes has been disclosed. Throughout the various operating modes of the camera, the integrated user interface maintains an

interaction model in which the user scrolls horizontally to select a mode-specific item, followed by a vertical display of additional information in the LCD screen relating to that selected item. Using the integrated user interface of the present invention, the user can navigate, manipulate, and view camera  
5 contents using a consistent and intuitive spatial navigation technique that frees the user from entering long key sequences, and thereby increases the ease of use and operation of the digital camera.

Although the present invention has been described in accordance with the embodiments shown, one of ordinary skill in the art will readily recognize that  
10 there could be variations to the embodiments and those variations would be within the spirit and scope of the present invention. For example, the integrated user interface also applies to cameras having only two modes, but that have multiple navigation screens within the "play mode" Accordingly, many modifications may be made by one of ordinary skill in the art without departing  
15 from the spirit and scope of the appended claims.

## CLAIMS

What is claimed is:

5           1       A method for integrating a user interface across multiple operating modes of a digital camera having a display, wherein when the digital camera is placed into each one of the multiple operating modes, mode-specific items corresponding to that mode are displayed on the display, the digital camera including a first button and a second button for interacting with the multiple  
10           operating modes, the first button having a first orientation and the second button having a second orientation, the method comprising the steps of:

          a)       mapping an aligned set of mode-specific items in the display to the orientation of the first button to create a mapped navigation button;  
          b)       scrolling from one mode-specific item to the next in the aligned set by  
15           pressing the mapped navigation button wherein the display indicates which of the mode-specific items is a currently active item; and  
          c)       displaying additional information corresponding to the currently active item in the display in a location that is offset from the active item in a direction of orientation corresponding to that of the second button.

20

2       The method as in claim 1 wherein when the camera is placed into a first mode, the additional information includes a list of information items, the method further including the steps of:

          c1)     displaying the list of information items in an alignment  
25           corresponding to the orientation of the second button; and  
          d)       scrolling through the list of information items by pressing the second button.

3       The method as in claim 2 wherein step b) further includes the step of:

30           b1)    providing the first button with left and a right navigation buttons having a horizontal orientation.

4 The method as in claim 3 wherein step c) further includes the step of:  
c2) providing the second button with up and down navigation buttons  
having a vertical orientation.

5 5 The method as in claim 4 further including the step of displaying a set of  
menu icons as the mode-specific items while in the first operating mode.

6 The method as in claim 5 further including the step of pressing the down  
navigation button to scroll through the list of information items corresponding to  
10 the currently active item.

7 The method as in claim 4 further including the step of providing a second  
operating mode wherein when the digital camera is placed into the second  
operating mode, a set of thumbnail images corresponding to captured images  
15 are displayed as the mode-specific items.

8 The method as in claim 7 further including the step of displaying a large  
thumbnail as part of the additional information.

20 9 The method as in claim 4 further including the step of providing a third  
operating mode wherein when the digital camera is placed into the third  
operating mode, a set of icons representing camera features are displayed as  
the mode-specific items.

25 10 The method as in claims 9 further including the step of changing a  
particular one of the camera features by pressing one of the up and down  
navigation buttons to change a state of the corresponding icon.

30 11 A digital camera having an integrated user interface; comprising:  
an image device for capturing image data;  
a memory coupled to the imaging device for storing the image data as  
captured images;

a display;  
a first set of navigation buttons having a first orientation;  
a second set of navigation buttons having a second orientation;  
multiple operating modes for supporting a plurality of digital camera functions;  
and

a processor coupled to the image device, the memory, the display and to the first and second set of navigation buttons for controlling operation of the digital camera and the multiple operating modes, wherein the processor includes,

means responsive to the digital camera being placed into at least two of the multiple operating modes for displaying a set of mode-specific items in the display in an alignment that is mapped to the orientation of the first set of navigation buttons,

means for scrolling from one mode-specific item to the next in the set in response to a user pressing the first set of navigation buttons, wherein an indication in the display indicates which of the mode-specific items is a currently active item, and

means for displaying additional information corresponding to the currently active item in the display in a location that is offset from the active item in a direction of orientation corresponding to that of the second set of navigation buttons.

12 The digital camera of claim 11 wherein when the digital camera is placed into a first operating mode, the additional information includes a list of information items, wherein the processor further includes,

means for displaying the list of information items in an alignment corresponding to the orientation of the second set of navigation buttons; and

means for scrolling through the list of information items in response to the user pressing the second navigation button.

13 The digital camera as in claim 12 wherein the first set of navigation buttons have a horizontal orientation and the second set of navigation buttons

have a vertical orientation.

14 The digital camera as in claim 13 wherein in the first operating mode the menu-specific items comprise icons representing menu categories.

5

15 The digital camera as in claim 14 wherein as the user presses the first set of navigation buttons to scroll through the set of icons, each of the icons is highlighted, and becomes an active icon in response to the user pressing one of the second set of navigation buttons.

10

16 The digital camera as in claim 15 wherein when the digital camera is placed into a second operating mode the menu-specific items comprise thumbnails representing captures images.

15

17 The digital camera as in claim 16 wherein when the digital camera is placed into the second operating mode the additional information includes a large thumbnail representing of the currently active item.

20

18 The digital camera as in claim 17 wherein when the digital camera is placed into a third operating mode the menu-specific items comprise icons representing camera feature settings.

25

19 The digital camera as in claim 18 wherein when the digital camera is placed into the third operating mode the additional information includes text representing the feature setting of the currently active item.

30

20 The digital camera as in claim 19 wherein the digital camera further includes a status display wherein when the digital camera is placed into the third operating mode the mode-specific items and the additional information are displayed in the status display.

21 A method for integrating a user interface across multiple operating modes

of a digital imaging device, the digital imaging device including a display, and a navigational device including first and second control buttons for controlling the display, the method comprising the steps of:

- a) placing the digital imaging device into a first operating mode;
- 5 b) displaying a plurality mode-specific items in a horizontal row across the display;
- c) providing a user controlled horizontal interaction whereby the user presses the first control button to horizontally scroll through the plurality mode-specific items in the row, which activates individual mode-specific items with  
10 each press; and
- d) providing a vertical response from the digital imaging device wherein in a position on the display vertically offset from the plurality mode-specific items, the digital imaging device displays an optional combination of graphics and text corresponding to the activated mode-specific item; and
- 15 e) placing the digital imaging device into a second operating mode and repeating steps b) through d), thereby improving ease of use of the digital camera.

22 A method as in claim 21 wherein step b) further includes the step of:

- 20 b1) displaying a plurality of thumbnail images as the mode-specific items.

23 A method as in claim 22 wherein step d) further includes the step of:

- 25 d1) displaying a large thumbnail image corresponding to the activated mode-specific item.

24 A method as in claim 23 wherein step d) further includes the step of:

- d2) displaying text of an image name and date corresponding to the activated mode-specific item.

25 A method as in claim 21 wherein step b) further includes the step of:

- b1) displaying a plurality of icons as the mode-specific items.



26 A method as in claim 25 wherein step d) further includes the step of:  
d1) displaying a text feature list corresponding to the activated mode-specific item.

5 27 A method as in claim 25 wherein step d) further includes the step of:  
d1) displaying text corresponding to a state of the activated mode-specific item.

10 28 A digital camera having an integrated user interface; comprising:  
an image device for capturing image data;  
a memory coupled to the imaging device for storing the image data as captured images;  
a first set of navigation buttons having a first orientation and a second set of navigation buttons having a second orientation for controlling navigation in the display;  
15 a processor coupled to the image device, the memory, the primary display and to the first and second set of navigation buttons for controlling operation of the digital camera including a first operating mode and a second operating mode;  
a primary display coupled to the processor, the primary display being  
20 divided into a first set of elements aligned with the orientation of the first set of navigation buttons and a second element displayed offset from the first set of elements in a direction aligned with the orientation of the second set of navigation buttons, wherein when the camera is in the first operating mode, a user navigates the first set of elements using the first set of navigation buttons and navigates the second element using the second set of navigation buttons;  
25 and  
a status display coupled to the processor, the status display being divided into a third set of elements and a fourth set of elements, wherein the third set of elements is aligned with the orientation of the first set of navigation buttons and  
30 the fourth element is displayed offset from the third set of elements in a direction of orientation corresponding to that of the second set of navigation buttons, wherein when the camera is in the second operating mode, the user navigates

the third set of elements using the first set of navigation buttons and navigates the second element using the second set of navigation buttons, whereby navigation of the second operating mode in the status display is similar to navigation of the first operating mode in the primary display.

5

29 The digital camera as in claim 28 further including a first status control button and a second status control button wherein the user navigates the status display using the first and second status control buttons.

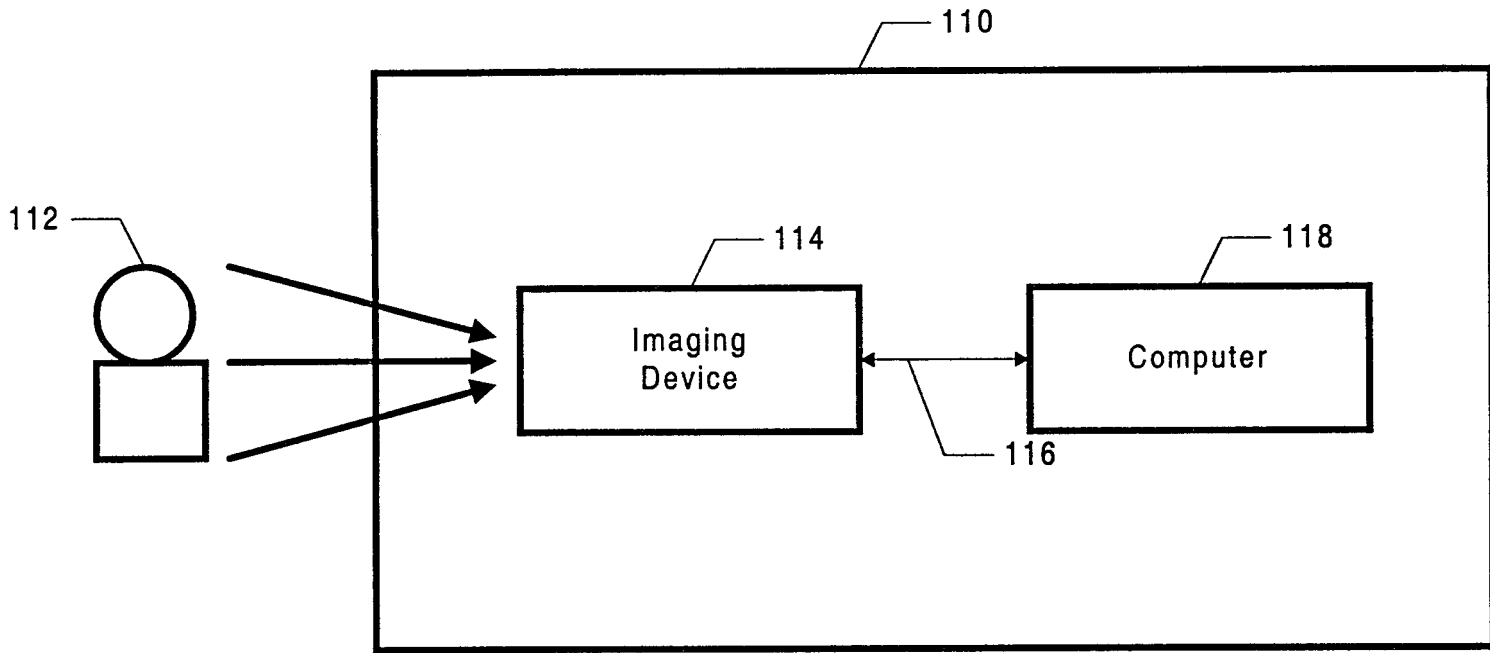

FIG. 1

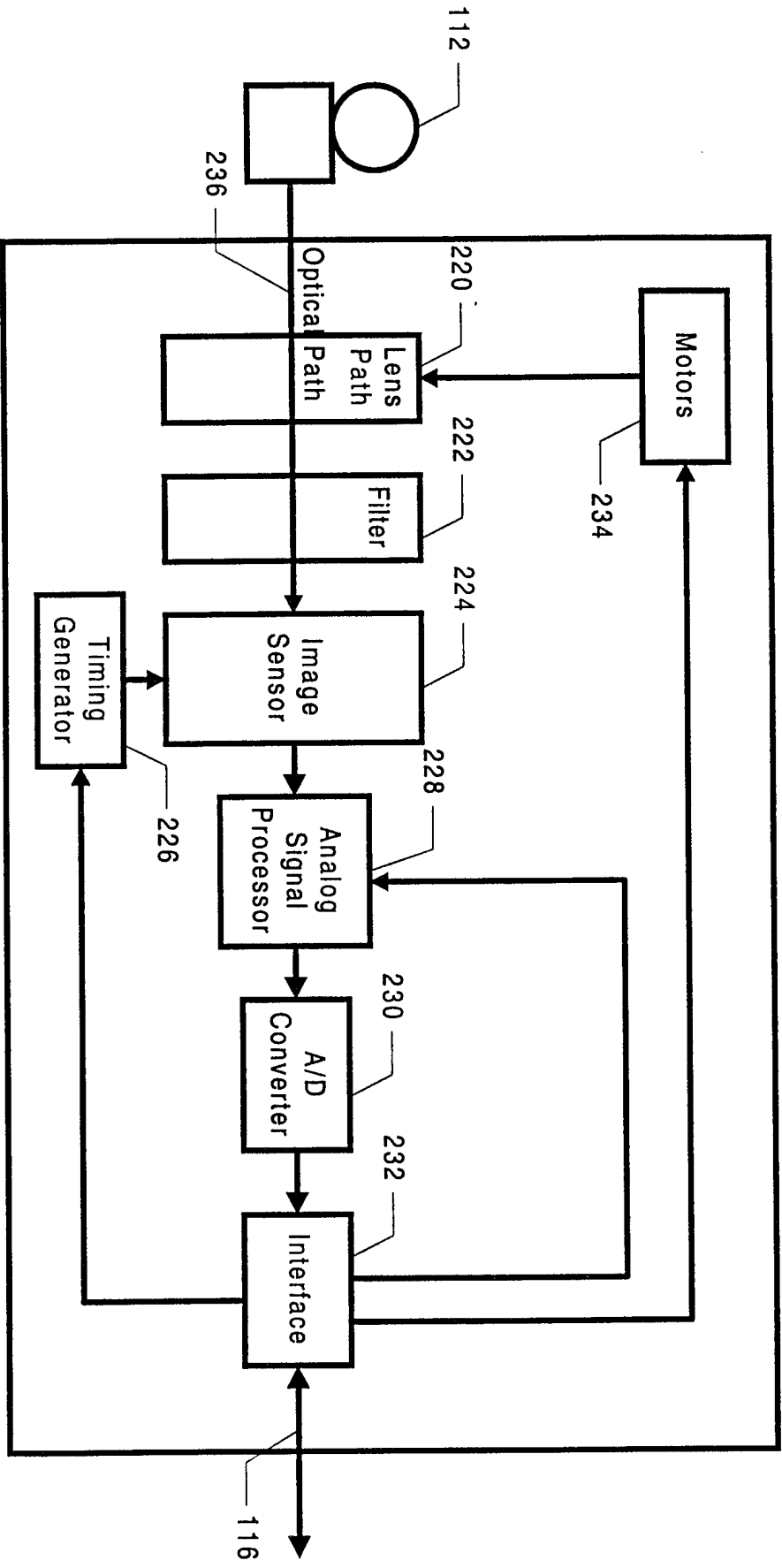
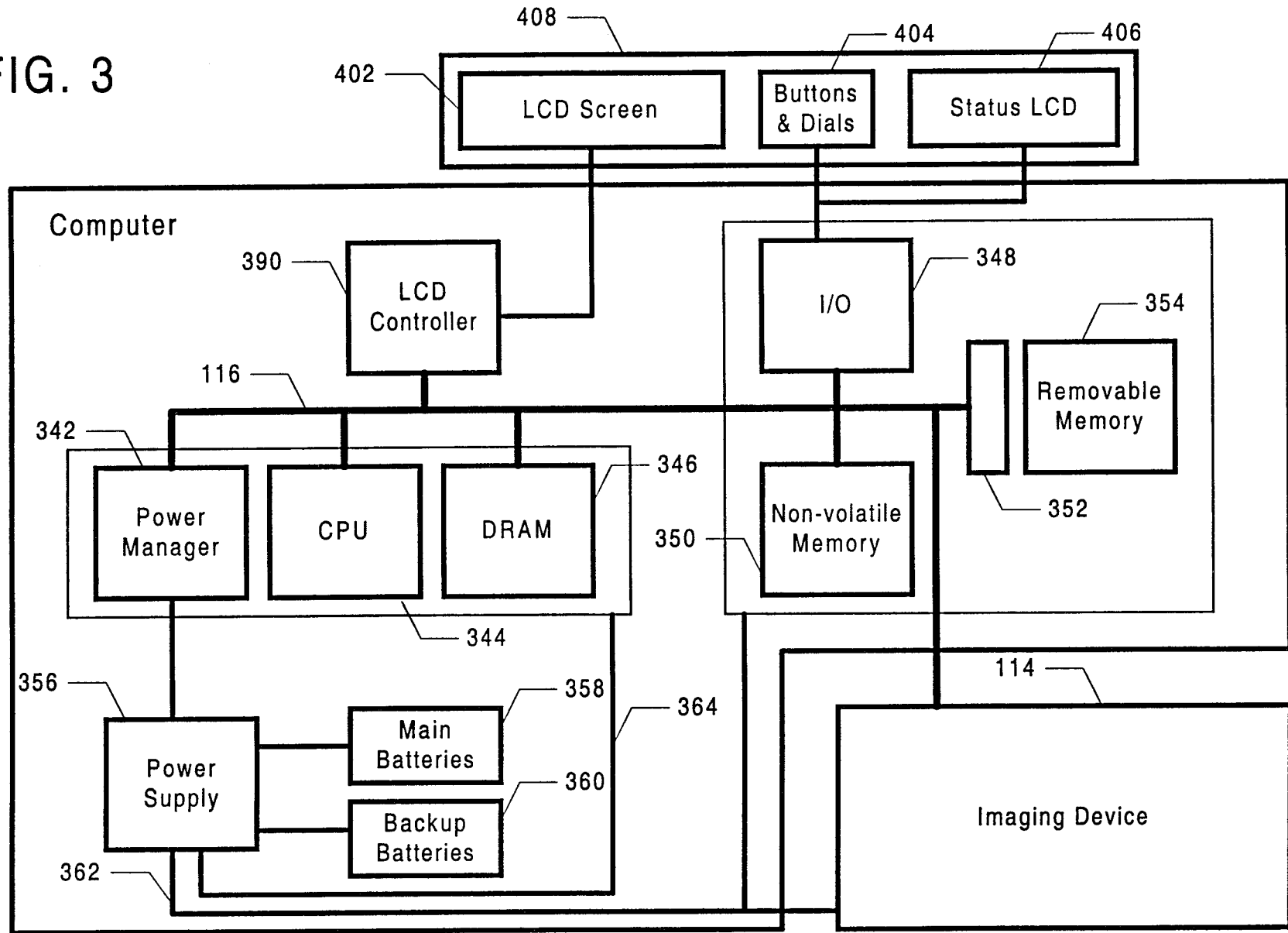

FIG. 2

FIG. 3



346

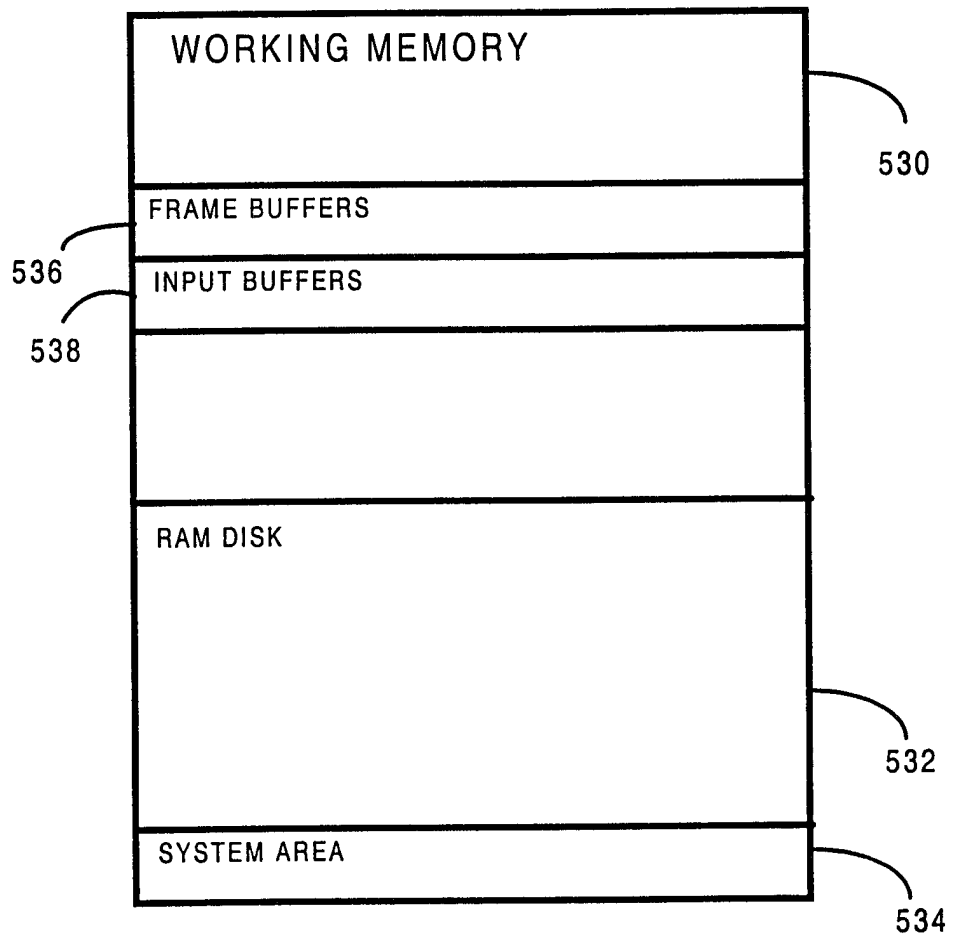

FIG. 4A

408

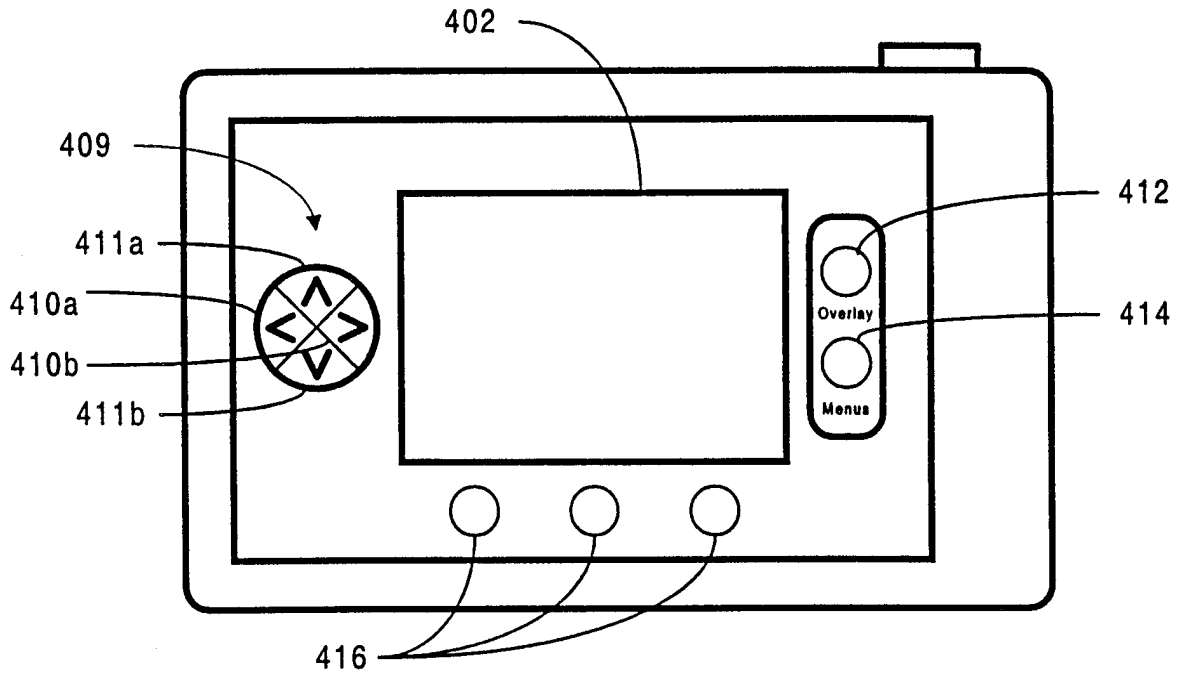

FIG. 5A

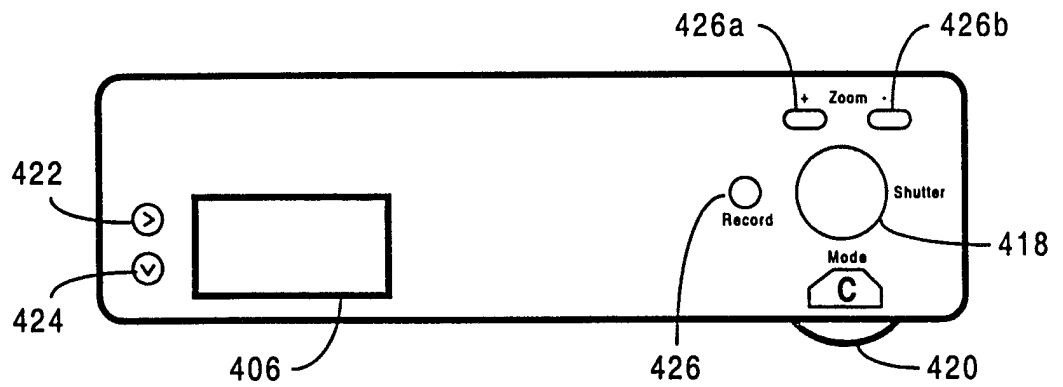

FIG. 5B

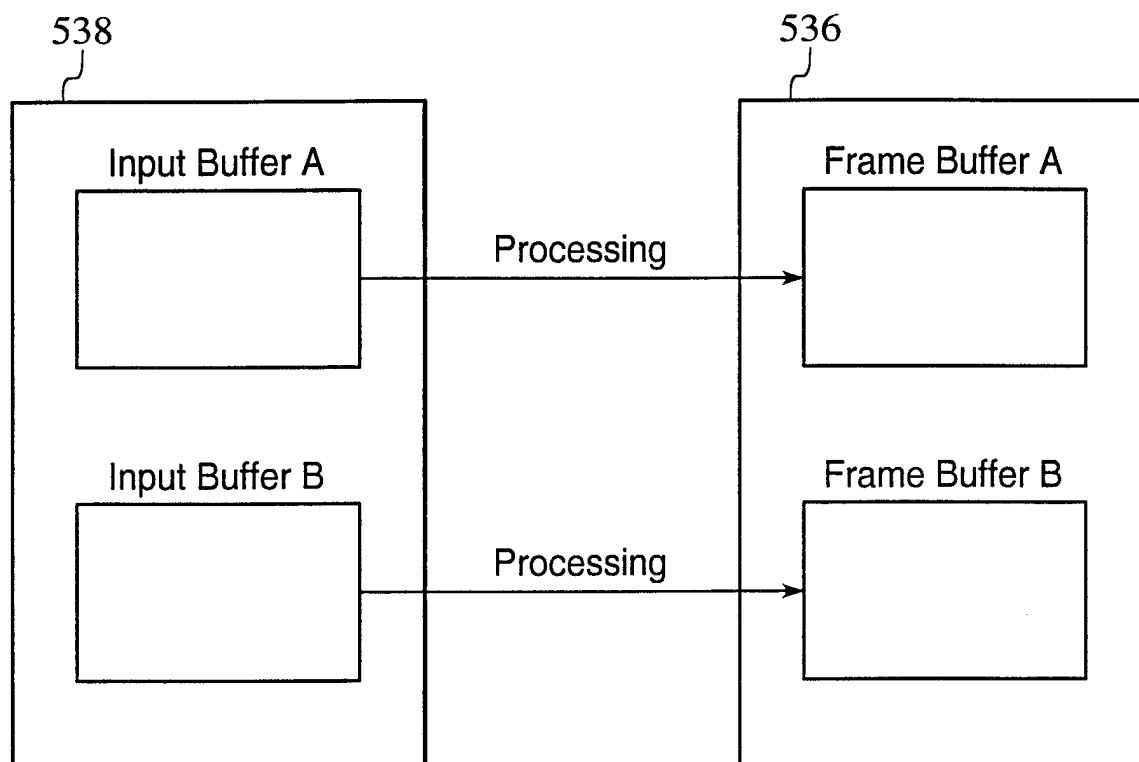

FIG. 4B



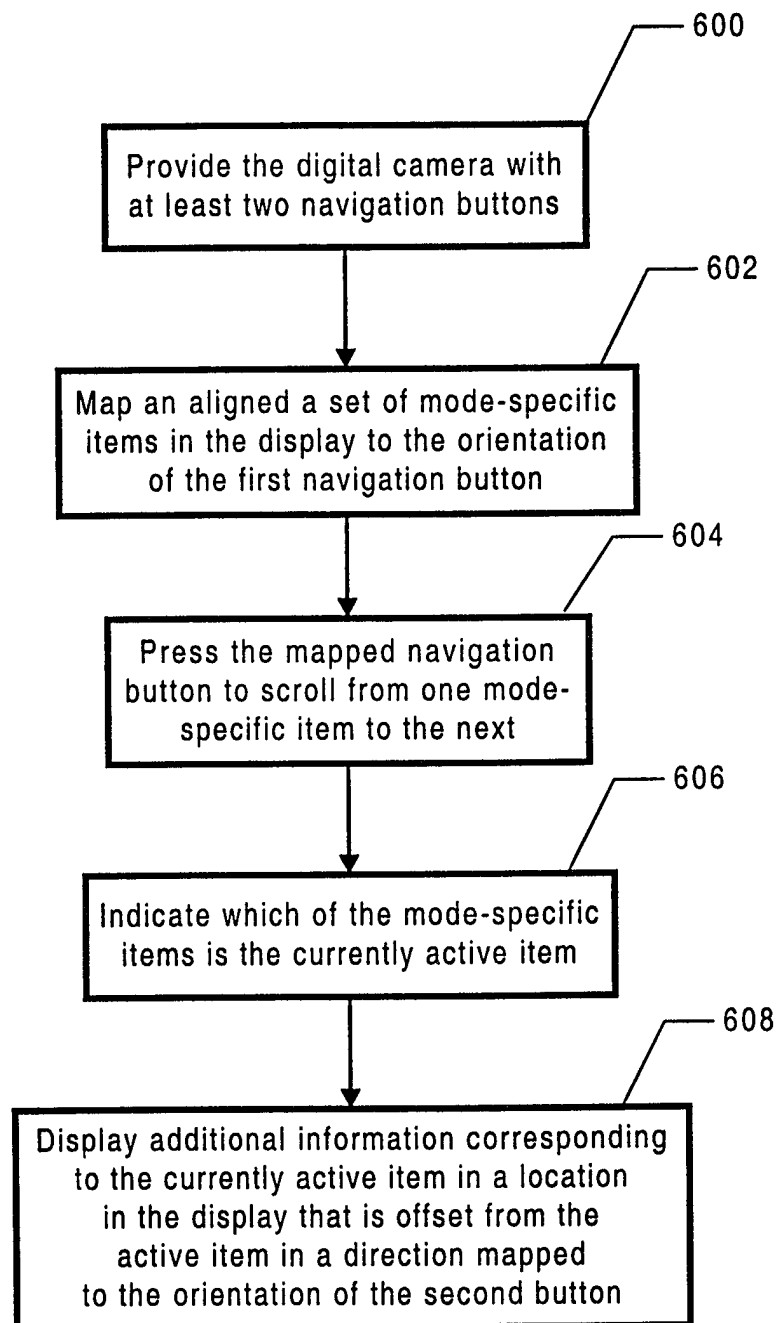

FIG. 6

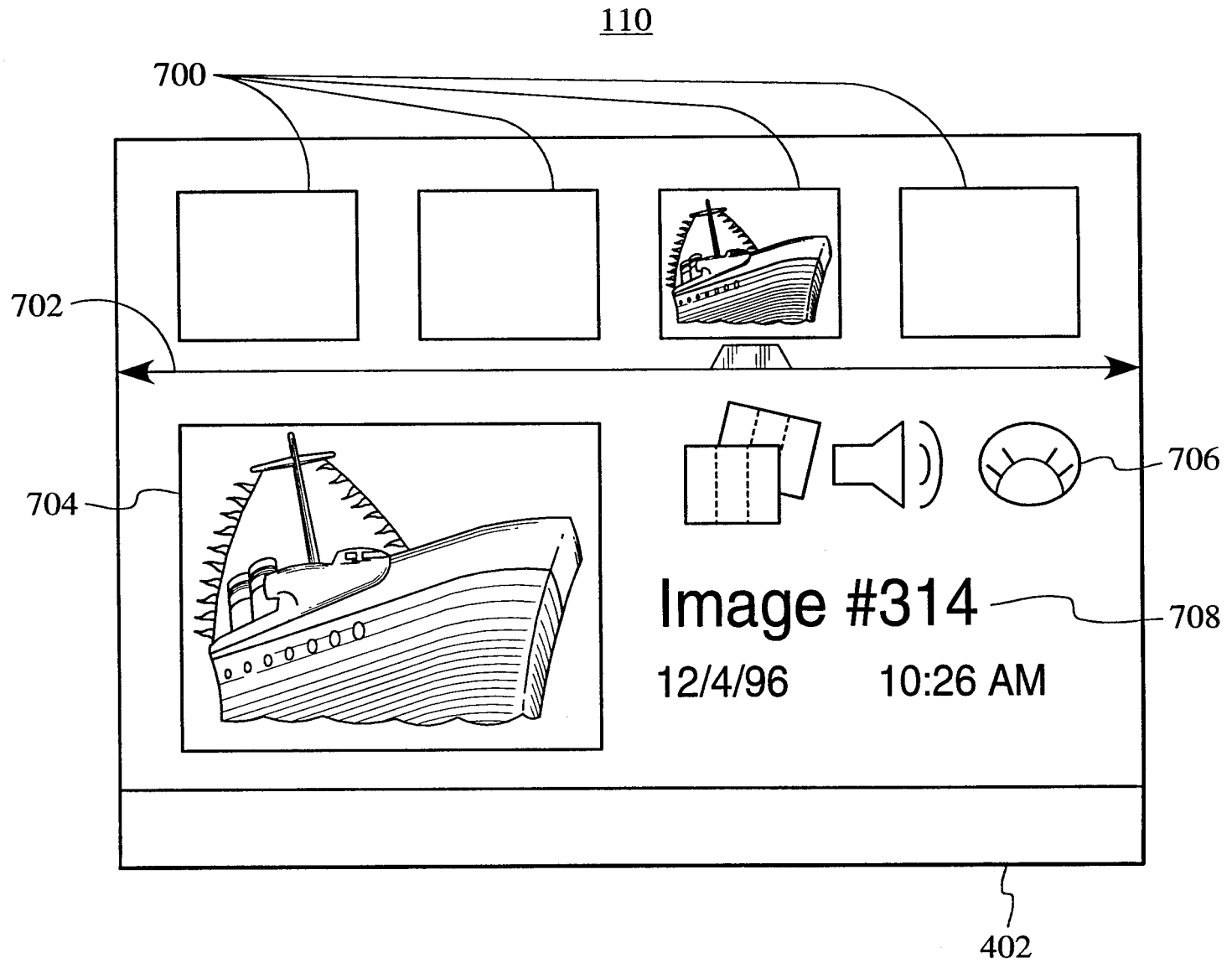
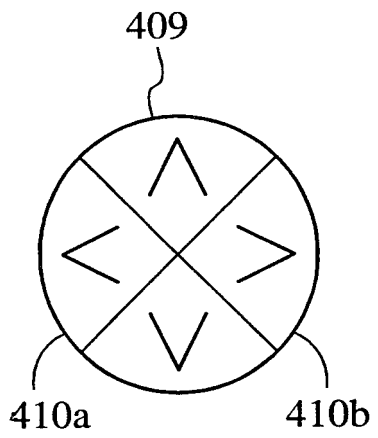

FIG. 9

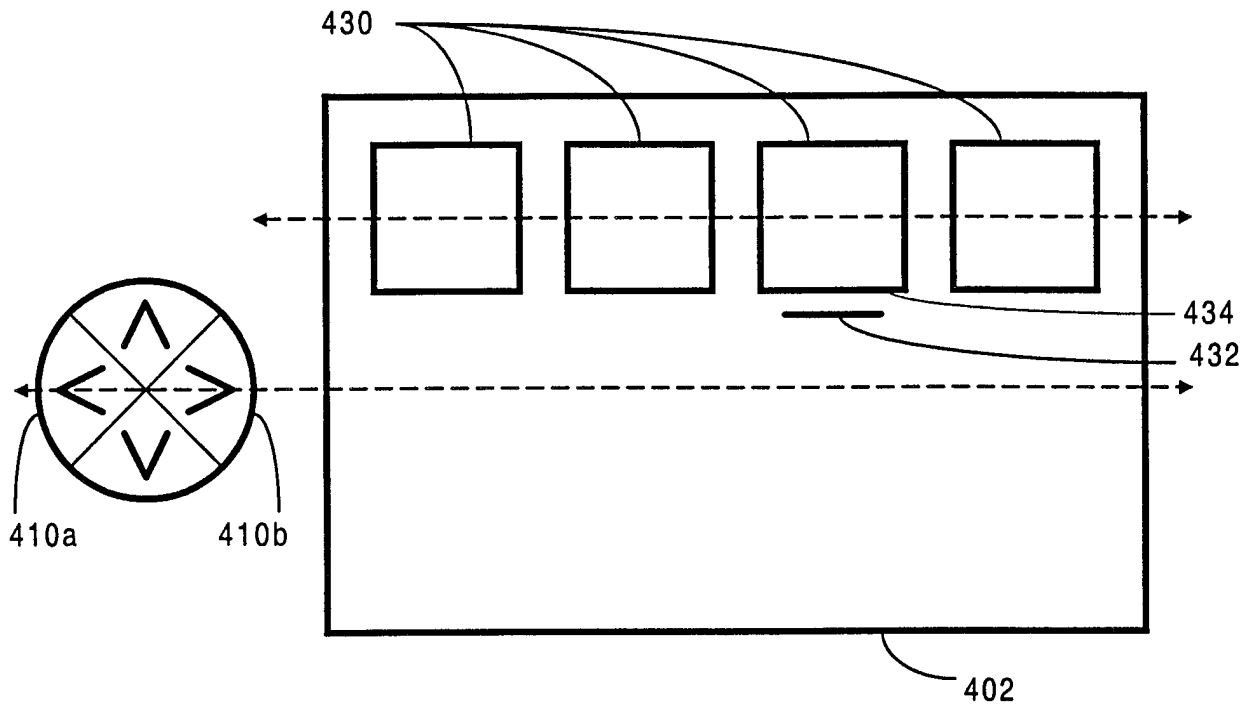

FIG. 7

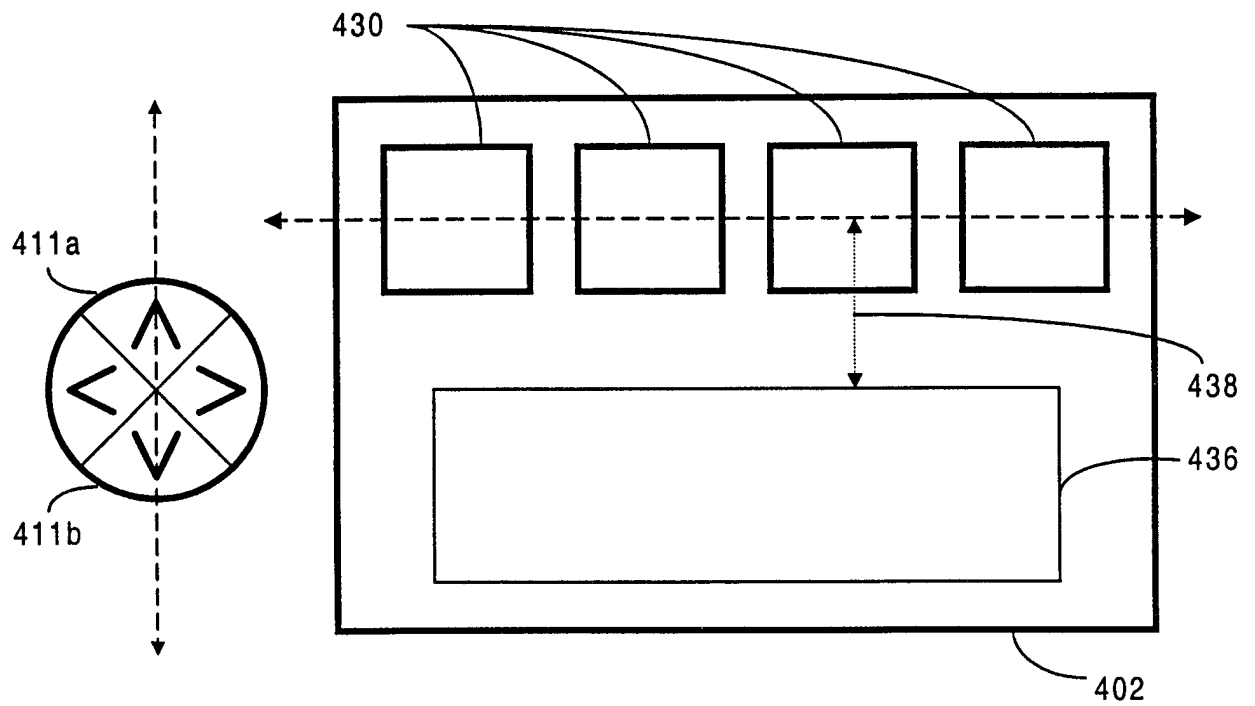

FIG. 8

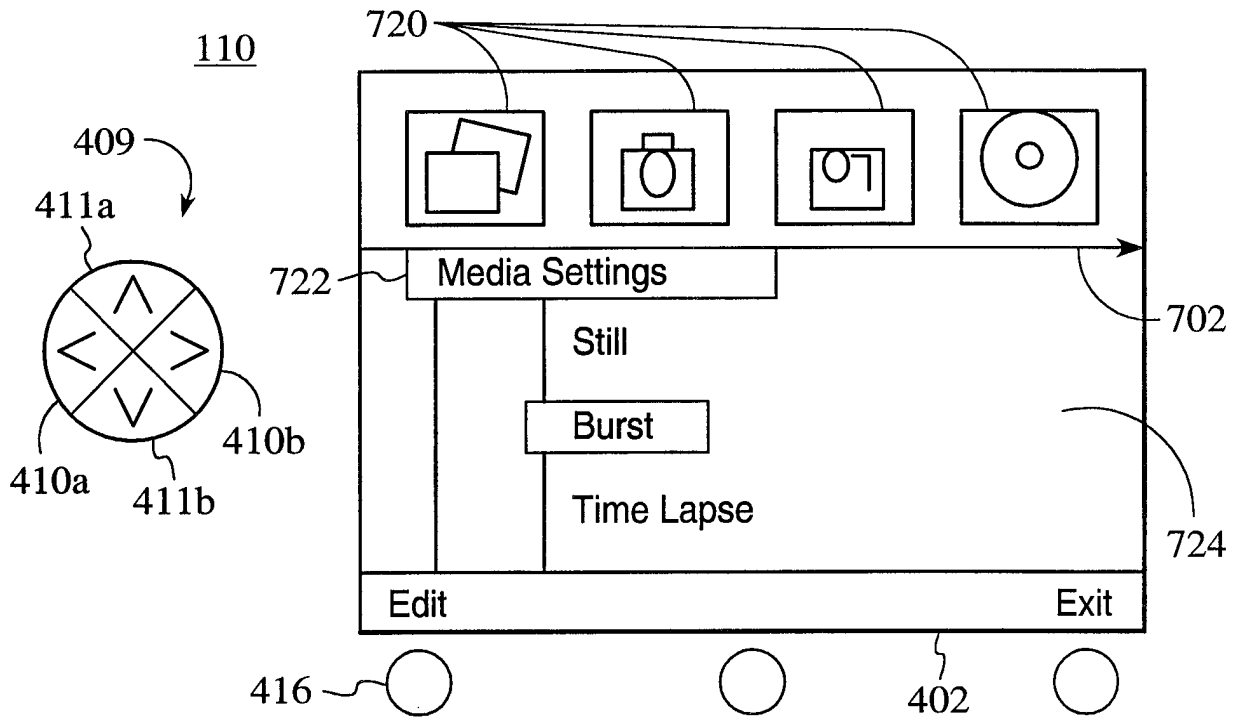

FIG. 10A

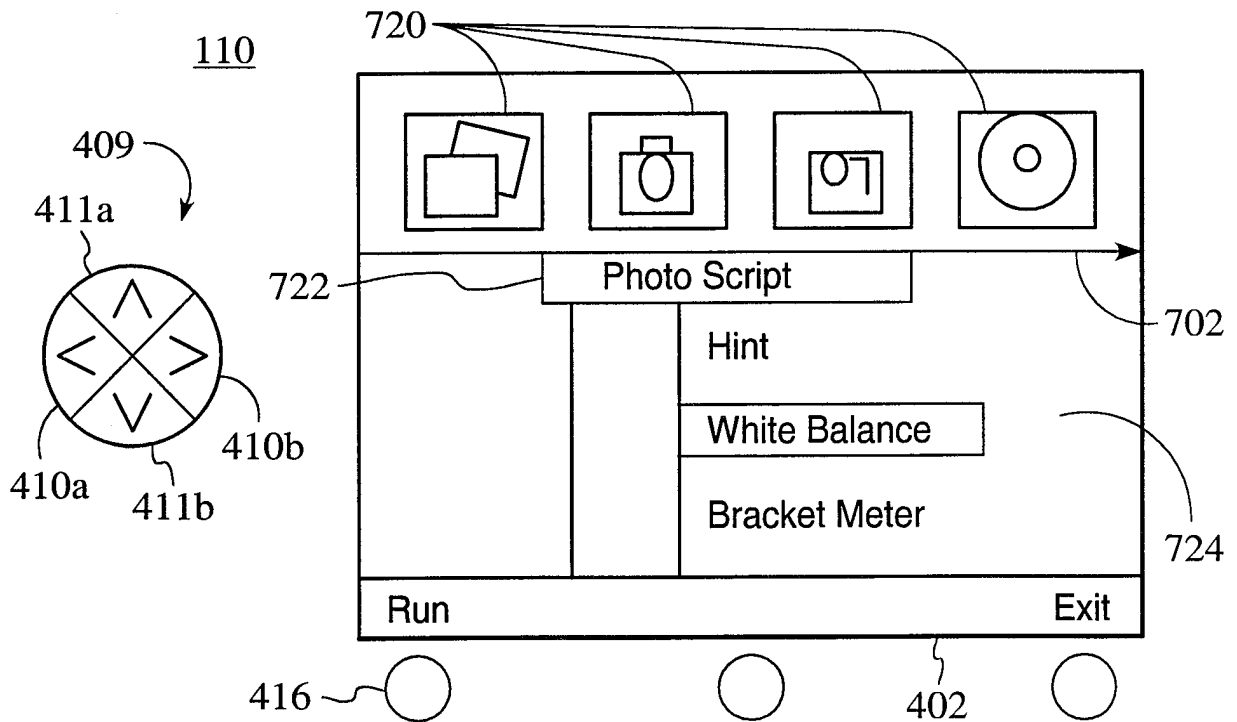

FIG. 10B

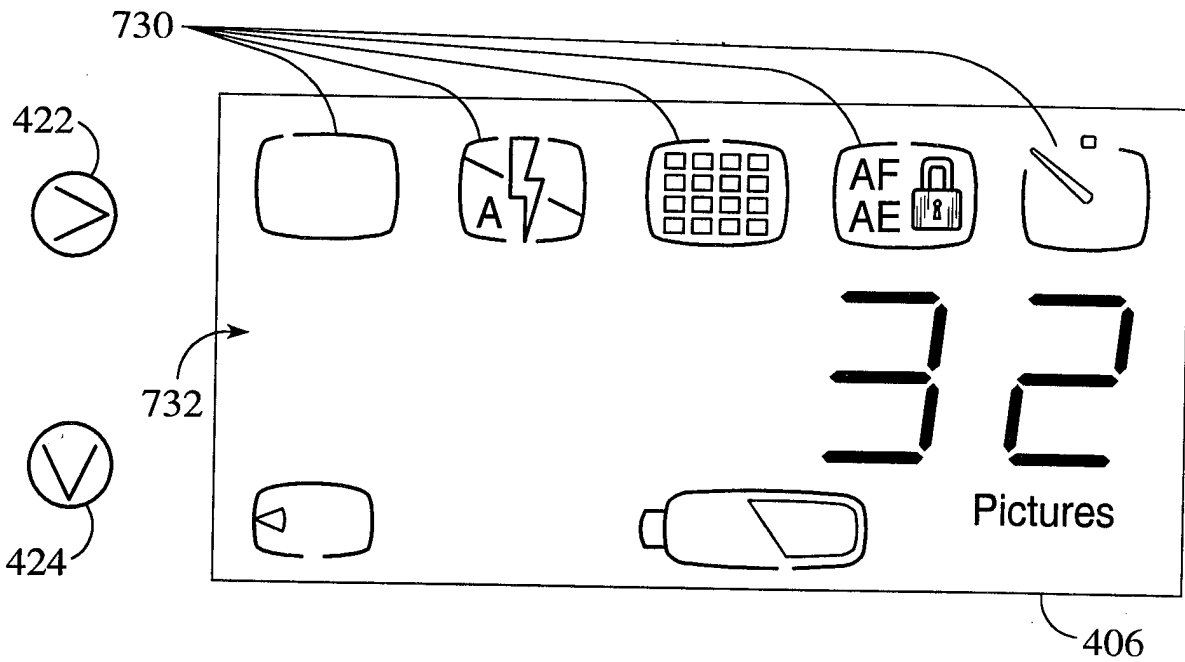

FIG. 11A

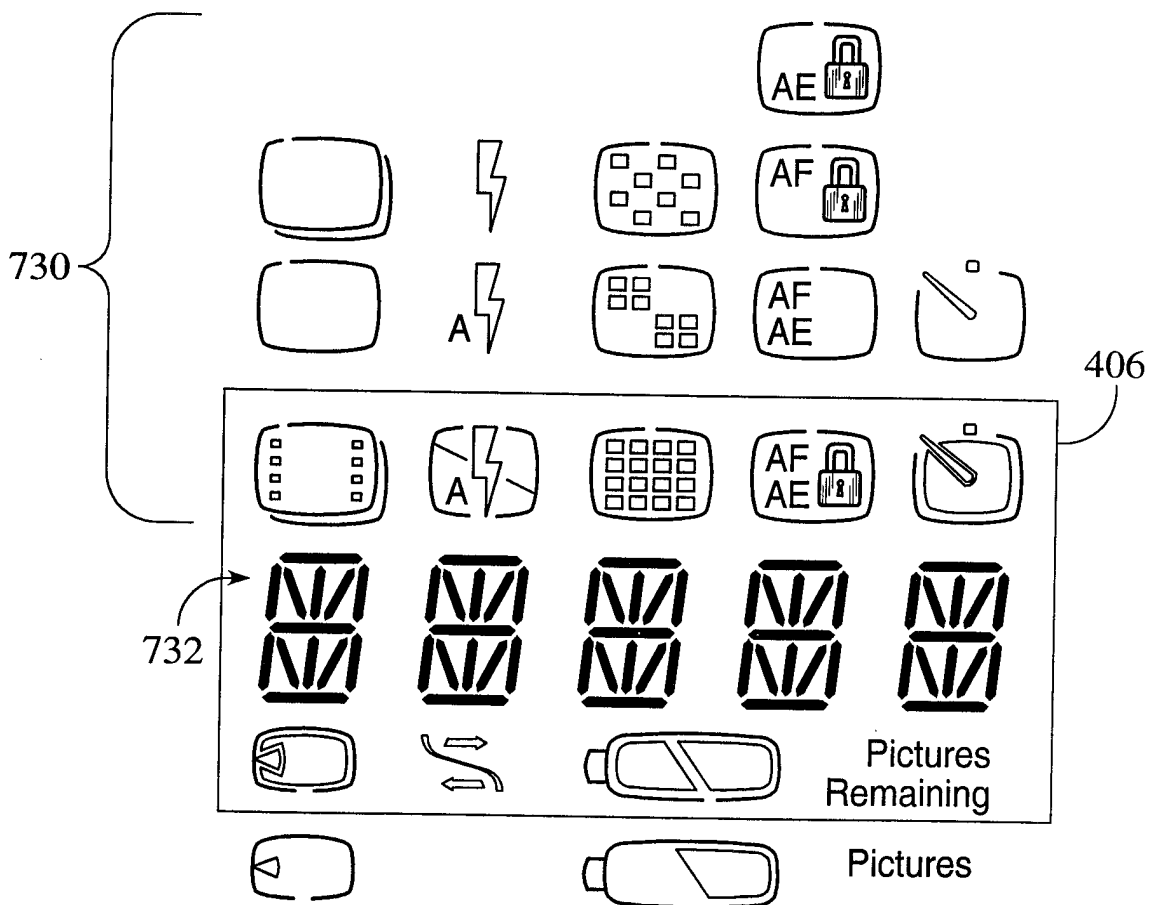

FIG. 11B

INTERNATIONAL SEARCH REPORT

International application No.  
PCT/US98/08558

A. CLASSIFICATION OF SUBJECT MATTER

IPC(6) :HO4N 5/222

US CL : 348/333, 334, 207

According to International Patent Classification (IPC) or to both national classification and IPC

B. FIELDS SEARCHED

Minimum documentation searched (classification system followed by classification symbols)

U.S. : 348/333, 334, 373, 375, 376, 552, 232, 233, 231, 222, 207

Documentation searched other than minimum documentation to the extent that such documents are included in the fields searched

Electronic data base consulted during the international search (name of data base and, where practicable, search terms used)

C. DOCUMENTS CONSIDERED TO BE RELEVANT

Category*	Citation of document, with indication, where appropriate, of the relevant passages	Relevant to claim No.
Y	US 5,473,370 A (MORONAGA et al.) 5 DECEMBER 1995, Figs. 1-12, col. 9, line 20 - col. 25, line 55.	1-29
Y	US 5,237,648 A (MILLS et al.) 17 AUGUST 1993, Figs. 2-7, col. 3, line 5 - col. 8, line 68.	1-2, 11-12, 7, 15, 21-22, 28
Y	US 4,982,291 A (KURAHASHI et al.) 01 JANUARY 1991, Fig. 1, col. 3, line 1-40.	3, 13
Y	US 4,935,809 A (HAYASHI et al.) 19 JUNE 1990, Figs. 17-19, col. 21, line 10 - col. 22, line 35.	8, 17, 23

Further documents are listed in the continuation of Box C.

See patent family annex.

* Special categories of cited documents:	*T* later document published after the international filing date or priority date and not in conflict with the application but cited to understand the principle or theory underlying the invention
*A* document defining the general state of the art which is not considered to be of particular relevance	*X* document of particular relevance; the claimed invention cannot be considered novel or cannot be considered to involve an inventive step when the document is taken alone
*E* earlier document published on or after the international filing date	*Y* document of particular relevance; the claimed invention cannot be considered to involve an inventive step when the document is combined with one or more other such documents, such combination being obvious to a person skilled in the art
*L* document which may throw doubts on priority claim(s) or which is cited to establish the publication date of another citation or other special reason (as specified)	*&* document member of the same patent family
*O* document referring to an oral disclosure, use, exhibition or other means	
*P* document published prior to the international filing date but later than the priority date claimed	

Date of the actual completion of the international search

07 JUNE 1998

Date of mailing of the international search report

07 OCT 1998

Name and mailing address of the ISA/US  
Commissioner of Patents and Trademarks  
Box PCT  
Washington, D.C. 20231

Facsimile No. (703) 305-3230

Authorized officer

WENDY GARBER

Telephone No. 703-305-4929