

No. 649,902.

Patented May 22, 1900.

J. P. BROPHY.
AUTOMATIC LATHE ATTACHMENT.

(Application filed July 17, 1899.)

(No Model.)

3 Sheets—Sheet 1.

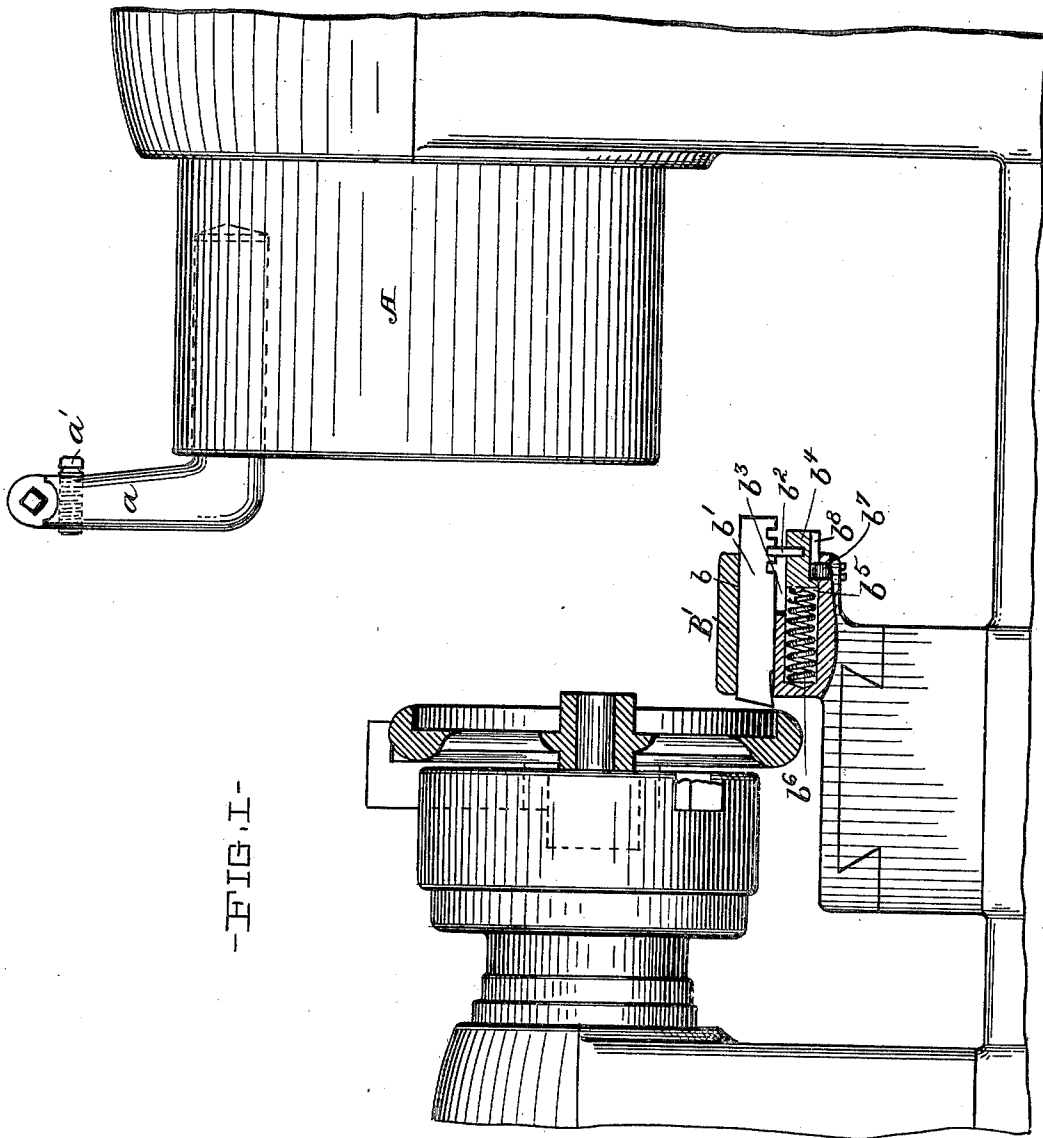

-FIG. I-

Witnesses,
J. C. Turner
A. E. Merkel

Inventor,
J. P. Brophy
By *J. P. Brophy*
J. P. Gay Atty.

No. 649,902.

Patented May 22, 1900.

J. P. BROPHY.
AUTOMATIC LATHE ATTACHMENT.

(Application filed July 17, 1899.)

(No Model.)

3 Sheets—Sheet 2.

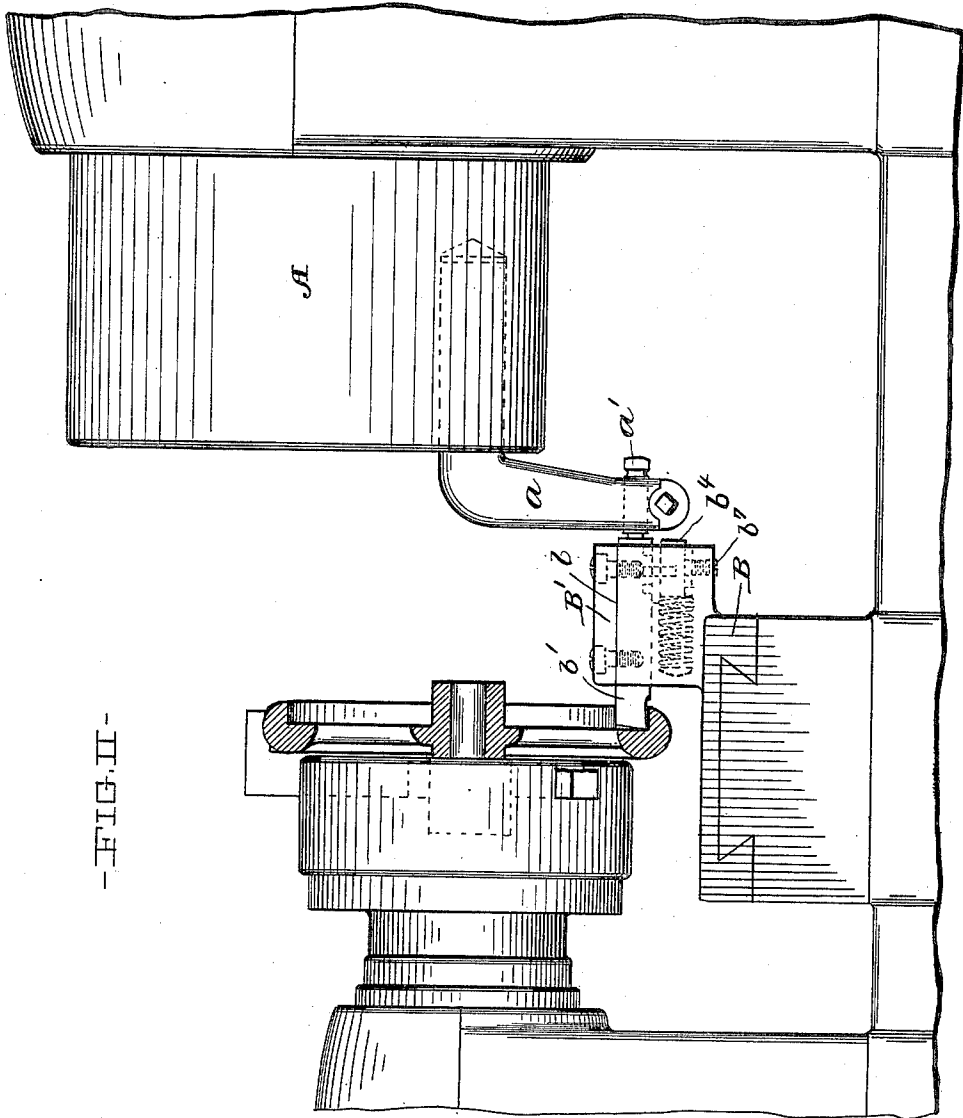

-FIG. II-

Witnesses,

J. C. Turner

A. E. Merrill

Inventor,

J. P. Brophy

By

J. D. Fay
Atty.

No. 649,902.

Patented May 22, 1900.

J. P. BROPHY.
AUTOMATIC LATHE ATTACHMENT.

(Application filed July 17, 1899.)

(No Model.)

3 Sheets—Sheet 3.

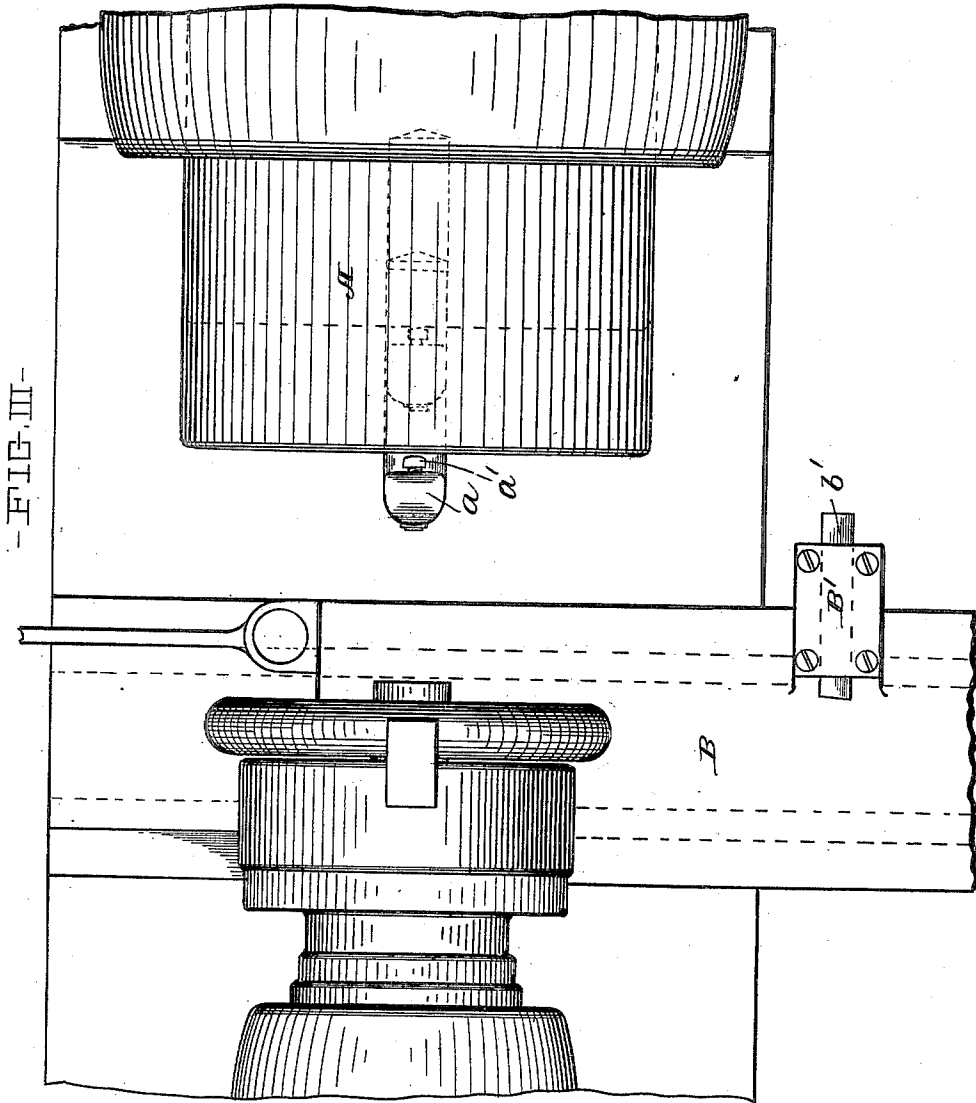

Witnesses
J. C. Turner
A. C. Merrill

Inventor,
J. P. Brophy
By *J. D. Fay*
Atty.

UNITED STATES PATENT OFFICE.

JOHN P. BROPHY, OF CLEVELAND, OHIO, ASSIGNOR TO THE CLEVELAND MACHINE SCREW COMPANY, OF SAME PLACE.

AUTOMATIC LATHE ATTACHMENT.

SPECIFICATION forming part of Letters Patent No. 649,902, dated May 22, 1900.

Application filed July 17, 1899. Serial No. 724,089. (No. model.)

To all whom it may concern:

Be it known that I, JOHN P. BROPHY, a citizen of the United States, and a resident of Cleveland, county of Cuyahoga, and State of Ohio, have invented a new and useful Improvement in Automatic Lathe Attachments, of which the following is a specification, the principle of the invention being herein explained and the best mode in which I have contemplated applying that principle so as to distinguish it from other inventions.

My invention relates to attachments for automatic lathes for performing special operations upon the work in connection with other operations to be performed upon the same work by the different tools in the revolving turret before removing said work from the head-stock of the lathe; and it consists of means for counterboring wheels and other objects upon which it is required to perform such counterboring operation.

The annexed drawings and the following description set forth in detail certain mechanism embodying the invention, such disclosed means constituting but one of various mechanical forms in which the principle of the invention may be used.

In said annexed drawings, Figure I represents a front elevation of a portion of an automatic lathe to which my invention has been attached, showing a cross-section of a wheel in the act of being counterbored secured to the clutch in the head-stock of the latter, the tool-holder being shown in longitudinal cross-section on the cross-slide, showing the tool and other portions in elevation therein, together with other portions of the lathe shown. Fig. II represents a side elevation of the parts shown in Fig. I, illustrating the relation of the parts during the operation of the tool upon the work; and Fig. III represents a top plan of same, showing in dotted lines a retracted position of the turret.

The turret A is intermittently rotated and advanced toward the work held and rotated by suitable rotating blank-gripping means C by suitable mechanism in use in machines of this character and has secured in one of the tool-holding devices an angle-piece *a*, provided with an adjustable screw *a'*. The axis of rotation of the turret is made parallel with

that of the axis of rotation of the blank-gripping means and lies in different planes parallel with the direction of reciprocation of the cross-slide. The cross-slide B is also advanced toward the work by means of suitable mechanism. Formed upon said cross-slide is a tool-holder B', having a longitudinal tool-seat *b*, in which slides the counterboring-tool *b'*. Said tool is provided with a pin *b²*, Fig. I, projecting downwardly through a slot *b³* and which engages a plunger *b⁴*, seated in a bore *b⁵*, drilled from the end of the tool-holder parallel with the tool-seat *b*. Intermediately of the inner end of the plunger and the inner end of the bore is a spring *b⁶*, which tends to move the tool toward the turret, the movement produced thereby being limited by means of a screw *b⁷*, projecting into a slot *b⁸*, formed in the lower portion of the plunger. Said slot *b⁸* is of a length such that the cutting edge of the tool is caused to normally be located intermediately of the plane of that face of the work adjacent to the turret and the turret, as shown in Fig. I. The tool is thus enabled to pass and take up a position opposite its point of entrance into the work for the boring operation, as shown in Fig. I. The mechanism is so timed and arranged that when the cross-slide has reached the end of its inward stroke such position brings the tool opposite its point of entrance into the work. Thereupon the turret advances, after having been revolved to bring the end of the adjusting-screw *a'* on the angle-piece into a position such that a line drawn through the center of said end and the center of the adjacent tool end will be parallel with the line of reciprocating travel of the turret. The tool is thus engaged by said screw and fed into the work, thus performing the counterboring operation, upon completion of which the turret returns and permits the spring to retract the tool. The slide is thereupon withdrawn, as shown in Fig. III, carrying the tool without the path of other tools on the turret which might be required to operate in the same location.

By making the engaging piece *a* of angular construction it is seen that the time of reciprocation of the cross-slide may be altered without the necessity of changing the time of

advance of the turret, and by changing the angular position of the angle-piece its proper engagement with the cutting-tool still be obtained. This construction hence permits of a wider range of adjustability of the attachment than would be obtained if the contact-piece were incapable of angular change and perfect engagement of the tool and angle-piece may always be had. The axes of the turret and gripping means being in different planes, as above described, such adjustment is made possible.

Other modes of applying the principle of my invention may be employed instead of the one explained, change being made as regards the mechanism herein disclosed, provided the means covered by either of the following claims be employed.

I therefore particularly point out and distinctly claim as my invention—

1. In an automatic lathe, the combination of rotatable blank-gripping means, a turret

having its axis of rotation parallel with the axis of rotation of said gripping means, and a cutting-tool, said turret provided with an angularly-adjustable contact-piece for engaging said tool whereby the latter may be advanced toward said gripping means, substantially as set forth.

2. In an automatic lathe, the combination of a rotatable turret, rotatable blank-gripping means, and a reciprocable cross-slide provided with a cutting-tool, the axes of rotation of the turret being parallel and located in different planes parallel with the direction of reciprocation of said slide, said turret provided with means for engaging said cutting-tool whereby the latter may be advanced toward said gripping means, substantially as set forth.

Signed by me this 5th day of July, 1899.

J. P. BROPHY.

Attest:

D. T. DAVIES,
A. E. MERKEL.