



(51) International Patent Classification:

B42D 25/24 (2014.01) B42D 25/36 (2014.01)

(21) International Application Number:

PCT/GB2020/050386

(22) International Filing Date:

19 February 2020 (19.02.2020)

(25) Filing Language:

English

(26) Publication Language:

English

(30) Priority Data:

PCT/GB2019/050574

	01 March 2019 (01.03.2019)	GB
1907706.4	30 May 2019 (30.05.2019)	GB
1908254.4	10 June 2019 (10.06.2019)	GB
1912422.1	29 August 2019 (29.08.2019)	GB

(71) Applicant: **DE LA RUE INTERNATIONAL LIMITED** [GB/GB]; De La Rue House, Jays Close, Basingstoke Hampshire RG22 4BS (GB).

(72) Inventors: **BOBAT, Shireen**; De La Rue International Limited, De La Rue House, Jays Close, Basingstoke Hampshire RG22 4BS (GB). **SUGDON, Matthew**; 14 Fullerton Way, Tadley Hampshire RG26 3YN (GB). **FRY, Alexan-**

dra; De La Rue International Limited, De La Rue House, Jays Close, Basingstoke Hampshire RG22 4BS (GB).

(74) Agent: **BOULT WADE TENNANT LLP**; Salisbury Square House, 8 Salisbury Square, London Greater London EC4Y 8AP (GB).

(81) Designated States (unless otherwise indicated, for every kind of national protection available): AE, AG, AL, AM, AO, AT, AU, AZ, BA, BB, BG, BH, BN, BR, BW, BY, BZ, CA, CH, CL, CN, CO, CR, CU, CZ, DE, DJ, DK, DM, DO, DZ, EC, EE, EG, ES, FI, GB, GD, GE, GH, GM, GT, HN, HR, HU, ID, IL, IN, IR, IS, JO, JP, KE, KG, KH, KN, KP, KR, KW, KZ, LA, LC, LK, LR, LS, LU, LY, MA, MD, ME, MG, MK, MN, MW, MX, MY, MZ, NA, NG, NI, NO, NZ, OM, PA, PE, PG, PH, PL, PT, QA, RO, RS, RU, RW, SA, SC, SD, SE, SG, SK, SL, ST, SV, SY, TH, TJ, TM, TN, TR, TT, TZ, UA, UG, US, UZ, VC, VN, WS, ZA, ZM, ZW.

(84) Designated States (unless otherwise indicated, for every kind of regional protection available): ARIPO (BW, GH, GM, KE, LR, LS, MW, MZ, NA, RW, SD, SL, ST, SZ, TZ, UG, ZM, ZW), Eurasian (AM, AZ, BY, KG, KZ, RU, TJ, TM), European (AL, AT, BE, BG, CH, CY, CZ, DE, DK, EE, ES, FI, FR, GB, GR, HR, HU, IE, IS, IT, LT, LU, LV, MC, MK, MT, NL, NO, PL, PT, RO, RS, SE, SI, SK, SM,

(54) Title: A SECURITY SHEET

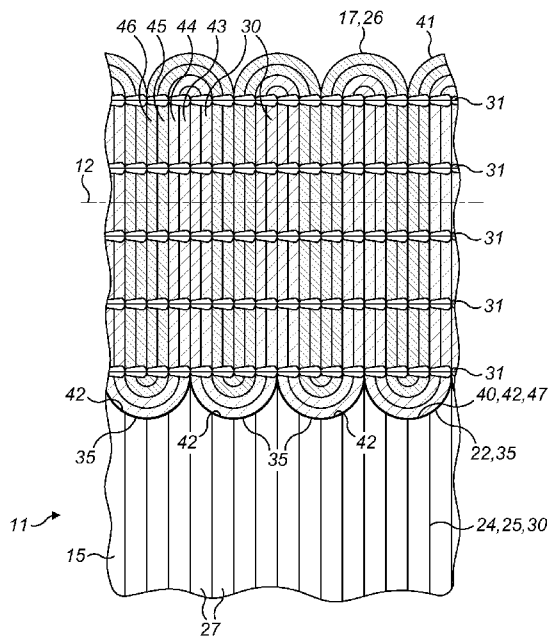

FIG. 4

(57) Abstract: The present disclosure is directed towards a security sheet (11) comprising a data sheet (15) and an attachment layer (17) for attaching the data sheet (15) in a security document (10). The data sheet (15) is attached to the attachment layer (17) at an inner edge (22) having a nonlinear inner edge (22) profile. The term "nonlinear" means that an edge profile is not straight and comprises at least one curve and/or at least two straight lines at a non-straight angle to one another. The present disclosure further provides a security document (10) comprising such a security sheet (11) and a method of manufacturing such a security sheet (11) or document (10).



TR), OAPI (BF, BJ, CF, CG, CI, CM, GA, GN, GQ, GW,
KM, ML, MR, NE, SN, TD, TG).

Published:

— *with international search report (Art. 21(3))*

A SECURITY SHEET

Technical Field

The present disclosure is directed towards a security sheet, a security document
comprising such a security sheet and a method of manufacturing such a security sheet or
5 document.

Background

Security documents and booklets, such as passports, passbooks, identification documents,
certificates, licences, cheque books and the like, commonly include a security sheet
10 comprising a data sheet. A passport booklet typically comprises a cover, a plurality of
internal visa pages and at least one data sheet displaying the personal data of the passport
holder. Typically the visa pages are made from paper and are sewn together along a stitch
line coincident with the fold of the document. The data sheet may be formed from a plastic,
typically polycarbonate, and during its manufacture a number of thin plastic layers are laid
15 over one another and laminated together, thereby forming a thicker plastic body. As this
plastic body is typically rigid it is not directly attached at the stitch line or otherwise the
booklet may not be able to bend effectively about the fold.

Instead, the security sheet may comprise a flexible hinge or attachment layer embedded in
20 and extending from the plastic body of the data sheet and the data sheet is attached about
the fold using the flexible hinge. Such arrangements are disclosed in EP-B1-1592565 and
EP-B1-1592565. However, fraudsters may attempt to manipulate the security document by
separating the data sheet and flexible hinge along the interface therebetween and
replacing the data sheet with one containing fraudulent personal data.

25

Summary

An object of the present disclosure includes increasing the difficulty of fraudulently
dismantling a security sheet by separating a data sheet from an attachment layer. A further
object of the present disclosure includes improving the identification by inspection officers
30 of any such dismantling in a fraudulent security document. Further objects include
providing an improved method of manufacture of such a security sheet and a security
document comprising such a security sheet.

The present disclosure therefore provides a security sheet, security document and method
35 in accordance the claims. In the present disclosure the term "nonlinear" means that an
edge profile is not straight and comprises at least one curve and/or at least two straight

lines at a non-straight angle to one another. By virtue of the inner edge profile being nonlinear a fraudster is unable to effectively separate the data sheet from the attachment layer by cutting along a straight line and parallel to an outer edge and/or fold line of the security sheet. In particular, when cutting a straight line and parallel to the outer edge and/or fold line, which is the most common and easiest method of separating the data sheet from the rest of the security sheet, they can only cut through both the attachment layer and data sheet, through only the data sheet or through only the attachment layer. As the inner edge is nonlinear, the removed data sheet will always be attached to part of the attachment layer and/or vice-versa. It is much harder for a fraudster to replace the data sheet with one containing fraudulent personal data because they will always have to replicate at least part of the data sheet and attachment layer. Due to the increased likelihood of poor replications, fraudulent alterations are therefore also easier to identify.

In the present disclosure the term “edge profile” refers to the shape or outline of an edge when an outer surface extending from the edge is viewed in plan view. Thus, for example, if a recess extends into part of the thickness of the inner edge of the data page (e.g. a hole through the centre of the thickness), the inner edge profile does not include the perimeter of the recess because the recess is not visible when an outer surface of the data sheet is viewed in plan view. However, if the inner edge includes a protrusion or recess extending across the entire thickness of the data sheet, the inner edge profile includes the protrusion or recess because they are visible in plan view. The inner edge profile may comprise at least one inner edge section. In the present disclosure the term “edge section” refers to a section or part of an edge profile and thus refers to the shape or outline of a part of an edge when an outer surface extending from the edge is viewed in plan view. The edge profile may comprise a single edge section defining the entirety of the edge profile or may be split into or defined by a plurality of edge sections adjacent to one another.

The data sheet preferably extends between the inner edge and an outer edge, which may be opposite the inner edge. The inner and outer edges may extend between parallel side edges (which may be substantially straight or linear) of the data sheet. The outer edge may comprise an outer edge profile comprising at least one outer edge section that is straight or linear. Preferably the outer edge profile is straight along at least 90% of its width. The inner edge profile and/or at least one inner edge section may extend nonparallel to the outer edge, outer edge profile and/or at least one outer edge section. The present disclosure therefore provides, alternatively or in addition to the inner edge profile being nonlinear, a security sheet comprising a data sheet and an attachment layer for attaching the data

sheet in a security document, wherein the data sheet extends between inner and outer edges and is attached to the attachment layer at the inner edge, the inner edge having an inner edge profile comprising at least one inner edge section extending nonparallel to the outer edge.

5

The attachment layer preferably comprises a fold line and the inner edge profile and/or at least one inner edge section preferably extends nonparallel to the fold line. The present disclosure also provides, in addition or alternatively to the inner edge profile being nonlinear and/or the inner edge being nonparallel to the outer edge, a security sheet comprising a data sheet and an attachment layer, wherein: the attachment layer comprises a fold line and is for attaching the data sheet in a security document; and the data sheet is attached to the attachment layer at an inner edge of the data sheet, the inner edge having an inner edge profile comprising at least one inner edge section extending nonparallel to the fold line. In the present disclosure the term "fold line" refers to a straight line of fold along which the attachment layer is designed or arranged to be folded. In particular, the attachment layer may comprise a fold (i.e. at the fold line) and/or may be folded about the fold line. The security document may comprise a stitch line for attaching the security sheet therein, such as to a cover and/or at least one leaf, although other attachment means such as adhesion may be used. The stitch line is preferably coincident with the fold line, but they may be instead be offset.

10
15
20

A data sheet height extending between the inner and outer edges preferably varies along a data sheet width. The data sheet width may be perpendicular to the data sheet height. In particular, by being nonlinear, the inner edge may not extend along a straight line between the two corners formed between the inner edge and the side edges. In the present disclosure "height" refers to a dimension perpendicular to the fold line and/or outer edge and "width" refers to a dimension parallel to the fold line and/or outer edge. In preferred embodiments the data sheet height may vary along the width by at least approximately 0.5 mm, at least approximately 1 mm, at least approximately 2 mm or at least approximately 3 mm; and/or less than or equal to approximately 10 mm, less than or equal to approximately 8 mm or less than or equal to approximately 5mm.

25
30

The attachment layer may comprise a hinge portion located outside of the data sheet and may comprise a connection portion extending from the hinge portion into and/or onto the data sheet. The hinge portion may be formed from the part of the attachment layer that extends from the inner edge outside of or beyond the data sheet and the connection

35

portion may be formed from the part of the attachment layer that is located in and/or over the data sheet. The connection portion may be at least partially embedded in the data sheet by extending at least partially into the thickness of the data sheet and/or may at least partially extend over at least one outer surface of the data sheet. The hinge and/or
5 connection portion preferably extend along at least approximately 75%, at least approximately 90% or all of width of the inner edge.

Preferably at least part of the hinge portion is thicker than the connection portion such that the hinge portion comprises a proximal edge from which the connection portion extends.
10 The proximal edge may thus be a ridge or ledge out of which the connection portion extends. The thickness of the thicker part or whole of the hinge portion may be substantially the same as or greater than, for example at least 100% or 110% of, the thickness of the data sheet. Thus the thicker part or whole of the hinge portion is preferably at least approximately 75% as thick or at least approximately 90% as thick as the data
15 sheet. Preferably the thicker part extends across at least approximately 50%, at least approximately 75%, at least approximately 90% or the whole of the hinge portion. Thus the proximal edge may extend across part or substantially all of the width of the hinge portion.

The hinge portion may comprise a distal edge located on the opposing side of the fold line to the proximal edge. The distal edge is preferably straight and nonparallel. A hinge portion
20 height extending between the proximal and distal edges may vary along a width of the hinge portion.

Preferably the proximal edge has a proximal edge profile which is preferably nonlinear. The
25 proximal edge profile may comprise at least one proximal edge section and the proximal edge profile and/or at least one proximal edge section may extend nonparallel to the fold line and/or the outer edge, outer edge profile and/or at least one outer edge section. The present disclosure also provides, in addition or alternatively to the inner edge profile being nonlinear and/or the inner edge being nonparallel to the outer edge and/or fold line, a
30 security sheet comprising a data sheet and an attachment layer attached to and extending from the data sheet for attaching the data sheet in a security document, wherein the attachment layer comprises: a connection portion located in and/or over the data sheet; and a hinge portion extending from the data sheet, wherein at least part of the hinge portion is thicker than the connection portion to form a proximal edge proximal an inner
35 edge of the data sheet and from which the connection portion extends, wherein the proximal edge comprises a nonlinear proximal edge profile.

The proximal edge is preferably proximal to, opposes and/or abuts the inner edge of the data sheet. The inner and proximal edge profiles may substantially match each other, be meshed with each other and/or abut along substantially all of their lengths. In particularly preferred embodiments, at least one proximal edge section of the proximal edge of the hinge portion, and preferably the entire proximal edge, is aligned with, is located adjacent to, is the inverse shape of, is meshed with and/or abuts at least one inner edge section of the inner edge, and preferably the entire inner edge, of the data sheet. Preferably, at least one proximal edge section extends inwardly into the hinge portion and at least one inner edge section extends outwardly from the data sheet into the at least one inwardly extending proximal edge section or vice-versa. However, the proximal and inner edges may not be aligned with one another along at least part of their lengths, such as by having different proximal and inner edge profiles, and/or may be separated from one another along at least part of their lengths.

15

The inner and/or proximal edge profiles may be periodic by comprising a plurality of repeating inner and/or proximal edge sections having the same shape, optionally in repeating sequences of inner and/or proximal edge sections with different shapes. Thus the inner and/or proximal edge profiles may be in the shape of a repeating waveform and may comprise a sinusoid, sawtooth wave, cycloid, a square wave, a triangular wave and the like. The inner and/or proximal edge profiles may be aperiodic by comprising a plurality of different inner and/or proximal edge sections and/or by having no substantially repeating sequences therein.

25

The plurality of inner and/or proximal edge sections may be the same as each other, such that the respective edge profile is periodic, or may be different from one another, preferably in an aperiodic manner such that the respective edge profile is aperiodic. Preferably inner and/or proximal edge profile comprises at least five, at least ten or at least fifteen sections. Preferably the width of at least one or each inner and/or proximal edge section is at least approximately 1 mm, at least approximately 2 mm or at least approximately 3 mm and/or is less than or equal to approximately 4 mm, less than or equal to approximately 6 mm or less than or equal to approximately 10 mm.

30

Preferably at least one inner and/or proximal edge section: extends inwardly into and/or outwardly from the data sheet and/or hinge portion; and/or comprises at least one straight, curved, convex or concave inner and/or proximal edge section. Preferably at least one

inner and/or proximal edge section comprises: at least one of a tooth, sinusoid, castellation (e.g. a rectangular or square tooth) and/or triangular tooth.

5 It is noted that the edge profiles and sections may not exactly confirm to such shapes due to manufacturing tolerances, so the present disclosure refers to the edge profiles and sections as comprising such shapes in terms of their appearance being generally according to such shapes. For example, if the hinge portion comprises a textile as discussed below, the proximal edge profile may not be a perfect shape (e.g. a perfect cycloid) initially and may also change slightly during manufacture as plastic, as discussed below, is pressed
10 against the proximal edge. Thus the references in the present disclosure to the edge profiles and sections forming certain shapes should be interpreted according to their overall appearance with tolerances around those shapes.

The data sheet is preferably rigid, preferably comprises a plastic and is preferably formed
15 from at least one plastic layer and preferably a plurality of plastic layers overlying one another and attached together. Preferably forming the data sheet comprises applying heat and/or pressure, such as by welding or lamination, to the at least one plastic layer and attachment layer such that they are attached together. In the case of the data sheet being formed from a plurality of plastic layers, they may be fused together during such
20 application. One or more plastic layers may be at least partially opaque, at least partially transparent and/or laser markable. The attachment layer may be attached between adjacent plastic layers and/or at an outer surface of at least one plastic layer such that the connection portion is at least partially embedded in the data sheet. Thus preferably forming the data sheet and attaching the attachment layer occurs simultaneously. The
25 plastic of the data sheet and plastic layers may comprise at least one of a thermoplastic polymer, polycarbonate, polybutylene terephthalate, polyester, polyethylene, polypropylene, polyvinyl chloride, a co-polymer comprised of any of the previous thermoplastic polymers and the like.

30 Preferably, the inner edge is formed into the inner edge profile being nonlinear, and/or nonparallel to the fold line and/or outer edge, during the application of heat and/or pressure to the at least one plastic layer and attachment layer. Thus the inner edge may be linear, and/or parallel to the outer edge and/or fold line, prior to the application of heat and/or pressure. The proximal edge may have substantially the same proximal edge profile before
35 and after the application of heat and/or pressure. Such a manufacturing step results in the inner and proximal edges abutting in a particularly tight fit such that removing the data

sheet along the interface between them is more difficult. During the application of heat and/or pressure the at least one plastic layer may be substantially softened and the inner edge may be moulded or pushed into conformity with the proximal edge. In particular, the inner edge may migrate into at least one inwardly extending proximal edge section to form at least one outwardly extending inner edge section or vice-versa. Thus prior to such application only part of the inner edge may abut the proximal edge and after such application substantially all of the inner edge abuts the proximal edge. Alternatively, the inner edge may be pre-formed or pre-cut into the nonlinear inner edge profile prior to attachment to the attachment layer.

10

Preferably the at least one plastic layer does not migrate over the hinge portion, for example by the hinge portion being at least the thickness of the at least one plastic layer prior to application of heat and/or pressure. However, in some embodiments the at least one plastic layer, or one or more of the plastic layers, may migrate over part of the proximal edge and/or hinge portion, such as if part of the proximal edge and/or hinge portion are thinner than the at least one plastic layer prior to lamination. For example, the proximal edge may vary in thickness and/or may only extend along part of the hinge portion, such that the plastic can flow around it.

15

20

Preferably the hinge portion and/or attachment layer comprises a textile, which is preferably woven or knitted and comprises at least one yarn. A textile is preferable because if a fraudster cuts through the hinge portion the textile will unravel and therefore is very difficult to reassemble. Furthermore, using a textile assists in ensuring a tight fit between the inner and proximal edges such that a fraudster is effectively forced to attempt to cut a straight line rather than cut along and between the inner and proximal edges. The textile may be formed from the at least one yarn by weaving, knitting, sewing or another interlacing method. In the present disclosure "knitting" refers to forming closed, interlocked loops between yarns. Preferably the knitting is crochet knitting and each interlock comprises a crochet knitting stitch. In the present disclosure "yarns" are long, thin strand of materials forming part of the textile. For example, the at least one yarn may comprise a material, such as a plant, mineral, animal or synthetic material, selected from at least one of cotton, wool, linen/flax, bamboo, silk, jute, modal, polyamide, polyester, viscose, glass, polypropylene, polyaramid, polyurethane, nylon, bonded nylon, rayon, acrylic, polycotton and/or other suitable fibres. The at least one yarn may be substantially circular, trilobal, fibrillated, grooved, dog bone or multiform in cross section. A ply structure of the at least one yarn may be single or one-ply (i.e. single strands of fibres twisted together or single

25

30

35

filament strands), multi-ply (i.e. a plurality of single yarns twisted together) or cord yarns (i.e. a plurality of multi-ply yarns twisted together in a twist direction).

5 The textile of at least the hinge portion and/or of the attachment layer preferably comprises a plurality of interlaced, knitted, woven, stitched, overlapping or otherwise integrated wefts and warps formed from the at least one yarn. During manufacture, a plurality of warp yarns may be fed by a machine into contact with the weft yarns for interlacing therewith.

Preferably the machine is a knitting machine and more preferably a crochet knitting machine. The warps may extend substantially parallel to one another and/or the fold line.

10 The wefts may extend substantially parallel to one another and/or may be substantially perpendicular to the warps and/or fold line. The connection portion may comprise at least portions of the wefts, referred to as connection wefts, extending out of the hinge portion. The connection portion may instead comprise a mesh of both wefts and warps, rather than only the connection wefts, such that the entire attachment layer is a meshed textile.

15 Although the connection wefts are preferably part of the textile, they may instead comprise strips, a film and/or other elongate bodies extending from the hinge portion.

The hinge portion preferably comprises a textile having at least one infill yarn forming the at least one proximal edge section and/or proximal edge. In particular, the at least one infill
20 yarn may comprise at least one infill yarn section at the proximal edge forming the at least one proximal edge section. The at least one infill yarn may extend nonlinearly and the at least one infill yarn section may have any of the shapes discussed above in respect of the at least one proximal edge section. The or each infill yarn may extend continuously through
25 the hinge portion to form a plurality of wefts of the hinge portion and may be interlaced with at least two parallel warps. Each warp may comprise a plurality of loops, wherein at least one, preferably at least two, wefts extend through and are interlocked in each loop. The hinge portion may be thicker than the connection portion by virtue of the at least one infill yarn being thicker than the connection wefts and/or by having a higher density or thread count of warps and/or wefts.

30 Preferably the same at least one infill yarn may form a plurality or all of the proximal edge sections. Preferably the at least one infill yarn extends substantially along a periodic waveform, such a sinusoid, and at least one peak or trough of the periodic waveform (e.g. the curve of a sinusoid) is located at the proximal edge to form the at least one yarn
35 section. The at least one infill yarn preferably extends along the periodic waveform between the proximal and distal edges. In the case of a plurality of infill yarns, the infill

yarns may extend parallel and adjacent to one another along the periodic waveform. Preferably the at least one infill yarn comprises at least one curved yarn section at the proximal edge and at least one opposing curve may be located at the distal edge such that it follows a sinusoidal periodic waveform. Alternatively, different infill yarns may form adjacent or different proximal edge sections and the textile of the header may comprise any other suitable arrangement in which at least one infill yarn forms the at least one proximal edge section.

In a particularly preferred embodiment the data sheet comprises a plastic and the hinge portion comprises a textile having at least one infill yarn forming at least one proximal edge section. During the application of heat and/or pressure the plastic of the at least one plastic layer forming the data sheet is pushed into spaces defined at the proximal edge by the at least one infill yarn.

The security document of the present disclosure may be a security booklet, such as a passport, passbook, identification document, certificate, licence, cheque book or the like. The data sheet preferably comprises personal data relating to a holder of the security sheet or security document. The personal data may comprise a name, date of birth, portrait and/or machine readable data and may be printed and/or laser marked on the data sheet.

20

Brief Description of the Drawings

By way of example only, embodiments of a security sheet, a security document and a method in accordance with the present disclosure are now described with reference to, and as shown in, the accompanying drawings, in which:

FIGURE 1 is a perspective view of a security document, particularly a passport, according to the present disclosure in an open configuration;

FIGURE 2 is a schematic cross-sectional side elevation of a fold area of the security document of Figure 1 in an exploded configuration;

FIGURE 3 is a schematic plan view of a security sheet of the security document of Figure 1 with personal data hidden from view;

FIGURE 4 is a detailed schematic plan view of the security sheet of Figure 3;

FIGURE 5 is a detailed schematic plan view showing an outer plaster layer of a plurality of plastic layers and an attachment layer prior to lamination for forming the security sheet of FIGURE 3; and

FIGURE 6 is a first embodiment of a cross-sectional view through section A-A of Figure 5;

FIGURE 7 is a cross-sectional view of the security sheet of Figure 3 formed by the attachment of the layers of Figures 5 and 6;

FIGURE 8 is a second embodiment of a cross-sectional view through section A-A of Figure 5; and

5 FIGURE 9 is a cross-sectional view of the security sheet of Figure 3 formed by the attachment of the layers of Figures 5 and 8.

Detailed Description

10 Figures 1 and 2 illustrate a security document 10, in this case a passport, in accordance with the present disclosure. The security document 10 comprises a security sheet 11, illustrated in further detail in Figures 3 to 7, foldable about and attached along a fold line 12 by stitching to a plurality of leaves 13. The plurality of leaves 13 may comprise a fibrous substrate, for example paper and/or cotton and may form visa pages. The security document 10 also comprises a cover 14, which is foldable about and attached to the fold
15 line 12 and/or is adhered to an outer leaf (not shown) located on the outside of the leaves 13 and security sheet 11.

The security sheet 11 comprises a data sheet 15 formed from a plurality of plastic layers 21 laminated together into a rigid plastic substrate comprising personal data 16 and an
20 attachment layer 17 attached to the data sheet 15. The data sheet 15 extends across a width from an inner edge 22, located proximate the fold line 12, to an outer edge 23, distal to the fold line 12. The inner and outer edges 22, 23 extend between parallel side edges 18, 19 of the data sheet 15. The data sheet 15 extends across a thickness between substantially planar first and second outer surfaces 28, 29. The inner edge 22 has a
25 nonlinear inner edge 22 profile or outline split into a plurality of (in this case over ten) substantially identically shaped inner edge sections 35 extending, in this example, nonparallel to the fold line 12 and outer edge 23. Each inner edge section 35 is curved and concave and extends inwardly into the data sheet 15. The concave inner edge sections 35 are connected to one another at their ends such that the inner edge 22 profile substantially
30 comprises a periodic cycloid. The inner edge sections 35 may instead be defined as the teeth defined between the curves. As a result, the data sheet 15 height, being the distance between the inner and outer edges 22, 23, varies along the width of the data sheet 15.

The attachment layer 17 is configured to securely connect the attachment layer 17 to the
35 data sheet 15 and to the rest of the security document 10. The attachment layer 17 is thus preferably flexible, substantially resistant to plastic deformation and tear resistant and may

comprise a substantially elongate sheet or body as illustrated. The attachment layer 17 comprises a connection portion 24 extending from a hinge portion 26. The connection portion 24 is located in or on and attached to the data sheet 15 and extends at least partially into the data sheet 15 (i.e. from the inner edge 22 towards the outer edge 23). The hinge portion 26 is located outside of the data sheet 15 and comprises the entire part of the attachment layer 17 located outside of the data sheet 15. The hinge portion 26 comprises the fold line 12 and thus the fold of the attachment layer 17.

The hinge portion 26 extends between a proximal edge 40 abutting and adjacent to the inner edge 22 of the data sheet 15 and a distal edge 41 on the opposing side of the fold line 12 to the proximal edge 40. In the illustrated embodiment the proximal edge 40 extends across the whole width of the attachment layer 17 by virtue of the entire hinge portion 26 being thicker than the connection portion 24. However, only part of the hinge portion 26 (e.g. only a central portion) may be thicker than the connection portion 24 such that the proximal edge 40 only extends across part of the width of the attachment layer 17 and hinge portion 26. As best illustrated in Figures 6 to 9, the connection portion 24 extends from the proximal edge 40, particularly from the within of the thickness of the hinge portion 26 such that the proximal edge 40 extends on either side of the connection portion 24. Alternatively, the connection portion 24 may extend from the top or bottom of the thickness of the hinge portion 26 such that the proximal edge 40 extends on only one side of the connection portion 24.

The proximal edge 40 has a nonlinear proximal edge 40 profile or outline comprising a plurality of (in this case over ten) proximal edge sections 42 extending, in this example, nonparallel to the fold line 12 and outer edge 23. As illustrated, each proximal edge section 42 may be curved and convex and may extend inwardly into the hinge portion 26. The convex proximal edge sections 42 are connected to one another at their ends such that the proximal edge 40 profile substantially comprises a periodic cycloid. The inwardly extending proximal edge sections 42 may also be defined as inwardly extending proximal edge sections 41 at the recessed or convex parts of the proximal edge 40 profile (i.e. between the convex proximal edge sections 42). As a result, the proximal edge 40 profile is nonlinear and the hinge portion 26 height, being the distance between the proximal and distal edges 40, 41, varies along the width of the attachment layer 17. The proximal edge sections 42 of the entire proximal edge 40 are meshed with and abut the inner edge sections 35 of the entire inner edge 22. Thus the cycloid of the proximal edge 40 profile is the inverse of that of the inner edge 22 profile.

A fraudster cannot cleanly separate the data sheet 15 from the hinge portion 26, such as if they are attempting to replace the data sheet 15 with one containing fraudulent personal data 16 and particularly if they are attempting to perform a straight cut parallel to the fold line 12. Referring to Figure 4, if a fraudster attempts to cut along a straight line parallel to the fold line 12 and extending between the peaks and troughs of the curved inner and proximal edge sections 35, 42, part of the hinge portion 26 will remain with the removed data sheet 15 and part of the data sheet 15 will remain with the attachment layer 17.

Similar unwanted remaining parts of the data sheet 15 or hinge portion 26 will also result if the fraudster attempts to cut along a straight line above or below the inner and proximal edges 22, 40 through the hinge portion 26 or the data sheet 15. In each case, the remaining parts of the hinge portion 26 or data sheet 15 would cause substantial difficulties for the fraudster attempting to replace the data sheet 15 and are also likely to result in discontinuities or the like that can be identified by a document inspector.

However, the difficulty of separating the data sheet 15 from the hinge portion 26 is also increased by the embodiment shown in Figures 1 to 9 in which the attachment layer 17 comprises a textile. By having a textile hinge portion 26 the proximal edge 40 can be formed tightly against the inner edge 22, thereby increasing the difficulty of cutting along the inner and proximal edges 22, 40. The attachment layer 17 and the hinge portion 26 comprise a textile, which may have a mesh of interlaced wefts 30 and warps 31 in at least the hinge portion 26. The connection portion 24 comprises portions of wefts 30, referred to as connection wefts 25, as illustrated in Figures 3 to 5, at least partially embedded in the data sheet 15. The plurality of connection wefts 25 are separated from an adjacent connection weft 25 by a spacing 27. The connection wefts 25 comprise portions of the wefts 30 extending out of and forming the hinge portion 26 as in Figures 3 to 5 (although visible in the Figures, the connection wefts 25 may or may not be visible at the first and/or second outer surface 28, 29 depending upon the opacity of the data sheet 15). The connection portion 24 is therefore firmly connected to the data sheet 15 by a frictional force applying a resistance to any attempted removal of the attachment layer 17 from the data sheet 15.

The hinge portion 26 comprises a plurality of, in this case four, infill yarns 43, 44, 45, 46, forming the proximal edge 40. An infill yarn 43 comprises a plurality of convex infill yarn sections 47 forming the plurality of convex proximal edge sections 42. The infill yarns 43, 44, 45, 46 extend adjacent to one another substantially along a periodic sinusoid as

illustrated. The infill yarns 43, 44, 45, 46 each extend continuously and form a plurality of wefts 30 of the hinge portion 26. The hinge portion 26 comprises a plurality of, in this case five, warps 31 and the warps 31 may be interlaced with the wefts 30 by knitting as illustrated. Each warp 31 comprises a plurality of loops and two wefts 30 extend through and are interlocked in each loop. The connection wefts 25 extend between and/or over the infill yarns 43, 44, 45, 46 and are also interlocked in the loops of the warps 31. Each connection weft 25 is substantially thinner than the infill yarns 43, 44, 45, 46 such that the hinge portion 26 is thicker than the connection portion 24.

10 The security sheet 11 may be formed by the connection together of the attachment layer 17 and at least one plastic layer 21 forming the data sheet 15 by, for example, by the application of heat and/or pressure, such as during lamination and/or welding, by adhesion and/or any other suitable method. Figures 5, 6 and 8 illustrate a plurality of plastic layers 21 (in Figure 5 only an outer plastic layer 21 is shown) and attachment layer 17 prior to attachment. During lamination or welding heat and/or pressure are applied to fuse or push the plurality of plastic layers 21 together and the plastic of at least one plastic layer 21 is pushed through the at least one spacing 27 between the connection wefts 25, through mesh openings of the mesh or through the textile (depending upon the construction of the connection portion 24). As illustrated in Figures 6 and 7, the attachment layer 17 may be located on the first and/or second outer surface 28, 29 formed by the outer plastic layers 21 prior to attachment. At least one strip 50 may overlap at least part of the connection portion 24 (Figure 6). During attachment, the connection portion 24 and, if present, at least one strip 50 are pressed into the first and/or second outer surface 28, 29 such that they are at least partially attached at, embedded in, adjacent to and/or overlapping the first outer surface 28 of the data sheet 15 (Figure 7). In particular, the connection portion 24 and, if present, at least one strip 50 are attached to or at least partially embedded within the data sheet 15 such that they forms part of the first outer surface 28 of the data sheet 15. Alternatively, as illustrated in Figures 8 and 9, the connection portion 24 may be attached between adjacent plastic layers 21 prior to the attachment (Figure 8) such that it is located within the thickness of the data sheet 15 after the attachment (Figure 9). The lamination may be performed using any suitable method and may be a substantially in-line method, similar to that of WO-A-2017/060684 and WO-A-2017/060688, in which a plurality of security sheets 11 are formed continuously.

35 The inner edge 22 is linear and parallel to the fold line 12 and outer edge 23 prior to the application of heat and/or pressure, such as by lamination or welding, and instead is

formed into the inner edge 22 profile being nonlinear and nonparallel to the fold line 12 and outer edge 23 during such application. As illustrated in Figures 5, 6 and 8, the inner edge 22 formed by the plurality of plastic layers 21 prior to application is straight and thus does not mesh with the proximal edge 40 or extend into the inwardly extending proximal edge sections 42. Only part of the inner edge 22 abuts the proximal edge 40, if at all. However, under the application of heat and/or pressure, the plurality of plastic layers 21 are softened and pushed into (see arrows 51 in Figures 5, 7 and 9) the inwardly extending proximal edge sections 42 such that the inner edge 22 changes shape and is meshed with the proximal edge 40 formed by the at least one infill yarn 43. Thus the inner and proximal edges 22, 40 form an abutting interface as illustrated in Figures 4, 7 and 9. Due to the hinge portion 26 being formed from a textile, which may be flexible, it will be appreciated that during manufacture the proximal edge 40 profile may change slightly as the yarns of the textile are moved by the plastic of the plastic layers 21 pressing against them. However, the overall shape of the proximal edge 40 remains substantially or broadly a cycloid.

In the illustrated embodiment the hinge portion 26 is substantially the same thickness as the data sheet 15 such that the softened plastic does not extend over the hinge portion 26. Furthermore, all of the plastic layers 21 have extended by the same amount towards the hinge portion 26 during the application of heat and/or pressure. However, plastic layers 21 may extend by different amounts into the hinge portion 26, such as if the proximal edge 40 is nonparallel to the thickness of the hinge portion 26 (i.e. such that the hinge portion 26 height varies through the hinge portion 26 thickness and/or the proximal edge 40 varies in thickness).

Various alternatives to the embodiments discussed above fall within the scope of the present disclosure. In particular, the inner edge 22 may be formed nonlinear and/or nonparallel to the fold line 12 and/or outer edge 23 prior to the application of heat and/or pressure. For example, the plurality of plastic layers 21 may be cut with the inner edge 22 formed nonlinear such that the softened plastic does not substantially migrate during lamination and/or welding. Alternatively, rather than pressing against the hinge portion 26, edges or buffers may be applied to the lamination plates to halt the flow of the plastic. Such a manufacturing method is particularly suitable if the proximal edge 40 is separated from the inner edge 22. Furthermore, the hinge portion 26 may comprise any other textile structure, or may comprise a non-textile structure such as one or more plastic layers, comprising the proximal edge 40.

CLAIMS:

1. A security sheet comprising a data sheet and an attachment layer for attaching the data sheet in a security document, wherein the data sheet is attached to the attachment layer at an inner edge having a nonlinear inner edge profile.
2. A security sheet as claimed in claim 1 wherein the inner edge profile comprises at least one inner edge section.
3. A security sheet as claimed in claim 2 wherein the inner edge profile is periodic and comprises a plurality of repeating inner edge sections or is aperiodic and comprises at least two inner edge sections having different shapes.
4. A security sheet as claimed in claim 2 or claim 3 wherein at least one inner edge section:
extends inwardly into and/or outwardly from the data sheet;
comprises at least one straight, curved, convex or concave inner edge section;
and/or
comprises at least one of a tooth, sinusoid, castellation, triangular tooth.
5. A security sheet as claimed in any one of the preceding claims wherein the data sheet comprises an outer edge opposite the inner edge, wherein:
the inner edge profile extends nonparallel to the outer edge; and/or
the data sheet comprises a data sheet height extending between the inner and outer edges that varies along a data sheet width, the data sheet width being perpendicular to the data sheet height.
6. A security sheet as claimed in any one of the preceding claims wherein the attachment layer comprises a hinge portion located outside of the data sheet and a connection portion extending from the hinge portion into and/or onto the data sheet.
7. A security sheet as claimed in claim 6 wherein at least part of the hinge portion is thicker than the connection portion such that the hinge portion comprises a proximal edge from which the connection portion extends.
8. A security sheet as claimed in claim 7 wherein the proximal edge has a nonlinear proximal edge profile comprising at least one proximal edge section.

9. A security sheet as claimed in claim 8 wherein at least one proximal edge section of the proximal edge of the hinge portion is aligned with, is located adjacent to and/or abuts at least one inner edge section of the inner edge of the data sheet.

5

10. A security sheet as claimed in claim 8 or claim 9 wherein the proximal edge profile is periodic and comprises a plurality of repeating proximal edge sections or is aperiodic and comprises at least two proximal edge sections having different shapes.

10

11. A security sheet as claimed in any one of claims 8 to 10 wherein at least one proximal edge section:

extends inwardly into and/or outwardly from the hinge portion;

comprises at least one straight, curved, convex or concave proximal edge section;

and/or

15

comprises at least one of a tooth, sinusoid, castellation, triangular tooth.

20

12. A security sheet as claimed in any one of claims 8 to 11 wherein at least one proximal edge section extends inwardly into the hinge portion and at least one inner edge section extends outwardly from the data sheet into the at least one inwardly extending proximal edge section.

25

13. A security sheet as claimed in any one of claims 6 to 12 wherein the attachment layer comprises a textile, the hinge portion comprising interlaced warps and wefts and/or the connection portion comprises connection wefts extending from the hinge portion.

30

14. A security sheet as claimed in any one of claims 8 to 13 wherein the hinge portion comprises at least one infill yarn forming the at least one proximal edge section and/or proximal edge.

15. A security sheet as claimed in claim 14 wherein the at least one infill yarn extends substantially along a periodic waveform and trough or peak of the periodic waveform is located at the proximal edge to form the at least one yarn section.

35

16. A security document comprising the security sheet of any one of the preceding claims and being foldable about a fold line, wherein the nonlinear edge profile extends nonparallel to the fold line.

17. A method of manufacturing a security sheet comprising a data sheet and an attachment layer for attaching the data sheet in a security document, the method comprising:

- providing the attachment layer;
- 5 forming the data sheet having an inner edge from at least one plastic layer; and
- attaching the attachment layer to the data sheet at the inner edge, the inner edge having a nonlinear inner edge profile.

18. A method as claimed in claim 17 comprising:

- 10 attaching the attachment layer to the data sheet by applying heat and/or pressure to the attachment layer and/or data sheet; and
- forming the inner edge into the nonlinear inner edge profile during the application of heat and/or pressure.

- 15 19. A method as claimed in claim 17 or claim 18 comprising applying heat and/or pressure such that the at least one plastic layer is softened and the inner edge is moulded or pushed into conformity with a nonlinear proximal edge of a hinge portion of the attachment layer.

- 20 20. A method as claimed in claim 19 wherein during the application of heat and/or pressure the inner edge migrates into at least one inwardly extending proximal edge section of the proximal edge to form at least one outwardly extending inner edge section of the inner edge or vice-versa.

- 25 21. A method as claimed in any one of claims 17 to 20 wherein attaching the attachment layer to the data sheet comprises attaching the attachment layer:

- between a plurality of the plastic layers; and/or
- at least partially embedding the attachment layer in and/or locating the attachment layer at an outer surface of the at least one plastic layer.

- 30 22. A security sheet comprising a data sheet and an attachment layer attached to and extending from the data sheet for attaching the data sheet in a security document, wherein the attachment layer comprises:

- a connection portion located in and/or over the data sheet; and
- a hinge portion extending from the data sheet, wherein at least part of the hinge
- 35 portion is thicker than the connection portion to form a proximal edge proximal an inner

edge of the data sheet and from which the connection portion extends, wherein the proximal edge comprises a nonlinear proximal edge profile.

23. A security sheet as claimed in claim 22 wherein the proximal edge profile comprises at
5 least one proximal edge section aligned with, located adjacent to and/or abutting at least one inner edge section of an inner edge of the data sheet.

24. A security sheet as claimed in claim 22 or claim 23 wherein the proximal edge profile is
10 periodic and comprises a plurality of repeating proximal edge sections or is aperiodic and comprises at least two proximal edge sections having different shapes.

25. A security sheet as claimed in any one of claims 22 to 24 wherein at least one proximal edge section of the proximal edge profile:

15 extends inwardly into and/or outwardly from the hinge portion;
comprises at least one straight, curved, convex or concave proximal edge section;
and/or
comprises at least one of a tooth, sinusoid, castellation, triangular tooth.

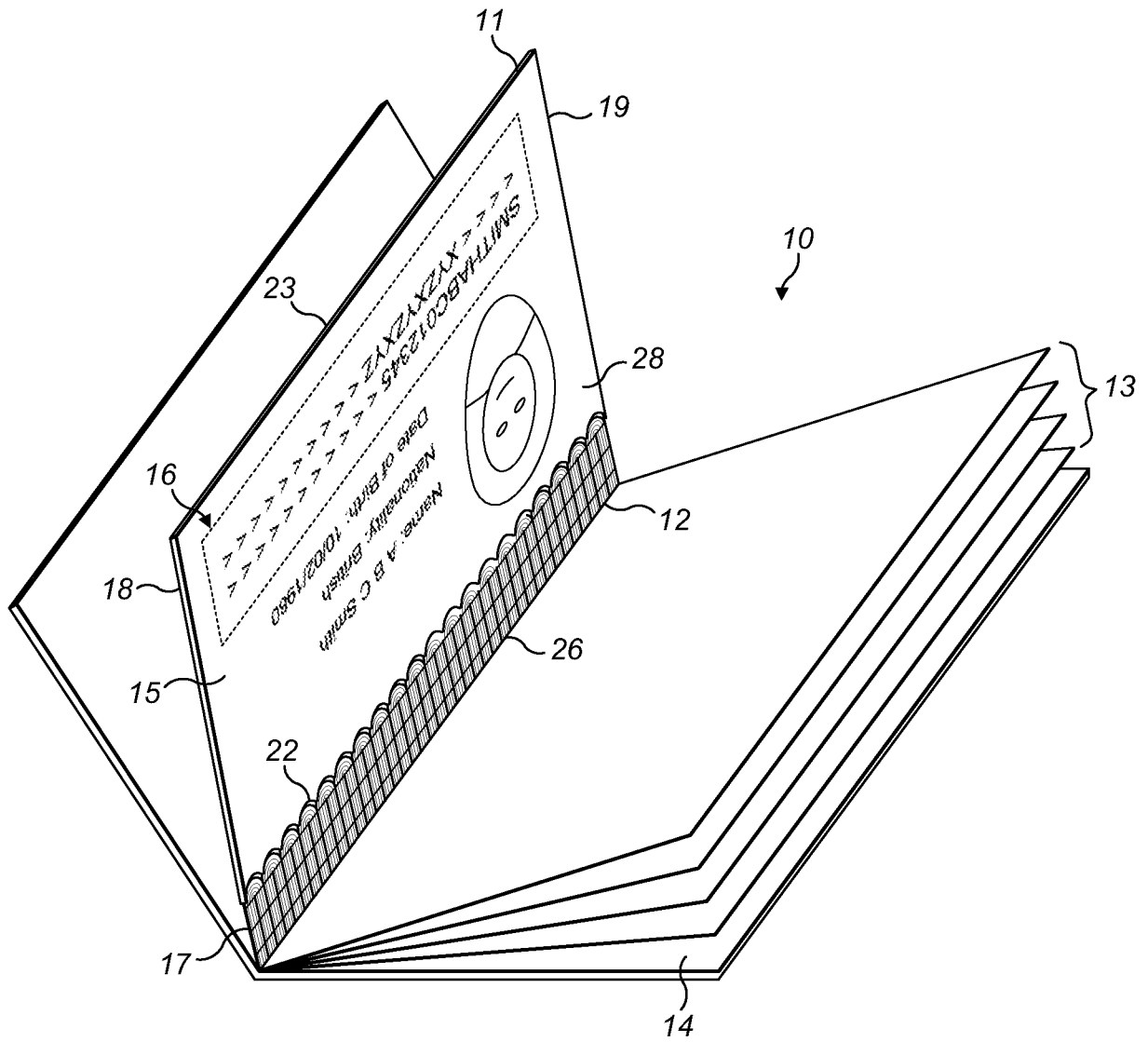

FIG. 1

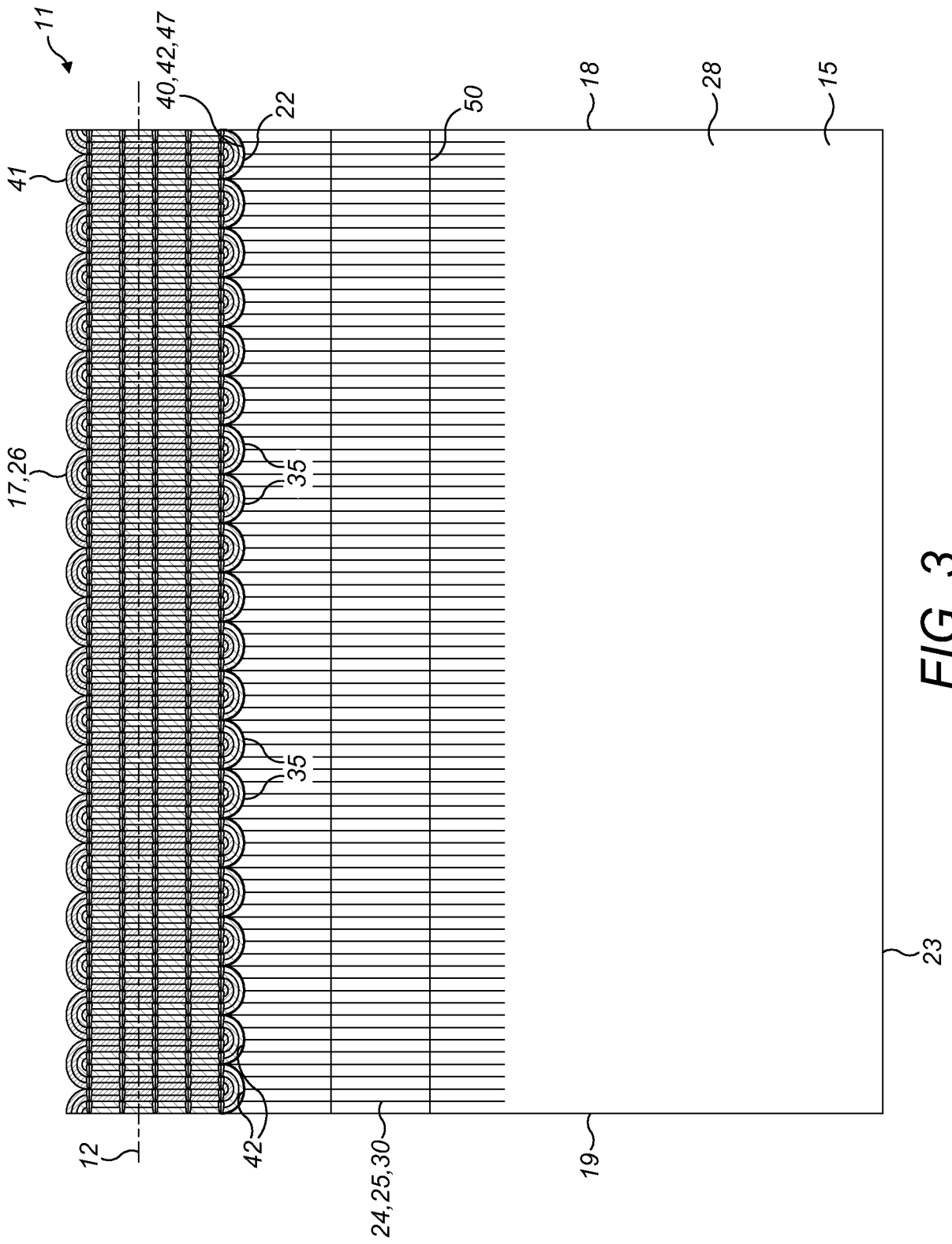

FIG. 3

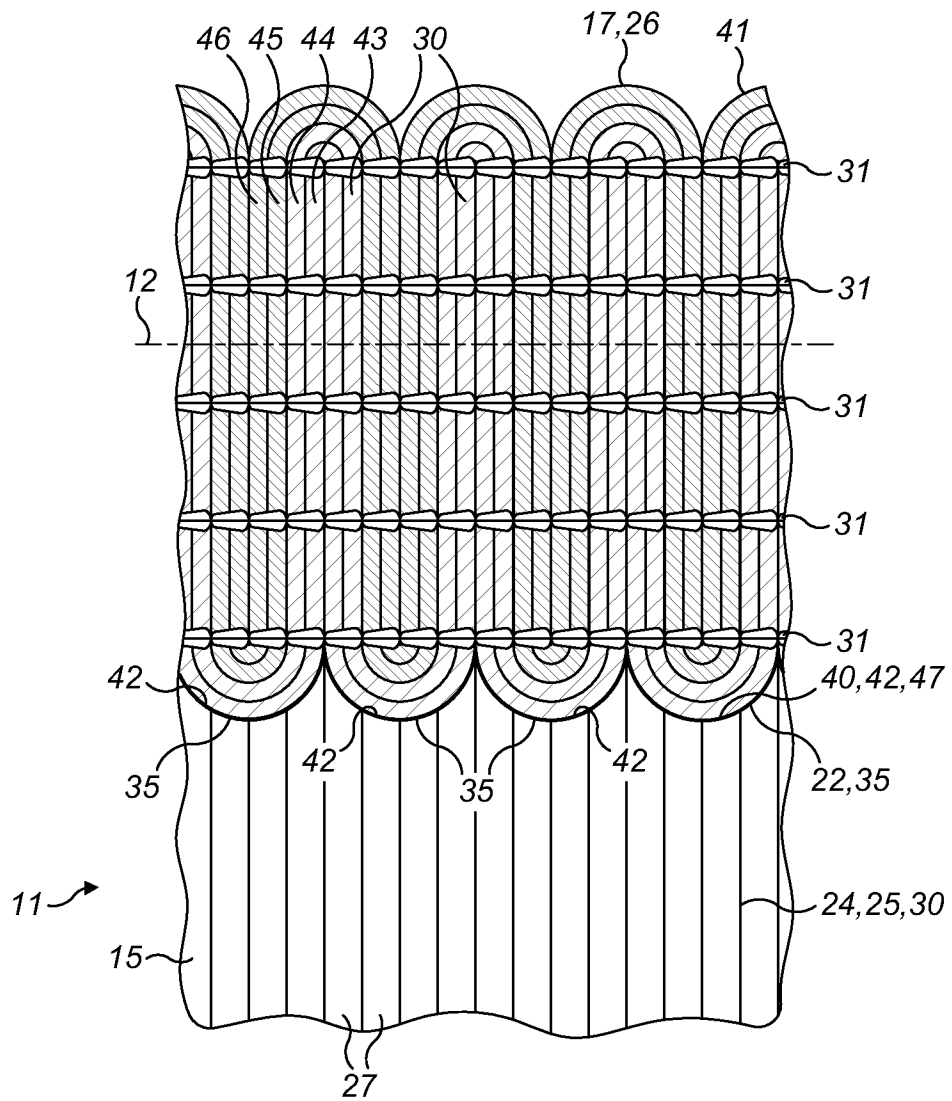

FIG. 4

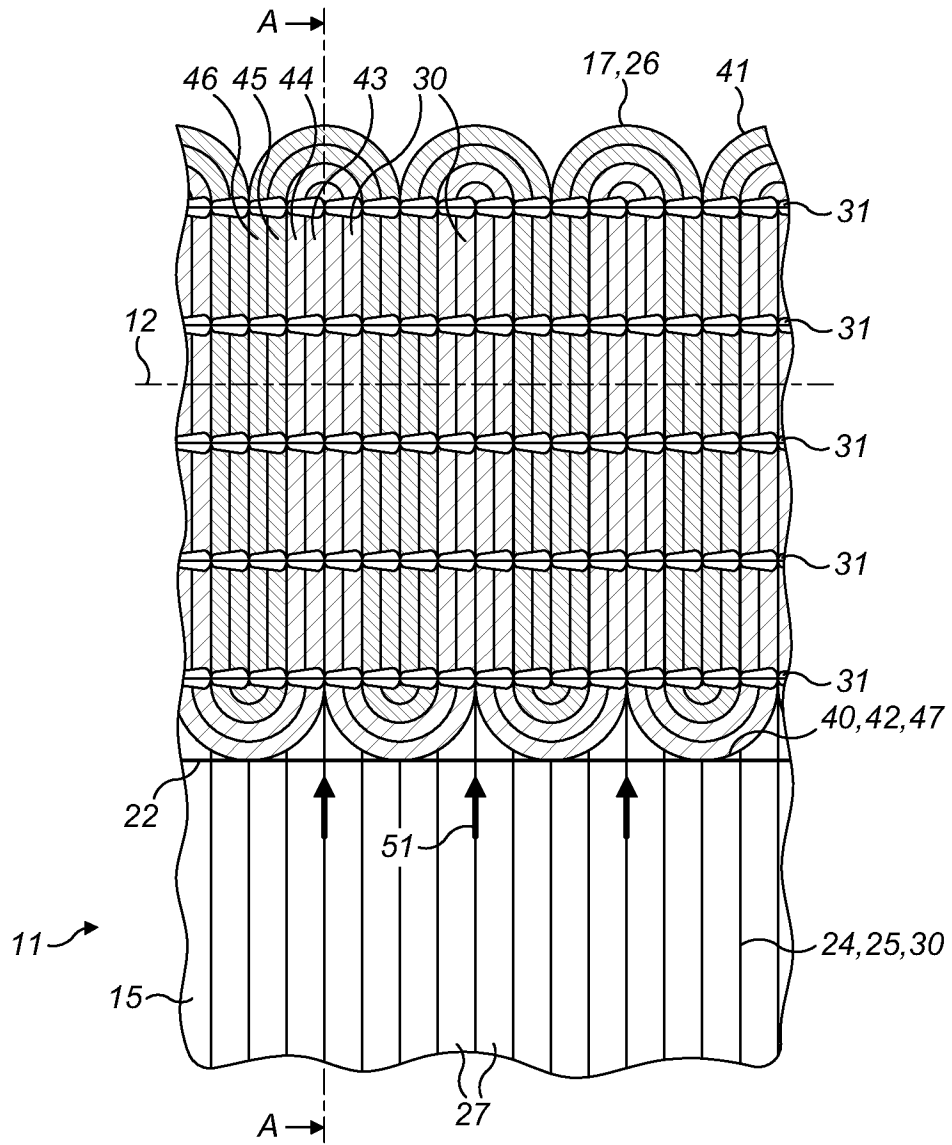

FIG. 5

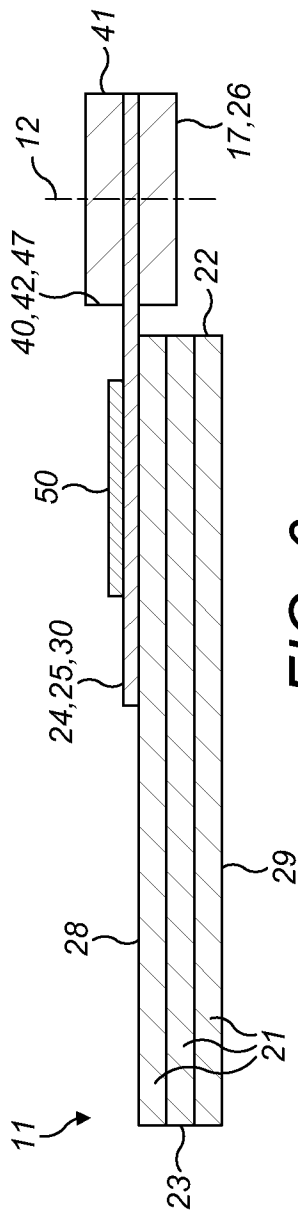

FIG. 6

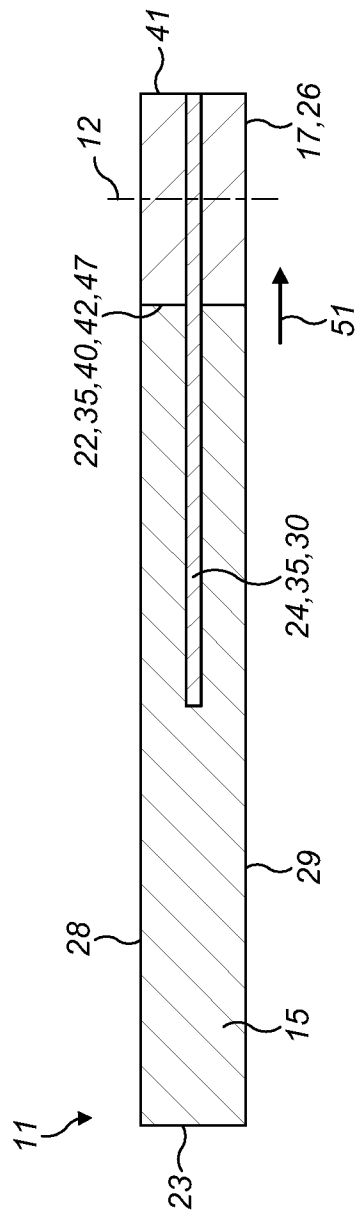

FIG. 7

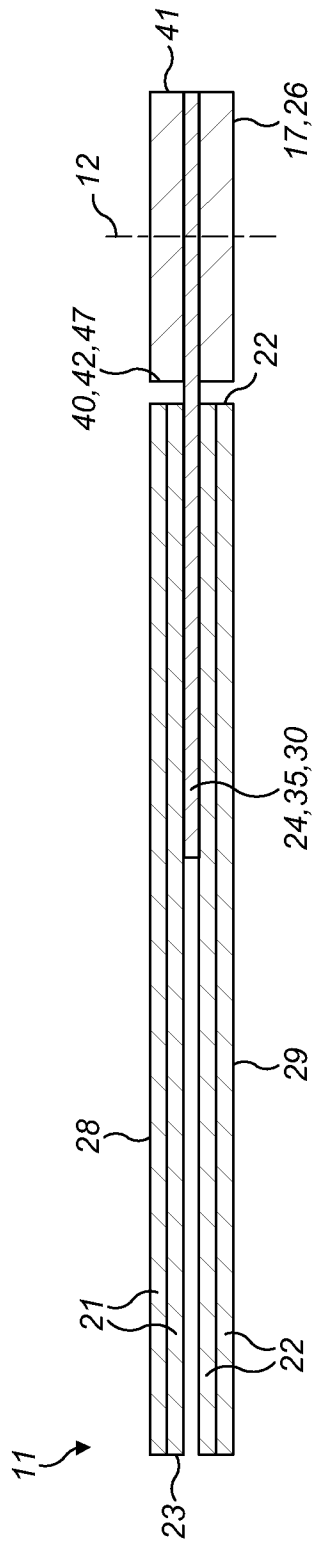

FIG. 8

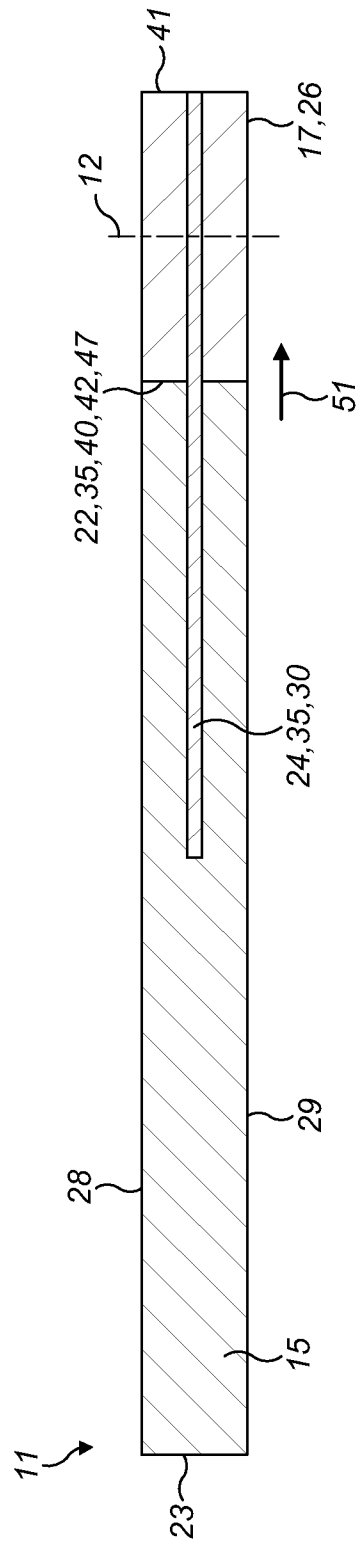

FIG. 9

INTERNATIONAL SEARCH REPORT

International application No
PCT/GB2020/050386

A. CLASSIFICATION OF SUBJECT MATTER
 INV. B42D25/24 B42D25/36
 ADD.
 According to International Patent Classification (IPC) or to both national classification and IPC

B. FIELDS SEARCHED
 Minimum documentation searched (classification system followed by classification symbols)
 B42D
 Documentation searched other than minimum documentation to the extent that such documents are included in the fields searched

Electronic data base consulted during the international search (name of data base and, where practicable, search terms used)
 EPO-Internal

C. DOCUMENTS CONSIDERED TO BE RELEVANT

Category*	Citation of document, with indication, where appropriate, of the relevant passages	Relevant to claim No.
X	DE 10 2010 054480 A1 (MUEHLBAUER AG [DE]) 14 June 2012 (2012-06-14) paragraphs [0012], [0013] paragraphs [0027], [0032], [0033]; figures -----	1-25

Further documents are listed in the continuation of Box C.

See patent family annex.

* Special categories of cited documents :

- "A" document defining the general state of the art which is not considered to be of particular relevance
- "E" earlier application or patent but published on or after the international filing date
- "L" document which may throw doubts on priority claim(s) or which is cited to establish the publication date of another citation or other special reason (as specified)
- "O" document referring to an oral disclosure, use, exhibition or other means
- "P" document published prior to the international filing date but later than the priority date claimed

- "T" later document published after the international filing date or priority date and not in conflict with the application but cited to understand the principle or theory underlying the invention
- "X" document of particular relevance; the claimed invention cannot be considered novel or cannot be considered to involve an inventive step when the document is taken alone
- "Y" document of particular relevance; the claimed invention cannot be considered to involve an inventive step when the document is combined with one or more other such documents, such combination being obvious to a person skilled in the art
- "&" document member of the same patent family

Date of the actual completion of the international search 5 May 2020	Date of mailing of the international search report 14/05/2020
--	---

Name and mailing address of the ISA/ European Patent Office, P.B. 5818 Patentlaan 2 NL - 2280 HV Rijswijk Tel. (+31-70) 340-2040, Fax: (+31-70) 340-3016	Authorized officer Achermann, Didier
--	--

INTERNATIONAL SEARCH REPORT

Information on patent family members

International application No

PCT/GB2020/050386

Patent document cited in search report	Publication date	Patent family member(s)	Publication date
DE 102010054480 A1	14-06-2012	NONE	