

(19)



(11)

EP 2 484 239 A1

(12)

EUROPEAN PATENT APPLICATION

(43) Date of publication:

08.08.2012 Bulletin 2012/32

(51) Int Cl.:

A42C 2/00 (2006.01)

A42B 3/12 (2006.01)

(21) Application number: **12154042.1**

(22) Date of filing: **06.02.2012**

(84) Designated Contracting States:

**AL AT BE BG CH CY CZ DE DK EE ES FI FR GB
GR HR HU IE IS IT LI LT LU LV MC MK MT NL NO
PL PT RO RS SE SI SK SM TR**

Designated Extension States:

BA ME

(71) Applicant: **Dainese S.p.A.**

36060 Molvena (IT)

(72) Inventor: **Ronco, Luigi**

36060 Molvena, Vicenza (IT)

(74) Representative: **Manfrin, Marta et al**

Società Italiana Brevetti S.p.A.

Stradone San Fermo 21 sc. B

37121 Verona (VR) (IT)

(30) Priority: **08.02.2011 IT VR20110025**

(54) **Inner liner of a helmet, process to customize such an inner liner and helmet including such an inner liner**

(57) The present disclosure relates to an inner liner (10) of a helmet (12) interposed between a user's head (T) and a cap (14) of the helmet (12). The inner liner (10) includes a pad (24) comprising at least one first layer

(124) and at least one second layer (224), said second layer (224) being at least partially overlapped to said first layer (124) limitedly to defined zones of the first layer (124).

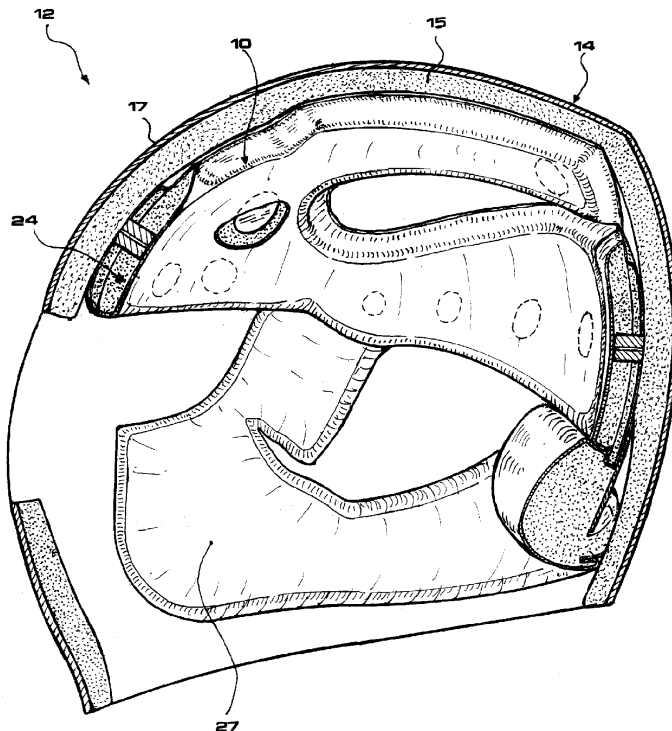

FIG.1

EP 2 484 239 A1

Description

[0001] The present disclosure relates generally to the technical field of protective helmets. More particularly, the present disclosure relates to an inner liner, conventionally also referred to as "interior", for a protection helmet, which is located inside an external cap of a helmet, and intended to be interposed between the cap and a user's head.

[0002] In particular, within the scope of the present description and in the claims hereinafter, by the term "inner liner" of a helmet it is meant a generally soft assembly which is for covering, at least partially, an internal or concave side of the cap (wherein said cap includes a shell and a polystyrene layer) and acting as soft layer or comfort layer between the cap and the head. Such inner liner can also comprise cheekbone guards.

[0003] More particularly, in the field of protective helmets, it is known that the external cap, conventionally made up of a shell and a polystyrene layer, has a substantially spherical shape, with a variable internal circumference depending on the head size or dimension. The liner has a predefined height depending on the internal circumference of the cap, and is such as to fill a gap between the internal circumference of the cap and the circumference of a user's head. Ultimately, the inner liner has a height depending on the difference of the average dimensions of head circumference and internal diameter of the cap, to fill the space between the rigid external cap and the head.

[0004] Such an inner liner, though advantageous under several standpoints, entails some drawbacks.

[0005] A drawback is, e.g., that with a known inner liner it is not always possible to provide an optimal comfort and at the same time stability to the helmet.

[0006] In fact, considering the variability in the anatomy of a user's head, it is not always possible to have a helmet in which the interior of the helmet can perfectly fill the space between the cap and the head.

[0007] In an attempt to overcome such a drawback, at times one has to choose a helmet of a smaller size in order to guarantee helmet stability to the detriment of comfort.

[0008] Sometimes instead, to have greater comfort and a less tight helmet, one has to choose a helmet of a larger size. In this case, however, in spite of the use of any strap or chin-strap the inner liner does not perfectly adhere to the head, and therefore the helmet is not perfectly stationary when worn on. Ultimately, there is the risk of a scarce stability of the helmet when it is worn on.

[0009] The technical problem at the basis of the present disclosure lies in providing an inner liner of a helmet and a helmet including such liner allowing to overcome at least one of the drawbacks mentioned hereto and/or providing some advantages. Such a technical problem is solved by an inner liner for helmets as defined in the independent claim 1 and by a helmet according to claim 8.

[0010] The present invention also relates to a method for customizing an inner liner for helmets, as defined in claim 12.

[0011] Secondary features of the subject of the present disclosure are defined in the corresponding dependent claims thereof.

[0012] In particular, thanks to the use of a pad which lines the cap and includes at least two overlapped layers wherein a second layer is at least partially overlapped to the first layer only limitedly to defined zones of the external cap (more precisely of the polystyrene layer) resting on the head, it is given the option of customizing the inner liner on the basis of certain needs, e.g. of anatomical nature, or for the aims to which the helmet is intended or for further contingent needs. In fact, it is possible to customize the pad by arranging the second layer only in defined zones of the liner, where greater resting is required. It follows that by increasing the number of layers and the relative arrangement of the second layer (or of further layers) with respect to the first layer, the customizing of the inner liner can be enhanced depending on the cap resting/comfort needs, and the pad stratification can be differentiated according to head zones.

[0013] E.g., in the zones of greater resting of the head T to the cap it is possible to increase the number of layers or change the material in order to have a greater compressive strength; whereas in zones in which greater comfort and lesser resting of the cap on the head T are required it may be useful to provide layers having a lower compressive strength, or a reduced number of layers.

[0014] Moreover, the inner liner according to the present disclosure allows to use, for a given range of sizes, a single cap of standard dimension, and vary the inner liner, customizing the inner liner on the basis of the size, or of a specific configuration of a user's head. In this regard, it could suffice to vary the two or more layers forming the pad.

[0015] It is therefore possible to customize an inner liner of a helmet starting from a customized mapping of a user's head in order to locate specific zones of the cap resting on the head.

[0016] In one embodiment, the pad is a multilayer structure with layers having thickness and/or differentiated material according to head zones.

[0017] In one embodiment, the inner liner is a sandwich structure including a first lining, a second lining, and the pad is included between the first lining and the second lining. This embodiment entails the advantage of being easy to manufacture, as well as that it is possible, in a simple way, to keep together the layers forming the pad.

[0018] Other features and the modes of use of the subject of the present disclosure will become clear from the following detailed description of some preferred embodiments thereof, provided by way of a non-limiting example. It is clear, however, that each embodiment may have one or more of the advantages listed above; in any case it is not required that each embodiment should have simultaneously all the advantages listed.

[0019] It is also to be understood that all possible combinations of the above-indicated embodiments, and of those described with reference to the following detailed description, fall within the scope of the present disclosure.

[0020] Reference will be made to the figures of the annexed drawings, wherein:

- Figure 1 shows an at least partially sectional side view, of a helmet including an inner liner according to the present disclosure;
- Figure 2 shows a side view of an inner liner for a helmet according to the present disclosure in a worn-on condition;
- Figure 3 shows a rear view of an inner liner for a helmet according to the present disclosure in a worn-on condition;
- Figure 4 shows a sectional view along line IV-IV of Figure 2;
- Figure 5 shows a sectional view along line V-V of Figure 2;
- Figure 6 shows a sectional view of a portion of inner liner according to a variant embodiment;
- Figure 7 shows a view with detached parts of a portion of inner liner for a helmet;
- Figure 8 shows a view with detached parts of a portion of inner liner for a helmet during a processing step.

[0021] Referring to the attached figures, by reference number 10 it is denoted an inner liner, also referred to as "interior", for a helmet 12 according to the present disclosure. The helmet 12 includes a rigid external cap 14, which includes a polystyrene layer 15 and a shell 17 of reduced thickness with respect to the polystyrene layer 15.

[0022] The inner liner 10 is adapted to be interposed between a user's head T and the cap 14. Therefore, such inner liner 10 is a generally soft structure intended to be bent to adhere to the shape of a user's head T. The inner liner 10 is fixed to the cap 14, e.g., by Velcro® snap fasteners or alike removable fixing means.

[0023] More particularly, in the example illustrated the inner liner 10 includes a pad 24 made of a soft and spongy material that partially lines the cap 14 and has open zones or cavities 26, allowing to keep the overall weight of the helmet 12 as reduced as possible, as well as facilitating aeration inside the helmet 12, or allowing ear accommodation.

[0024] In the example illustrated, the pad 24 includes appendages 27 which extend to the region of each cheekbone and mandible of a user, to form so-called cheekbone guards.

[0025] According to an aspect of the present disclosure, the pad 24 comprises at least two layers, i.e. a first layer 124 facing the user's head T and a second layer 224 facing the cap 14. The second layer 224 is at least partially overlapped to the first layer 124 limitedly to de-

fining zones of the first layer 124, e.g. in zones intended to support the polystyrene layer 15 of the rigid cap 14. In other words, the second layer 224 is only confined to some zones of the liner 10, in which the rigid cap 14 rests on the head T.

[0026] In the example, the second layer 224 is a layer which has a surface extension smaller than the first layer 124, so as to create a localized support zone for the rigid cap 14.

[0027] In one embodiment, the first layer 124 is different from the second layer 224 by thickness or height, and/or by material. I.e., the pad 24 is a mat having two or more layers at least partially overlapped, which are mutually different in thickness or height, and/or in material.

[0028] For instance, in the example illustrated, the first layer 124 is made of a material having a compressive strength smaller than the material of which the second layer 224 is made. Thus, there is a more rigid layer facing the cap 14 better able to bear the weight of the cap 14, and a softer layer facing the user, more suitable for contact with the head T.

[0029] As to the materials, e.g., the two layers 124, 224 may be made of foam, gel, polyurethane or polystyrene.

[0030] In the embodiment described, the inner liner 10 is a textile sandwich structure including a first lining 20, or external leather, a second lining 22, or internal leather, and the pad 24 of spongy material, included between the first lining 20 and the second lining 22. The pad 24 forms an inner core or kernel for the sandwich structure.

[0031] The first lining 20 and the second lining 22 are perimetrically connected in the region of respective edges projecting with respect to the core or pad 24, optionally by an edge ribbon, to keep the pad 24 stationary.

[0032] The first lining 20 and the second lining 22 are made of a so-called comfort fabric, e.g. of microfiber or of Lycra.

[0033] From the embodiment illustrated, it may be understood that between the two linings 20, 22 it is possible to arrange a number of layers even greater than two, in which the layers are different by surface extension, thickness and/or in material and/or by mutual arrangement (perfect overlapping or staggered layers) allowing to optimize the inner liner 10 according to needs, and according to the zone of the inner liner in which the pad 24 lies, e.g. differentiated between nape zone and forehead zone. In Figures 4-5 an example comprising only two layers 124, 224 is illustrated. In figure 6 an example including also a third layer 324 is illustrated. It is to be understood that the number of layers is variable according to the needs.

[0034] In other words, the inner liner 10 can be adapted by modifying the number of layers 124, 224 forming the pad 24, or the material or the related thickness of each layer with which the pad 24 is manufactured, according to the zones that such layers occupy on the head.

[0035] Moreover, it is observed that the inner liner 10

comprises one or more support inserts 25 inserted into corresponding holes 33, in the example pass-through holes, obtained in the pad 24, and therefore in both layers, and in the first lining 20.

[0036] The support inserts 25 have a further supporting or resting function, i.e. are able to support the cap 14 in the region of defined zones of the cap 14 resting on the head T.

[0037] In other words, the inner liner 10 includes a pad 24 of spongy material and support inserts 25, them also preferably made of spongy material, preferably having a compressive strength greater than the material of which the pad 24 is made, so as to act as further support for the cap 14 of the helmet 12.

[0038] The presence of the support inserts 25, which, as mentioned, support the cap 14, gives an improved stability to the helmet 12, in cooperation with the presence of at least two layers 124, 224. In fact, the position of the support inserts 25 can be selected on the basis of a shape of the user's head T (for example on the basis of the dimensions or peculiar anatomical features), actually freeing from a direct or strict correlation the dimensioning of the cap 14 and a user's dimension or head. From another standpoint, the support inserts 25 act as spacers so that the cap 14 keeps at a certain distance from the head T.

[0039] In the solution illustrated in the drawings, the support inserts 25 are made of a flexible cell structure such as, e.g., of foam. In alternative solutions, the support inserts 25 are made of gel, polyurethane, polystyrene.

[0040] In the embodiment described, four support inserts 25 are provided, arranged in the region of as many four points on the top of a user's head T, in particular two aligned in a top front zone (Figure 2) and two aligned in the top rear zone (Figure 3).

[0041] Moreover, it is observed that in the embodiment described the support inserts 25 or wedges have a cylindrical shape and are provided with internal pass-through holes 28 parallel to the cylinder axis.

[0042] Referring to Figure 8, the inner liner 10 is manufactured according to the following process.

[0043] The first lining 20 and the second lining 22 are provided, cut in a pattern according to the profile of inner liner 10 to be obtained.

[0044] The layers 124, 224 of the various materials forming the pad 24 are inserted between the first lining 20 and 22. The layers 124, 224 and the first lining 20 are provided with respective holes 33 for housing the support inserts 25.

[0045] Moreover, the first lining 20 and the second lining 22 are provided on the inner side with a film of glue, schematically drawn and denoted by reference number 120 in figure 8, and are placed under a press 60 to foster adhesion and mutual gluing. Thus, the pad 24 formed by the various layers and materials described is immobilized between the first lining 20 and the second lining 22.

[0046] The first lining 20 and the second lining 22 have a surface extension greater than the pad 24. In practice,

such perimetrical portions of the first lining 20 and of the second lining 22 are stably connected to each other, e.g. by glue or adhesive, along the entire perimetrical edge so as to contain the pad 24.

[0047] The first lining 20 and the layers 124 and 224 are moreover provided with holes 33 for the housing of the support inserts 25.

[0048] Optionally, the edge is subsequently trimmed and an edge ribbon is added.

[0049] This process for manufacturing the inner liner 10 allows to modify the materials and the layers of the pad 24 according to the needs, like e.g. according to the type of a protective helmet, e.g. motorcycle helmet, bicycle helmet, ski helmet, climbing helmet or other helmets as well as to vary at will the design of the inner liner. According to an aspect of the present disclosure, it is moreover noted that, thanks to the presence of the at least two layers 124, 224, the pad 24 can be modified in a customized and localized manner, e.g. by modifying the layer 224, according to the shape and size of a user's head.

[0050] In other words, by preferably varying the stratification and a distribution of the materials of the pad 24 according to head zones, it is possible to obtain an assortment of inner liners 10 different and customized for a single cap 14. Therefore, it is possible to obtain an adjustment of the size of a helmet and a greater comfort, thanks to the fact the position of the inserts and of the pad layers are selected depending on the shape and dimensions of a user's head.

[0051] The subject of the present disclosure has hereto been described with reference to preferred embodiments thereof. It is understood that there may be other embodiments referable to the same inventive concept, all falling within the protective scope of the claims set forth hereinafter.

Claims

1. An inner liner (10) of a helmet (12), said inner liner (10) being adapted to be interposed between a user's head (T) and a cap (14) of the helmet (12), said cap (14) including at least one internal layer (15) and an external shell (17), wherein said inner liner (10) comprises a pad (24) including at least one first layer (124) and at least one second layer (224), said second layer (224) being at least partially overlapped to said first layer (124) limitedly to defined zones of the first layer (124).
2. The inner liner (10) according to claim 1, wherein said second layer (224) faces the cap (14) and said first layer (124) faces the user's head (T) and wherein said second layer (224) has a surface extension smaller than said first layer (124).
3. The inner liner (10) according to claim 1 or 2, wherein

said first layer (124) differs from said second layer (224) by thickness or height, and/or by material.

4. The inner liner (10) according to any one of the preceding claims, wherein support inserts (25) are arranged in said first layer (124) and in said second layer (224). 5
5. The inner liner (10) according to any one of the preceding claims, having a textile sandwich structure and including a first lining (20), a second lining (22) and said pad (24), wherein said pad (24) is included between the first lining (20) and the second lining (22). 10
6. The inner liner (10) according to any one of the preceding claims, wherein at least said second layer (224) varies in material and/or thickness depending on the zone on which it lies on said first layer (124). 15
7. The inner liner (10) according to any one of the preceding claims, wherein said pad (24) has weight-lightening openings (26). 20
8. A helmet (12) including a cap (14) and an inner liner (10) according to any one of the preceding claims. 25
9. The helmet (12) according to claim 8, including a single rigid cap (14) and an assortment of inner liners (10) according to any one of the preceding claims, said inner liners (10) being different from one another. 30
10. The helmet (12) according to any one of the preceding claims 8 or 9, wherein the internal layer (15) of the cap is a layer of polystyrene. 35
11. The helmet (12) according to any one of the preceding claims 8 to 10, wherein the pad (24) is associated to the cap by removable fastening means. 40
12. A method for customizing an inner liner (10) for a protection helmet (12), wherein said inner liner (10) is adapted to be associated to a rigid cap (14) of the protection helmet (12), said cap (14) including a shell (17) and an internal layer (15), said method comprising the steps of 45
 - performing a mapping of a user's head (T) to locate zones of the internal layer (15) of the cap (14) resting on the head (T); 50
 - providing a pad (24) adapted to line at least partially the internal layer (15), wherein said pad (24) includes at least one first layer (124) and at least one second layer (224); 55
 - arranging the second layer (224) on the first layer (124) limitedly to defined zones of the first layer (124) in the region of said zones of the

internal layer (15) resting on the head (T).

13. The method according to claim 12, wherein said second layer (224) is set facing the cap (14) and said first layer (124) is set facing the user's head (T), and wherein said second layer (224) differs from said first layer (124) by thickness or height, and/or by material.
14. The method according to claim 12 or 13, wherein, without changing the cap (14), a first inner layer is replaced (10) with a second inner liner (10), said second inner liner (10) being different from the first inner liner (10) at least on the basis of a number, distribution, height and/or material of at least one of the layers (124, 224) forming the pad (24).

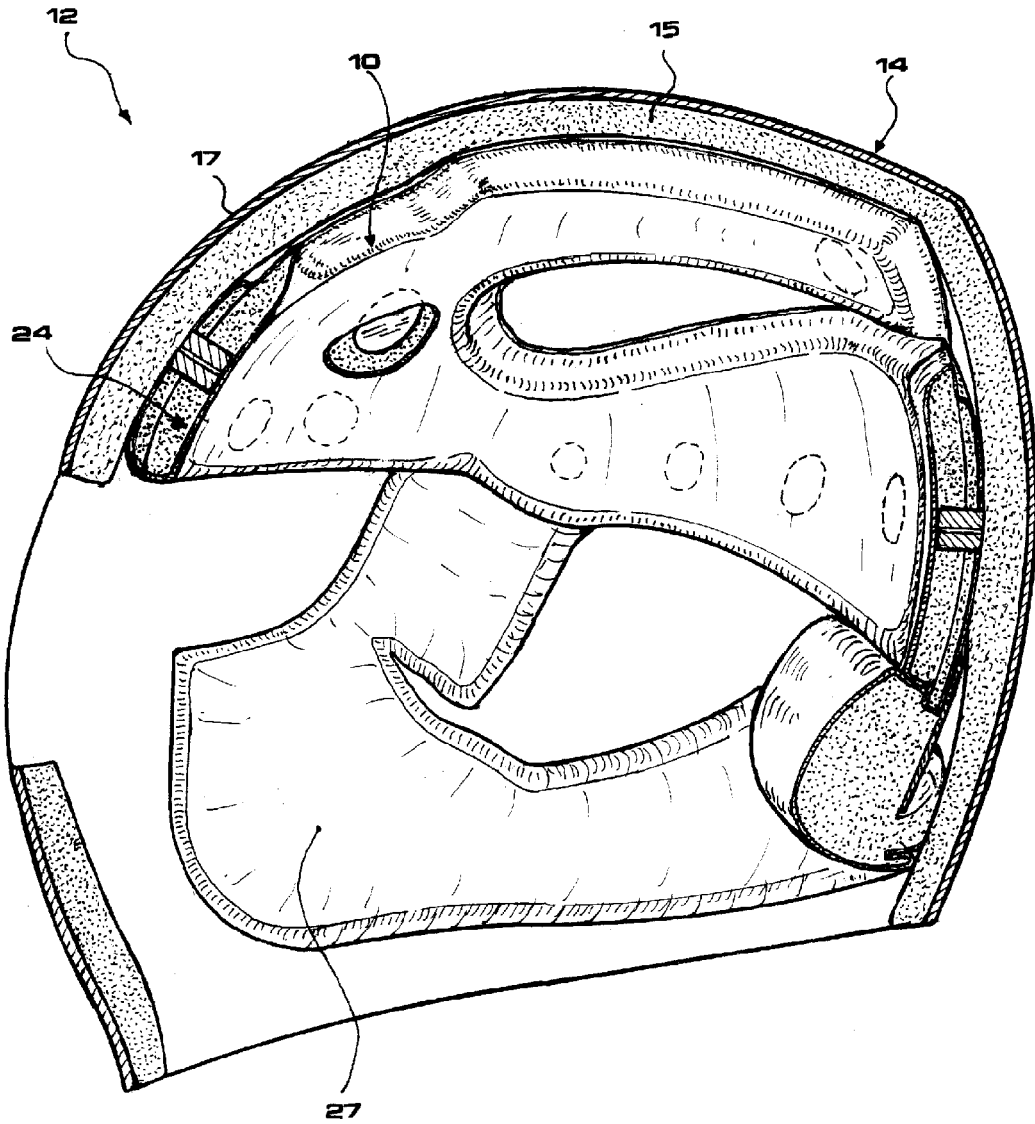

FIG.1

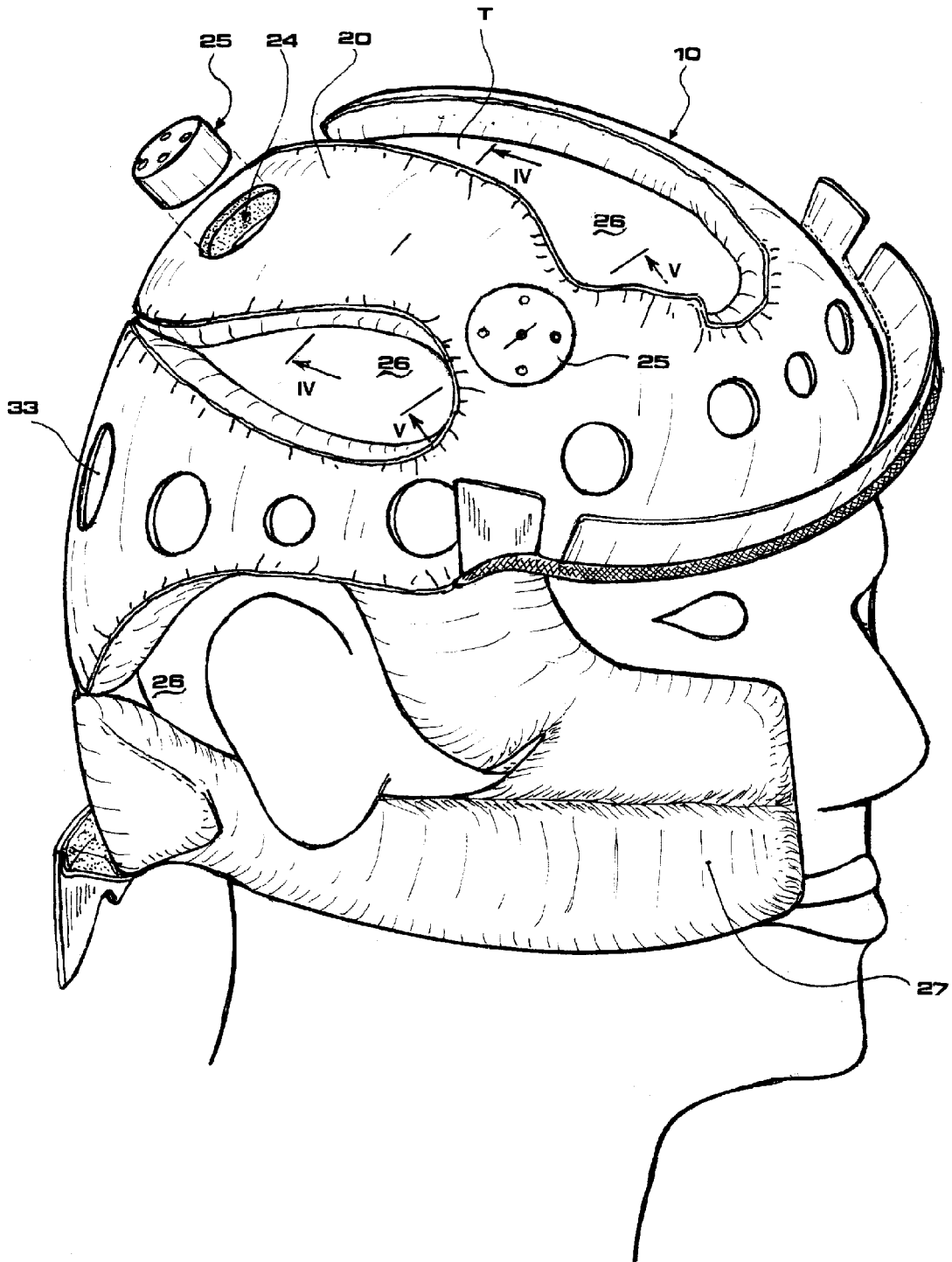

FIG. 2

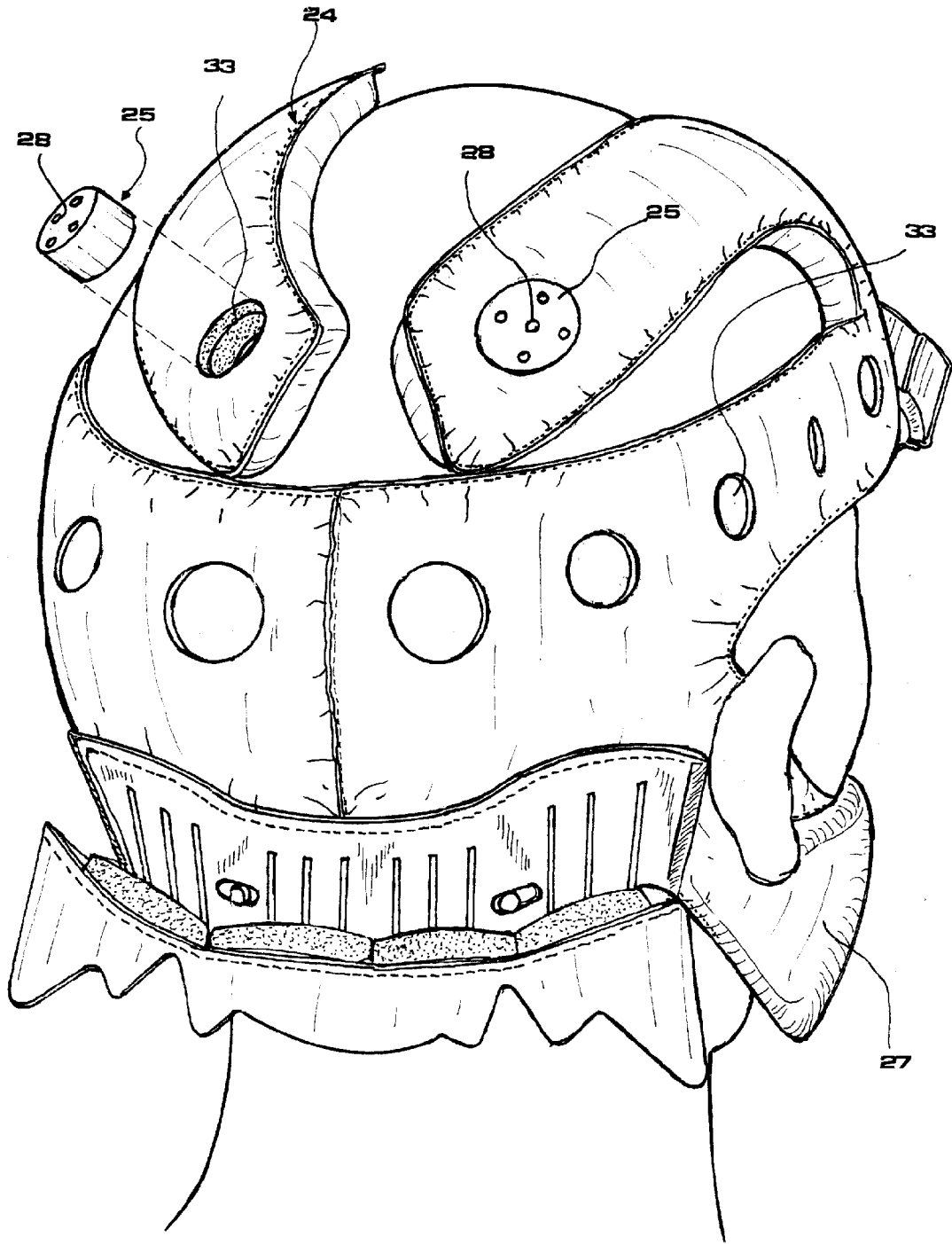

FIG.3

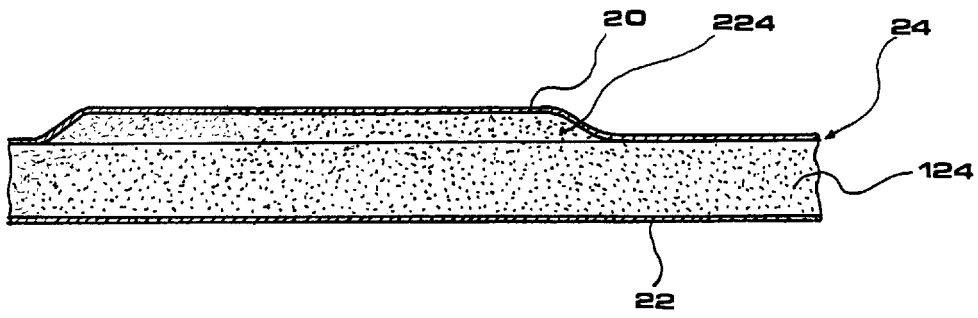

FIG. 4

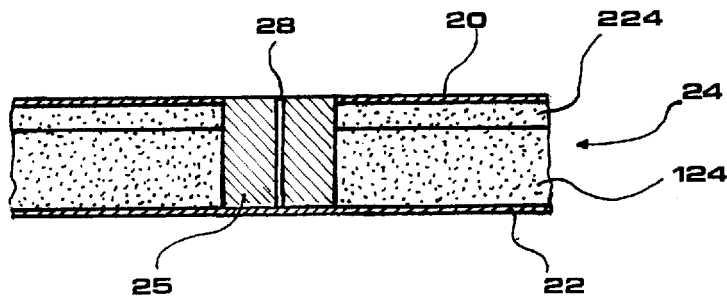

FIG. 5

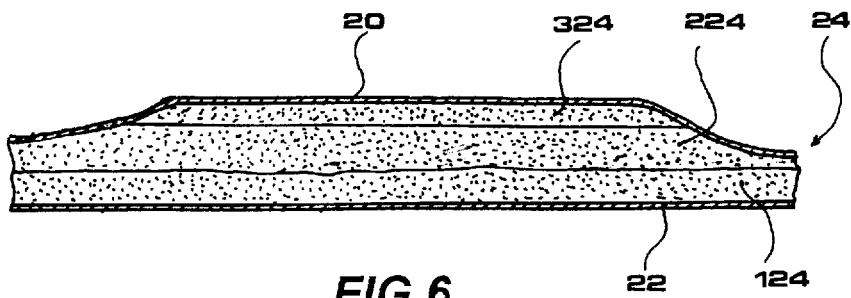
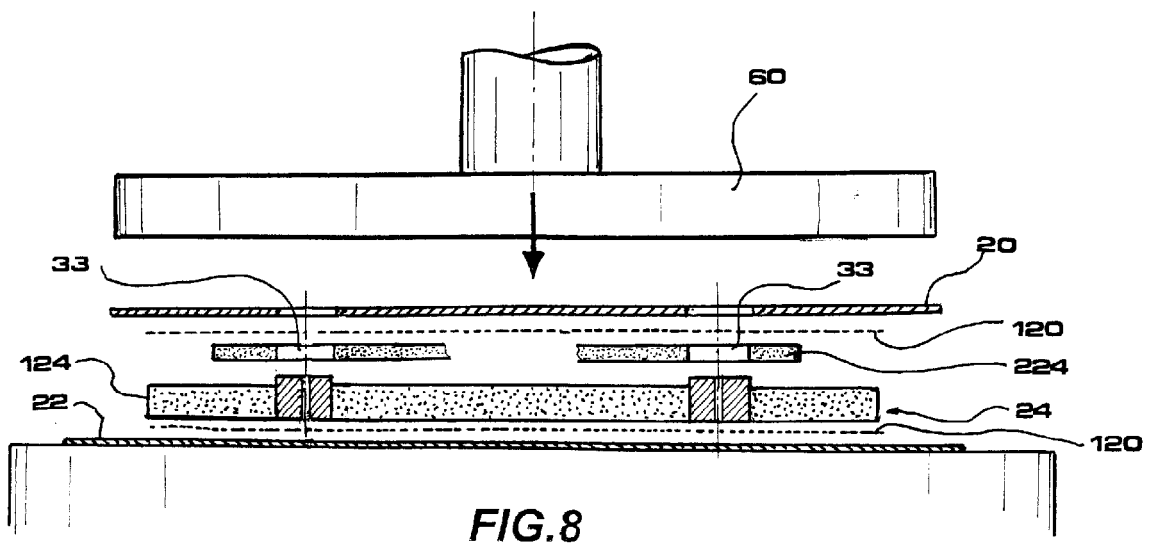
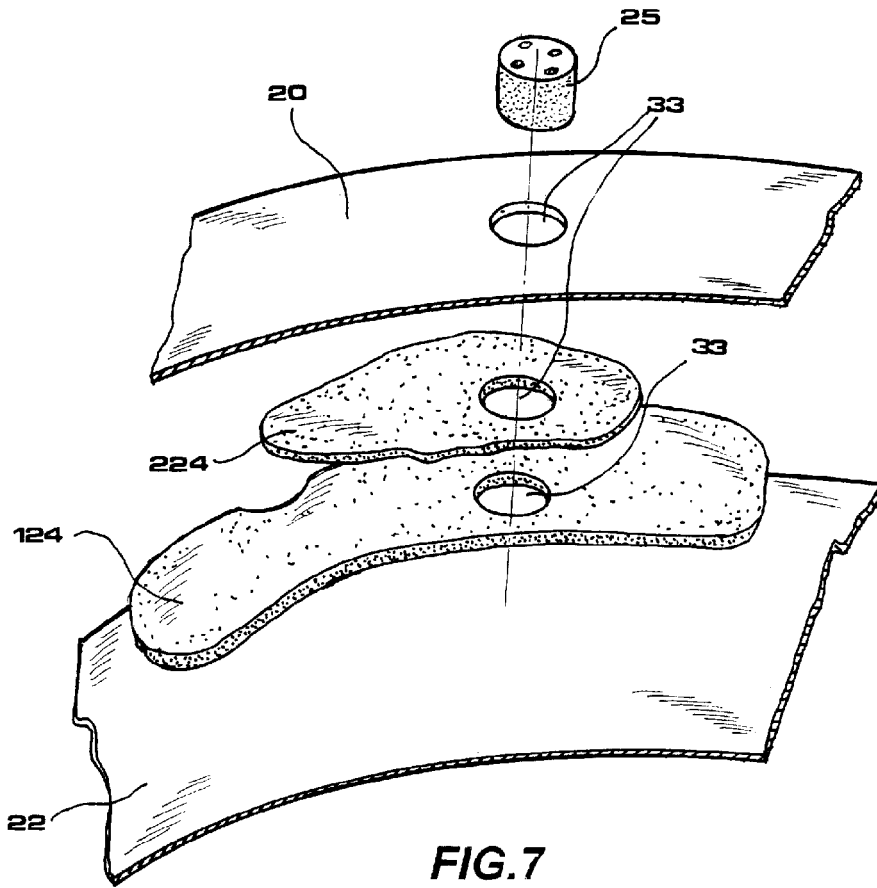

FIG. 6





EUROPEAN SEARCH REPORT

Application Number
EP 12 15 4042

DOCUMENTS CONSIDERED TO BE RELEVANT			
Category	Citation of document with indication, where appropriate, of relevant passages	Relevant to claim	CLASSIFICATION OF THE APPLICATION (IPC)
X	US 4 345 338 A (FRIEDER JR LEONARD P ET AL) 24 August 1982 (1982-08-24)	1-4, 6-10, 12-14	INV. A42C2/00 A42B3/12
Y	* column 1, line 40 - line 42 * * column 2, line 66 - column 3, line 42 * * figure 3 *	5,11	
Y	----- JP H06 54735 U (.) 26 July 1994 (1994-07-26) * figures 4,5,7 *	5,11	
X	----- WO 2004/071223 A2 (MACHO PRODUCTS INC [US]) 26 August 2004 (2004-08-26) * figures 3,4 * -----	1-3,8	
			TECHNICAL FIELDS SEARCHED (IPC)
			A42C A42B
The present search report has been drawn up for all claims			
Place of search		Date of completion of the search	Examiner
The Hague		23 April 2012	Guisan, Thierry
CATEGORY OF CITED DOCUMENTS		T : theory or principle underlying the invention E : earlier patent document, but published on, or after the filing date D : document cited in the application L : document cited for other reasons & : member of the same patent family, corresponding document	
X : particularly relevant if taken alone Y : particularly relevant if combined with another document of the same category A : technological background O : non-written disclosure P : intermediate document			

2
EPO FORM 1503 03.82 (F04C01)

**ANNEX TO THE EUROPEAN SEARCH REPORT
ON EUROPEAN PATENT APPLICATION NO.**

EP 12 15 4042

This annex lists the patent family members relating to the patent documents cited in the above-mentioned European search report. The members are as contained in the European Patent Office EDP file on
The European Patent Office is in no way liable for these particulars which are merely given for the purpose of information.

23-04-2012

Patent document cited in search report		Publication date	Patent family member(s)	Publication date
US 4345338	A	24-08-1982	NONE	

JP H0654735	U	26-07-1994	-----	
WO 2004071223	A2	26-08-2004	NONE	
