

E. L. HAYWARD.
 TRACK MOVING MACHINE.
 APPLICATION FILED APR. 29, 1911.

1,000,908.

Patented Aug. 15, 1911.

7 SHEETS—SHEET 1.

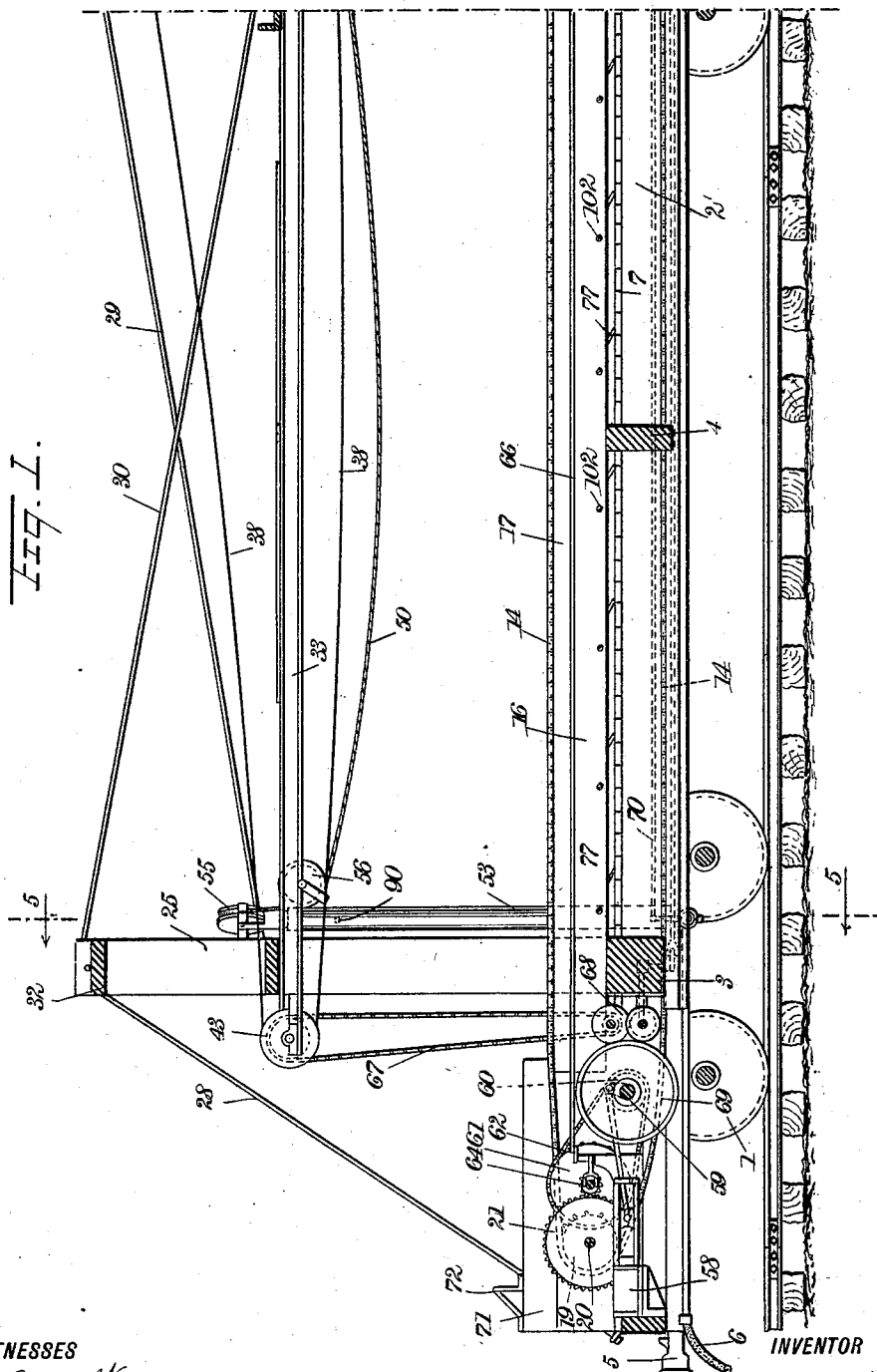

WITNESSES
H. J. Walker
L. J. Gallagher

INVENTOR
E. L. Hayward
 BY *Mumford*
 ATTORNEYS

E. L. HAYWARD.
 TRACK MOVING MACHINE.
 APPLICATION FILED APR. 29, 1911.

1,000,908.

Patented Aug. 15, 1911.

7 SHEETS—SHEET 2.

Fig. 2.

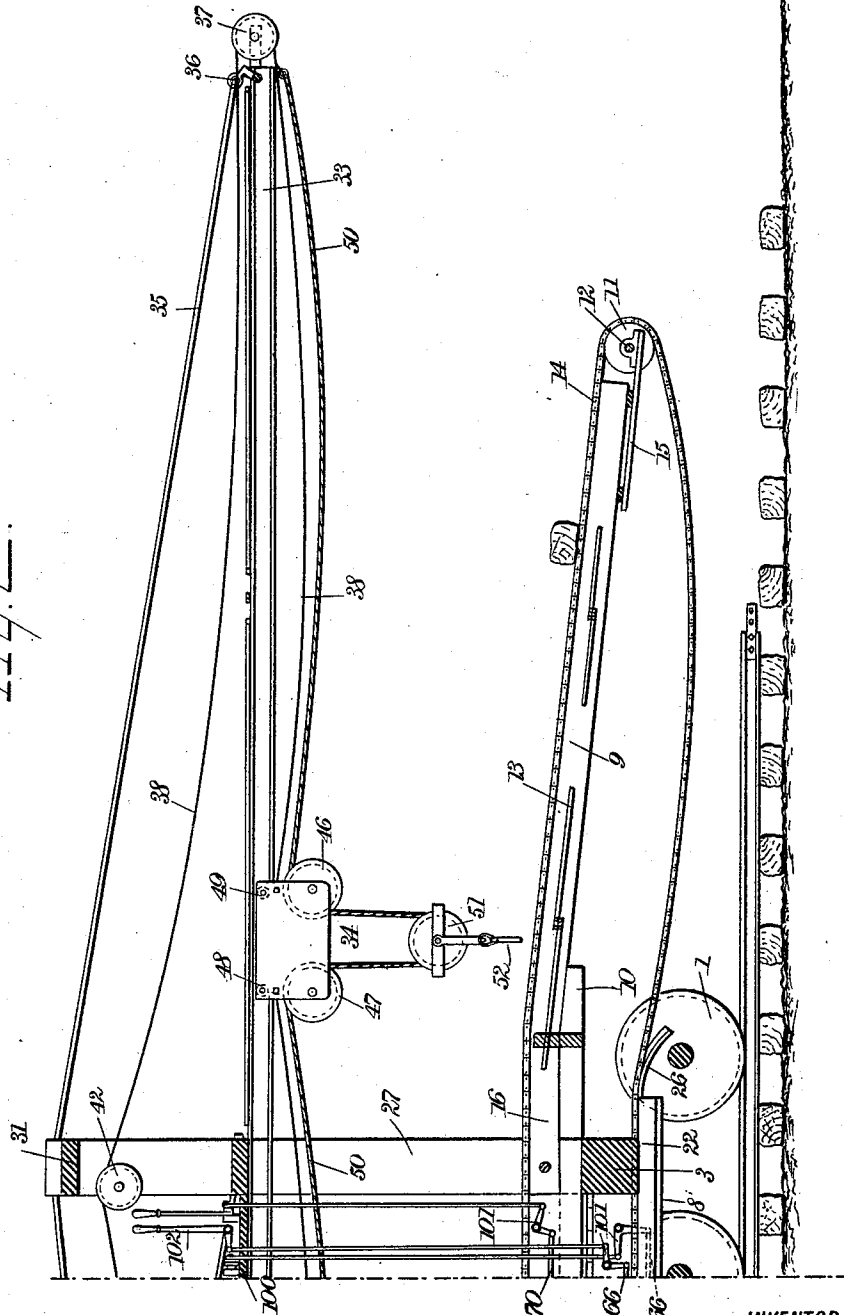

WITNESSES
H. J. Walker
L. J. Gallagher

INVENTOR
Elmer L. Hayward
 BY *Mumford*
 ATTORNEYS

E. L. HAYWARD.
 TRACK MOVING MACHINE.
 APPLICATION FILED APR. 29, 1911.

1,000,908.

Patented Aug. 15, 1911.

7 SHEETS—SHEET 3.

Fig. 3.

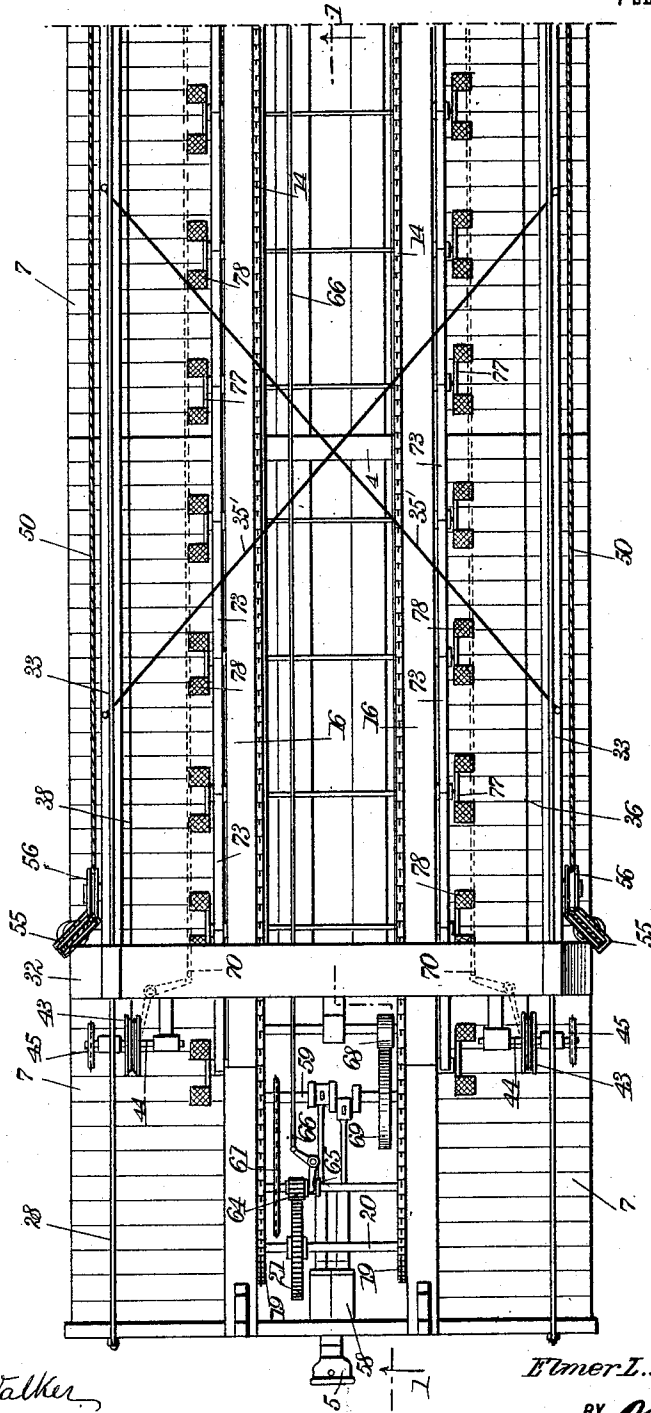

WITNESSES
H. J. Walker
L. J. Gallagher

INVENTOR
E. L. Hayward
 BY *Mumford*
 ATTORNEYS

E. L. HAYWARD.
 TRACK MOVING MACHINE.
 APPLICATION FILED APR. 29, 1911.

1,000,908.

Patented Aug. 15, 1911.

7 SHEETS—SHEET 4.

FIG. 4.

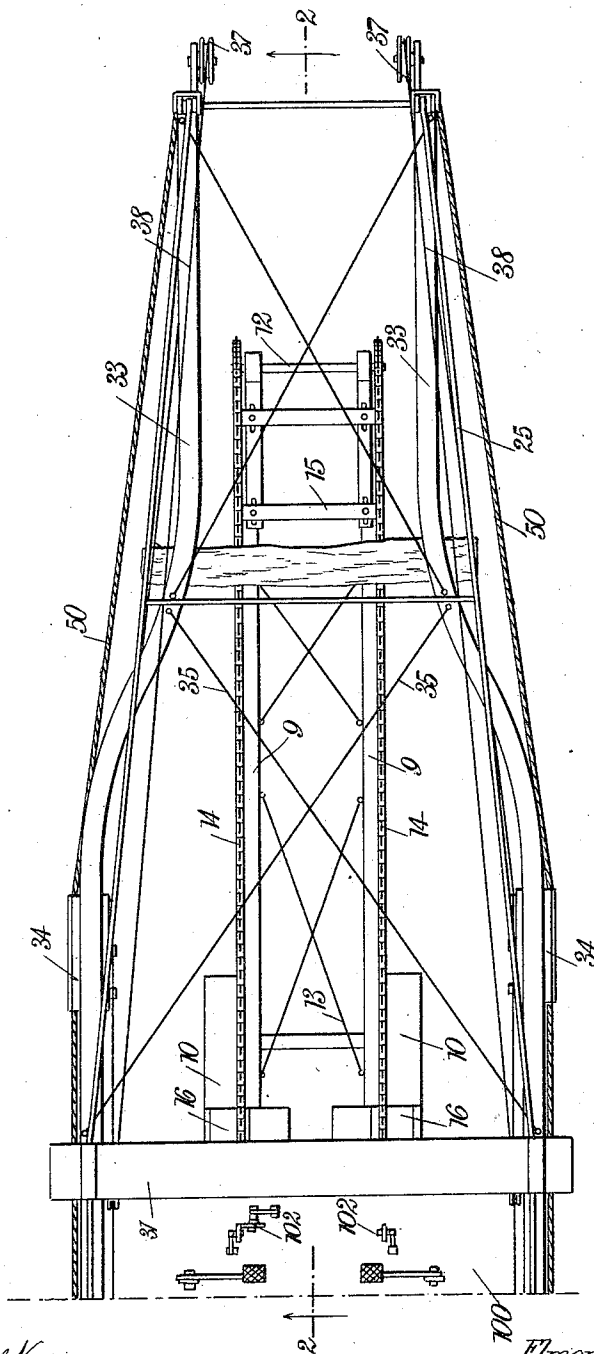

WITNESSES
H. J. Walker
L. J. Gallagher

INVENTOR
Elmer L. Hayward
 BY *Mumford Co.*
 ATTORNEYS

E. L. HAYWARD.
 TRACK MOVING MACHINE.
 APPLICATION FILED APR. 29, 1911.

1,000,908.

Patented Aug. 15, 1911.

7 SHEETS—SHEET 5.

Fig. 5.

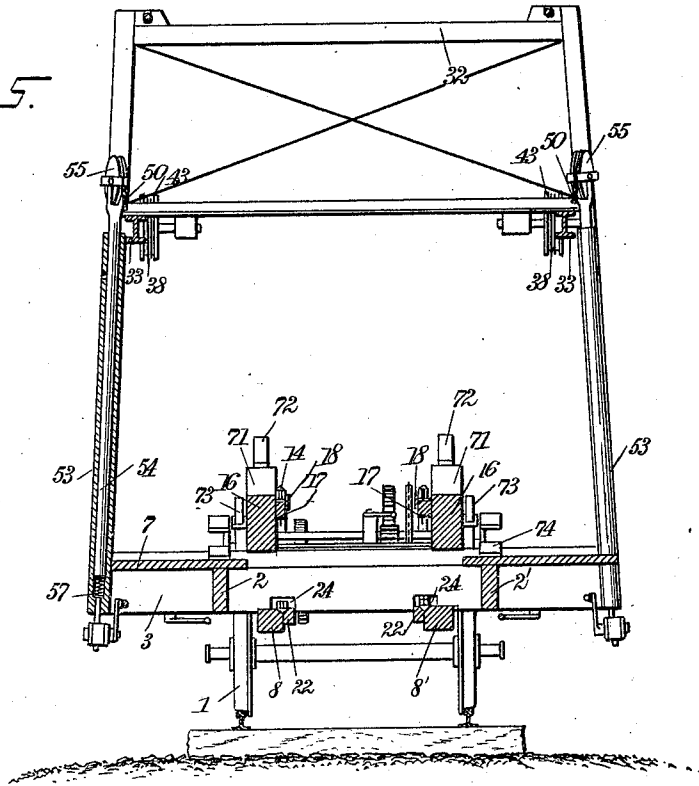
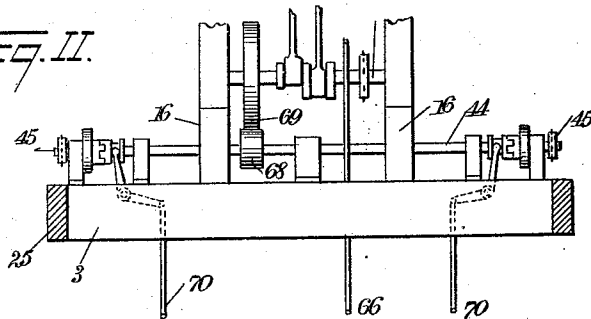

Fig. 11.



WITNESSES
H. J. Walker.
L. J. Gallagher.

INVENTOR
Elmer L. Hayward
 BY *Mymileo*
 ATTORNEYS

E. L. HAYWARD.
 TRACK MOVING MACHINE.
 APPLICATION FILED APR. 29, 1911.

1,000,908.

Patented Aug. 15, 1911.

7 SHEETS—SHEET 6.

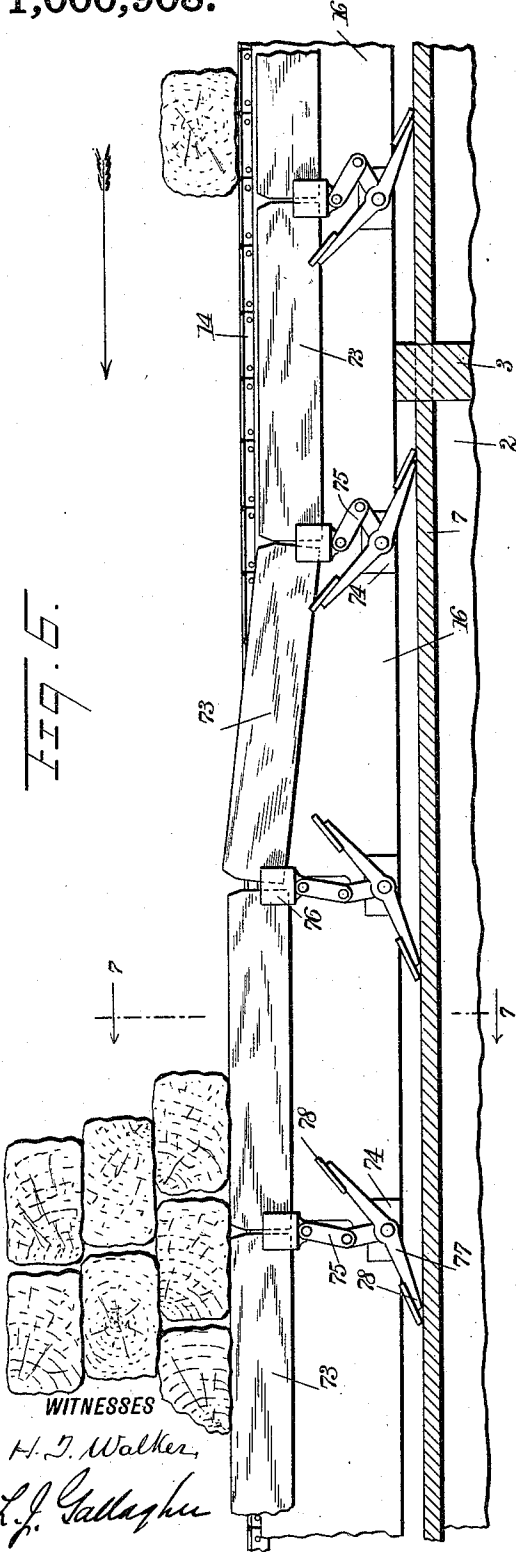

WITNESSES
 H. J. Walker,
 L. J. Gallagher

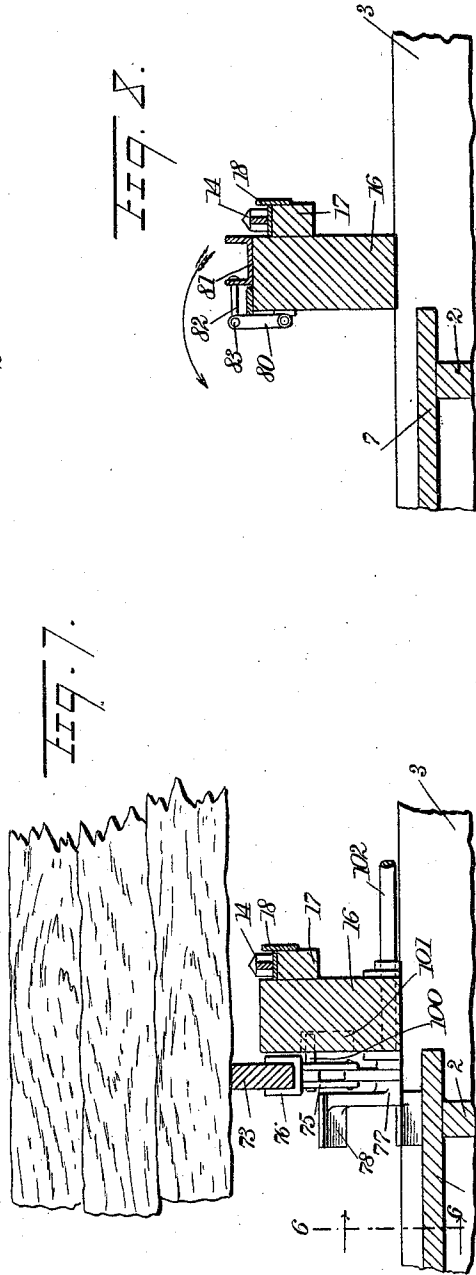

INVENTOR
 Elmer L. Hayward
 BY *Mumford*
 ATTORNEYS

E. L. HAYWARD.
 TRACK MOVING MACHINE.
 APPLICATION FILED APR. 29, 1911.

1,000,908.

Patented Aug. 15, 1911.

7 SHEETS—SHEET 7.

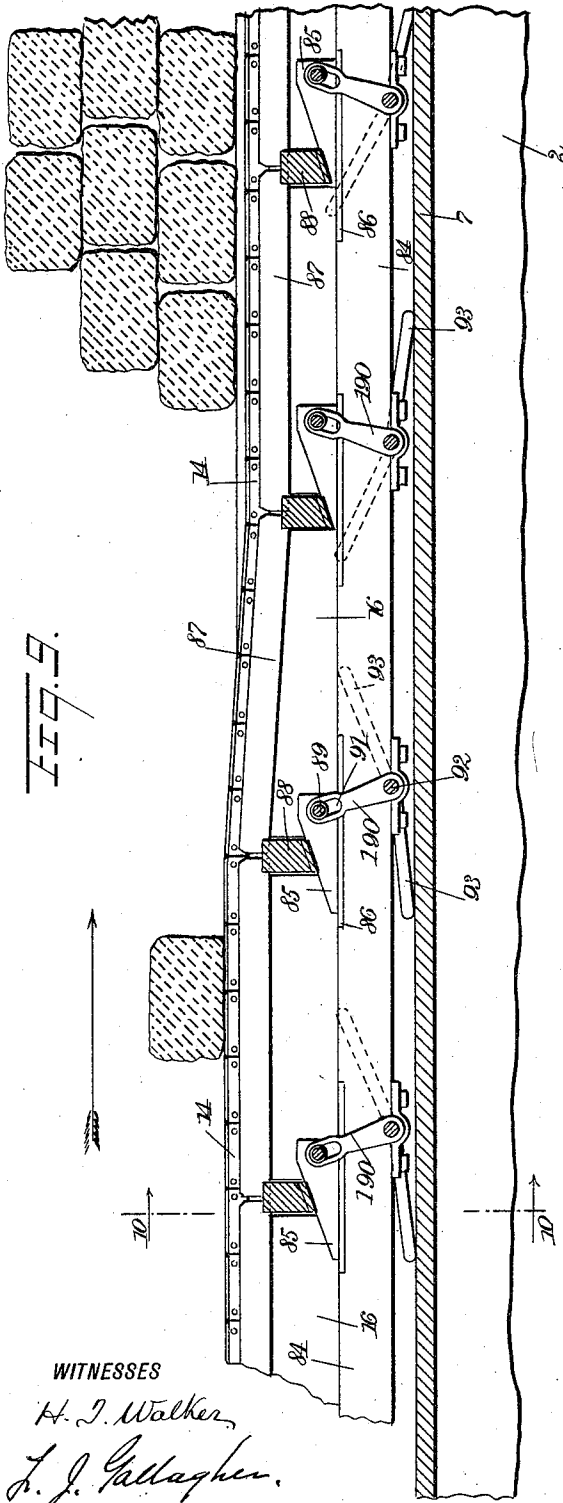

FIG. 9.

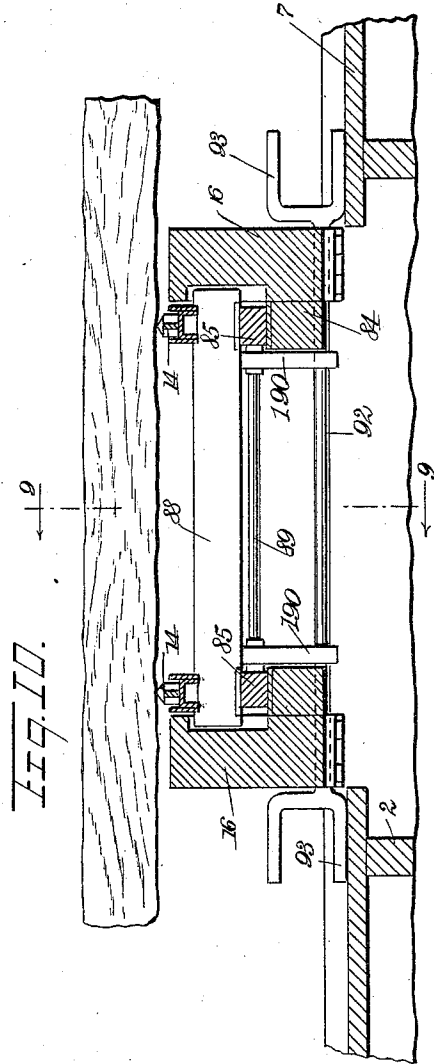

FIG. 10.

WITNESSES
H. J. Walker,
L. J. Gallagher.

INVENTOR
Elmer L. Hayward
 BY *Mumford*
 ATTORNEYS

UNITED STATES PATENT OFFICE.

ELMER LELAND HAYWARD, OF DAVENPORT, IOWA.

TRACK-MOVING MACHINE.

1,000,908.

Specification of Letters Patent. Patented Aug. 15, 1911.

Application filed April 29, 1911. Serial No. 623,995.

To all whom it may concern:

Be it known that I, ELMER L. HAYWARD, a citizen of the United States, and a resident of Davenport, in the county of Scott and State of Iowa, have invented a new and Improved Track-Moving Machine, of which the following is a full, clear, and exact description.

The invention relates to improvements in means or apparatus employed in handling steel and ties in track construction.

The object of the invention is to provide a means, or apparatus, for use especially in timber lands, whereby the handling and transportation of track material is facilitated.

The means or apparatus consists generally of a flat car structure on which devices for handling rails and ties are suitably mounted; the car is also designed to carry these rails and ties, suitable means being provided whereby practically all of the available space is utilized.

The structure embodying my invention is particularly adapted for use in timber operations, or on large plantations, in fact in any locality where tracking is laid, used for a time and then taken up to be again laid in another place. Economical operation requires that substantially all track material be kept in use and that the labor available is sufficient to be constantly employed; these ends may be accomplished by providing facilities for taking up and relaying track in a given time equal in amount to the tracking no longer needed by reason of clearing certain areas of timber or plantation within that time. It is with such object in mind that I have devised the construction herein shown, which construction I shall hereafter refer to as a track moving machine.

Machines for picking up and transporting sections or panels of track, which include rails and ties fastened together, are well-known; the disadvantage in the use of such machines lies in the fact that a large part of tracking used in timber clearing is laid in curves, or turn-outs, some of which turn to the right and some to the left, so that after a turn-out is taken up it is generally necessary to remove the rails from the ties in order to adapt the turn-out to its new location; these machines being adapted for panels and not for rails and ties separately, it becomes necessary to break up the panels

after being carried by these machines to their new location.

In my apparatus I provide separate devices for rails and ties; separate provision is made for taking care of each of these articles, the construction being such that all available space is utilized.

The machine is provided with suitable power devices, control of which is brought to a platform so that one operator may observe all working thereby obtaining maximum efficiency.

The rails and ties are brought adjacent the machine by manual labor; the machine then takes care of the lifting and moving to position for stacking.

Reference is to be had to the accompanying drawings forming a part of this specification, in which like characters of reference denote corresponding parts in all the views, and in which—

Figure 1 is a vertical sectional view of the rear end of the machine taken on the line 1—1 of Fig. 3; Fig. 2 is a similar view of the front end thereof, taken on the line 2—2 of Fig. 4; Fig. 3 is a top plan view of the rear end; Fig. 4 is a similar view of the front end; Fig. 5 is a transverse sectional view, on the line 5—5 of Fig. 1; Fig. 6 is a partial longitudinal sectional view, on the line 6—6 of Fig. 7, showing the means whereby the ties may be supported on the machine; Fig. 7 is a partial transverse sectional view on the line 7—7 of Fig. 6; Fig. 8 is a partial transverse sectional view showing a modification of the device shown in Figs. 6 and 7; Fig. 9 is a partial longitudinal sectional view, on the line 9—9 of Fig. 10, showing a further modification of the device shown in Figs. 6, 7, and 8. Fig. 10 is a transverse sectional view on the line 10—10 of Fig. 9; Fig. 11 is a partial plan view of the rear end of the machine showing details of the clutches and driving mechanism.

Referring particularly to Figs. 1 to 5 inclusive, I provide a flat car of any desired length supported at either end on suitable trucks, the number of wheels 1 in each of which will depend on the size of the machine and the weight which it is designed to carry, as well as the weight and length of the rails. The frame of the car may be made up of longitudinally extending floor beams 2, 2', together with suitable transverse beams 3, 3', adjacent the ends thereof,

intermediate beams 4 being also provided. The rear end of the frame is provided with the usual coupler 5 whereby the machine may be connected to a locomotive; together
 5 with a suitable hose or flexible connection 6 whereby steam may be supplied to the engine of the machine if it is desired to operate the same with a steam engine. The car
 10 floor 7 extends preferably throughout the length of the car and is suitably attached to the beams 2, 2', the central portion of the car between these beams being preferably
 15 open. Of course the detail construction of this car may vary widely, depending on the uses to which the machine is to be put and on the material of which it is made.

The forward end of the car is provided with extending cantalivers 9 suitably supported on a shaft by the frame of the car,
 20 whereby the cantalivers may be moved up and down from the track, a pulley 11 is provided at the outer end of each of the cantalivers, these pulleys being supported on a suitable shaft 12. The cantalivers
 25 may be maintained in rigid relation by means of suitable braces 13 extending between them. The pulleys 11 are designed to change the direction of motion of an endless chain 14 carried by the car and to the
 30 end that this drive may be maintained in proper tension I have shown the pulleys 11 mounted on suitable bearing members 15 which are adjustable along the outer end of the cantalivers, as shown particularly in
 35 Fig. 4. The endless drive is designed to take care of the ties which are delivered to the machine to be stored thereon, or to take care of delivering the ties to the end of the machine when it is desired to lay out new
 40 track, and the construction and operation of this drive may be explained as follows. Extending longitudinally of the machine and preferably at equal distances from the center thereof are two stringers 16, having
 45 on their adjacent sides tracks 17, designed to support the chain 14, the position of this chain on the tracks being maintained by means of suitable irons 18 secured to the tracks on the outer side thereof whereby a
 50 passageway is secured for the chain. This chain extends the length of the machine and may be moved in either direction, the chain being supported on the outer end of the cantalivers by the pulleys 11; as previously
 55 described, and at the rear end of the machine by suitable pulleys 19 carried on a shaft 20 to which a gear 21 is attached whereby power may be applied to this shaft. The return movement of this chain or device
 60 is provided for by suitable members 22 extending throughout the length of the machine and on the under side thereof, being preferably secured to the longitudinally extending members of the car frame 8, 8',
 65 shown particularly in Fig. 5; the top por-

tions of each beam and each member 22 may preferably be provided with a longitudinally extending groove or recess whereby the chain may rest on these parts while
 70 traveling; the chain may pass under the beams 3, 3', or a portion thereof may be removed in order to accommodate the chain, and I have shown the transverse beam 3 provided with suitable openings 24 in order to
 75 enable the chain to pass therethrough. If desired, the forward end of the chain under the cantaliver 9 may be suitably supported, such support depending principally on the length of the cantalivers used; suitable
 80 guides 26 are provided at the forward ends of the frame members 8, 8', whereby the chain may be directed in its movement under the car.

In order to take care of the rails and move the same from the front end of the car to
 85 other portions thereof where they may be stored during transit, I have provided suitable trolleys having a grapple thereon for engaging the rails, the structure of which I will now set forth. At the four corners of
 90 the floor of the machine and preferably at the ends of the main transverse beams 3, 3', thereof, I provide suitable uprights 25, 27, held in position by means of rods 28, 30, and 29, 35; each pair of uprights may also
 95 be suitably supported by transversely extending members 31, 32. Extending beyond the length of the machine at the forward end thereof and at a suitable height are the
 100 trussed frames which are preferably made up of I-beams 33, and rods 35, which frames are designed to support trolleys 34, these I-beams extending preferably throughout the major portion of the machine, being
 105 supported at their rear ends by the uprights or posts 25 and cross-beam 32 in any suitable manner, the outer end of each of the I-beams being in engagement with the aforesaid rods 35 secured thereto by means
 110 of a suitable clevis 36, the other end of these rods being secured to each of the uprights 25; the intermediate portions of the I-beams are maintained in position by the cross-rods 35'. Each of these I-beams is provided
 115 at its outer end with a suitable pulley 37 designed to support a power cable or equivalent device 38, one end of which is attached to one end of the trolley 34, the other end being also attached to this trolley, the intermediate portions of the cable
 120 extending to the rear end of the machine and being wrapped around suitable pulleys 42, 43; each of the pulleys 43 is suitably supported on a shaft 44 on which a suitable sprocket wheel or equivalent device 45 is
 125 carried, whereby power may be applied to the pulley in order to move the cable, thereby bringing the trolley 34 from one end of the machine to the other. This trolley is preferably provided with suitable means
 130

for taking up portions of the power cable 38 in the event of stretching thereof by use; roller bearings 48, 49, are also preferably provided in order to make the movement along the I-beams as frictionless as possible.

5 Secured to the outer end of each of the cantalivers 33 is a rope or cable 50 which extends to the rear portion of the machine, over the pulleys 46, 47, of the trolley and supporting the sheave 51 which depends therefrom, a suitable rail tongs 52, being carried by the sheave and adapted to be raised or lowered by movement of the rope or cable 50, this movement being effected as follows. At the rear portion of the machine and preferably at opposite sides thereof are cylinders 53, each having a piston 54 which is movable therein, the upper end of the piston being provided with a suitable pulley 55, over which the rope or cable 50 passes, being guided thereto by means of an idler 56, the end of the cable being secured to any suitable portion of the frame of the machine. Each of the pistons 54 is operable by pressure applied to the interior of the cylinders 53, which pressure is preferably that of steam, so that as the pistons rise the sheave 51 and lifting tongs 52 will be elevated, the trolley 34 being then brought to the desired position along the length of the machine by means of the cable 38, the sheave and tongs being again lowered by reducing the pressure behind the pistons 53, suitable springs 57 being provided within the cylinders in order to take care of the shock of the falling piston. It is to be noted that these cylinders adjacent the upper ends thereof are provided with escape ports 90 whereby the piston may be held in position, a slight escape of steam being permitted thereby; such an arrangement permits of control of the machine by inexperienced labor. Of course it is obvious that in place of the cylinders I may use a friction driven drum.

At the rear end of the car and suitably positioned at a central portion thereof is the engine 58 which may be driven by any power but preferably by steam from the locomotive coupled to the machine, the engine being in engagement with a shaft 59 through suitable means, the shaft being also provided with a sprocket 60 in engagement with another sprocket 61 through a driving chain 62, this sprocket 61 driving the gear 21, previously mentioned. The pinion 64 is adapted to be thrown into and out of engagement with the gear 21 by means of a suitable clutching mechanism 65 operable through a lever 66 extending to the operating platform to be later described. The pulleys 43 which operate the power cables 38 are also designed to be operated by means of this engine 58 by means of suitable chains 67 driven by a friction clutch 68

adapted to be thrown into or out of engagement with the wheel 69 carried on the power shaft 59; these friction drives, or it may be clutching devices, as shown in Fig. 11, may be thrown into or out of operative position by suitable levers 70, operable from the same platform previously mentioned, as the engine 58 may be a continuously running one, if desired, the devices which are operated by this engine being controlled from this platform.

The rail tongs 52 are of a construction suited to lifting rails and the opposite floor portions of my machine throughout the length thereof are adapted to support these rails during transportation, it being noted that the I-beams 33 which support the trolleys are directly over these side portions of the machine, the distance between them at the outer ends thereof, however, being preferably the gage of track to be laid, whereby the rails may be individually carried back and forth and deposited in proper position on the ties when laying track.

Storage of the rails is taken care of in the following manner; referring particularly to Fig. 5 it will be noted that the top of the endless chain 14 is above the top of the longitudinally extending stringers 16 whereby when a number of ties are placed on the top of this chain at the forward end of the car they will be moved to the rear of the car, there being no obstructions to this movement of the ties. At the rear end of the machine the stringers 16 terminate in shorter pieces 71, having bumpers 72 positioned therein, these shorter pieces being adapted to support a number of ties removed from the engine devices of the machine; when the ties have been piled to a desired height on these pieces 71 the remaining ties are stacked along the length of the machine and over the stringers 16, a plurality of movable rests 73, shown particularly in Fig. 6, being provided which operate in the following manner: A number of bearing blocks 74 are suitably spaced along the length of the car and adjacent the outer side of each of the stringers 16, each block supporting suitable toggles 75, each of the toggles serving to raise and lower a holding member 76, each member supporting the end portions of adjacent movable rests 73, shown particularly in Fig. 6. Each toggle is operable by a suitable double lever 77, carried on a suitable shaft 102, and each has foot plates 78 at opposite ends thereof whereby the rests 73 may be elevated and held in such elevated position by pressing downwardly on one of these foot rests; each toggle is preferably provided with a laterally extending pin 100 engaging in a suitable slot 101 in the side of the stringer 16, whereby the relation of the parts is secured.

It will be noted that each of the rests 73 when in operative position and supporting a number of ties extend above the top of the chain 14 whereby the ties are supported out of contact with the chain. By the use of this mechanism I am enabled to store any number of ties throughout the length of the machine by simply operating the toggles 75, the ties being carried along the chain and being stacked in position on these rests; as the loading of the ties progresses each of these rests is brought into raised position and ties placed thereon so that when they have all been brought into such position the machine has taken care of a large number of ties, the free running of the chain not being interfered with. In the place of the means just described for supporting the ties out of engagement with the chain drive, I may provide another means for accomplishing the same purpose which is shown in Fig. 8. In this construction the stringers 16 have a number of levers 80 pivotally secured to their outer faces, each of these levers being in engagement with a channel-iron 81, through a suitable link 82, which is pivotally connected at 83 to the lever 80; the height of the channel-iron 81 is such that when in the position shown in Fig. 8 the top portion thereof will be above the top of the chain 14 whereby the ties may be stacked as previously described. These channel-irons or, as I have termed them previously, rests, are brought into operative position by being moved by hand, the levers 80 supporting them in inoperative position adjacent the outer face of the stringers 16. Either of these means accomplish the same result and in some cases one may be preferable to the other, depending on the cost of the complete machine.

In Figs. 9 and 10 I have set forth a further construction for providing for the stacking of the ties above the chain and out of contact therewith, this construction differing from what has been previously described in that the chain is moved rather than the rests. Each of the stringers 16 is preferably of L-formation, the lower portion 84 thereof providing a suitable bearing for a number of movable wedges 85, plates 86 being provided on which these wedges may ride if desired. In this instance the chain 14 is carried on a number of supporting members 87 extending along the sides of the stringers 16, a plurality of transversely extending elements 88 supporting adjacent ends of these supporting members 87, as shown particularly in Fig. 9, the under side of each of the elements 88 being in engagement and resting on the inclined face of each of the wedges 85. Opposite wedges are connected together by means of a rod 89, each rod being engaged at opposite end portions thereof by a lever 190

having a slot 91 therein within which the rod is engaged, these levers 190 being carried by a transversely extending shaft 92, to the outer end portions of which a foot lever 93 is secured; the normal position of the chain in this construction is as shown at the left hand portion of Fig. 9, the top of the chain being above the top of the stringer 16 whereby a tie may be carried along by the chain and lengthwise of the car. When it is desired to stack the ties on top of the stringers 16 one end of the foot lever 93 is pressed downwardly whereby the wedge 85 is moved to the rear and the chain 14 is allowed to fall below the top of the stringers, whereby the ties may be placed thereon as shown at the right hand portion of Fig. 9; it is obvious that as the ties are stacked in position successive foot levers 93 will be depressed, whereby the chain 14 may be lowered, thereby providing a space for stacking more ties until the entire length of the chain is in such position when the machine has been fully loaded. This construction for taking care of the disposition of the parts in order to allow this stacking of the ties may be used in place of either of the two forms previously described, the use of either being largely a matter of choice but being also determined by the relative costs.

The handling of the rails has been previously described and it has also been noted that the rail carrying means is at opposite side portions of the machine whereby the rails may be placed on the machine and stacked thereon without interfering in any way with the operation of stacking the ties.

The size of my machine as a whole and its height will be determined largely by the cost thereof and by the uses to which it is to be put, but, in any event, in order to facilitate the operation of the machine as a unit and to bring supervision thereof under the control of a single director, I have provided a suitable platform adjacent the forward end of the machine and adjacent the top thereof, whereby an individual control of the various parts of the machine is secured. This platform 100 is preferably positioned just above the longitudinally extending I-beams 33, in fact these I-beams may provide a suitable support for the platform if desired, the various levers 66, 70, being conducted thereto through suitable bell crank levers 101, each of the levers being operated by hand levers 102; it will thus be seen that a single operator has these hand levers under his control and is in a position to oversee the operation of the machine and apply the power to the different parts thereof, whereby the operation of the unit is rendered more efficient, and a large amount of work may be accomplished in a short time.

In the use of my machine in taking up tracking it is gradually moved along the track as the same is taken up so that the necessity of carrying rails or ties is done away with, the manual labor necessary being merely to disconnect the rails from each other and to withdraw the spikes from the ties; the grapple 52 is conveniently positioned to be extended the desired distance beyond the end of the machine in order to pick up and place the rails in their proper place on the machine; while the rails are thus being taken care of the ties are fed continuously to the moving chain which carries them back on the machine and into position for stacking.

The operation of the various parts and the relation to each other have been explained as the description of the construction has proceeded so that the operation is believed to be set forth and not to require a further exposition.

When the machine has been brought to the place where the tracking and ties are to be relaid the reverse operations are gone through; the chain is driven in the opposite direction and the ties are carried out to the end thereof and deposited on the ground to be later placed in proper position; the trolleys pick up the rails and deposit them along the end portions of the ties which are on the ground so that it is unnecessary to carry these rails any distance; as track is laid the machine is moved forwardly thereover until all the ties and rails have been placed on the ground when it may be brought to another place to pick up and move other sections of track.

While I have shown an engine of a particular type as the prime mover for the tie carrying means and the rail carrying means, it is obvious that any suitable prime mover, such as an electric motor, or gasolene engine, or a compressed air engine, could be used for this purpose; it may also be desirable in some instances to provide driving means between this prime mover and the trucks of the car so that as the car moves gradually along the track in the laying thereof, such movement effected by this prime mover, in which case and for which purpose, the locomotive could be detached from the machine and be used in other localities.

While the description of the various parts of my machine has been rather specific and certain details have been set forth, the inventive idea involved is not limited by such details of construction or by such specific forms, the purpose of my invention being satisfied by a machine which has individual means for picking up rails and ties, and provisions thereon for storing them in order to provide a structure having cooperating parts, each performing its own function, the operation of the whole, however, tending to

a unitary result, namely, the moving of a track.

Having thus described my invention, I claim as new, and desire to secure by Letters Patent:—

1. A track moving machine embodying a car structure having thereon means for moving ties from one end of the structure to the other, means whereby the ties may be stacked adjacent the said moving means and out of contact therewith, together with independent means for moving rails from one end of the car to the other, suitable means being also provided whereby the tie moving means and rail moving means may be suitably operated.

2. A track moving machine embodying a car structure having thereon endless moving chains adapted to carry ties from one end of the structure to the other, means whereby the ties may be stacked adjacent the said moving means and out of contact therewith, together with separate means for moving rails from one end of the structure to another portion thereof, the structure being provided with suitable power devices for operating the rail moving means or the moving chains independently of each other.

3. A track moving machine embodying a car structure having thereon endless chains for carrying ties with means for moving the said chain, a plurality of means for moving rails from one end of the structure to other portions thereof, suitable power devices being provided whereby either the endless chains or the rail moving means may be operated independently of each other, the rail moving means extending longitudinally of the said structure and substantially in the same vertical plane as the rails on which one side of the said car structure rests at the forward end thereof.

4. A track moving machine embodying a car structure having moving means thereon for carrying ties from one end of the structure to the other, a suitable framework for supporting moving trolleys which are adapted to pick up and move rails, power devices being provided for actuating the said trolleys or the said moving means for handling the ties independently of each other, the said moving chain extending along a substantially central portion of the said car structure and the said trolleys being positioned on either side of and above the said tie moving means whereby rails and ties may be independently moved into position on the said structure for storage thereon.

5. A track moving machine embodying a car structure having cantalivers extending from the front end thereof, there being endless chains supported adjacent the floor of the said structure and longitudinally of the said cantalivers, whereby ties may be moved lengthwise of the car, I-beams extending

longitudinally of the car and beyond the forward end thereof, the said I-beams being positioned above the said moving chain, together with means movable along the said I-beams for picking up and moving rails, together with means for operating the said endless chain or the said rail lifting means independently of each other.

6. A track moving machine embodying a car structure having endless chains thereon adjacent the floor thereof, the said floor having forwardly extending cantalivers over which the said chains pass, the said chains being movable whereby ties may be brought from the end of the cantalivers to the floor of the car, I-beams extending longitudinally of the car and beyond the forward end thereof and at a suitable height above the floor of the car, trolleys movable along each of the said I-beams, together with means on each of the said trolleys for picking up and moving rails, suitable power means being provided for actuating the endless chain or the said trolleys independently of one another, whereby the ties and rails used in track construction may be separately taken care of.

7. A track moving machine embodying a car structure having thereon an endless chain, means for moving the said chain whereby ties laid thereon may be moved from one end of the car to the other, movable means suitably supported adjacent each of the said chains, together with other means for elevating the said means whereby they may be placed in position with their upper portion higher than the said chains, whereby the ties may be stacked in position on the said means and out of engagement with the said chains.

8. A track moving machine embodying a car structure having an endless chain thereon, together with means for moving the said chain whereby ties may be moved from one end of the structure to the other, suitable rests carried by the structure adjacent each of the said chains, the said rests being movable into position above the said chains and held in such position whereby the ties may be stacked thereon out of engagement with the said moving chains, the said structure being also provided with independently moving means for picking up and moving rails.

9. A track moving machine embodying a car structure having stringers thereon extending through the length thereof, the said stringers being extended beyond the forward end of the car in the shape of cantalivers, endless chains supported by the said stringers and cantalivers, together with means for moving the said chains whereby ties may be placed on the chains and may be brought into position on the said car for stacking thereon, suitable rests being movably supported on each of the stringers ad-

jacent each of the chains, together with means for moving the said rests whereby they will stand at a higher elevation than the said chains, the said ties being adapted to be stacked on top of the said rests, thereby providing for further operation of the chain, suitable power devices being provided whereby the said endless chain may be moved.

10. A rail handling machine embodying a car structure having a number of uprights carried thereby, I-beams extending the length of the structure and supported by the said uprights, suitable braces being provided whereby rigidity is secured, trolleys movable along the said I-beams and provided with suitable means for lifting steel rails, other means being provided for moving the said trolleys along the said I-beams, an endless chain adjacent the floor of the car and extending beyond the forward end thereof, the said means for operating the said trolleys being also adapted to operate the said endless chain, there being suitable rests movably supported adjacent each of the chains, the said rests being adapted to be held in position above the said chains whereby ties which are moved along the structure by the said chain may be stacked in position on the structure and on the said rests, whereby the said chains may operate free of engagement therewith.

11. A track moving machine embodying a car structure having endless chains thereon, together with means for moving the said chains whereby ties may be moved from one end of the structure to the other, a plurality of rests carried by the structure adjacent each of the said chains, together with means engaging adjacent ends of successive rests, operation of the said means raising the said adjacent ends above the said chains whereby the ties may be stacked thereon out of engagement with the said chain.

12. A track moving machine embodying a car structure having endless chains thereon, together with means for moving the chains whereby ties may be moved from one end of the machine to the other, a plurality of rests carried by the structure adjacent each of the said chains, a plurality of holding members between the machine and the rests, each of the holding members supporting adjacent ends of successive rests whereby when one holding member is raised, the rests supported thereby are moved with their upper sides above the said chains, thereby enabling the ties to be stacked thereon and out of engagement with the said moving chain.

13. A track moving machine embodying a car structure having endless chains thereon, together with means for moving the said chains whereby ties may be moved from one end of the machine to the other, a plurality of rests, a plurality of holding members,

each holding member engaging and supporting adjacent ends of successive rests, each holding member being supported by the floor of the machine through a suitable toggle, whereby operation of the toggle will raise the said holding members and the rests supported thereby into position above the chains and hold them in such position, thereby enabling a number of ties to be stacked on the rests without interfering with the movement of the chains.

14. A track moving machine embodying a car structure having endless chains thereon, together with means for moving the chains, whereby ties may be moved from one end of the structure to the other, a plurality of rests carried by the machine and adjacent each of the said chains, a plurality of holding members also carried adjacent each of the chains, each of the holding members engaging and supporting adjacent ends of successive rests, a plurality of transversely extending shafts carried by the machine, a toggle at each end of each shaft, each toggle being in engagement with opposite holding members whereby a turning movement of the shaft will raise opposite holding members and the rests carried thereby and will carry them above the said chains and hold them in such position, thereby enabling a

number of ties to be stacked on the rests and free of engagement with the moving chains.

15. A track moving machine embodying a car structure having endless chains therein, together with means for moving the chains, whereby ties may be moved from one end of the structure to the other, a plurality of rests carried by the structure and adjacent each of the chains, each holding member supporting adjacent ends of successive shafts, a plurality of transversely extending shafts carried by the structure, a toggle at each end of each shaft, each toggle engaging opposite holding members, a hooked plate carried at each outer end of each shaft, whereby movement of the plate will turn the shaft and will operate the toggles, thereby moving the toggles and bringing the rests above the moving chains and holding them in such position, thereby enabling a number of ties to be stacked on the rests and out of engagement with the said chain.

In testimony whereof I have signed my name to this specification in the presence of two subscribing witnesses.

ELMER LELAND HAYWARD.

Witnesses:

LAURENCE J. GALLAGHER,
PHILIP D. ROLLHAUS.