

(19) World Intellectual Property Organization
International Bureau



(43) International Publication Date
23 July 2009 (23.07.2009)

PCT

(10) International Publication Number
WO 2009/090473 A1

- (51) International Patent Classification:
A61M 1/16 (2006.01) A61M 1/34 (2006.01)
- (21) International Application Number:
PCT/IB2008/003504
- (22) International Filing Date:
16 December 2008 (16.12.2008)
- (25) Filing Language: English
- (26) Publication Language: English
- (30) Priority Data:
MI2007A002397
20 December 2007 (20.12.2007) IT
- (71) Applicant (for all designated States except US): **GAMBRO LUNDIA AB** [SE/SE]; Box 101 01, S-22010 Lund (SE).
- (72) Inventors; and
- (75) Inventors/Applicants (for US only): **VINCI, Luca** [IT/IT]; no. 79, viale Martiri della Libertà, I-46025 Poggio Rusco (IT). **ROSSI, Andrea** [IT/IT]; no. 169/B, via Cantone, I-46020 San Giacomo Delle Segnate (IT).

- (74) Agent: **PONZELLINI, Marco**; Gambro Legal and Intellectual Property Dept., P.O. Box 98, I-41037 Mirandola (IT).
- (81) Designated States (unless otherwise indicated, for every kind of national protection available): AE, AG, AL, AM, AO, AT, AU, AZ, BA, BB, BG, BH, BR, BW, BY, BZ, CA, CH, CN, CO, CR, CU, CZ, DE, DK, DM, DO, DZ, EC, EE, EG, ES, FI, GB, GD, GE, GH, GM, GT, HN, HR, HU, ID, IL, IN, IS, JP, KE, KG, KM, KN, KP, KR, KZ, LA, LC, LK, LR, LS, LT, LU, LY, MA, MD, ME, MG, MK, MN, MW, MX, MY, MZ, NA, NG, NI, NO, NZ, OM, PG, PH, PL, PT, RO, RS, RU, SC, SD, SE, SG, SK, SL, SM, ST, SV, SY, TJ, TM, TN, TR, TT, TZ, UA, UG, US, UZ, VC, VN, ZA, ZM, ZW.
- (84) Designated States (unless otherwise indicated, for every kind of regional protection available): ARIPO (BW, GH, GM, KE, LS, MW, MZ, NA, SD, SL, SZ, TZ, UG, ZM, ZW), Eurasian (AM, AZ, BY, KG, KZ, MD, RU, TJ, TM), European (AT, BE, BG, CH, CY, CZ, DE, DK, EE, ES, FI, FR, GB, GR, HR, HU, IE, IS, IT, LT, LU, LV, MC, MT, NL,

[Continued on next page]

(54) Title: A MEDICAL APPARATUS FOR EXTRACORPOREAL TREATMENT

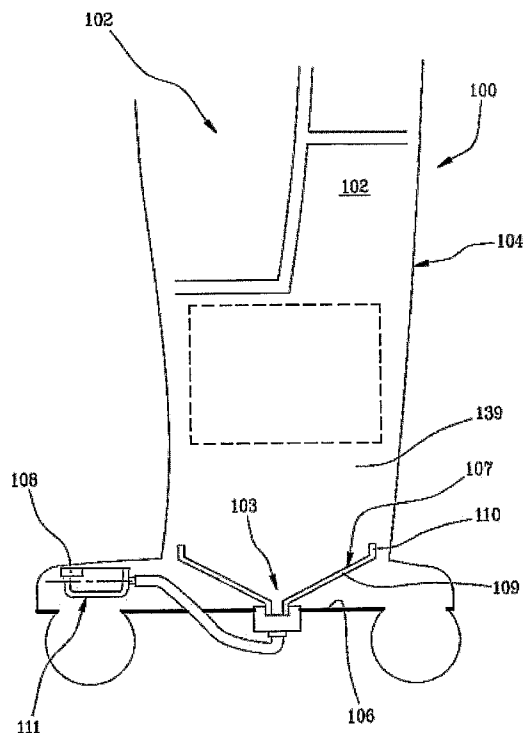

FIG 3

(57) Abstract: A medical apparatus (100) for extracorporeal blood treatment comprises a support structure (101) housing a hydraulic circuit (1) located above a liquid collection zone (103) such that liquid losses from the hydraulic circuit can at least partially accumulate at the liquid collection zone. A liquid sensor (108) detects presence of any liquid in the liquid collection zone and operates in a distanced position with respect to the liquid collection zone (103).

WO 2009/090473 A1



NO, PL, PT, RO, SE, SI, SK, TR), OAPI (BF, BJ, CF, CG,
CI, CM, GA, GN, GQ, GW, ML, MR, NE, SN, TD, TG).

Published:
— *with international search report*

- 1 -

A MEDICAL APPARATUS FOR EXTRACORPOREAL TREATMENT

D e s c r i p t i o n

5 As is known, machines for blood treatment, such as for
example machines for kidney failure or hepatic
insufficiency treatments, or machines for
plasmapheresis or machines for other treatments, can
10 comprise a hydraulic circuit which has the task of
removing one or more liquids from a source, taking
those liquids towards a treatment zone and removing the
used liquid or liquids downstream of the treatment zone
in order to evacuate them towards a discharge zone.

15 By way of example, in machines for treatment of chronic
kidney failure, one or more liquid sources contribute
to form a fresh treatment liquid which is taken from a
channel towards a treatment zone. In particular, the
treatment zone comprises one or more semipermeable
20 membrane treatment units where the treatment liquid
exchanges solid and liquid substances with the blood
subjected to treatment. The most typical therapies are
hemodialysis, hemofiltration, hemodiafiltration,
ultrafiltration and plasmapheresis. Machines for kidney
25 failure treatment can carry out one or more of the
above-listed treatments.

Downstream of the treatment unit or units, a discharge
channel takes the used treatment liquid towards one or
30 more discharges.

The hydraulic circuit briefly described above comprises
numerous components, such as: pumps, valves, tubes,
sensors etc., which are connected to one another. It is
35 thus obvious that during use of the machine, an

- 2 -

undesirable liquid leak from the hydraulic circuit might occur at one or more of the junctions between the various components, or due to breakage of one or more components. In the dialysis sector, due to the
5 continuous treatment cycles, the variability of the pressures, the disinfection cycles, seal problems can emerge over time, due to wear.

Although the hydraulic circuits are clearly designed to
10 guarantee optimal functioning in all operating conditions, it is obvious that possible liquid leakage can occur over the lifespan of a machine for blood treatment. It is also clear that possible liquid leaks, apart from causing undesirable losses of material, can
15 damage the dialysis machine and can be dangerous for the patient undergoing treatment. If for example excessive liquid leakage impinges on components sensitive to contact with liquid, the components might be irreparably damaged, compromising the operativity of
20 the whole machine. If these leaks were to go unnoticed, they might compromise control of the fluid balance in the patient, with possible consequences for the well-being of the patient him or herself.

25 A known technical solution in the sector of dialysis is described in patent US5674390, in which a dialysis machine exhibits a shaped bottom housing, at the lowest point thereof, a liquid leakage sensor.

30 A second known solution is illustrated in document WO2004096322 which concerns a device for detecting leakage in dialysis machines constituted by a container which collects leakage and two liquid level sensors.

35 Finally, documents GB2199436 and GB2272553 describe

- 3 -

devices for detecting fluid loss from apparatus located above them. The described devices comprise shaped bottoms with a zone of maximum depth where the leaked fluid collects, the zone being located in a central zone of the bottom, or a corner zone thereof.

An aim of the invention is to make available an easily-implemented medical apparatus for extracorporeal blood treatment which can reliably detect liquid leakage.

10

A further aim of the invention is to make available a medical apparatus for extracorporeal blood treatment in which maintenance and/or inspection of the liquid sensor or sensors used is easy.

15

A further aim of the invention is to make available a medical apparatus where the liquid sensor or sensors do not operate in direct contact with the liquid.

20 A further aim of the invention is to make available a medical apparatus which can switch to a security mode in a case of liquid leakage.

One or more of the specified aims is attained by a medical apparatus for extracorporeal blood treatment, comprising:

- a support structure internally exhibiting a housing chamber including at least one liquid collection zone;
- a hydraulic circuit having at least one supply channel, destined to transport a treatment liquid from at least one source towards a treatment station, and at least one discharge channel, destined to transport a used liquid from the treatment station towards an evacuation zone, the hydraulic circuit being located in the housing chamber above the liquid collection zone

35

- 4 -

such that the leakage of liquid from the hydraulic circuit can in part accumulate at the liquid collection zone,

5 - a liquid sensor destined at least to detect any liquid in the liquid collection zone, characterised in that the liquid sensor operates in a distanced position with respect to the liquid collection zone.

10 The support structure exhibits at least one lateral wall substantially delimiting the housing chamber and a bottom arranged in a lower portion of the support structure and comprising at least the liquid collection zone; the liquid sensor is located in a position which is distanced from the bottom.

15 Since the sensor is distanced from the bottom, the inspectability thereof is facilitated, as is the maintenance. Further, the fact of being distanced from the collection zone means that insignificant liquid
20 leakage can be ignored.

In the present embodiment, the liquid sensor is located in a vertically-distanced position from the bottom. More precisely, the sensor is located in a distanced
25 position which is vertically raised with respect to the liquid collection zone. For example, the sensor can be raised by 20-40 cm with respect to the bottom, or can operate in a measuring chamber located laterally with respect to the housing chamber.

30 The bottom can exhibit a non-horizontal shape: in this case the liquid collection zone (in reality numerous liquid collection zones might be included, distanced from one another and distributed around the bottom) is
35 located in a zone of maximum depth of the bottom, so

- 5 -

that the force of gravity forces any leaks coming from the hydraulic circuit to collect there. The collection zone or zones, then, are located on the bottom and receive and collect the liquid due to the position and
5 geometry of the bottom.

From a structural point of view, the bottom can comprise a wall which extends transversally of the lateral wall substantially at a base zone of the
10 support structure. The liquid sensor is located in a distanced position with respect to the upper surface of the wall, i.e. it is not in contact with the surface, but operates either externally of the housing chamber or, if located internally thereof, it operates in a
15 position which is detached from the bottom wall which collects and conveys the liquid towards the collection chamber.

Depending on the particular embodiment, the bottom wall
20 extends over the whole transversal section of the container body and exhibits a perimeter edge which is sealingly joined to the lateral wall thereof such that any substance which falls from the components contained in the container body can be collected on the bottom
25 wall. Alternatively the bottom wall can extend such as to exhibit a perimeter edge which develops in proximity of and adjacent to an internal surface of the lateral wall.

30 In an embodiment of the invention, at least one measuring chamber is afforded externally of the housing chamber and a channel which sets the liquid collection zone or zones in communication with the measuring chamber. If more than one collection zone is included
35 on the bottom, several channels could be included,

- 6 -

leading to a single measuring chamber or leading to
separate measuring chambers. Each channel exhibits a
first end, directly connected to a lower point of the
respective collection zone, and a second end, directly
5 connected to a lateral wall of the measuring chamber.
As for the nature of the liquid sensor operating in the
measuring chamber or chambers, it can be either a
liquid-presence sensor operating in the measuring
chamber, i.e. a sensor that is sensitive only to the
10 presence of liquid. This sensor is located at a height
which is vertically above the lowest point of the
collection zone and emits a measuring signal when the
liquid level in the measuring chamber is greater than
or equal to a predetermined level, for example when the
15 level exceeds the level in which the liquid-presence
sensor itself is operating. Alternatively a liquid
level sensor can be used, operating at the measuring
chamber and emitting a measuring signal which is
proportional to the liquid level in the measuring
20 chamber. In another aspect of the first embodiment, the
collection chamber can comprise an upper inspection
opening developing substantially horizontally and
externally of the lateral wall of the support structure
in order to enable direct access to the measuring
25 chamber and therefore to the sensor.

In a further embodiment the at least one liquid sensor
can comprise a member emitting a signal and a member
receiving the signal, the receiving member operating in
30 the housing chamber above and at a predetermined
distance from the bottom. In this case it is not
necessary that the liquid sensor enter into contact
with the liquid. For example, the emitting member can
operate internally of the housing chamber above and at
35 a predetermined distance from the bottom such as to

- 7 -

emit a signal crossing the collection zone (and thus any liquid accumulated in the collection zone) to be then reflected by the upper surface of the bottom towards the receiver member. The receiver member, according to the reflected signal received, can generate a measuring signal linked to the quantity of liquid present in the collection zone. It is specified that in an embodiment the emitter member can work at the bottom, for example at the collection zone. Further, the receiving member can be constituted by a single sensor member or by a plurality of members adequately distributed on the transversal section of the housing chamber. As for type, the emitting member can comprise a member selected from a group comprising: an emitter of an optic signal, an acoustic signal, an electric or electromagnetic signal. Similarly, the receiver can comprise a member selected from a group comprising: a receiver of an optic signal, an acoustic signal, an electric or electromagnetic signal.

In combination with one or more of the above-described characteristics, the medical apparatus can also comprise a user interface and a programmed control unit connected to the liquid sensor and the user interface. The control unit can for example comprise one or more digital microprocessor units or one or more analog type units, or combinations of analog units and digital units. In reference by way of example to a microprocessor unit, once the unit has performed a program (for example a program coming from the outside or directly integrated into the microprocessor card) the unit itself becomes programmed, so that a plurality of functional blocks are defined, which constitute means each designed to perform respective operations. In an aspect of the invention, the programmed control

- 8 -

unit defines means as specified herein below:

- means for receiving a measuring signal from the liquid sensor corresponding to a detection of the presence of liquid and/or liquid level;

5 and

- means for determining, depending on the measuring signal, occurrence or not of an alarm condition.

10 In a further aspect of the invention, the programmed control unit can define means for commanding the user interface to generate a corresponding acoustic and/or visible signal, should the existence of an alarm condition be detected.

15 In combination with one or more of the above-described characteristics, the medical apparatus can comprise at least one safety device operating in correspondence with at least the supply channel and commandable between at least one first operating condition, in
20 which the safety device enables a liquid flow along the supply channel towards the treatment zone, and a second operating condition, in which the safety device prevents passage of liquid towards the treatment zone. In this case, the control unit can be connected to the
25 safety device and programmed to define means for commanding the safety device to pass from the first to the second operating conditions, should an alarm condition be detected. In an embodiment, the safety device can for example comprise at least one intercept
30 member connected to the control unit; the intercept member in the first operating condition and on command of the control unit closing the fluid passage from said source along the supply channel.

35 The safety device can also comprise a bypass line

- 9 -

connecting the supply channel and the discharge channel, and one or more fluid check members connected to the control unit with the aim of selectively opening and closing the bypass channel and the supply channel
5 downstream of the bypass channel. On command of the control unit the check members of the first operating condition close the fluid passage towards the treatment zone and connect the source with the discharge channel through the bypass line.

10

Since the medical apparatus for blood treatment can comprise various liquid sources (for example one or more water sources, one or more concentrate sources, one or more liquid disinfectant sources) connected to
15 the supply channel with respective delivery lines, the medical apparatus can exhibit, at each delivery line, a respective check member (for example comprising a valve member or an occlusive pump).

20 In combination with one or more of the above-described characteristics, the medical apparatus can comprise electrical supply means (one or more power suppliers and the necessary electrical power components, in itself of known type) connectable to a source of
25 electric power, external to the apparatus and destined to supply electrical energy to the medical apparatus itself. In a further variant, the programmed control unit can be programmed for controlling means for cutting off the electrical supply (such as a switch
30 connected to the control unit) to the supply means on occurrence of said alarm condition.

In combination with one or more of the above-described characteristics, the support structure of the medical
35 apparatus can comprise:

- 10 -

- a predetermined number of internal walls which separate the housing chamber into the following sub-compartments:

- 5 • an upper chamber extending at the upper end of the housing chamber and housing the electronic circuitry inclusive of the control unit,
- 10 • a first intermediate chamber located at a vertically intermediate zone of the housing chamber, inferiorly with respect to the upper chamber, the first intermediate chamber housing the electrical supply devices,
- 15 • a second intermediate chamber located at a vertically intermediate zone of the housing chamber, inferiorly with respect to the upper chamber and adjacent to the first intermediate chamber, the second intermediate chamber housing one or more motor members and one or more actuators,
- 20 • a lower chamber, extending inferiorly of the intermediate chambers and above said bottom and housing the hydraulic circuit, the liquid sensor also being housed in the lower chamber.

When the sensor is operating in the lower chamber, the programmed control unit can include:

- 25 - means for receiving a measuring signal from the liquid sensor corresponding to a detection of the presence of liquid and/or the liquid level;
- 30 - means for calculating, depending on the measuring signal, the occurrence or not of an alarm condition, in which the means for determining the alarm condition reveal the existence of an alarm condition before a liquid level in the bottom reaches the liquid sensor.

In other words the sensor is vertically distanced from the collection zone and the programmed control unit is

35

- 11 -

such programmed that an alarm is set off before the liquid level reaches the sensor and therefore the sensor is protected from any possible immersion in the liquid.

5

Some preferred embodiments of the present invention will now be described with the aid of the accompanying figures of the drawings, provided purely by way of non-limiting example, and in which:

- 10 - figure 1 schematically illustrates the hydraulic circuit and the blood circuit of a medical apparatus for extracorporeal blood treatment;
- figure 2 schematically illustrates a section of a lower portion of a medical apparatus in an embodiment
15 of the present invention;
- figure 3 schematically illustrates a section of a lower portion of a medical apparatus in a further embodiment of the present invention;
- figure 4 schematically illustrates in side elevation
20 the support structure of an apparatus of the embodiments of figures 3 and 4;
- figure 5 is a side view of some details of the lower portion of the embodiment of figure 3;
- figure 6 is a perspective view of the bottom wall and
25 the measuring chamber of the embodiment of figures 3 and 5, and
- figures 7 and 8 are perspective views from different angles of the contents of figure 5;
- figures 9 and 10 are elevations from opposite sides
30 of the medical apparatus of the embodiment of figure 3, in which lateral closing panels have been removed to give a clearer picture of the internal components thereof;
- figure 11 is a front elevation of the apparatus of
35 figure 9.

- 12 -

With reference to the accompanying figures of the drawings, 100 denotes a medical apparatus for extracorporeal blood treatment, in an embodiment of the invention.

The apparatus 100 comprises a support structure 101 internally exhibiting a housing chamber 102 which includes at least one liquid collection zone 103. The support structure exhibits at least one lateral wall 104 substantially delimiting the housing chamber 102. In the illustrated example, the lateral wall extends in a vertical direction, superiorly joining a terminal portion of head 105, while inferiorly exhibiting a terminal portion of base 106, which cooperate with the lateral wall 104 to define a box structure in which various components of the apparatus for dialysis are housed. Different support structures from those described can be included: for example the terminal base portion is absent in some machines and the lateral wall, in that case, defines a housing chamber that is inferiorly open.

The support structure further comprises a bottom 107 arranged at a lower portion of the support structure. In particular, the bottom is located above the terminal base portion 106, if this is present, as in the illustrated embodiment. The bottom 107 comprises the liquid collection zone or zones 103 should these be more than one in number.

The apparatus further comprises a hydraulic circuit 1. An embodiment of the hydraulic circuit is for example schematically illustrated in figure 1. Note that the specific structure of the hydraulic circuit 1 is not

- 13 -

relevant for the purposes of the present invention and therefore other and different circuits to those specifically shown in figure 1 might be used in consequence of the functional and design needs of each
5 single medical apparatus.

The hydraulic circuit 1 exhibits at least one supply channel 2, destined to transport a treatment liquid from at least one source 3 towards a treatment station
10 4 where one or more blood treatment units 5 operate. The circuit 1 further comprises at least one discharge channel 6, destined for the transport of a used liquid from the treatment station 4 towards an evacuation zone, schematically denoted by 7 in figure 1.

15 The hydraulic circuit 1 is located in the housing chamber above the liquid collection zone 103, such that liquid leakage from the hydraulic circuit can at least partially accumulate at the liquid collection zone
20 itself; figures 3 and 4 show that as for location, the hydraulic circuit 1 (schematically represented by a rectangular frame in a broken line) can be housed in the lower chamber 139, which, as will be more fully described herein below, constitutes one of the parts
25 into which the housing chamber 102 is divided. The hydraulic circuit cooperates with a blood circuit 8, also schematically represented in figure 1 in its basis component parts. The specific structure of the blood circuit is also not fundamental, with reference to the
30 present invention. Thus, with reference to figure 1, a brief description of a possible embodiment of a blood circuit is made, which is however provided purely by way of non-limiting example.

35 The blood circuit 8 of figure 1 comprises an arterial

- 14 -

line 9 designed to remove blood from a vascular access
10 and a venous line 11 designed to return the treated
blood to the vascular access. The blood circuit of
figure 1 further comprises a first chamber, or blood
5 chamber, 12 of the blood treatment unit 5, the second
chamber 13 of which is connected to the hydraulic
circuit 1. In greater detail the arterial line is
connected at the inlet to the blood chamber 12, while
the venous line is connected at the output to the blood
10 chamber 12. In turn, the supply channel 2 is connected
at the inlet to the second chamber 13, while the
discharge channel is connected at the outlet to the
second chamber. The blood treatment unit 4, for example
a dialyzer or an ultrafilter or a plasma filter or a
15 hemofilter or a hemodiafilter, comprises, as mentioned,
the two chambers 12 and 13 which are separated by a
semipermeable membrane 14, for example of the hollow-
fibre type or plate type. The blood circuit can also
comprise one or more separators 15: in the example of
20 figure 1 a separator 15 is included at the venous line
11, upstream of a safety valve 16. The valve 16 can be
activated to close the venous line when, for example,
for security reasons the blood return to the vascular
access 10 has to be halted. The apparatus 100 can also
25 comprise one or more blood pumps 17, for example
positive displacement pumps such as peristaltic pumps;
in the example of figure 1, a pump 17 is included on
the arterial line 9.

30 As mentioned, the hydraulic circuit 1 is housed
internally of the chamber 102. In the illustrated
embodiment the blood circuit 8 is instead borne on a
front panel of the apparatus 100, which also supports
the peristaltic pump or pumps 17. The treatment unit 5
35 can be physically supported by the lateral wall 104,

- 15 -

and, in operating conditions of blood treatment, is connected both to the hydraulic circuit and to the blood circuit, as already illustrated (note that in figure 4 the blood circuit 8 and the unit 4 are represented with a broken line and schematically inasmuch as they are known).

A liquid sensor 108, destined at least to detect any liquid in the liquid collection zone 103, operates in a distanced position with respect to the collection zone itself. More precisely, when, as in the illustrated embodiment, the support structure comprises a bottom 107 arranged at a lower portion of the support structure and comprising the liquid collection zone 103, the liquid sensor is located at a distanced position and is thus not in contact with the bottom 107.

Since the sensor is distanced from the bottom, it is easier to inspect and maintain. Further, the fact of being distanced from the collection zone means that insignificant leakage of liquid can be ignored.

In an embodiment, should the sensor be operating internally of the housing chamber, it is located in a position which is distanced and vertically raised with respect to the liquid collection zone. For example, the sensor can be distanced by 20-40 cm from the bottom. Alternatively, the sensor can operate in a measuring chamber located laterally and externally with respect to the housing chamber.

In turn, the bottom 107 can exhibit a non-horizontal shape, as illustrated in the figures of the drawings in which the upper surface of the bottom converges in a

- 16 -

downwards direction at an axially central zone of the bottom; in this case the liquid collection zone (in reality numerous collection zones could be provided in reciprocally distanced positions, and distributed
5 throughout the bottom) is arranged in a zone of maximum depth of the bottom in order to receive, by free fall, any liquid leakage coming from the hydraulic circuit. In practice, the collection zone or zones are located on the bottom and receive and collect the liquid thanks
10 to the position and geometry thereof.

From a structural point of view, the bottom can comprise a wall 109 extending transversally of the lateral wall substantially at a base zone of the
15 support structure. The liquid sensor is located in a distanced position with respect to the upper surface of the wall, i.e. it is not in contact with the surface, but operates either externally of the housing chamber or internally of the housing chamber, in which case it
20 operates in a detached position from the bottom wall, which collects and conveys the liquid towards the collection chamber.

Depending on the embodiments, the bottom wall extends
25 over the whole transversal section of the container body and exhibits a perimeter edge 110 joined, for example sealingly, to the lateral wall 104, such that any substance falling from the components contained in the container body can be collected by the bottom wall.

30 Alternatively, the bottom wall can extend such as to exhibit a perimeter edge 110 developing in proximity of and adjacently to an internal surface of the lateral wall.

35

- 17 -

In a further embodiment of the invention (figures 3, 5-8), at least one measuring chamber 11 is arranged externally of the housing chamber 102 and a channel 112 which sets the liquid collection zone or zones in communication with the measuring chamber. Should more than one liquid collection zone be afforded on the bottom, several channels could be included, leading to a single measuring chamber or separate measuring chambers. Each channel 112 exhibits a first end, directly connected to a lower point 113a of the respective collection zone, and a second end 113b, directly connected at a lateral wall 114 of the measuring chamber 111. As for the nature of the liquid sensor operating in the measuring chamber or chambers, it can comprise a liquid-presence sensor operating in the measuring chamber: i.e. a sensor which is only sensitive to the presence of liquid; the sensor being located at a height which is vertically above the lowest point of the collection zone and emits a measuring signal when the liquid level in the measuring chamber is greater than or equal to a predetermined level, for example when the level exceeds the level at which the presence sensor operates. An alternative choice for a liquid sensor is a liquid level sensor operating in the measuring chamber and able to emit a measuring signal proportional to the liquid level present in the measuring chamber. In a further aspect of the first embodiment, the collection chamber can comprise an upper inspection opening 115 developing substantially horizontally and externally of the lateral wall 104 of the support structure in order to enable direct access to the measuring chamber and thus the sensor 108.

In an alternative (and with reference to figure 3), the

- 18 -

at least one liquid sensor 108 can comprise a member emitting a signal 116 and a receiver member 117 of the signal, the receiver member operating in the housing chamber above and at a predetermined distance from the
5 bottom. In this case it is not necessary for the liquid sensor to enter into contact with the liquid. For example, the emitter member can operate internally of the housing chamber above and at a predetermined distance from the bottom, such as to emit a signal
10 crossing the collection zone (and thus any liquid accumulated in the collection zone) to be then reflected from the upper surface of the bottom towards the receiver member. The receiver member, according to the reflected signal received, can generate a measuring
15 signal connected to the presence and/or the quantity of liquid present in the collection zone. It is specified that in an embodiment of the invention the emitter member can operate on the bottom, for example at the collection zone. Further, the emitter member and/or the
20 receiver member can be constituted by a single member or a plurality of members adequately distributed on the transversal section of the housing chamber. As for typologies, the emitter member can comprise a member selected from a group comprising: an optical, acoustic,
25 electric or electromagnetic signal emitter. Similarly, the receiver can comprise a member selected from a group comprising: a receiver of an optical, acoustic, electric or electromagnetic type.

30 The medical apparatus of any of the above-described embodiments can also comprise a user interface 118 and a programmed control unit 119 connected to the liquid sensor 108 and the user interface. The control unit 119 can for example comprise one or more digital
35 microprocessor units or one or more analog units or

- 19 -

other combinations of analog units and digital units. Relating by way of example to a microprocessor unit, once the unit has performed a special program (for example a program coming from outside or directly
5 integrated on the microprocessor card), the unit is programmed, defining a plurality of functional blocks which constitute means each designed to perform respective operations. In an aspect of the invention, the programmed control unit defines:

- 10 - means for receiving a measuring signal from the liquid sensor corresponding to detection of liquid presence and/or liquid level;
- means for determining, depending on the measuring signal, the occurrence or not of an alarm condition;
- 15 - means for commanding the user interface to generate a corresponding acoustic and/or visual signal, should an alarm condition be present.

In combination with one or more of the above
20 characteristics, the medical apparatus can comprise at least one safety device operating at least the supply channel and commandable between at least one first operating condition, in which the safety device allows a liquid flow along the supply channel towards the
25 treatment zone, and a second operative position, in which the safety device blocks passage of liquid towards the treatment zone. In this case, the control unit 119 can be connected to the safety device and programmed to define means for commanding the safety
30 device to pass from the first to the second operative condition, should an alarm condition have been detected. In an embodiment, the safety device can for example comprise at least one check member connected to the control unit: the check member in the first
35 operating condition and on command of the control unit

- 20 -

closes the fluid passage from the source along the supply channel. In figure 1 the safety device is a solenoid valve 120 controlled by the unit 119 as described above. Obviously a valve of another nature, either an occlusive pump or a further member able to selectively prevent and enable fluid passage can be used.

Alternatively or additionally to the valve 120, the safety device can also comprise a bypass line 121 which connects the supply channel and the discharge channel, and one or more fluid check members 122 connected to the control unit for selectively opening and closing the bypass channel and the supply channel downstream of the bypass channel. The components 121 and 122, which can be alternative or additional to the presence of the member 120 are represented by a broken line in figure 1.

The check members 122 in the first operative condition and on command of the control unit close the fluid passage towards the treatment zone and connect the source with the discharge channel through the bypass line. Again with the aim of controlling the fluid passage towards the unit 4, pumps 2a and 6a can be included, located respectively on the lines 2 and 6 and also connected to the control unit 119.

Since the medical apparatus for blood treatment can comprise various liquid sources (for example one or more water sources 3, one or more concentrate sources 123, 124, one or more sources of disinfectant liquids 125) connected to the supply channel 2 with respective delivery lines 126, 127 and 128, the medical apparatus can exhibit, at each delivery line, a respective check

- 21 -

member 129, 130, 131 (for example comprising a valve member and/or an occlusive pump).

In combination with one or more of the above-described
5 characteristics, the medical apparatus can comprise means for electrical supply (such as one or more sources, electrical filters and the necessary electric power components of known type and therefore not described in detail herein) connectable to an electric
10 supply source external to the apparatus and destined to distribute electrical energy coming from the outside at tensions, currents and frequencies which are correct for the medical apparatus. With reference to figure 1, the means for electric supply are schematically denoted
15 by the block 132 and can be connected to the outside source, represented schematically by the block 140, with the interposing of means for selectively enabling and interrupting the electrical connection represented by the block 133. In a further embodiment, the
20 programmed control unit 119 can be programmed to control means for selectively enabling and interrupting electrical energy 133 (such as for example a switch connected to the control unit) to the supply means on occurrence of the alarm condition.

25

Finally, again in combination with one or more of the above-described characteristics, the support structure of the medical apparatus can comprise: a predetermined number of internal walls 134 which separate the housing
30 chamber into the various sub-compartments:

- an upper chamber 135 located at the upper end of the housing chamber and housing the electronic circuitry 141, including the control unit 119,
- a first intermediate chamber 136 located at a
35 vertically intermediate zone of the housing chamber,

- 22 -

inferiorly with respect to the upper chamber 135, the first intermediate chamber housing the electrical source 132,

- 5 - a second intermediate chamber 137 located at a vertically intermediate zone of the housing chamber, inferiorly with respect to the upper chamber and adjacent to the first intermediate chamber, the second intermediate chamber housing one or more motors and one or more actuators, schematically denoted by the block 10 138 which can for example comprise the motors for the peristaltic pump or pumps 17 and the actuator for commanding the valve 16,
- a lower chamber 139, extending inferiorly of the intermediate chambers and above the bottom and housing 15 the hydraulic circuit 1, the liquid sensor being housed in the lower chamber.

If the sensor is operating in the lower chamber the programmed control unit can include:

- 20 - means for receiving a measuring signal from the liquid sensor corresponding to a detection of the presence of liquid and/or liquid level;
- means for determining, depending on the measuring signal, the occurrence or not of an alarm condition, in 25 which the means for determining the alarm condition verify the presence of an alarm condition before a liquid level in the bottom reaches the liquid sensor.

In other words the sensor is vertically distanced from 30 the collection zone and the programmed control unit is programmed such that the alarm signal is generated before the liquid level reaches the sensor which is thus protected from immersion in the liquid.

35 As already mentioned, the described embodiments are

- 23 -

intended to be non-limiting examples. In particular the circuits of figure 1 should not be interpreted as defining or limiting, as an apparatus such as in the invention can comprise other additional or alternative
5 components to those described.

For example an ultrafiltration line can be included, with at least one respective pump connected to the discharge line. One or more infusion lines can also be
10 included, with respective pumps or flow regulation valves, the infusion lines being connected up to the venous line 11 and/or the arterial line 9 and/or directly to the patient. The liquid sources can be pre-packaged bags and/or liquids prepared by the apparatus
15 itself.

Finally, one or more pumps 2a, 6a and all the necessary temperature, pressure and concentration sensors can operate either on the supply line or on the discharge
20 line, in order to adequately monitor the preparation and movement of the liquid in the hydraulic circuit.

- 24 -

C L A I M S

1. A medical apparatus (100) for extracorporeal blood treatment, comprising:
- 5 - a support structure (101) internally exhibiting a housing chamber (102), the housing chamber exhibiting at least one liquid collection zone (103),
- a hydraulic circuit (1) having at least one supply channel (2), destined to transport a treatment liquid
- 10 from at least one source (3) towards a treatment station (4), and at least one discharge channel (6), destined to transport a used liquid from the treatment station (4) towards an evacuation zone (7), the hydraulic circuit being located in the housing chamber
- 15 (102) above the liquid collection zone (103) such that liquid leakage from the hydraulic circuit system can at least partially accumulate in the liquid collection zone,
- a liquid sensor (108) destined at least to detect
- 20 presence of a liquid in the liquid collection zone, wherein the liquid sensor (108) operates in a distanced position with respect to the liquid collection zone (103).
- 25 2. The medical apparatus of claim 1, wherein the support structure exhibits at least one lateral wall (104) which substantially delimits the housing chamber and a bottom (107) arranged at a lower portion of the support structure and comprising at least the liquid
- 30 collection zone (103), the liquid sensor (108) being located in a distanced position from the bottom.
3. The medical apparatus of claim 2, wherein the bottom (107) exhibits a non-horizontal shape, the at least one
- 35 liquid collection zone being arranged in a maximum-

- 25 -

depth zone of the bottom in order to receive, by force of gravity, any liquid leakage coming from the hydraulic system.

- 5 4. The medical apparatus of claim 3, wherein the liquid sensor (108) is located at a distanced position which is vertically raised with respect to the liquid collection zone (103).
- 10 5. The medical apparatus of claim 4, wherein the bottom (108) comprises a wall (109) which extends transversally of the lateral wall, substantially at a base zone of the support structure, the liquid sensor being located at a distanced position from the upper surface of the
15 wall.
6. The medical apparatus of claim 5, wherein the bottom wall (109) exhibits a perimeter edge (110) which is sealingly jointed to the lateral wall (104).
20
7. The medical apparatus of claim 5, wherein the bottom wall (109) exhibits a perimeter edge (110) developing in proximity of and adjacent to an internal surface of the lateral wall.
25
8. The medical apparatus of any one of the preceding claims, comprising at least one measuring chamber (111) arranged externally of the housing chamber and a channel (112) which sets the at least one liquid
30 collection zone (103) in contact with the measuring chamber.
9. The medical apparatus of claim 8, wherein the liquid sensor (108) comprises a liquid-presence sensor
35 operating in the measuring chamber, the sensor being

- 26 -

located at a height which is vertically above the lowest point of the collection zone, the sensor emitting a measuring signal when the liquid level in the measuring chamber is greater than or equal to a level at which the presence sensor operates.

10. The medical apparatus of claim 8, wherein the liquid sensor (108) comprises a liquid level sensor operating at the measuring chamber and emitting a measuring signal which is proportional to a liquid level in the measuring chamber.

11. The medical apparatus of claim 8, wherein the channel (112) exhibits a first end (113a), directly connected to a lower point of the collection zone, and a second end (113b), directly connected to a lateral wall (114) of the measuring chamber.

12. The medical apparatus of any one of the preceding claims from 8 to 11, wherein the collection chamber comprises an upper opening (115) for inspection, which develops substantially horizontally externally of the lateral wall (104) of the support structure to enable direct access to the measuring chamber.

13. The medical apparatus of any one of claims from 1 to 7, wherein the at least one liquid sensor (108) comprises at least one emitter member (116) of a signal and at least one receiver member (117) of the signal, the receiver member operating in the housing chamber above and at a predetermined distance from the bottom.

14. The medical apparatus of claim 13, wherein the emitter member (116) also operates internally of the housing chamber above and at a predetermined distance

- 27 -

from the bottom, the emitter and the receiver being positioned and designed such that the emitter can emit a signal that crosses the collection zone and is reflected from the bottom towards the receiver member, the receiver member generating a measuring signal connected to a quantity of liquid present in the collection zone.

15. The medical apparatus of claim 14, wherein the emitter member comprises a member selected from a group comprising: an emitter producing an optical, an acoustic, an electrical or an electromagnetic signal.

16. The medical apparatus of claim 14, wherein the receiver member comprises a member selected from a group comprising: a receiver receiving an optical, an acoustic, an electrical or an electromagnetic signal.

17. The medical apparatus of any one of the preceding claims comprising at least one programmed control unit (119) connected to the liquid sensor (108), the programmed control unit including at least:

- means for receiving a measuring signal from the liquid sensor corresponding to a detecting of presence of liquid and/or a liquid level;
- means for determining, depending on the measuring signal, the occurrence or not of an alarm condition.

18. The medical apparatus of any one of the preceding claims, comprising: a user interface (118) operatively associated with a front portion of the lateral wall, the programmed control unit (119) being connected to the user interface and including means for commanding the user interface to generate a corresponding acoustic and/or visible signal when a presence of an alarm

- 28 -

condition is detected.

19. The medical apparatus of one of preceding claims 17
or 18, comprising at least one safety device (120; 121,
5 122) operating in at least the supply channel and
commandable between at least one operating condition,
in which the safety device enables a liquid flow along
the supply channel towards the treatment zone, and a
second operating condition, in which the safety device
10 prevents passage of liquid towards the treatment zone,
the control unit (119) being connected to the safety
device and programmed to define means for commanding
the safety device to pass from the first operating
condition to the second operating condition should an
15 alarm condition be detected.

20. The medical apparatus of claim 19, wherein the
safety device comprises at least one on-off member
(120) connected to the control unit, the on-off member,
20 in the first operating condition and on command of the
control unit, closing the fluid passage from the source
along the supply channel.

21. The medical apparatus of claim 19 or 20, wherein
25 the safety device comprises a bypass line (121) which
connects the supply channel and the discharge channel,
and one or more fluid on-off members (122) connected to
the control unit, the fluid on-off member or members
when in the first operating condition and on command of
30 the control unit closing the fluid passage towards the
treatment zone and connecting the source with the
discharge channel via the bypass line.

22. The medical apparatus of claim 19, wherein each
35 source (123, 124, 125) comprises a respective delivery

- 29 -

line (126, 127, 128) which sets a corresponding source in fluid communication with the supply channel (2), an on-off member (129,130, 131) comprising a valve member or an occlusive pump being included for each of the
5 delivery lines.

23. The medical apparatus of claim 17, comprising:
- electric supply means (132) connected to an electric source (140) external to the apparatus and destined to
10 distribute electrical energy to the medical apparatus,
- means for selectively enabling and interrupting electric supply to the supply means,
the programmed control unit (119) being programmed to control the means for selectively enabling and
15 interrupting (133) the electrical supply such as to disconnect the supply on detection of the alarm condition.

24. The medical apparatus of any one of the preceding
20 claims, wherein the support structure comprises:
- a predetermined number of internal walls which separate the housing chamber into sub-compartments as follows:
· an upper chamber (135) extending at the upper end of
25 the housing chamber and housing the electrical circuitry, including the control unit (119),
· a first intermediate chamber (136) located at a vertically intermediate zone of the housing chamber, inferiorly with respect to the upper chamber, the first
30 intermediate chamber housing means for electric supply (132),
· a second intermediate chamber (137) located at a vertically intermediate zone of the housing chamber, inferiorly with respect to the upper chamber and
35 adjacent to the first intermediate chamber, the second

- 30 -

intermediate chamber housing one or more motor members and one or more actuator members,
• a lower chamber (139), extending inferiorly of the intermediate chambers and superiorly of the bottom and
5 housing the hydraulic circuit.

25. The medical apparatus of claim 24, wherein the liquid sensor is housed in the lower chamber.

10 26. The medical apparatus of claim 25, comprising at least one programmed control unit (119) connected to the liquid sensor (108), the programmed control unit comprising at least:

- means for receiving a measuring signal from the
15 liquid sensor which means correspond to a liquid presence detection and/or a liquid level detection;
- means for determining, depending on the measuring signal, the occurrence or not of an alarm condition, the means for determining the alarm condition
20 determining the existence of an alarm condition before a liquid level in the bottom reaches the liquid sensor.

2/9

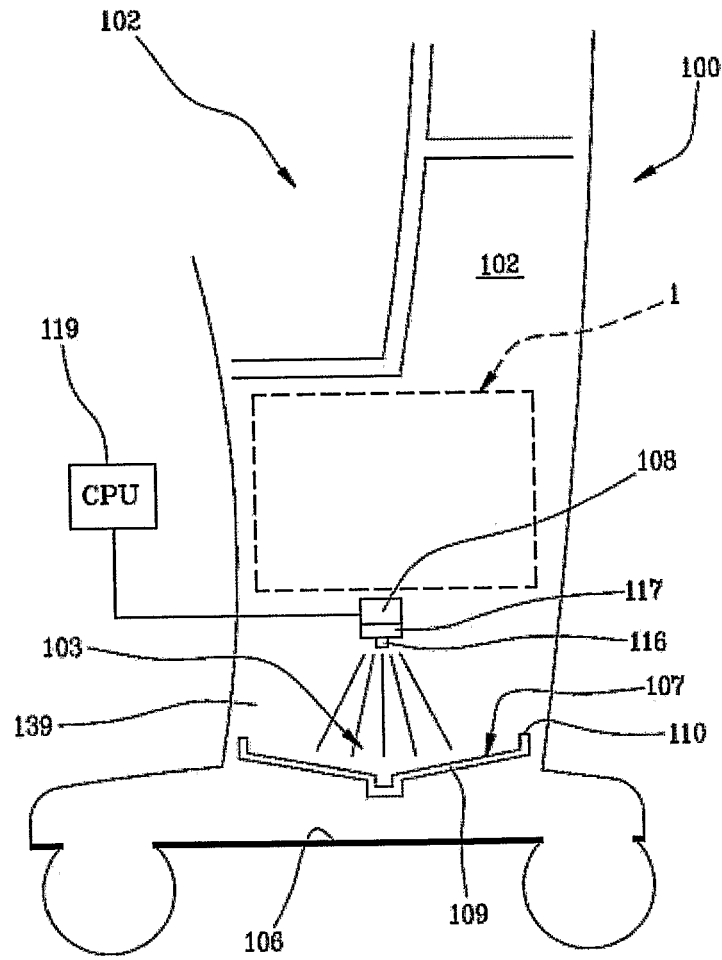

FIG 2

3/9

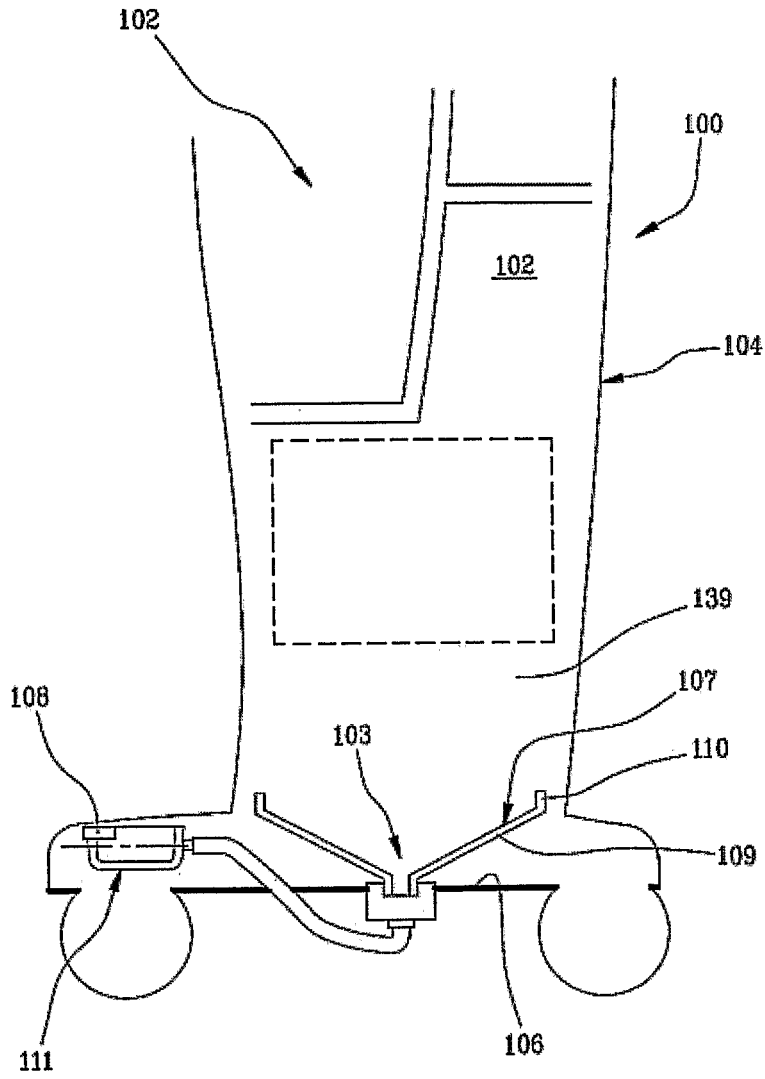

FIG 3

4/9

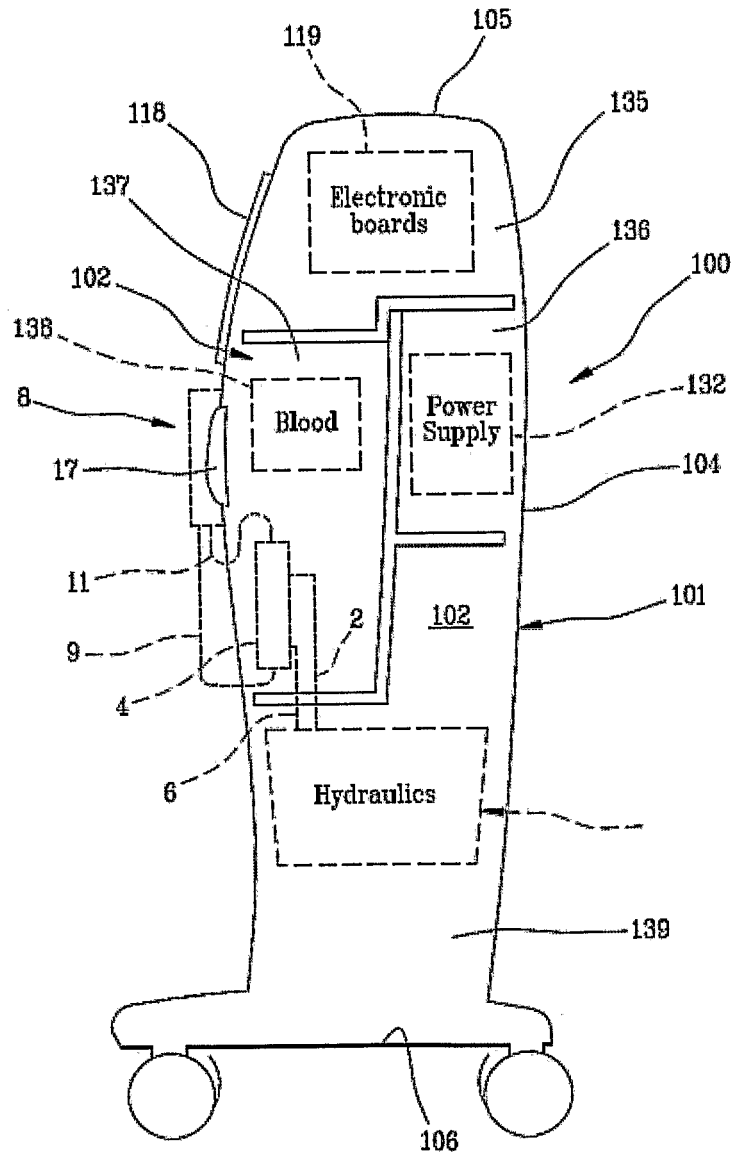

FIG 4

5/9

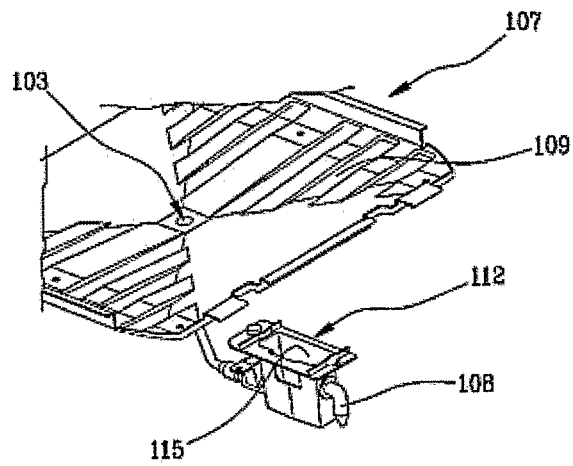

FIG 6

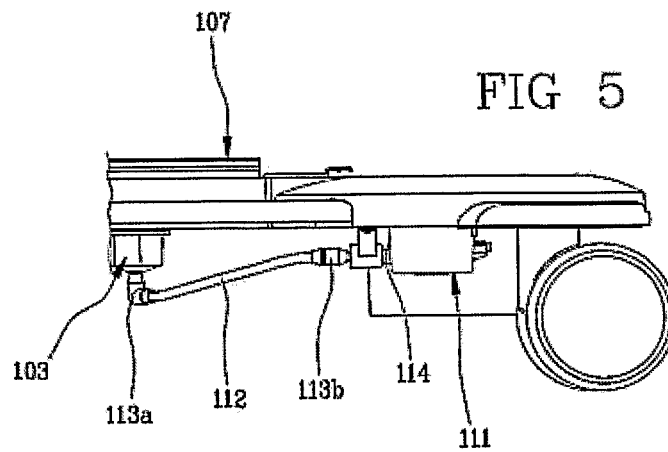

FIG 5

6/9

FIG 8

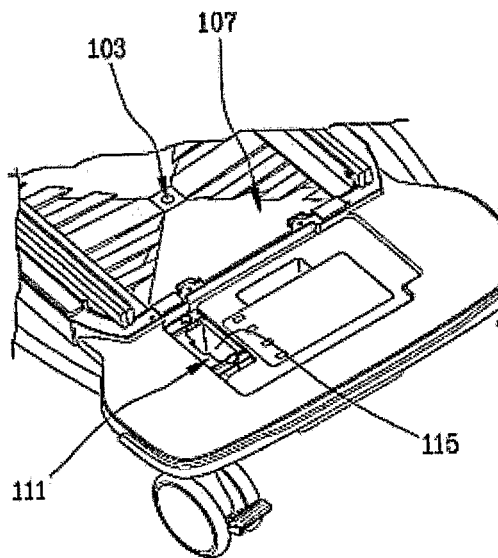
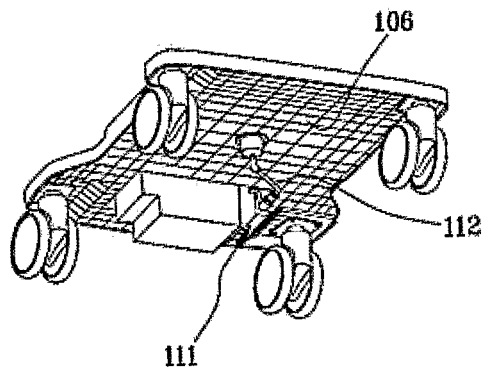
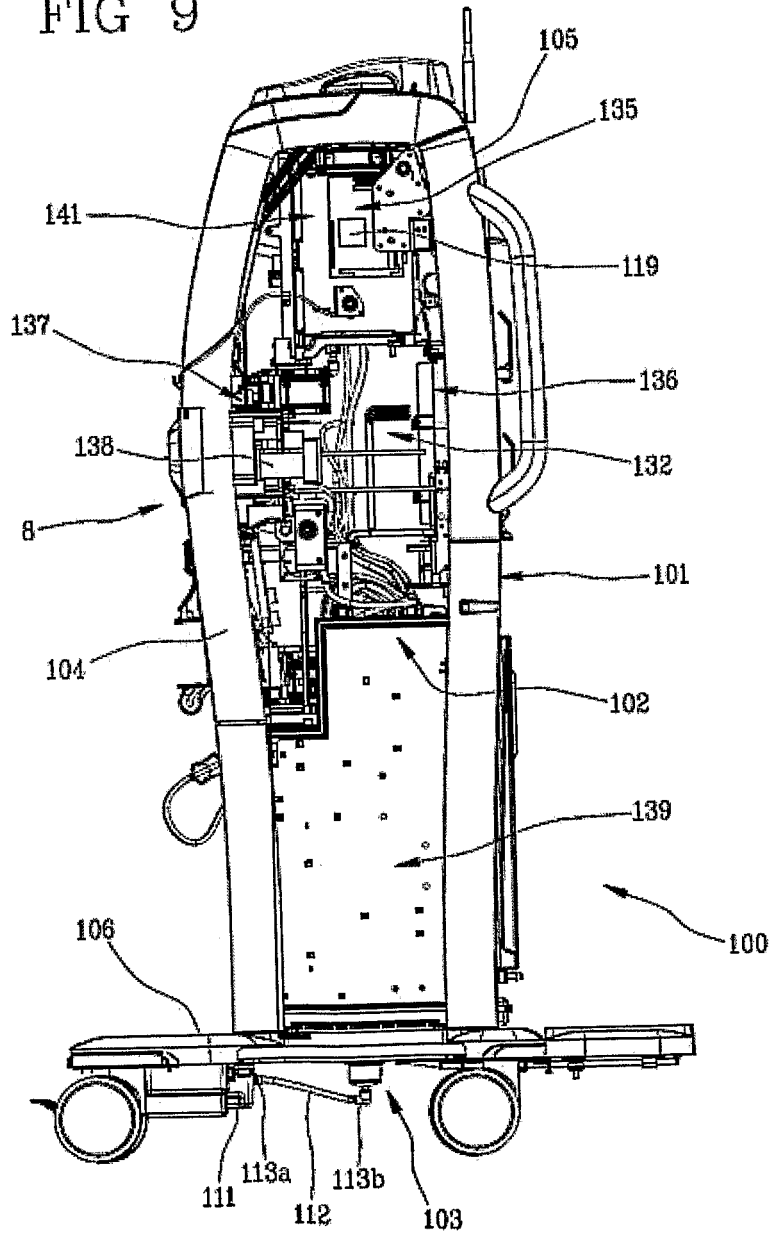

FIG 7

7/9

FIG 9



8/9

FIG 10

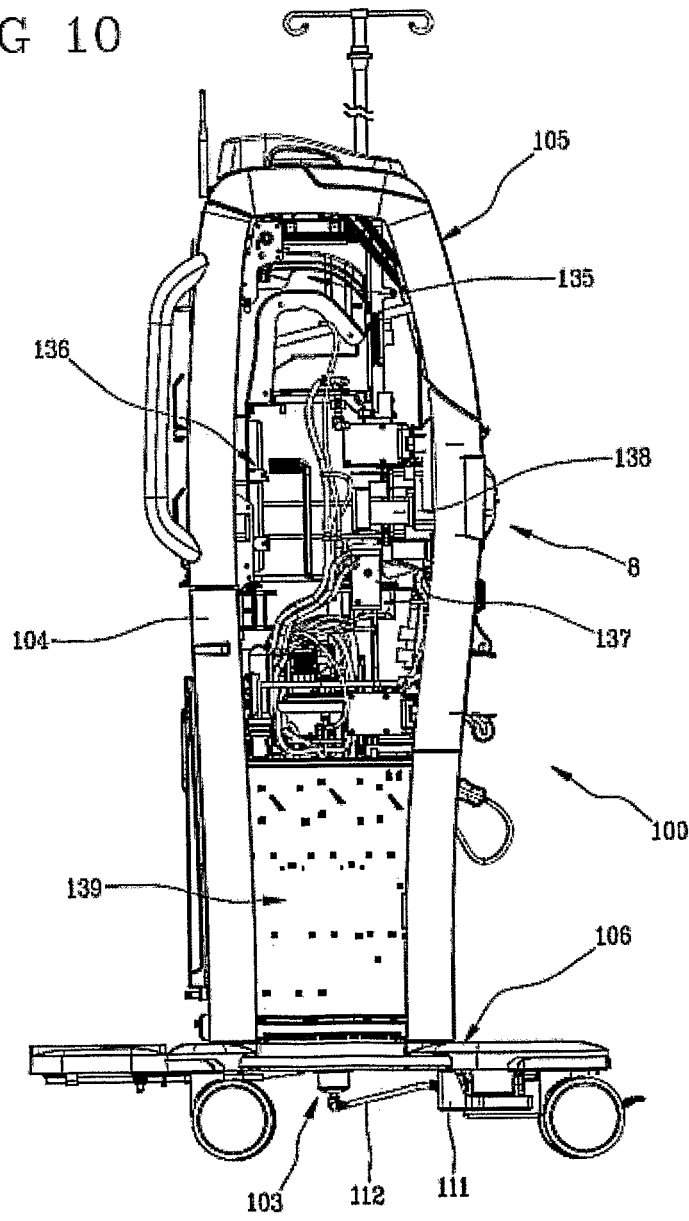

9/9

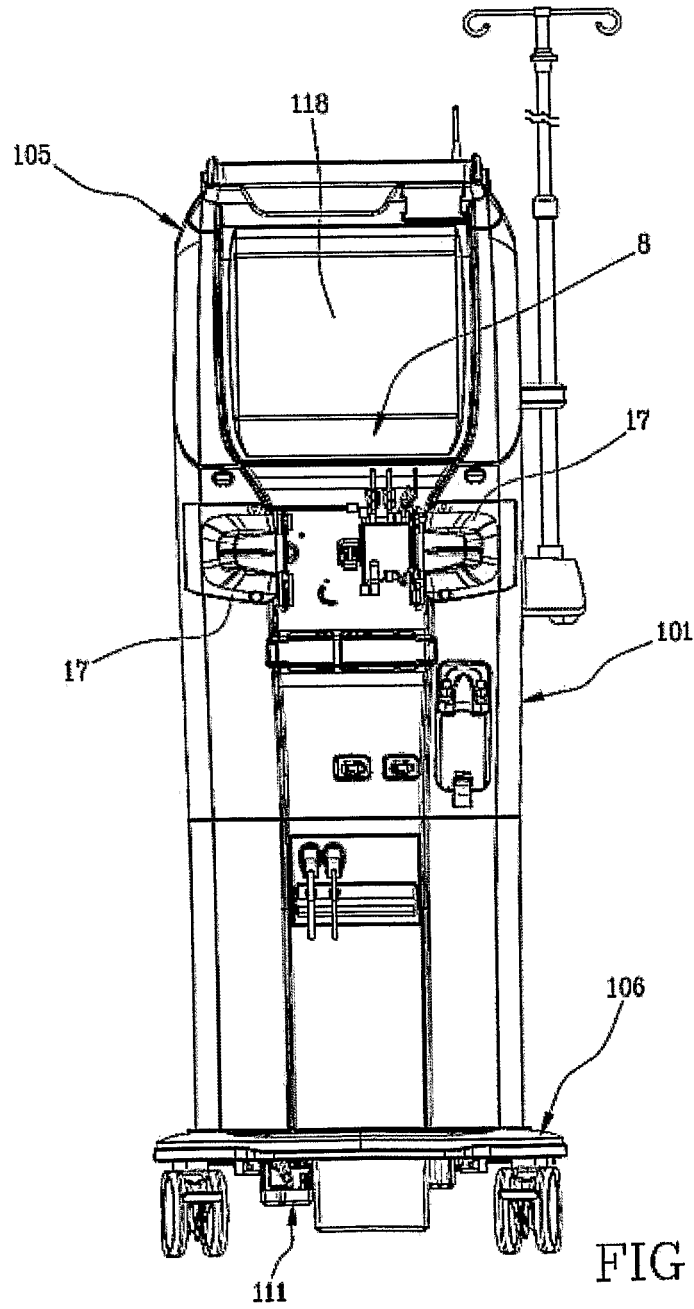

FIG 11

INTERNATIONAL SEARCH REPORT

International application No

PCT/IB2008/003504

A. CLASSIFICATION OF SUBJECT MATTER INV. A61M1/16 A61M1/34		
According to International Patent Classification (IPC) or to both national classification and IPC		
B. FIELDS SEARCHED		
Minimum documentation searched (classification system followed by classification symbols) A61M D06F G01M G01F B65D		
Documentation searched other than minimum documentation to the extent that such documents are included in the fields searched		
Electronic data base consulted during the international search (name of data base and, where practical, search terms used) EPO-Internal		
C. DOCUMENTS CONSIDERED TO BE RELEVANT		
Category*	Citation of document, with indication, where appropriate, of the relevant passages	Relevant to claim No.
Y	WO 2004/096322 A (TEIJIN PHARMA LTD [JP]; NAKAGAWA MAKOTO [JP]; IINO SHIGETOKI [JP]) 11 November 2004 (2004-11-11) cited in the application abstract figures 1-5	1-7, 13-20, 22-26
Y	DE 29 27 449 A1 (SIEMENS AG) 15 January 1981 (1981-01-15) the whole document	1-7, 13-20, 22-26
A	US 5 674 390 A (MATTHEWS DAWN [US] ET AL) 7 October 1997 (1997-10-07) column 33, line 61 - column 34, line 4 column 47, lines 42-57 figures 6,27	1
	-/--	
<input checked="" type="checkbox"/> Further documents are listed in the continuation of Box C. <input checked="" type="checkbox"/> See patent family annex.		
* Special categories of cited documents : *A* document defining the general state of the art which is not considered to be of particular relevance *E* earlier document but published on or after the international filing date *L* document which may throw doubts on priority claim(s) or which is cited to establish the publication date of another citation or other special reason (as specified) *O* document referring to an oral disclosure, use, exhibition or other means *P* document published prior to the international filing date but later than the priority date claimed *T* later document published after the international filing date or priority date and not in conflict with the application but cited to understand the principle or theory underlying the invention *X* document of particular relevance; the claimed invention cannot be considered novel or cannot be considered to involve an inventive step when the document is taken alone *Y* document of particular relevance; the claimed invention cannot be considered to involve an inventive step when the document is combined with one or more other such documents, such combination being obvious to a person skilled in the art. *&* document member of the same patent family		
Date of the actual completion of the international search 16 April 2009		Date of mailing of the international search report 24/04/2009
Name and mailing address of the ISA/ European Patent Office, P.B. 5818 Patentlaan 2 NL - 2280 HV Rijswijk Tel. (+31-70) 340-2040, Fax: (+31-70) 340-3016		Authorized officer Bichlmayer, K

INTERNATIONAL SEARCH REPORT

International application No
PCT/IB2008/003504

C(Continuation). DOCUMENTS CONSIDERED TO BE RELEVANT

Category*	Citation of document, with indication, where appropriate, of the relevant passages	Relevant to claim No.
A	DE 195 16 789 A1 (STOECKERT INSTR GMBH [DE] SORIN GROUP DEUTSCHLAND GMBH [DE]) 14 November 1996 (1996-11-14) abstract -----	15
A	US 5 697 248 A (BROWN RICHARD HUNTER [GB]) 16 December 1997 (1997-12-16) abstract -----	15

INTERNATIONAL SEARCH REPORT

Information on patent family members

International application No

PCT/IB2008/003504

Patent document cited in search report	Publication date	Patent family member(s)	Publication date
WO 2004096322 A	11-11-2004	JP 2004329265 A	25-11-2004
DE 2927449 A1	15-01-1981	NONE	
US 5674390 A	07-10-1997	AU 698545 B2	29-10-1998
		AU 4444996 A	22-08-1996
		AU 4977996 A	04-09-1996
		CA 2168629 A1	14-08-1996
		DE 19605260 A1	28-11-1996
		DE 19655223 B4	06-03-2008
		DE 19655224 B4	16-11-2006
		DE 19655225 B4	06-03-2008
		DE 19655226 B4	15-01-2009
		DE 19655228 B4	18-09-2008
		DE 19655230 B4	02-04-2009
		GB 2299026 A	25-09-1996
		JP 9000618 A	07-01-1997
		JP 2002503115 T	29-01-2002
		JP 3834552 B2	18-10-2006
		JP 2003235961 A	26-08-2003
		JP 3802493 B2	26-07-2006
		JP 2003199821 A	15-07-2003
		JP 2003245344 A	02-09-2003
		JP 3802494 B2	26-07-2006
		JP 2003235966 A	26-08-2003
		JP 3802495 B2	26-07-2006
		JP 2003235965 A	26-08-2003
		JP 3802496 B2	26-07-2006
		JP 2003235963 A	26-08-2003
		JP 3834553 B2	18-10-2006
		JP 2004000479 A	08-01-2004
		JP 3802497 B2	26-07-2006
		JP 2003199819 A	15-07-2003
		WO 9625214 A1	22-08-1996
		US 5591344 A	07-01-1997
		US 5674404 A	07-10-1997
		US 5705066 A	06-01-1998
		US 5645734 A	08-07-1997
		US 5690831 A	25-11-1997
		US 5658456 A	19-08-1997
		US 5707086 A	13-01-1998
		US 5674397 A	07-10-1997
		US 5630935 A	20-05-1997
		US 5690821 A	25-11-1997
		US 5725776 A	10-03-1998
		US 5670050 A	23-09-1997
		US 5702606 A	30-12-1997
		US 5651893 A	29-07-1997
		US 5788099 A	04-08-1998
		US 5714060 A	03-02-1998
		US 5932110 A	03-08-1999
DE 19516789 A1	14-11-1996	NONE	
US 5697248 A	16-12-1997	AU 2369192 A	23-02-1993
		DE 69217994 D1	10-04-1997
		DE 69217994 T2	04-09-1997
		EP 0621944 A1	02-11-1994

INTERNATIONAL SEARCH REPORT

Information on patent family members

International application No
PCT/IB2008/003504

Patent document cited in search report	Publication date	Patent family member(s)	Publication date
US 5697248	A	WO 9302340 A1 JP 7502339 T	04-02-1993 09-03-1995
<hr/>			