

(19) World Intellectual Property Organization
International Bureau



(43) International Publication Date
8 February 2007 (08.02.2007)

PCT

(10) International Publication Number
WO 2007/016021 A3

(51) International Patent Classification:
F16L 17/06 (2006.01)

(21) International Application Number:
PCT/US2006/028609

(22) International Filing Date: 24 July 2006 (24.07.2006)

(25) Filing Language: English

(26) Publication Language: English

(30) Priority Data:
11/191,888 28 July 2005 (28.07.2005) US

(71) Applicant and

(72) Inventor: **PUTCH, Samuel, W.** [US/US]; 5727 Portal Drive, Houston, TX 77096 (US).

(74) Agent: **HELMREICH, Loren, G.;** BROWNING BUSHMAN, P.C., 5718 Westheimer, Suite 1800, Houston, TX 77057 (US).

(81) Designated States (unless otherwise indicated, for every kind of national protection available): AE, AG, AL, AM, AT, AU, AZ, BA, BB, BG, BR, BW, BY, BZ, CA, CH, CN, CO, CR, CU, CZ, DE, DK, DM, DZ, EC, EE, EG, ES, FI, GB, GD, GE, GH, GM, HN, HR, HU, ID, IL, IN, IS, JP,

KE, KG, KM, KN, KP, KR, KZ, LA, LC, LK, LR, LS, LT, LU, LV, LY, MA, MD, MG, MK, MN, MW, MX, MZ, NA, NG, NI, NO, NZ, OM, PG, PH, PL, PT, RO, RS, RU, SC, SD, SE, SG, SK, SL, SM, SY, TJ, TM, TN, TR, TT, TZ, UA, UG, US, UZ, VC, VN, ZA, ZM, ZW.

(84) Designated States (unless otherwise indicated, for every kind of regional protection available): ARIPO (BW, GH, GM, KE, LS, MW, MZ, NA, SD, SL, SZ, TZ, UG, ZM, ZW), Eurasian (AM, AZ, BY, KG, KZ, MD, RU, TJ, TM), European (AT, BE, BG, CH, CY, CZ, DE, DK, EE, ES, FI, FR, GB, GR, HU, IE, IS, IT, LT, LU, LV, MC, NL, PL, PT, RO, SE, SI, SK, TR), OAPI (BF, BJ, CF, CG, CI, CM, GA, GN, GQ, GW, ML, MR, NE, SN, TD, TG).

Published:
— with international search report
— with amended claims

(88) Date of publication of the international search report:
20 September 2007

Date of publication of the amended claims:
22 November 2007

For two-letter codes and other abbreviations, refer to the "Guidance Notes on Codes and Abbreviations" appearing at the beginning of each regular issue of the PCT Gazette.

(54) Title: SEAL RING AND METHOD

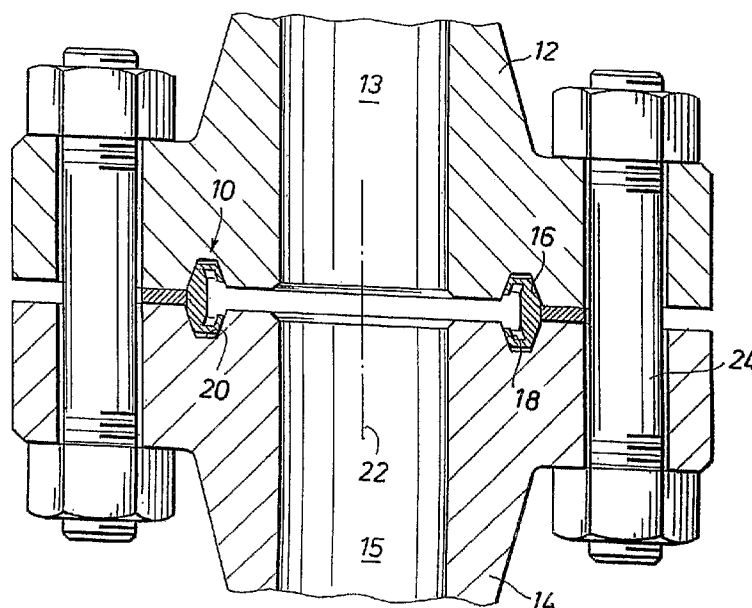

(57) Abstract: A seal ring (10) for sealing between first and second members (12, 14) each having an outer groove surface (16, 126) and inner groove surface (18, 127) includes a metal seal body (26, 42, 52, 60, 70, 80, 92, 110, 122, 140) for engagement with the outer groove surface on the first and second members, and a metal flexible flange (30, 32, 44, 46, 54, 56, 62, 64, 76, 78, 88, 90, 94, 96, 112, 114, 128, 144, 146) with a cantilevered end of a flexible flange providing substantially line contact sealing engagement with the inner groove surface on respective first and second member. The metal flexible flange is configured for being fluid pressure energized, and is deformed beyond its elastic limit when securing members secure the first member to the second member.

WO 2007/016021 A3

AMENDED CLAIMS

received by the International Bureau on 27 September 2007 (27.09.2007)

1. A seal ring for sealing between first and second members each having a through bore, a radially outer circumferential groove surface inclined outwardly in a direction toward the seal ring, and a radially inner circumferential groove surface inclined inwardly in a direction toward the seal ring, and securing members arranged circumferentially about the first and second members to secure the first member to the second member, the sealing ring comprising:

a metal seal body for engagement with each of the outer groove surfaces on the first and second members when the securing members secure the first member to the second member, the metal seal body being flexed inward when the securing members are moved to secure the first member to the second member; and

a metal flexible flange radially inward at the seal body such that a cantilevered end of the flexible flange provides substantially line contact sealing engagement with the inner groove surface on a respective first and second member, a spacing between the flexible flange and the seal body providing for fluid pressure energization of the flexible flange, and the flexible flange flexed outwardly and being deformed beyond its elastic range when the securing members secure the first member to the second member.

2. A seal ring as defined in Claim 1, wherein the seal body and the flexible flange are formed from a unitary homogenous material.

3. A seal ring as defined in Claim 1, wherein the seal body has substantially line contact sealing engagement with the outer groove surface on a respective first and second member.

4. A seal ring as defined in Claim 1, further comprising:
an annular flange extending radially outward from the seal body for planar engagement with planar flange engaging faces on the first and second members.

5. A seal ring is defined in Claim 4, wherein the annular flange is supported on the seal body.

6. A seal ring as defined in Claim 4, wherein the annular flange and the seal body are formed from a unitary homogeneous material.

7. A sealing ring as defined in Claim 1, wherein the seal body and another flexible flange forms a substantially C-shaped cross sectional configuration.

9. A seal ring as defined in Claim 1, wherein the flexible flange is fixedly secured to the seal body.

11. A seal ring as defined in Claim 1, wherein the outer groove surface is a tapered surface directed radially inward in a direction away from an interface

of the first and second members, and the inner groove surface is a tapered surface directed radially outward in a direction away from the interface of the first and second members.

12. A seal ring as defined in Claim 1, further comprising:

another flexible flange for substantially line contact sealing engagement with the other of the first and second members.

13. A seal ring for sealing between first and second members each having a through bore, a radially outer circumferential groove surface inclined outwardly in a direction toward the seal ring, a radially inner circumferential groove surface, and a circumferential base surface between a respective outer groove surface and inner groove surface inclined inwardly in a direction toward the seal ring, and securing members arranged circumferentially about the first and second members to secure the first member to the second member, the seal ring comprising:

a metal seal body for engagement with each of the outer groove surface on the first and second members when the securing members secure the first member to the second member, the metal seal body being flexed inward when the securing members are moved to secure the first member to the second member; and

a metal flexible flange supported on to the seal body and extending radially inward such that a cantilevered end of a flexible flange provides

substantially line contact engagement with one of the base surface and the inward groove surface on a respective first and second member, the flexible flange flexed outwardly and being deformed beyond its elastic limit when the securing members secure the first member to the second member, and a spacing between the flexible flange and seal body providing for fluid pressure energization of the flexible flange.

14. A seal ring as defined in Claim 13, wherein the seal body has substantially line contact sealing engagement with the outer groove surface on a respective first and second member.

15. A seal ring as defined in Claim 13, wherein the cantilever end of the flexible flange is in sealing engagement with the base of a respective first and second member when the securing members secure the first member to the second member.

16. A seal ring as defined in Claim 13, wherein the cantilevered end of the flexible flange is in sealing engagement with the inner groove surface of a respective first and second member when the securing members secure the first member to the second member.

17. A seal ring as defined in Claim 13, further comprising:

another flexible flange for substantially line contact sealing engagement with the other of the first and second members.

18. A seal ring as defined in Claim 13, wherein the outer groove surface is a tapered surface directed radially inward in a direction away from an interface at the first and second members, and the inner groove surface is a tapered surface directed radially outward in a direction away from the interface of the first and second members.

21. A seal ring for sealing between first and second members each having a through bore in fluid communication with the throughbore in the other member, each member having a circumferential mating surface extending radially outward from the respective throughbore and a circumferential groove in the mating surface open to the circumferential groove in the other member and having a radially outer circumferential groove surface inclined outwardly in a direction toward the seal ring, a radially inner circumferential groove surface inclined inwardly in a direction toward the seal ring, and a circumferential base surface between a respective outer groove surface and inner groove surface, the outer groove surface being a tapered surface directed radially inward in a direction away from an interface of the first and second members, and the inner groove surface being a tapered surface directed radially outward in a direction away from the interface of the first and second members, and securing members

arranged circumferentially about the first and second members to secure the first member to the second member, the seal ring comprising:

a metal seal body for engagement with each of the outer groove surface on the first and second members when the securing members secure the first member to the second member, the metal seal body being flexed inward when the securing members are moved to secure the first member to the second member;

a pair of metal flexible flanges supported on to the seal body and each extending radially inward such that a cantilevered end of a flexible flange provides substantially line contact engagement with one of the base surface and the inward groove surface on a respective first and second member;

the seal body and the pair of metal flexible flange having a substantially C-shaped cross-sectional configuration; and

each flexible flange being deformed beyond its elastic limit when the securing members secure the first member to the second member, and a spacing between the flexible flange and seal body providing for fluid pressure energization of the flexible flange.

22. A seal ring as defined in Claim 21, wherein a radially outer portion of the seal body is thicker than a thickness of either of the pair of metal flexible flanges.

23. A seal ring as defined in Claim 21, wherein each of the pair of metal flexible flanges extends axially toward each other.

24. A seal ring as defined in Claim 21, wherein the cantilevered end of each flexible flange is in sealing engagement with the inner groove surface of a respective first and second member when the securing members secure the first member to the second member.