

A. LKIEVICZ.
DREDGE CUTTER.

APPLICATION FILED MAR. 14, 1908.

Patented Nov. 10, 1908.

3 SHEETS—SHEET 1.

903,210.

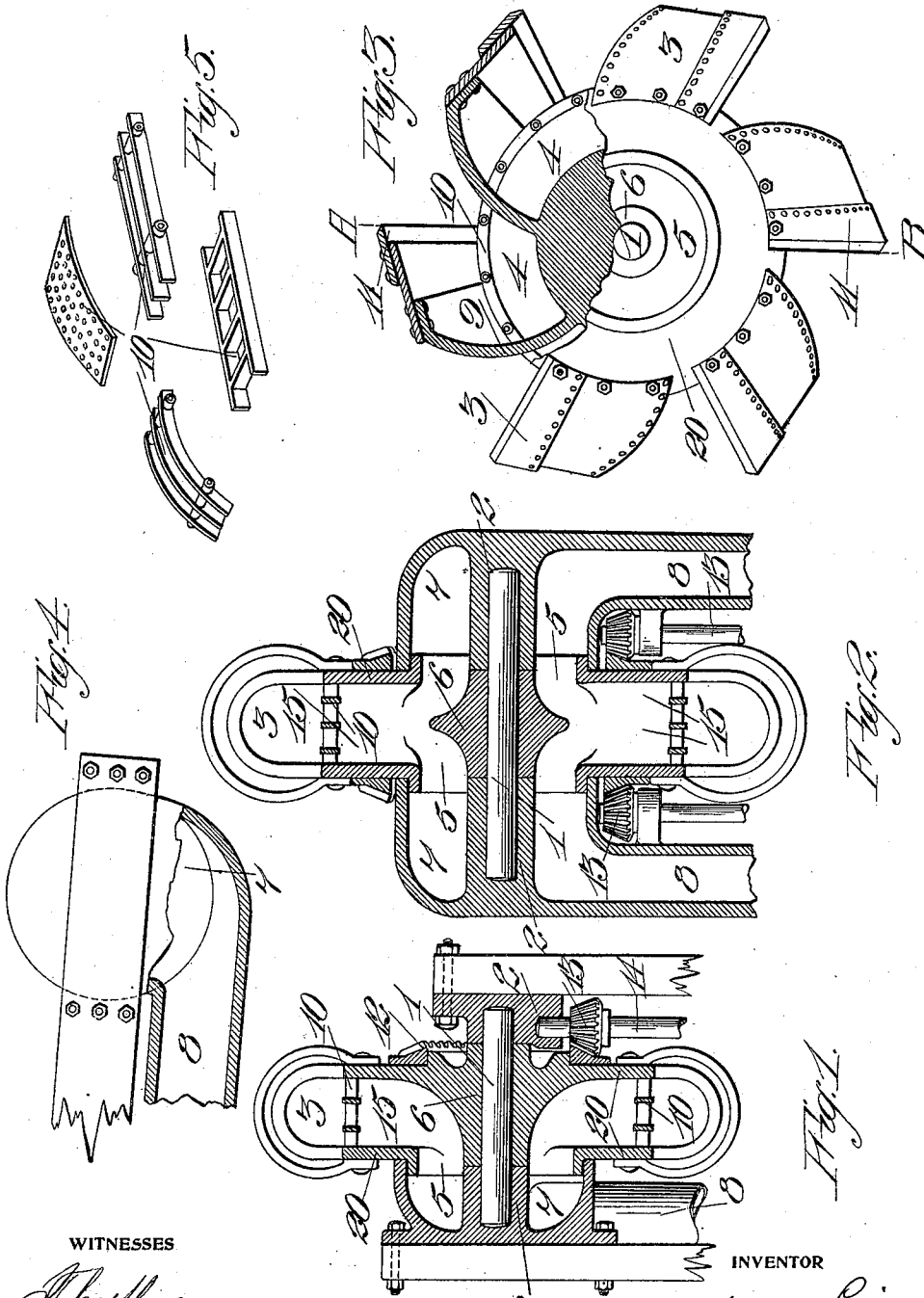

WITNESSES

A. Hartberg.
Charles Knifield

INVENTOR

BY *Alfonso Lkiewicz*
Geo. H. Strong.
ATTORNEY

A. LKIEVICZ.
DREDGER CUTTER.

APPLICATION FILED MAR. 14, 1908.

903,210.

Patented Nov. 10, 1908.

3 SHEETS—SHEET 2.

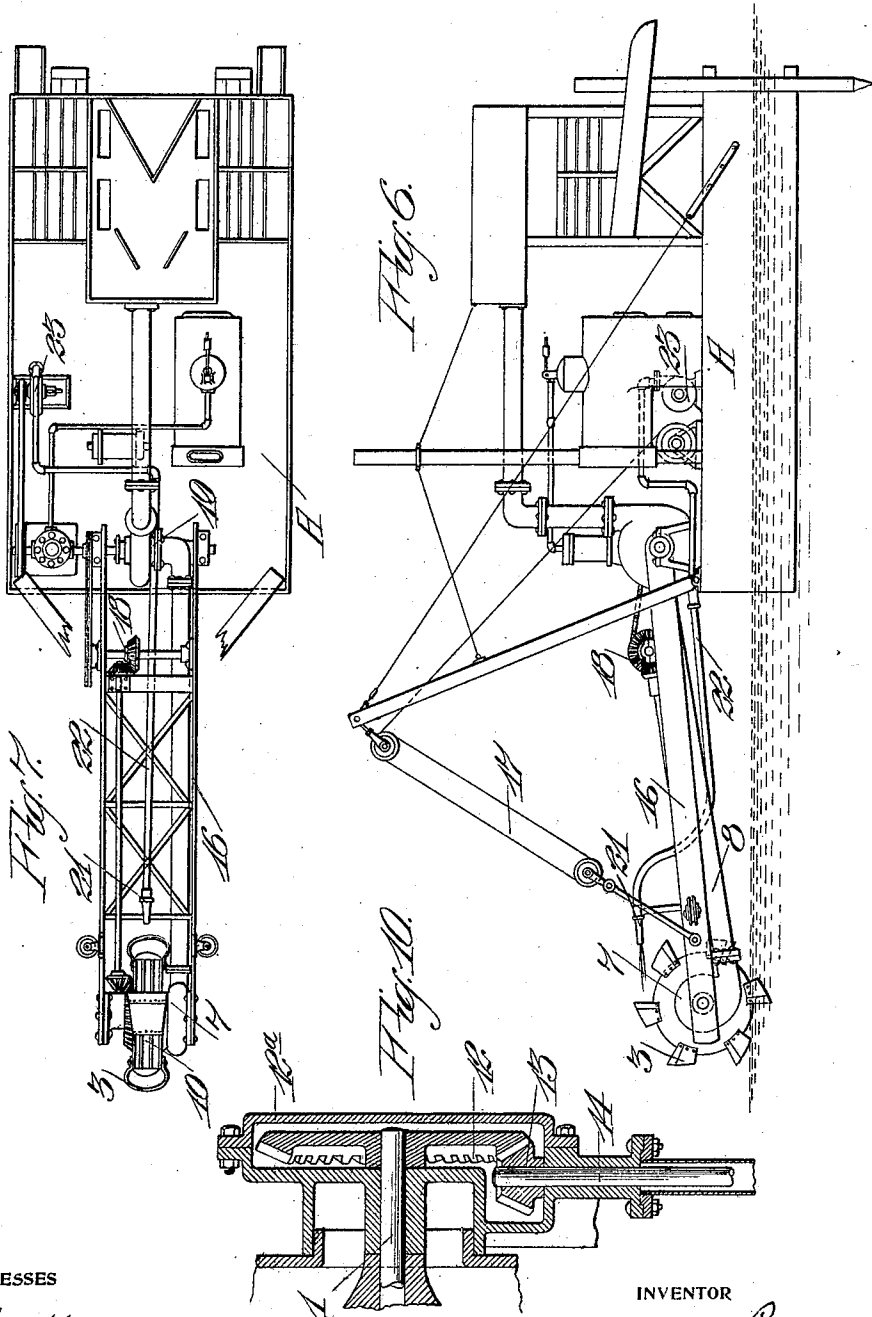

WITNESSES

E. Gustberg
Charles A. Field

INVENTOR

BY *Alfonso Lkiewicz*
Geo. H. Strong
ATTORNEY

A. LKIEVICZ.
DREDGER CUTTER.

APPLICATION FILED MAR. 14, 1908.

Patented Nov. 10, 1908.
3 SHEETS—SHEET 3.

903,210.

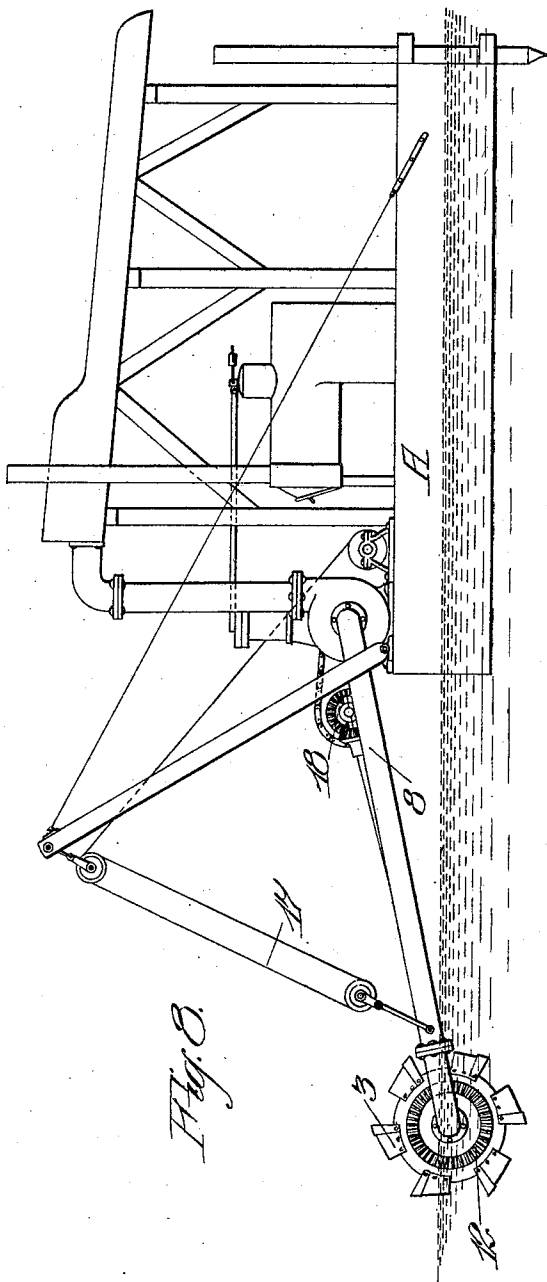

Fig. 8.

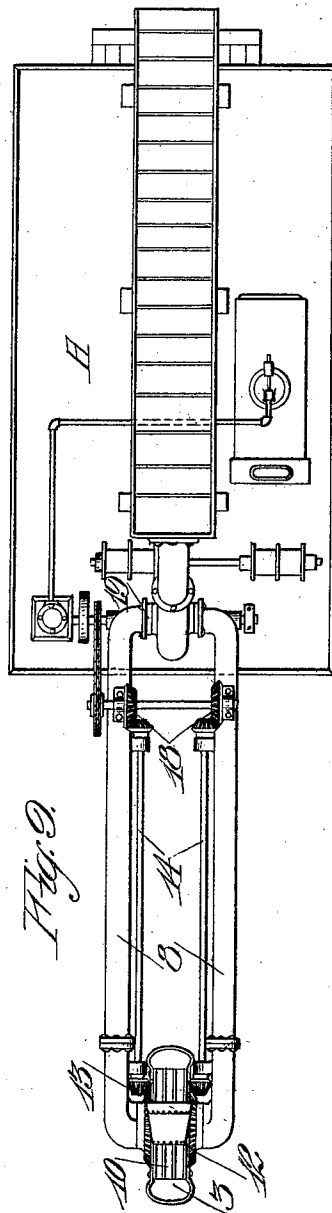

Fig. 9.

WITNESSES

J. Kashberg
Charles A. Field

INVENTOR

BY *Alfonso Lkiewicz*
Geo. H. Strong
ATTORNEY

UNITED STATES PATENT OFFICE.

ALFONSO LKIEVICZ, OF BERKELEY, CALIFORNIA.

DREDGER-CUTTER.

No. 903,210.

Specification of Letters Patent.

Patented Nov. 10, 1908.

Application filed March 14, 1908. Serial No. 421,092.

To all whom it may concern:

Be it known that I, ALFONSO LKIEVICZ, citizen of United States, residing at Berkeley, in the county of Alameda and State of California, have invented new and useful Improvements in Dredger-Cutters, of which the following is a specification.

My invention relates to dredging and digging apparatus. It is especially applicable to the dredging of gravel and material from the beds of water-courses for the purpose of saving any valuable or precious metals which may be associated therewith, and it can also be used for ordinary dredging purposes where earth or material is to be removed.

It consists of the combination of parts and details of construction which will be more fully explained by reference to the accompanying drawings, in which—

Figure 1 is a cross section taken through A—B, Fig. 3, of a single outlet cutter wheel. Fig. 2 is a cross section of a double outlet cutter wheel. Fig. 3 is a side view partly in section of a cutter wheel. Fig. 4 is a side view partly in section of a suction chamber. Fig. 5 shows various forms of screen bars. Fig. 6 is a side view of a single outlet cutter wheel in combination with a single suction dredging pump. Fig. 7 is a plan view of Fig. 6. Fig. 8 is a side view of a double outlet cutter wheel in combination with a double suction dredging pump. Fig. 9 is a plan view of Fig. 8. Fig. 10 is a section showing inclosed gears.

As shown in the drawings, A is a float. Hinged or otherwise connected to the float is a ladder 16, the front end of which may be suspended by cable or rope 17, and said ladder may be raised or lowered by means of suitable winding drums at will of operator. At the end of said ladder is a cutter-wheel, connected through suitable gears or gearing to a motor. Upon the front of this ladder is journaled the cutter-wheel. This wheel has its shaft 1 turnable in bearings 2 and is revolved by means of gears as at 12, and pinions 13, mounted upon a shaft 14, which is journaled upon the ladder, and extends rearwardly, where by means of suitable gearing as at 18, power may be transmitted from suitable prime motor to rotate said cutter-wheel at any desired rate of speed. Upon the periphery of said cutter wheel are located one or more digging buckets 3. These buckets 3 have a suitable scoop-shaped form and are adapted to excavate the material

from beneath and toward the front, as the buckets are brought in contact with material.

The digging buckets 3 are open on the side facing toward the center of the wheel, and these openings 15 coincide with passage-ways 4 leading to the side outlet 5 of the cutter wheel. These passage-ways 4 are formed of side walls 20, and radially curved or straight ribs 9 extending from periphery of the cutter wheel to or near the hub 6. This hub 6 is of such length upon the axle as to substantially fit between or against the journal-boxes 2, and its periphery extends radially outward converging to a thin edge, as in Fig. 2, so that the side or sides of the hub form the opposite side or sides of the discharge passage or passages, which lead into the suction chamber 7. Placed in these passage-ways 4 are screen bars 10, or perforated plates, extending entirely or part way around the circumference of the wheel, as illustrated in Figs. 1, 2 and 3.

By this construction it is seen that as the buckets 3 pass around the lower part of their travel, they are filled with material, and as the revolution is continued, the finer material is delivered by gravity between the screen bars 10 through the openings on the periphery of wheel to the passage-ways 4, and thence discharged through said passage-ways into the suction chamber 7, through side outlet 5 of cutter wheel. The coarse material, such as large sized rocks and debris, is retained in the buckets and as the cutter wheel continues its revolution, is discharged by gravity behind the wheel.

It is thus apparent that gold or other precious metal when once picked up in digging buckets, cannot escape being delivered to the suction chamber 7 by way of passages 4 and side outlet 5 of the cutter wheel, thence through the suction pipe 8 to the dredging pump, hydraulic elevator or similar elevating device.

The suction pipe 8 extends along the ladder and has a packed swivel joint 19 at the pump so that as the ladder is raised or depressed, the swivel joint 19 remains in an air-tight condition, while it allows the cutter wheel to follow the digging cut. The ladder is also fitted with a hydraulic nozzle 21 supplied with water through pipe 22 which receives its water under pressure from pump 23; the object being to materially assist in discharging the buckets. This nozzle is so fixed with relation to the buckets that it

discharges a jet of water into the buckets, preferably as they approach the nozzle in a loaded condition, and when the contents of the buckets are of a clayey or adherent character the jet or jets will disintegrate the mass so that the finer portions will pass through the screens to the central discharge, and any stones or large material will remain outside the screens. The revolution of the wheel is slow, and when any bucket has passed over the top center and begins to descend upon the other side, these stones or valueless material will be discharged by gravitation behind the wheel, and will leave the buckets clear to excavate another load, and the apparatus will be gradually advanced leaving this coarse material behind.

As it is necessary that the bed-rock be cut away to save all the valuable material which may have accumulated in crevices, the mouths of the buckets are provided with supplemental cutting edges of nickel steel or other resistant material 11, and these cutters may be replaced when required, thus saving the buckets.

In order to protect the submerged driving gears and associated parts from wear by contact with the erosive material that is being excavated, I have shown in Fig. 10 an inclosing housing 12^a within which these parts are inclosed, and the parts which might be subjected to wear, together with the lubricants employed, are thus maintained clean and with a minimum of wear.

It should be understood that the casing of the driving shaft extends above the water line, and that all joints below the water line are impervious to water.

Having thus described my invention, what I claim and desire to secure by Letters Patent is—

1. In a dredger, a float, a hinged ladder projecting therefrom, means for raising and lowering the front end of the ladder, a cutter wheel carried upon the front of said ladder said wheel having buckets with openings leading inwardly towards the center of the wheel, a suction chamber communicating with the said openings, and a suction pipe connecting with said chamber.

2. In a dredger, a float, a ladder hinged thereto, a cutter consisting of a revolving wheel, digging buckets carried on the periphery of said wheel, said buckets having openings on the side toward center of wheel, screening devices placed in said openings of buckets, passage-ways through cutter wheel leading from said openings in digging buckets to side outlet or outlets, a suction chamber to receive the material and a suction pipe connected therewith.

3. In a dredge, a float, a ladder hinged thereto, means for raising and depressing the ladder, a cutter wheel attached to the ladder, buckets attached to the periphery of

the wheel, said buckets having openings in the sides toward center of wheel, continuous passage-ways connecting said openings in buckets with side outlets of cutter wheel, screening devices placed at the entrance to the buckets, said passage-ways leading to side outlet, thence into suction chamber.

4. In a dredge, a float, a ladder hinged thereto, a cutter wheel attached thereto, buckets on the periphery of said wheel, passage-ways leading from said buckets to side outlets of the cutter wheel, said passage-ways formed of two side walls with dividing radial curved or straight blades extending from the periphery of the wheel to or near hub of wheel.

5. In a dredger, the combination of a float, a ladder hinged thereto, a cutter wheel attached to the ladder, said wheels having buckets with openings leading inwardly towards the center of the wheel and thence diverging towards the sides thereof, and suction means communicating with the inner ends of said openings.

6. In a dredge, a float, a ladder, a cutter wheel, a suction chamber, a suction pipe leading from said suction chamber, a connected centrifugal dredging pump, a hydraulic elevating device, a packed swivel joint permitting the raising or lowering of said cutting wheel, and maintaining an airtight joint at the side of the pump.

7. In a dredge, a float, a ladder, a cutter wheel, a suction chamber and pipe, a dredging pump and hydraulic elevator, a hydraulic nozzle so placed on above ladder as to permit water issuing therefrom to strike inside of cutter wheel buckets, water under pressure supplied thereto through pipe attached to ladder, thence to pressure pump.

8. The combination in an apparatus of the character described, of a cutter wheel having inclosed peripheral buckets with open fronts and cutting edges, said buckets having, also, openings leading inwardly towards the center of the wheel, guides extending inwardly from the rear of the buckets and forming walls of passages to which the said openings lead, a hub portion having a periphery which converges outwardly into said passage to deflect the material towards the outer sides of the wheel, suction chambers communicating with the passages, and suction pipes connecting with the chambers.

9. In an apparatus of the character described, a revoluble wheel, inclosed open mouth buckets located around the wheel periphery, a central discharge and screens or bars fixed between the mouths of the buckets and the discharge.

10. In an apparatus of the character described, a revoluble wheel with central discharge, inclosed open mouth buckets located around the wheel periphery, with inwardly directing guides at the rear, and screening

devices fixed between the mouths of the buckets and the discharge.

11. In an apparatus of the character described, a revoluble wheel with a central outwardly delivering discharge, a substantially continuous peripheral screen device, open mouth buckets fixed to the wheel exterior to the screen said buckets having inwardly convergent directing plates or surfaces.

12. In an apparatus of the character described, a revoluble wheel with a central discharge and peripheral screen surface, open mouth buckets located exterior to the screen, said buckets having removable cutting blades fixed around their mouths.

13. In an apparatus of the character described, a revoluble wheel having peripheral digging buckets and inwardly directing guides or blades, an annular central discharge opening with outwardly curved edges, and a central hub having its sides outwardly curved to correspond with the edges of the discharge openings of the wheel.

14. In an apparatus of the character described, a revoluble wheel having peripheral digging buckets and convergent inwardly directing guides, an annular outwardly divergent central discharge opening, a concave sided hub forming the inner surface of said

opening, exterior chambers with bearings for the wheel shaft, and annular inturned edges overlapping the edges of the wheel discharge openings, and suction pipes connecting with said chambers.

15. In a dredge, a float, a ladder hinged thereto, a cutter wheel attached thereto, a bucket on the periphery of said wheel, a passage-way leading from said bucket to side outlet of cutter wheel.

16. In an apparatus of the character described, a hollow excavating wheel or cutter, a suction pipe connected with the wheel, a driving shaft, gear and pinion through which motion is communicated to the cutter, and an inclosing housing for said moving parts.

17. In an apparatus of the character described, a cutting wheel, inclosed bearings for its journal-shaft, a driving shaft, pinion and gear through which motion is transmitted to the cutter, and an inclosing housing therefor.

In testimony whereof I have hereunto set my hand in presence of two subscribing witnesses.

ALFONSO LKIEVICZ.

Witnesses:

GEO. H. STRONG,
JESSIE C. BRODIE.