

Aug. 14, 1945.

B. CONES

2,382,003

CLOTHES CLOSET POLE

Filed Dec. 11, 1943

*Fig. 1.*

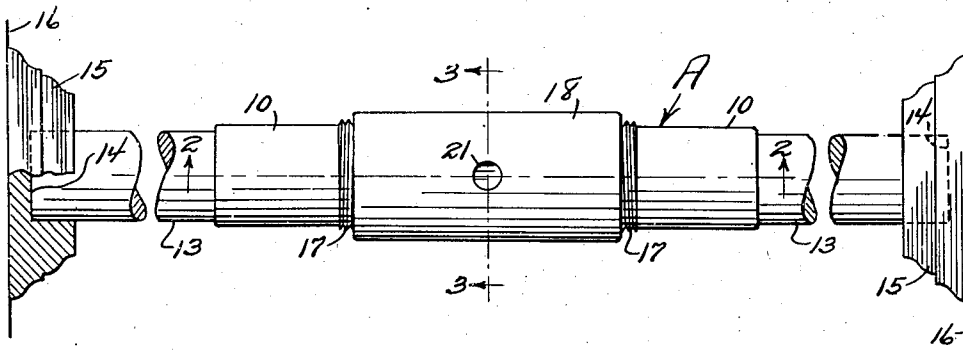

*Fig. 2.*

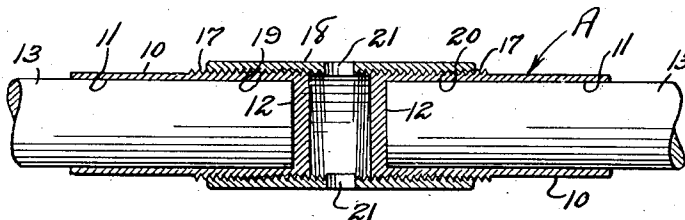

*Fig. 3.*

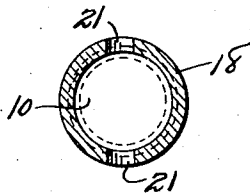

*Ben Cones*  
INVENTOR.

BY  
*Victor J. Evans & Co.*  
ATTORNEYS

# UNITED STATES PATENT OFFICE

2,382,003

## CLOTHES CLOSET POLE

Ben Cones, Indianapolis, Ind.

Application December 11, 1943, Serial No. 513,971

### 1 Claim. (Cl. 211—123)

The invention relates to a pole construction and more especially to a clothes hanger or pole for a closet or other like enclosure.

The primary object of the invention is the provision of a hanger or pole of this character, wherein the same is susceptible for adjustment so that the said hanger or pole can be properly fitted in supporting position for clothes within a closet or other like place, the hanger or pole being readily and easily placed or removed at will, and when in place will not become accidentally detached from its set position.

Another object of the invention is the provision of a hanger or pole of this character, wherein it possesses few parts, these being interfitted with each other for bridging a space within an enclosure, so that clothes or other articles can be conveniently hung therefrom, and will be properly supported when stored within the enclosure.

A further object of the invention is the provision of a hanger or pole of this character, wherein the ends thereof are socketed within bearings or fixtures adapted to be secured to a vertical support, so that the said hanger or pole will be horizontally maintained for the engagement of clothes hangers or racks therewith, the hanger or pole constituting the present invention being novel and unique in construction.

A still further object of the invention is the provision of a hanger or pole of this character, which is simple in construction, thoroughly reliable and efficient in purpose, strong, durable, reliable in the mounting thereof, assuring the proper placement of clothes or other like articles within an enclosure, and inexpensive to manufacture and install.

With these and other objects in view the invention consists in the features of construction, combination and arrangement of parts as will be hereinafter more fully described, illustrated in the accompanying drawing, which shows the preferred embodiment of the invention, and pointed out in the claims hereunto appended.

In the accompanying drawing:

Figure 1 is an elevation of a pole constructed in accordance with the invention in place within an enclosure.

Figure 2 is a fragmentary sectional view taken on the line 2—2 of Figure 1 looking in the direction of the arrows.

Figure 3 is a sectional view taken on the line 3—3 of Figure 1 looking in the direction of the arrows.

Similar reference characters indicate corresponding parts throughout the several views in the drawing.

Referring to the drawing in detail A designates generally the hanger or pole constructed in accordance with the invention and comprises a pair of outer capping members 10, which are of tubular formation, each having a socket 11 opening through one end, while the other end 12 is solid and closes the socket 11 at this end. Each socket 11 has telescopically fitted therein a rod-like section 13, which snugly fits into the companion capping member 10 at one end of such section, while the other end is accommodated in a seat 14 provided centrally in a circular fixture or bearing 15 adapted to be fixed to the vertical side of a support or wall 16 within an enclosure or other like place.

The capping members 10 are externally threaded at 17 for a distance next to their solid ends 12, and these latter ends are adjustably engaged in an internally threaded sleeve or coupling union 18, the threads 19 and 20, respectively, therein being reversely disposed, which is the case with the threads on the capping member 10, so that when the sleeve or union is adjusted the members will be brought toward or away from each other for the proper fitting of the hanger or pole A in place within the bearings 15 inside of an enclosure or other like place.

The collar or union 18 is provided with a key receiving hole 21 at diametrically opposite sides thereof, for accommodating a cross pin or key not shown so that the said collar or union can be readily turned or adjusted to regulate the disposition of the sections 13 with respect to each other in their coupling relation to one another in the fitting of the pole in place or its removal, the latter when in place being in a horizontal position for the hanging of garment hangers or the like thereon.

What is claimed is:

A clothes hanger pole structure, comprising a pair of spaced fixed sockets similarly formed, rod-like sections of equal length removably supported in said sockets in axial alinement with each other and their ends spaced a considerable distance apart, a capping member having a closed inner end fitting over the inner end of each of the rod-like sections and externally threaded in reverse direction in respect to each other, and a coupling union having a bore entirely there-through and internally threaded in an opposite direction starting at the center through the ends thereof, the coupling union having the capping members threaded therein.

BEN CONES.