

Nov. 15, 1966

A. FREI

3,285,144

HOOKS USED FOR FOLDING BACK FLAPS IN FOLDING-GLUEING MACHINES

Filed Jan. 20, 1964

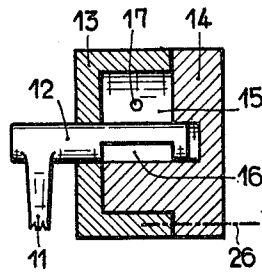
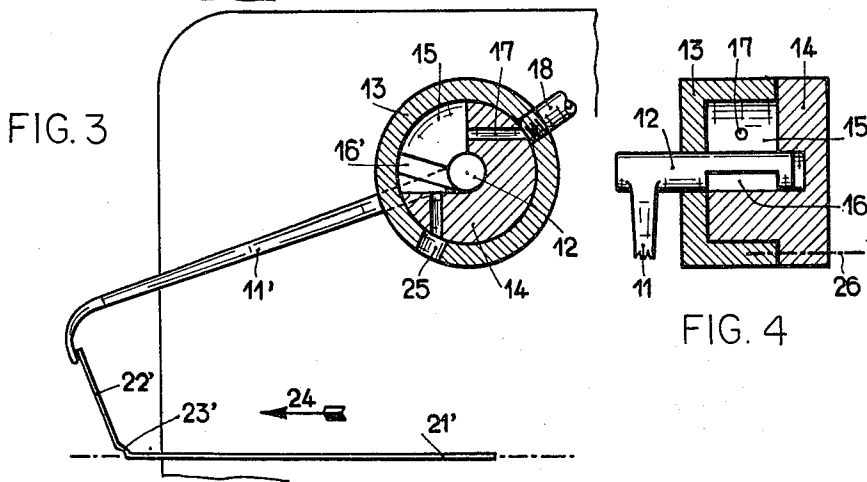
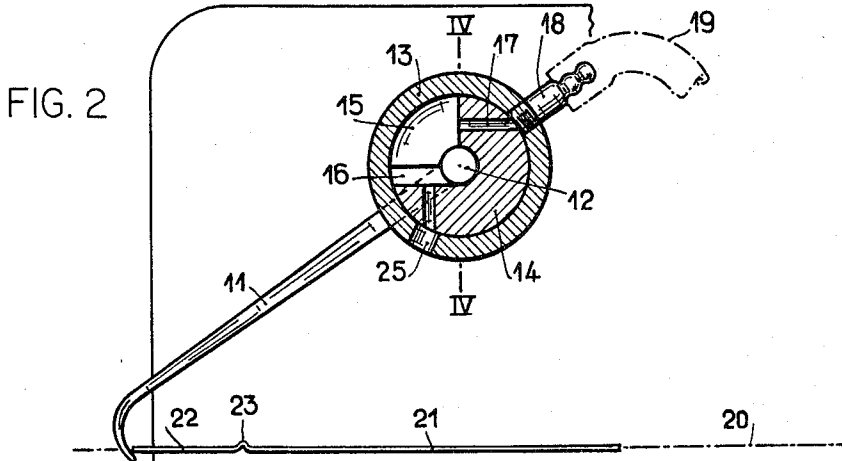
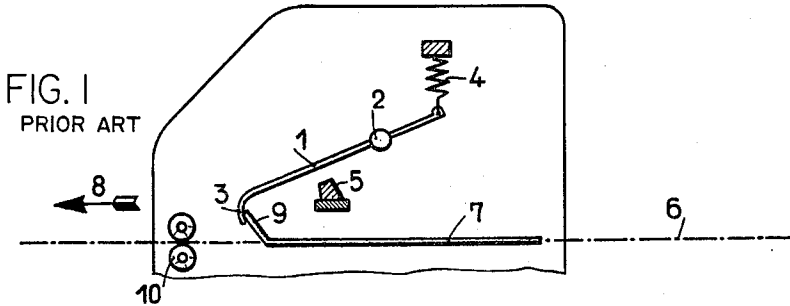

1

3,285,144

**HOOKS USED FOR FOLDING BACK FLAPS IN FOLDING-GLUEING MACHINES**

Arthur Frei, St. Sulpice, Switzerland, assignor to J. Bobst and Son S.A., Prilly, near Lausanne, Switzerland

Filed Jan. 20, 1964, Ser. No. 338,661

Claims priority, application Switzerland, Apr. 23, 1963, 5,174/63

4 Claims. (Cl. 93—49)

This invention relates to the use of hooks for folding flaps, for instance in assembling or gluing flaps of punched cardboard pieces to form boxes in so-called folding-gluing machines.

The conventional hooks employ springs which must be independently regulated for each hook.

An object of the invention is to provide an improved hook which avoids the use of springs.

A further object of the invention is to utilize hydraulic means to act on the hooks to operate the same and to avoid the need for independent regulation of each hook.

The invention will next be described in detail in conjunction with the attached drawing, wherein:

FIGURE 1 is a diagrammatic representation of a conventional hook as employed in the prior art;

FIGURES 2 and 3 are diagrammatic representations of a hook arrangement according to the invention in different stages of operation; and

FIGURE 4 is a sectional view taken along lines IV—IV in FIG. 2.

The hook in FIG. 1 is comprised of a shank 1 pivotally mounted on a shaft 2, and terminated by a hook portion 3. A spring 4 acts on the end of shank 1 remote from the hook portion 3 to urge the shank against the stop 5.

In the rest position, the hook is in contact with stop 5 and is in the trajectory 6 of punched cardboard pieces 7 being shifted in the direction of the arrow 8. Each piece 7 comprises, for instance a flap 9, which the hook 3 folds back.

In FIG. 1 the flap is partially raised, while the hook has pivoted around shaft 2 against the action of spring 4.

At a particular position of the advancing piece 7, the flap 9 is sufficiently folded and escapes the hook 3, and its folding is completed for instance by running between cylinders 10. Under the action of its spring, the hook returns to its starting position against stop 5 as soon as the piece 7 advances sufficiently and the operation starts again at the passage of each new cardboard piece.

The tension of the spring 4 is usually adjustable, because it is necessary to adapt it, not only to the force of the cardboard to be folded, but also to the amplitude of the oscillation depending in turn on the size of the flap to be folded back. Also generally, a series of flaps, deposed side by side are folded back simultaneously on a common folding line. In this case several hooks disposed side by side are utilized and it is necessary to regulate the machine when working, to adjust each hook spring separately.

This requires a stopping of the machine for, if during operation, only the tension of one of the springs is changed, there results therefrom an unbalance likely to give rise to improper folding of a piece making it necessary to immobilize the machine.

The hook according to the invention eliminates this drawback.

This is obtained by bringing the hook back to its starting position by a compressible fluid under pressure.

2

The resistance applied to the hook thus depends on the fluid pressure, and it will then be easy to subject a battery of such hooks to the said pressure and to modify simultaneously their operation by merely changing the said pressure.

In the hook arrangement according to the invention in FIGS. 2-4, the hook is shown at 11 in the first position in FIG. 2 and at 11' in the second position in FIG. 3.

The hook is connected to a shaft 12, turning inside a cylindrical support made up of two parts 13 and 14, of which part 13 forms a socket covering a central cap of part 14 as seen in FIG. 4. However, this cap does not entirely fill the socket, leaving therein a segment or sector shaped recess 15 extending practically over a quarter of a circle.

In this housing there is mounted a swingable blade 16, integral with the shaft 12 and forming therein a rotatory piston capable of compressing an elastic fluid, in particular air under pressure, enclosed in the recess 15.

A bore 17, connected to a spigot 18, enables interconnection of all the hooks by a conduit 19 adapted for distributing air under regulable pressure.

In the rest position of the hooks in FIGS. 2 and 4, the blade 16 contacts a wall of the recess 15, which acts as a stop for the rotation of the hook 11. The hook is in the trajectory 20 of the piece 21, of which one flap 22 is to be folded back around the folding line represented by the bend 23.

As the piece advances in the direction of the arrow 24 (FIG. 3), the cardboard piece reaches the position in which its flap held back by the hook is raised at 22', while the hook is swung to 11'.

The blade 16 taking part in this motion is shifted to the position at 16', compressing the air enclosed in the recess 15 and in the bores and conduits in communication therewith. This compression produces the required effect of elasticity, tending to bring the hook back to its starting position with a force depending on the pressure.

An opening 25 establishes communication between the atmosphere and the blade opposite to that put under pressure, so as to cancel any action on that side from the latter.

The regulation of the pressure on which depends the resistance opposed by the hook can be effected by any suitable means. For example, one or several parallel connected hooks can be connected to a space of variable volume.

Both parts 13 and 14 of the box are assembled for instance by means of fasteners along the axis 26. Such fasteners and necessary seals are not illustrated in order not to complicate the drawing.

What I claim is:

1. A hook adapted for being pivotally mounted in the path of advancement of a carton blank to effect folding of a flap of the blank, said hook comprising a shank with a terminal hook portion, a shaft rotatably supporting said shank, a housing having a recess receiving said shaft, and a blade disposed in said recess and secured with said shaft for rotation therewith, said recess being adapted for containing a compressible pressure fluid which is subjected to pressure upon rotation of the blade in said recess, thereby urging the blade to return to its original position.

2. A hook as claimed in claim 1, wherein said housing has a wall bounding said recess, said blade having an initial position in contact with said wall to establish a rest position for the shank in which said hook portion is able to contact a flap of an advancing blank.

3,285,144

3

3. A hook as claimed in claim 2, wherein said wall has an opening therein which is in communication with the atmosphere.

4. A hook as claimed in claim 2, wherein said housing has a bore opening into said recess and adapted for connection with a corresponding bore of another hook. 5

4

References Cited by the Examiner

UNITED STATES PATENTS

2,597,050	5/1952	Audemar	-----	60—54.5
2,879,699	3/1959	Labombarde	-----	93—49

BERNARD STICKNEY, *Primary Examiner.*