

Jan. 27, 1953

O. G. TILTON
MACHINE FOR CLEANING THE WATER SPACES OF RADIATORS
AND ENGINE BLOCKS OF MOTOR VEHICLE POWER PLANTS
Filed March 3, 1950

2,626,623

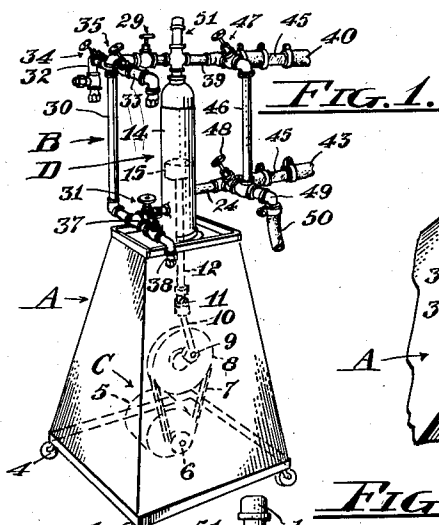

FIG. 1.

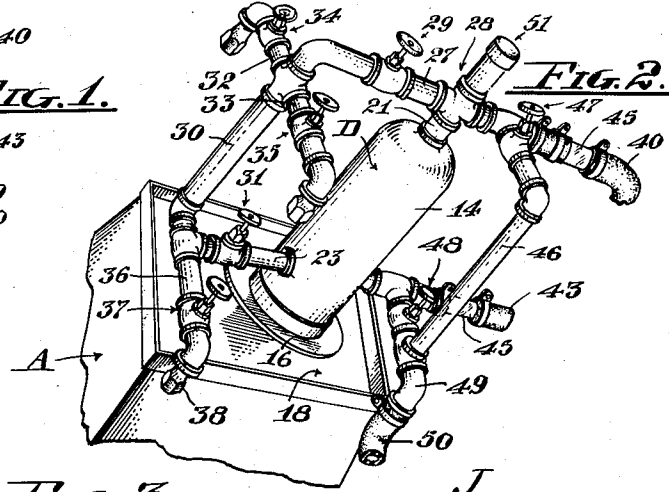

FIG. 2.

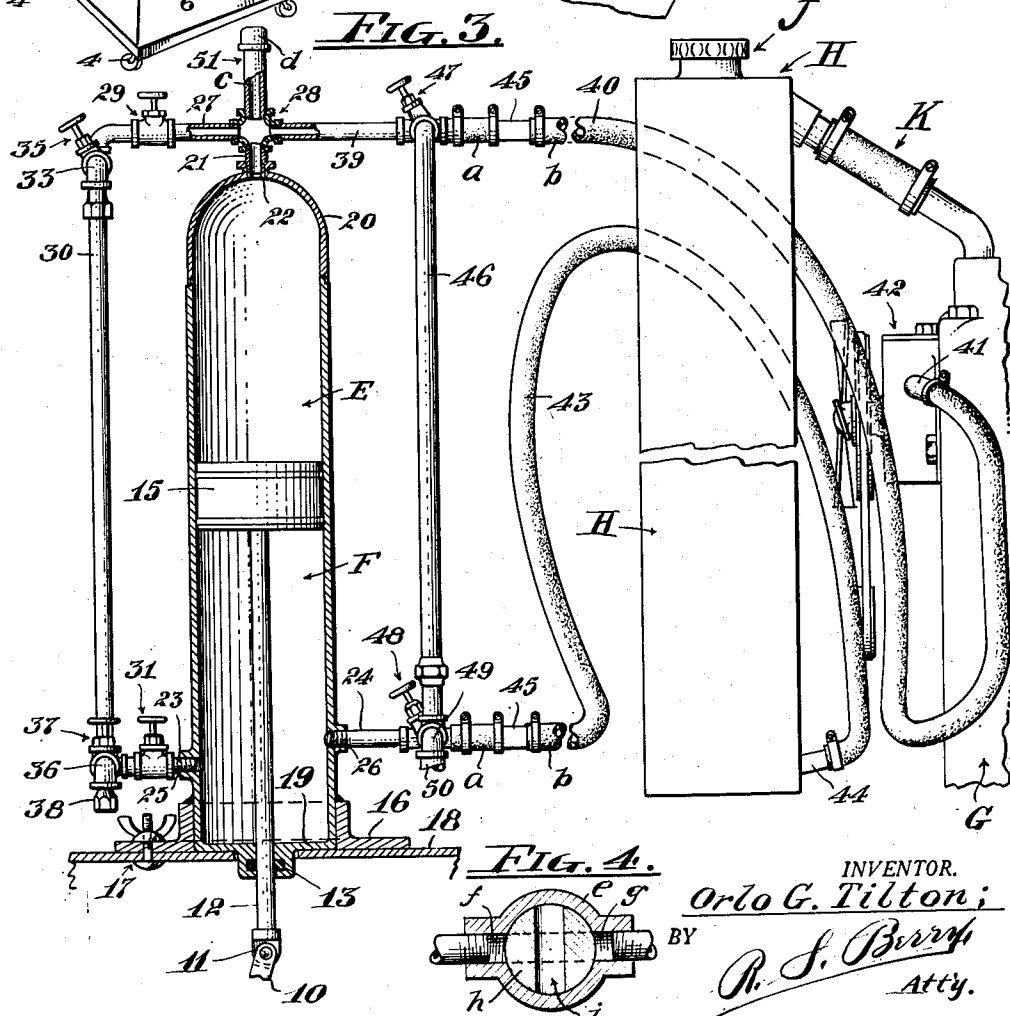

FIG. 3.

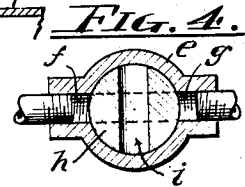

FIG. 4.

INVENTOR.
Orlo G. Tilton;
BY *R. J. Berry*
Atty.

UNITED STATES PATENT OFFICE

2,626,623

MACHINE FOR CLEANING THE WATER SPACES OF RADIATORS AND ENGINE BLOCKS OF MOTOR VEHICLE POWER PLANTS

Orlo G. Tilton, Fullerton, Calif.

Application March 3, 1950, Serial No. 147,402

3 Claims. (Cl. 134—98)

1

This invention relates to a machine for cleaning the water spaces in the radiators and engine blocks of motor vehicles and has as its primary object the provision of a mechanism whereby a cleansing fluid may be surged back and forth through the water spaces in such fashion as to loosen and remove accumulations and deposits of solids from the water spaces and from the walls thereof.

Another object is to provide a machine of the above character which is applicable to both the radiator and engine block in a manner to effect cleansing of the water spaces of each at the same time and while in place on the vehicle, thus obviating dismounting of either the engine block or radiator for the purposes of effecting cleansing the interiors thereof.

Another object is to provide a radiator and engine block cleaner of the type embodying a double acting piston pump for surging the cleansing fluid back and forth in the water spaces of the radiator and engine block together with a pair of flexible conduits leading from the combined inlets and outlets of the pump adapted to be connected respectively to a radiator outlet and to the water inlet of the engine block, which is equipped with a series of control valves whereby the flow of the cleansing fluid may be directed and regulated as occasion may require.

A further object is to provide a construction in the machine whereby a chemical solution and flushing water may be separately directed to and from the water spaces to be cleansed as needed, and to also provide a means whereby the cleansing fluid, either the chemical solution or water, may be directed to waste on completion of the cleansing operation.

A further object is to provide means for enabling the operator to determine at all times while the machine is in operation the condition of the cleansing fluid being pumped through the water spaces of the radiator and engine block, so as to enable changing of the cleansing fluid when need be or to enable termination of the operation when completion thereof is indicated.

With the foregoing objects in view, together with such other objects and advantages as may subsequently appear, the invention resides in the parts and in the combination, construction and arrangement of parts hereinafter described and claimed, and illustrated by way of example in the accompanying drawing, in which:

Fig. 1 is a perspective view of the machine with portions of the flexible conduits removed;

Fig. 2 is a diagram in perspective of the head

2

portion of the machine showing it in an inclined position and as seen from above to clearly depict various parts thereof;

Fig. 3 is a view in vertical section and side elevation of the head portion of the machine and illustrating the manner of connecting it to the radiator and engine block; and

Fig. 4 is a diagram in horizontal section of the conventional cut-off valve employed in the machine showing it in its closed position in full lines and in its open position in dotted lines.

Referring to the drawing more specifically A indicates the base of the machine which is supported on castors 4 to facilitate its movement from place to place over a floor, and B designates generally the head portion of the machine which is carried on and affixed to the base A.

The base A is here shown as comprising a hollow four sided pyramidal structure within which is mounted a driving mechanism C including an electric motor 5 fitted with a driving pulley 6. A belt 7 passes around the driving pulley 6 and around a driven pulley 8 which latter is equipped with a wrist pin 9 fitted with a connecting rod 10. The outer end of the rod 10 is pivotally connected at 11 to a vertically extending piston rod 12 which leads through a packing gland 13 into the upright cylinder 14 of a double acting reciprocal piston pump D and is provided at its upper end with a piston 15 slidably fitted in the cylinder 14 in a manner common to pumps of this character. The pump cylinder 14 is provided with a base flange 16 which is rigidly fastened by bolts and nut assemblies 17 to a top wall 18 fixed on the base A.

The pump cylinder 14 is closed at its lower end by a wall 19 which carries the packing gland 13 and through which the piston rod 12 slidably extends, while the upper end of the pump cylinder is closed by a dome shaped cap 20.

The foregoing described structure is that of an ordinary double acting reciprocal pump assemblage and accordingly involves no invention other than as an element of the machine. The essence of the present invention resides in the combination and arrangement of parts attached to the pump D whereby it is adapted for the use for which it is intended. These parts, as will now be described, include a nipple 21 fitted in an opening 22 in the cap 20 and a pair of nipples 23 and 24 fitted in openings 25 and 26 in opposed wall portions of the pump cylinder adjacent the lower end thereof. A conduit 27 is connected to the nipple 21 by a coupling 28 and leads through a cut-off valve 29 to a downwardly extending

conduit 30 connecting with the nipple 23 through a cut-off valve 31; the conduits 27 and 30 with the nipples 21 and 23 providing a communication between the upper and lower chambers E and F of the pump cylinder on opposite sides of the piston 15 which communication is normally closed by the valves 29 and 31.

Leading laterally from the juncture of the conduits 27 and 30 are feed pipes 32 and 33 fitted with cut-off valves 34 and 35 respectively which pipes are designed to be connected to sources of supply of different cleansing liquids under pressure comprising a supply of fresh water and a supply of a suitable chemical solution.

Connecting with the lower portion of the conduit 30 is a drain pipe 36 fitted with a cut-off valve 37 and having a hose connecting terminal 38 to which a hose may be attached if desired to direct liquid from the drain pipe to a suitable point of discharge.

Leading from the upper end of the pump cylinder is a conduit 39, here shown as attached to the coupling 28, the outer end of which conduit 39 is connected to one end of a length of hose 40 the outer end of which is adapted to be connected to either the main outlet of a radiator or to the water intake of an engine block and being here shown as attached to the intake 41 of the conventional water circulating pump 42 of an engine block G. The outer end of the conduit 24 is connected to one end of a length of hose 43 the other end of which is adapted to be connected to either water intake of the engine block or to the main outlet of a radiator, and being here shown as attached to the outlet 44 at the lower end of a radiator H. As a means for enabling the operator to observe the condition of liquid flowing through the hose 40 and 43, a transparent tube 45 of glass or the like is mounted to extend between spaced sections *a* and *b* of each of the hose so that liquid directed through the hose and tubes will be visible at all times.

Connecting the conduits 39 and 24 is a drain pipe 46 the ends of which connect with the conduits 39 and 24 through cut-off valves 47 and 48 respectively, and leading from the lower end of the pipe 40 is a coupling 49 to which is connected a waste hose 50 leading to any suitable point of discharge.

The coupling 28 is here shown as comprising a +-coupling, the stem of which is connected to the nipple 21 and to the opposed sides of which is connected the conduits 27 and 39. To the other upwardly extending end of the coupling 28 is attached an upright post 51 comprising a tube *c* closed at its outer end by a cap *d*, which post serves as a support around which the lengths of hose 40, 43 and 50 may be draped when not in use and particularly when moving the machine so as to then avoid dragging the hose. The several cut-off valves above referred to constitute the ordinary hand operated cut-off valves commonly employed in water pipes or conduits, and are selectively manually opened and closed by the operator according to the operations to be performed; all of the valves being closed when the machine is not in use. This type of valve is diagrammatically illustrated in Fig. 4 and comprises a housing *e* having opposed ports *f* and *g* from which lead the conduits or pipes for conducting liquid the flow of which is to be controlled by the valve; the housing being fitted with a valve member *h* comprising a turnable cylinder formed with a transverse passage *i* which, on

rotation of the cylinder may be positioned either out of register with the ports *f* and *g* as shown in full lines to close the valve, or may be disposed in register with the ports *f* and *g* as indicated in dotted lines, to open the valve.

In the application of the invention, when it is desired to effect cleaning of the water spaces of the engine block and the radiator in a single operation while mounted on a motor vehicle, the cleaning machine is moved to a convenient point adjacent to the vehicle, and after draining the water spaces of the engine block and radiator and removing the usual connection between the lower end of the radiator and the intake of the water circulating pump 41 on the engine block, the outer end of the hose 40 is connected to the intake 41 and the outer end of the hose 43 is connected to the radiator outlet 44. However, as before stated, either hose 40 or 43 may be connected to the engine water intake 41 or the radiator outlet 44 as occasion may require or as may be most convenient. Before connecting the hose to the radiator and engine block the water spaces may be flushed if desired. On connecting the machine to the radiator and engine block as stated, the water spaces therein are filled with a suitable chemical solution capable of effecting a cleansing action on the walls of the water spaces and of dissolving any encrustations thereon. This solution may be introduced into the water spaces of the engine block and the radiator through the radiator intake *J* and filling the radiator in the usual fashion, or the spaces may be filled by liquid delivered thereto through certain of the conduits of the machine where the latter is connected to sources of liquid supply through the pipes 32 and 33, in which case, assuming the pipe 32 to be connected to a source of water supply under pressure, water may be directed into the water spaces of the engine block and radiator by opening valves 34 and 29, or valves 34 and 31, or both. In event it is desired to effect the flow of water through the water spaces, as in flushing same, valves 34, 29 and 48 are opened, whereupon water directed into the water spaces in the engine block through the hose 40 will flow from the engine block through the usual connection *K* between it and the upper portion of the radiator, then pass from the lower end of the radiator through the hose 43 through the conduit 49 and valve 43 to waste through the hose 50.

When it is desired to fill the water spaces of the engine block of the radiator with a cleansing solution, assuming the pipe 33 as being connected to a source of such solution, valve 35 together with valves 31 and 29 are open so as to thereby direct the cleansing fluid into the water space in the engine block and of the radiator through the hose 40 and 43.

Manifestly, on opening the valve 34, or 35, and valves 29 and 31, liquid will be delivered from the supply source into the pump chambers E and F; opening of valve 29 when either valve 34 or 35 is opened, directing liquid into chamber E above the piston 15, and opening of valve 31 when either valve 34 or 35 is opened, directing liquid into chamber F below the piston. In initially delivering liquid to the pump cylinder air may be entrapped therein particularly if the piston is in an elevated position, but operation of the pump will soon effect replacement of the air with liquid. However it will be apparent that the pump spaces may be supplied with liquid from the radiator and engine block since on filling these

5

spaces through the radiator inlet J and opening the valves 29 and 31 with the other valves closed, liquid may flow back through the hose 40 and 43 into the pump chambers and into the then communicating conduits and pipes. The cleansing solution is then caused to surge back and forth in the water spaces of the engine block and radiator by setting the motor 5 in operation thereby effecting reciprocation of the pump piston 15 in the cylinder 14, whereupon, on upstroke of the piston the liquid confined in the pump space E will be directed through the nipple 21, conduit 39 and hose 40 to the water space intake of the engine cylinder and then to the upper portion of the radiator and displacing the liquid contained in the latter through the hose 43 and conduit 24 into the space F beneath the piston 15 as the latter advances on its upper stroke. On downstroke of the piston the operation and direction of flow of liquid will be reversed.

This operation is continued until by observation of the condition of the liquid as it passes through the transparent tubes 45, it is determined that change of the cleansing liquid is desired whereupon the cleansing fluid is flushed from the engine block and radiator by closing valve 35 and opening valves 31, 37 and 43 thereby allowing the liquid to flow to discharge through the pipe 36 and conduit 50. Additional charges of cleansing solutions may be used as stated, if need be.

After completion of the use of the solutions, the water spaces are rinsed by directing fresh water therethrough as before described, and if found desirable the rinse water may be surged back and forth in the water spaces by setting the pump D in operation as above described.

On completion of the operations water is drained from the radiator and the hose 40 and 43 are detached from the engine block and radiator connections 41 and 44 and replaced by the usual connections between the radiator outlet 44 and the pump intake 41.

From the foregoing it will be seen that by the use of the invention, cleansing of the water spaces of the engine block and radiator of a motor vehicle power plant may be effected without removing the radiator or the block from the vehicle.

While I have shown and described a specific embodiment of my invention, I do not limit myself to the exact details of construction set forth, and the invention embraces such changes, modifications and equivalents of the parts and their formation and arrangement as come within the purview of the appended claims.

I claim:

1. In a machine for cleaning the water spaces of radiators and engine blocks of motor vehicle power plants, including a pump embodying a

6

cylinder with a reciprocal piston therein and having end portions formed with combined inlet and outlet openings, a conduit leading from each of said openings, and a hose attached to each of said conduits for connection with the water spaces of a radiator and an engine block; a liquid supply pipe connected to an end of the pump cylinder through the opening therein and to the conduit leading therefrom to direct liquid from said supply pipe to one end of the pump cylinder and directly from said supply pipe to the conduit leading therefrom, a cut-off valve in said pipe, a pipe leading from said supply pipe into the lower end portion of said pump cylinder, a cut-off valve in said last named pipe, a drain pipe connecting with said last named pipe, and a cut-off valve in said drain pipe.

2. The structure called for in the preceding claim together with a drain pipe connecting with each of said conduits, and a cut-off valve between each of said conduits and said drain pipe.

3. In a machine for cleaning the water spaces of radiators and engine blocks of motor vehicle power plants, including a pump embodying a cylinder with a reciprocal piston therein and having end portions formed with combined inlet and outlet openings, a conduit leading from each of said openings, and a hose attached to each of said conduits for connection with the water spaces of a radiator and engine block; a pair of connected liquid supply pipes, a cut-off valve disposed in each of said liquid supply pipes, a direct valve controlled connection between said supply pipes and one of the conduits leading from an end opening of said pump cylinder whereby a liquid may selectively be delivered from either or both of said supply pipes co-incidentally to one end of the pump cylinder and to the water spaces of the radiator and engine block, a supply conduit leading from said connected supply pipes to the other end of said pump cylinder, a cut-off valve in said supply conduit, a valve controlled drain pipe leading from said supply conduit, and a valve controlled drain pipe leading from each of the conduits leading from the end openings of said pump cylinder.

ORLO G. TILTON.

REFERENCES CITED

The following references are of record in the file of this patent:

UNITED STATES PATENTS

| Number | Name | Date |
|-----------|--------------|---------------|
| 918,091 | Roche | Apr. 13, 1909 |
| 1,804,536 | Ludwig | May 12, 1931 |
| 1,918,048 | Marxman | July 11, 1933 |
| 2,187,413 | Boezi et al. | Jan. 16, 1940 |
| 2,510,701 | La Cross | June 6, 1950 |