



(11) **EP 2 016 845 A2**

(12) **EUROPEAN PATENT APPLICATION**

(43) Date of publication:
21.01.2009 Bulletin 2009/04

(51) Int Cl.:
A42B 3/04 (2006.01)

(21) Application number: **08252472.9**

(22) Date of filing: **21.07.2008**

(84) Designated Contracting States:
**AT BE BG CH CY CZ DE DK EE ES FI FR GB GR
HR HU IE IS IT LI LT LU LV MC MT NL NO PL PT
RO SE SI SK TR**
Designated Extension States:
AL BA MK RS

(30) Priority: **20.07.2007 US 961627 P**

(71) Applicant: **Koehler-Bright Star Inc.
Hanover Township, PA 18708 (US)**

(72) Inventors:
• **Bobbin, Joseph J.
Nanticoke, PA 18634 (US)**
• **Dirsa, Mark F.
Shavertown, PA 18708 (US)**
• **Devaney, John
Montain Top, PA 18707 (US)**

(74) Representative: **Dauncey, Mark Peter et al
Marks & Clerk
Sussex House
83-85 Mosley Street
Manchester M2 3LG (GB)**

(54) **Electronic module adapter for headgear**

(57) An electronic module adapter for headgear includes a housing defining a chamber. A clip is positioned on the housing and is adapted to attach the housing to the helmet or other headgear. A cap lamp mounting bracket is optionally positioned on the housing and is

adapted to attach a cap lamp to the housing. Electronic circuitry is positioned within the chamber of the housing and may include a radio frequency identification tag, a global positioning system tag and/or a gas sensor.

EP 2 016 845 A2

Description

CLAIM OF PRIORITY

[0001] This application claims priority from U.S. Provisional Patent Application Serial No. 60/961,627, filed July 20, 2007.

FIELD OF THE INVENTION

[0002] The present invention relates to accessories for protective headgear and, more particularly, to an electronic module adapter that mounts on a helmet or other headgear.

BACKGROUND

[0003] Different types of protective headgear, such as helmets and hard hats, are typically worn by fire fighters, rescue personnel and in industries where protection of the head from falling debris or the like is necessary. Such industries include, but are not limited to construction and mining.

[0004] Oftentimes it is desirable to attach electronic modules, such as radio frequency identification (RFID) tags, global positioning system (GPS) tags, and natural gas sensor tags to protective headgear. For example, modern day mines often include a miner tracking system so that the location of miners may be tracked for safety purposes. Such systems often include sensors positioned throughout the mine shafts. A miner wears an RFID tag which broadcasts a signal including the identity of the miner wearing the RFID tag. When the miner passes a miner tracking system sensor, the sensor receives the signal from the RFID tag. The sensors communicate with a central computer which tracks the location of miners wearing the RFID tags based on which sensors have received signals from the miners' RFID tags.

[0005] Like the other types of electronic modules, RFID tags must receive electrical power to operate. Mining cap lamps are typically mounted on helmets worn by miners to provide illumination in underground mine shafts. Such cap lamps are well known in the mining equipment industry and provide illumination while the miner's hands remain free to perform tasks. A cap lamp typically receives power from a battery power pack secured to the user's waist. Electrical wiring delivers power from the power pack to the lamp on the helmet. Traditionally, wires have been soldered to the battery terminals of the cap lamp power pack and to the RFID tags so that the RFID tags receive power from the battery of the cap lamp power pack. A problem with such an arrangement, however, is that such modifications are time consuming and inconvenient. In addition, and more importantly, the quality of the soldered connections is often inconsistent which leads to reliability issues, especially in the harsh mining environment. The exposed wires of such a power takeoff are also exposed which makes them even more vulner-

able to damage.

[0006] A need therefore exists for a device whereby electronic modules such as RFID tags, GPS tags and/or natural gas sensor tags may be securely and safely mounted to the protective headgear of miners, rescue workers or other individuals.

BRIEF DESCRIPTION OF THE DRAWINGS

[0007] Fig. 1 is a perspective view of a helmet with a cap lamp secured thereto by an embodiment of the electronic module adapter of the present invention;

[0008] Fig. 2 is an enlarged perspective view of the front portion of the helmet, the cap lamp and the electronic module adapter of Fig. 1;

[0009] Figs. 3 and 4 are perspective exploded views of the helmet, cap lamp and electronic module adapter of Figs. 1 and 2;

[0010] Fig. 5 is an enlarged bottom and back perspective view of the electronic module adapter of Figs. 1-4 with the housing lid removed;

[0011] Fig. 6 is a cross-sectional view of the electronic module adapter of Fig. 5 taken along line 6-6 of Fig. 5;

[0012] Fig. 7 is a top and front perspective view of the electronic module adapter of Fig. 5 with the housing lid attached;

[0013] Fig. 8 is an exploded perspective view of the electronic module adapter of Fig. 7.

DETAILED DESCRIPTION OF EMBODIMENTS

[0014] While the invention is described below in terms of use with a helmet, radio frequency identification (RFID) tag and cap lamp for mining, it is to be understood that it may be applied to other types of headgear and electronic modules. Such electronic modules may include, for example, global positioning system (GPS) tags, and natural gas sensor tags.

[0015] A helmet, such as used in mining, is indicated at 12 in Figs. 1-4. As illustrated in Fig. 1, the helmet includes a front panel 14 and a visor 16. A cap lamp is indicated at 18 in Figs. 1-4. As an example only, the cap lamp may be a model LI-16 cap lamp sold by Koehler-Bright Star, Inc. of Hanover Township, PA. As is known in the art, the cap lamp receives power via a power cord, indicated at 22 in Figs. 1 and 2, from a battery pack (not shown) typically worn strapped to the waist of the miner or in another location. The cap lamp 18 is typically mounted to the front panel 14 of the helmet by a clip positioned on the back side of the cap lamp. This clip typically engages a slot, such as the one indicated at 19 in Fig. 3. As a result, the cap lamp may be removed from the helmet for recharging or servicing.

[0016] In accordance with the present invention, the helmet clip normally used to mount the cap lamp to the helmet is removed from the cap lamp. An electronic module adapter, indicated in general at 23 in Figs. 1-7, includes a housing 24 that, as explained in greater detail

below, defines a chamber which houses electronic module circuitry and batteries. For example, the electronic module circuitry may be a self powered RFID tag (printed circuit board with three coin cell batteries). Alternatively, the electronic module adapter may act as a mounting point (like a docking station) or power source, with batteries present in the electronic module adapter, for a variety of interchangeable electronic devices. Instead of batteries, the electronic module adapter may receive power from the power cord 22 (Fig. 1).

[0017] As indicated in Figs. 1-4, the electronic module adapter housing 24 mounts to the cap lamp with two screws 26a and 26b via a cap lamp mounting bracket. The cap lamp mounting bracket features a pair of flanges 28a and 28b (Figs. 3-5 and 7) formed on the front side of the housing. The flanges 28a and 28b include mounting holes, indicated at 30a and 30b in Figs. 3 and 7, through which the screws 26a and 26b pass. The cap lamp mounting bracket may feature an alternative arrangement, such as a clip that engages the cap lamp or a recess that receives a clip mounted on the cap lamp.

[0018] As illustrated in Figs. 5-8, a headgear mounting bracket in the form of helmet clip 32 is attached to the back side of the electronic module adapter housing 24. More specifically, as illustrated in Fig. 8, the clip 32, which in the illustrated embodiment is made of metal, is secured to the housing via screws 34a and 34b, which engage openings 36a and 36b (not shown) formed in the housing 24. Alternatively, the clip 32 may be formed of plastic and either attached to or integrally molded with the housing 24. The housing 24 may also be constructed of metal with the clip 32 attached to it or integrally formed with the housing.

[0019] As illustrated in Figs. 1-4, the helmet clip 32 (headgear mounting bracket) of the electronic module adapter 23 attaches to the front panel 14 of the helmet 12 and takes the place of the original cap lamp helmet clip. As a result, the helmet clip of the electronic module adapter is used to mount the whole assembly (including the electronic module adapter and cap lamp) to the helmet. The headgear mounting bracket may take a variety of alternative forms as long as it engages the helmet so as to secure the electronic module adapter housing thereto.

[0020] As illustrated in Figs. 5, 6 and 8, electronic module circuitry in the form of a circular circuit board 40 has mounted thereon a stack of battery coin cells 42, which provide power to the circuit board 40. The electronic module circuitry circuit board may be for a variety of electronic functions, including, but not limited to, an RFID tag, a GPS tag and/or a natural gas sensor. As illustrated in Figs. 5, 6 and 8, the circuit board and batteries are inserted into the chamber 43 defined by the electronic module adapter housing 24 and the bottom is closed with bottom lid 44 (Figs. 7 and 8), which may be sealed to keep dust and dirt out of the interior of the electronic module adapter. As noted previously, the batteries 42 may be omitted if the circuit board instead receives power

from the cap lamp power cord 22 (Fig. 1).

[0021] The circuit board and batteries may be secured within the chamber 43 by adhesive, screws or other fastening arrangements known in the art. The bottom lid 44 may be attached to the housing 24 by adhesive, screws or other fastening arrangements known in the art.

[0022] While the preferred embodiments of the invention have been shown and described, it will be apparent to those skilled in the art that changes and modifications may be made therein without departing from the spirit of the invention, the scope of which is defined by the appended claims.

15 Claims

1. An electronic module adapter for headgear comprising:
 - a) a housing defining a chamber;
 - b) a clip positioned on the housing, said clip adapted to attach the housing to the headgear; and
 - c) electronic module circuitry positioned within the chamber of the housing.
2. The electronic module adapter of claim 1 wherein the electronic module circuitry includes a radio frequency identification tag.
3. The electronic module adapter of claim 1 wherein the electronic module circuitry includes a global positioning system tag.
4. The electronic module adapter of claim 1 wherein the electronic module circuitry includes a gas sensor.
5. The electronic module adapter of claim 1 wherein the clip is secured to the housing by screws.
6. The electronic module adapter of claim 1 wherein the clip is integrally formed with the housing.
7. The electronic module adapter of claim 1 wherein the electronic module circuitry includes a battery.
8. An electronic module adapter for a helmet comprising:
 - a) a housing defining a chamber;
 - b) a helmet mounting bracket positioned on the housing, said helmet mounting bracket adapted to attach the housing to the helmet;
 - c) a cap lamp mounting bracket positioned on the housing, said cap lamp mounting bracket adapted to attach a cap lamp to the housing; and
 - d) electronic module circuitry positioned within the chamber of the housing.

9. The electronic module adapter of claim 8 wherein the electronic module circuitry includes a radio frequency identification tag.
10. The electronic module adapter of claim 8 wherein the electronic module circuitry includes a global positioning system tag. 5
11. The electronic module adapter of claim 8 wherein the electronic module circuitry includes a gas sensor. 10
12. The electronic module adapter of claim 8 wherein the helmet mounting bracket includes a clip adapted to be received by a recess in the helmet. 15
13. The electronic module adapter of claim 12 wherein the clip is secured to the housing by screws.
14. The electronic module adapter of claim 12 wherein the clip is integrally formed with the housing. 20
15. The electronic module adapter of claim 8 wherein the cap lamp mounting bracket includes a first flange.
16. The electronic module adapter of claim 15 wherein the cap lamp mounting bracket includes a second flange spaced from the first flange so that a portion of a cap lamp may be received and secured there between. 25
30
17. The electronic module adapter of claim 16 wherein the flanges includes mounting holes through which screws may engage a housing of the cap lamp.
18. The electronic module adapter of claim 8 wherein the electronic module circuitry includes a battery. 35
19. A method for mounting an electronic module to a helmet featuring a cap lamp comprising the steps of: 40
- a) providing a housing defining a chamber, said housing having a helmet mounting bracket and a cap lamp mounting bracket positioned thereon;
 - b) positioning the electronic module circuitry within the chamber of the housing; 45
 - c) attaching the housing to the helmet using the helmet mounting clip; and
 - d) attaching the cap lamp to the housing using the cap lamp mounting bracket. 50
20. The method of claim 19 wherein the electronic module circuitry includes a radio frequency identification tag. 55

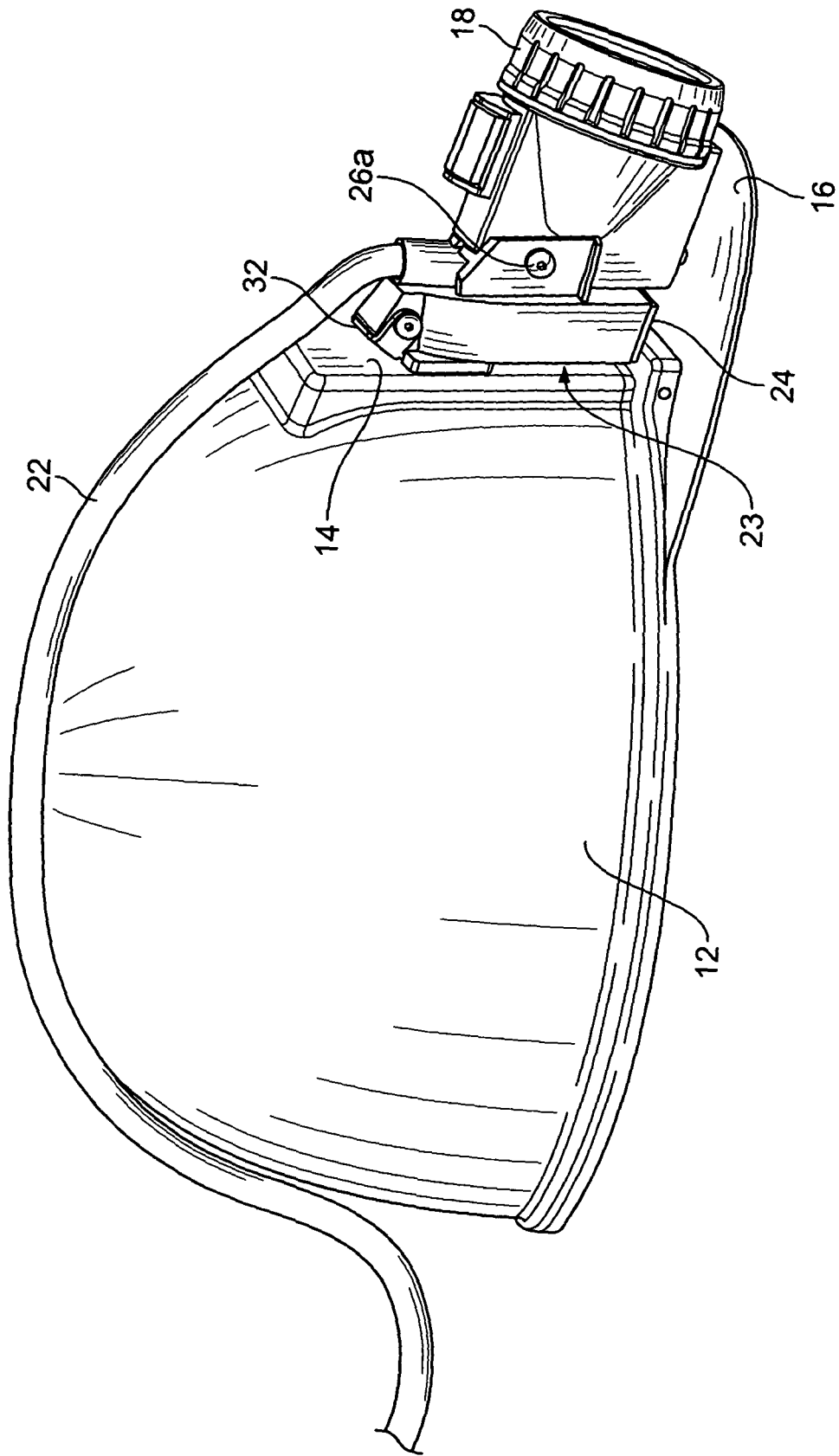

FIG. 1

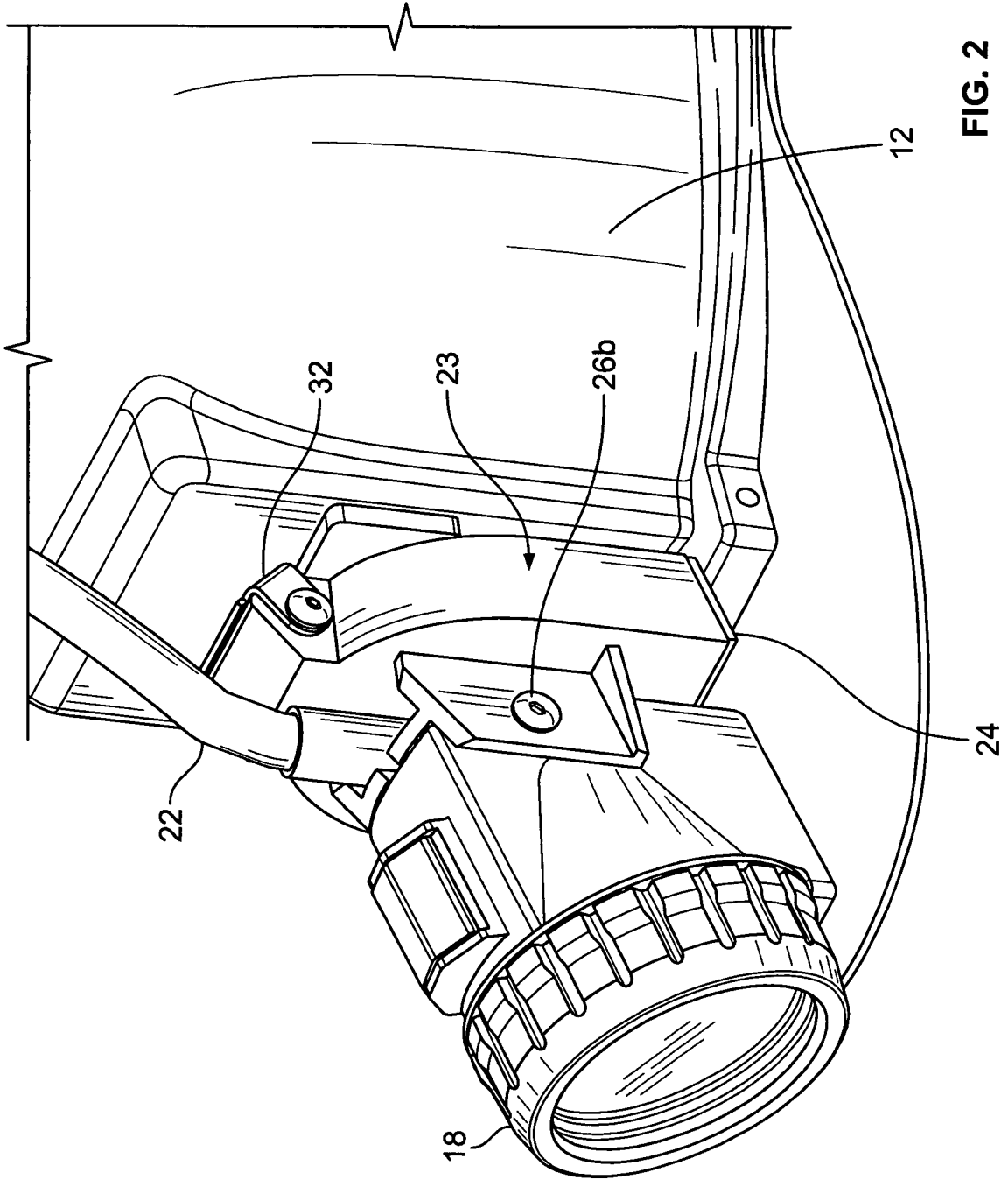

FIG. 2

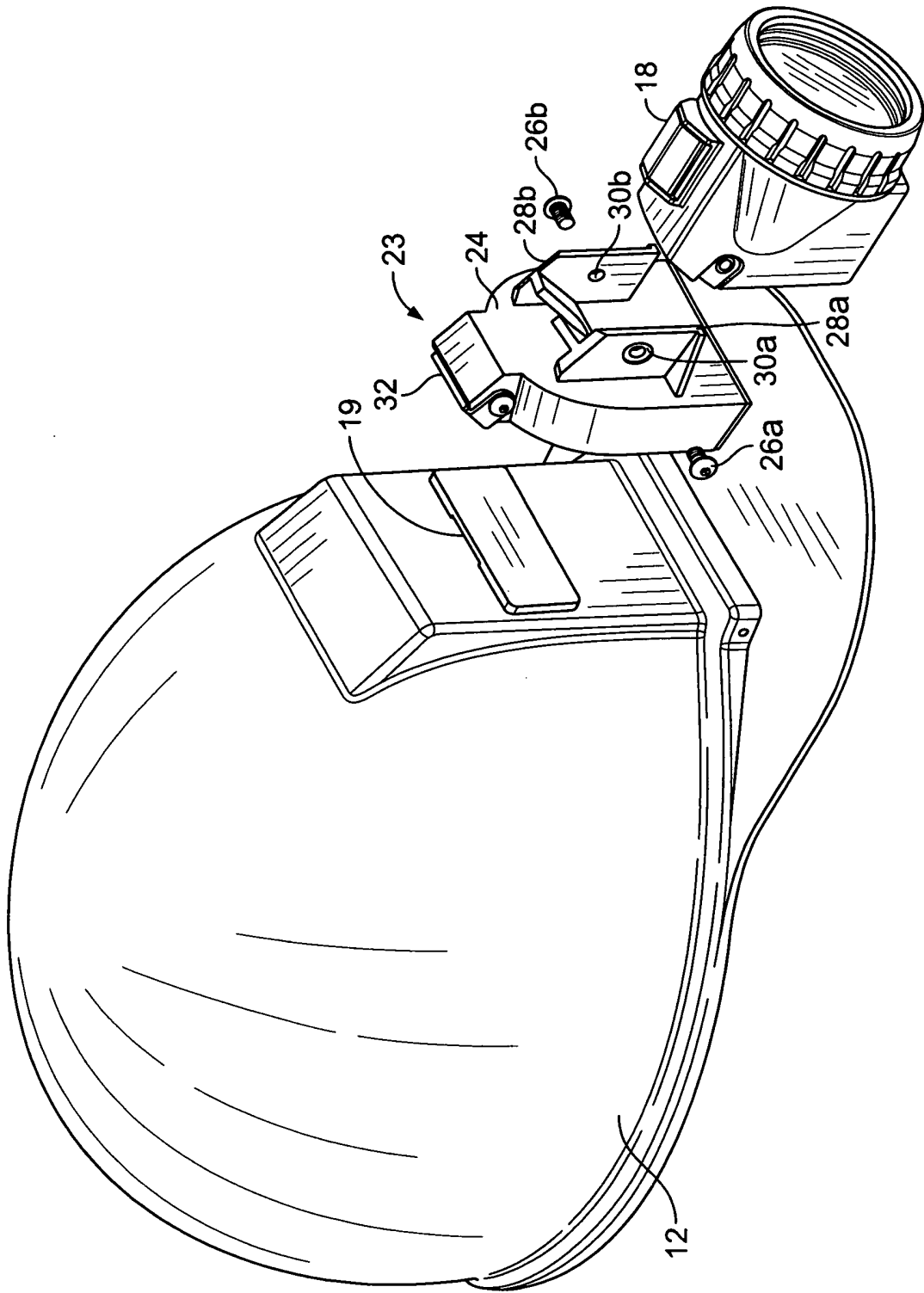

FIG. 3

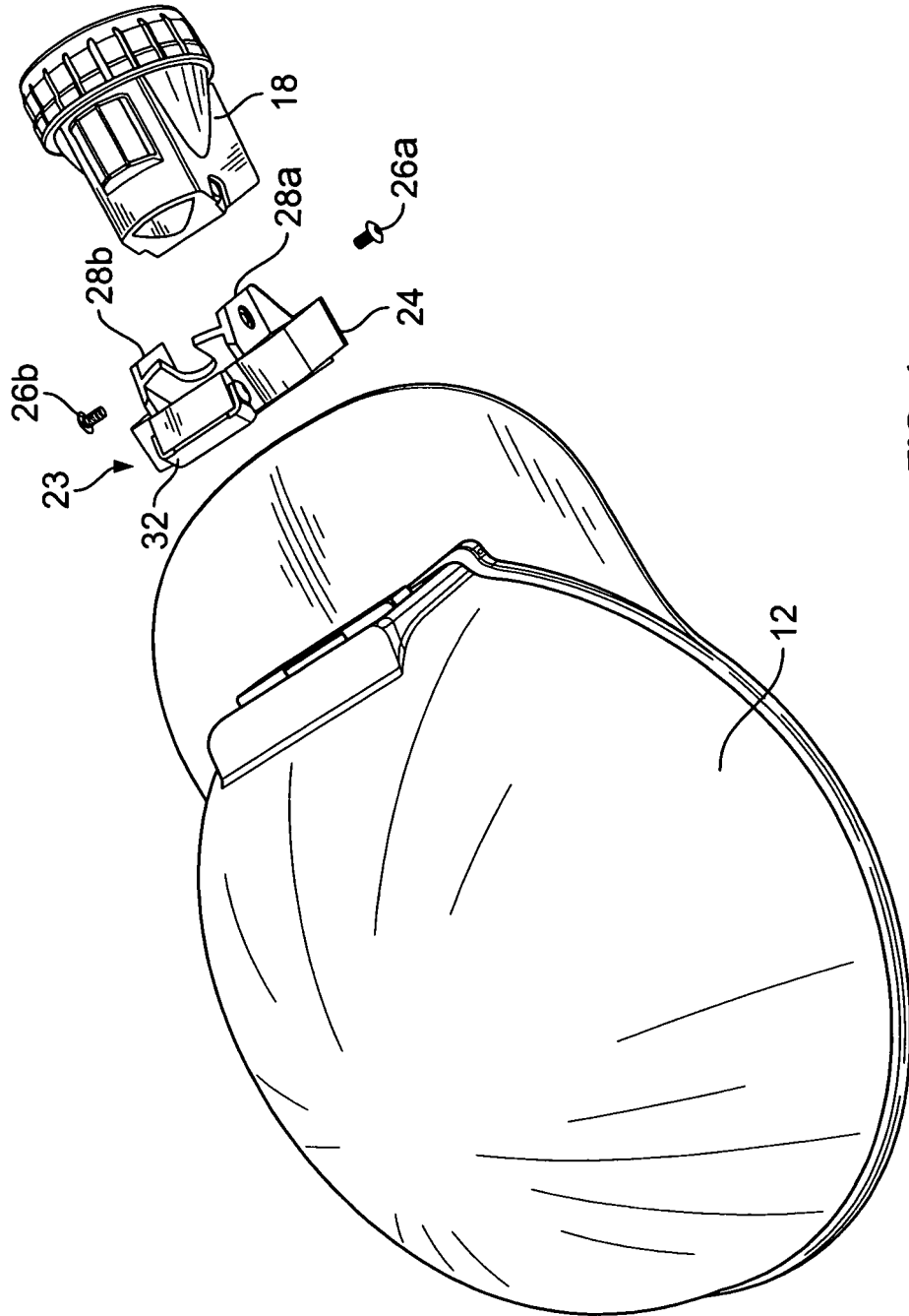

FIG. 4

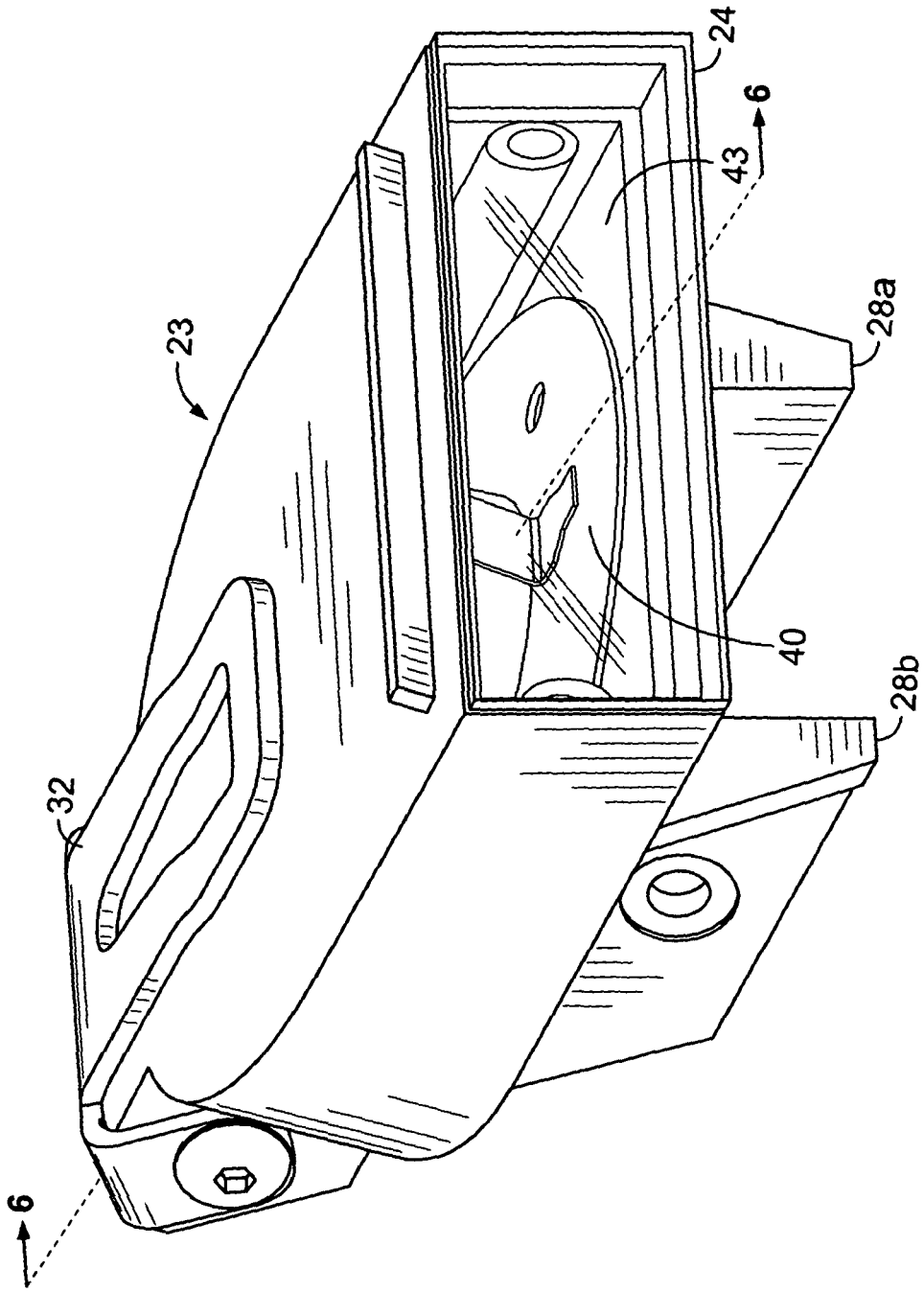

FIG. 5

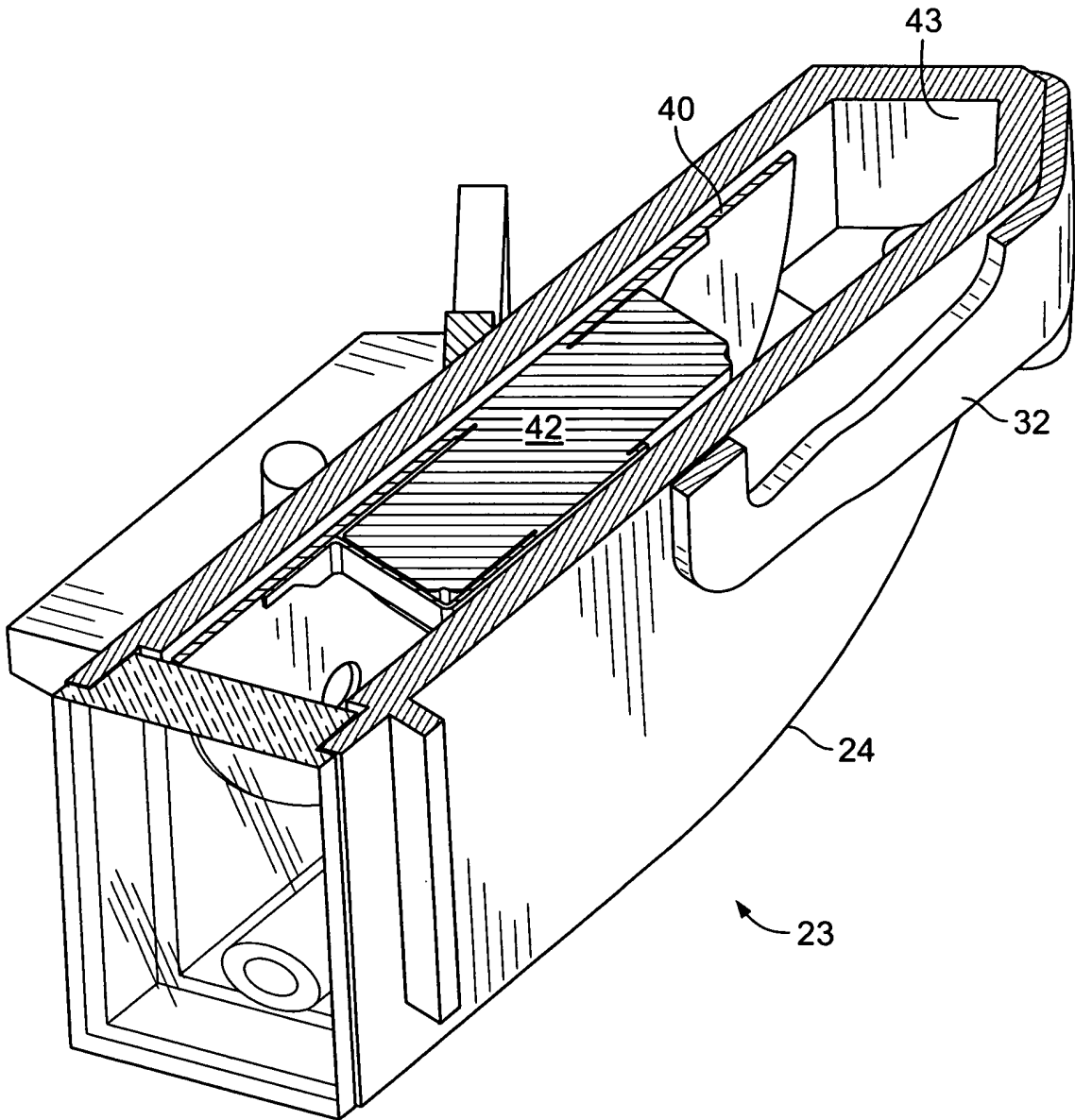

FIG. 6

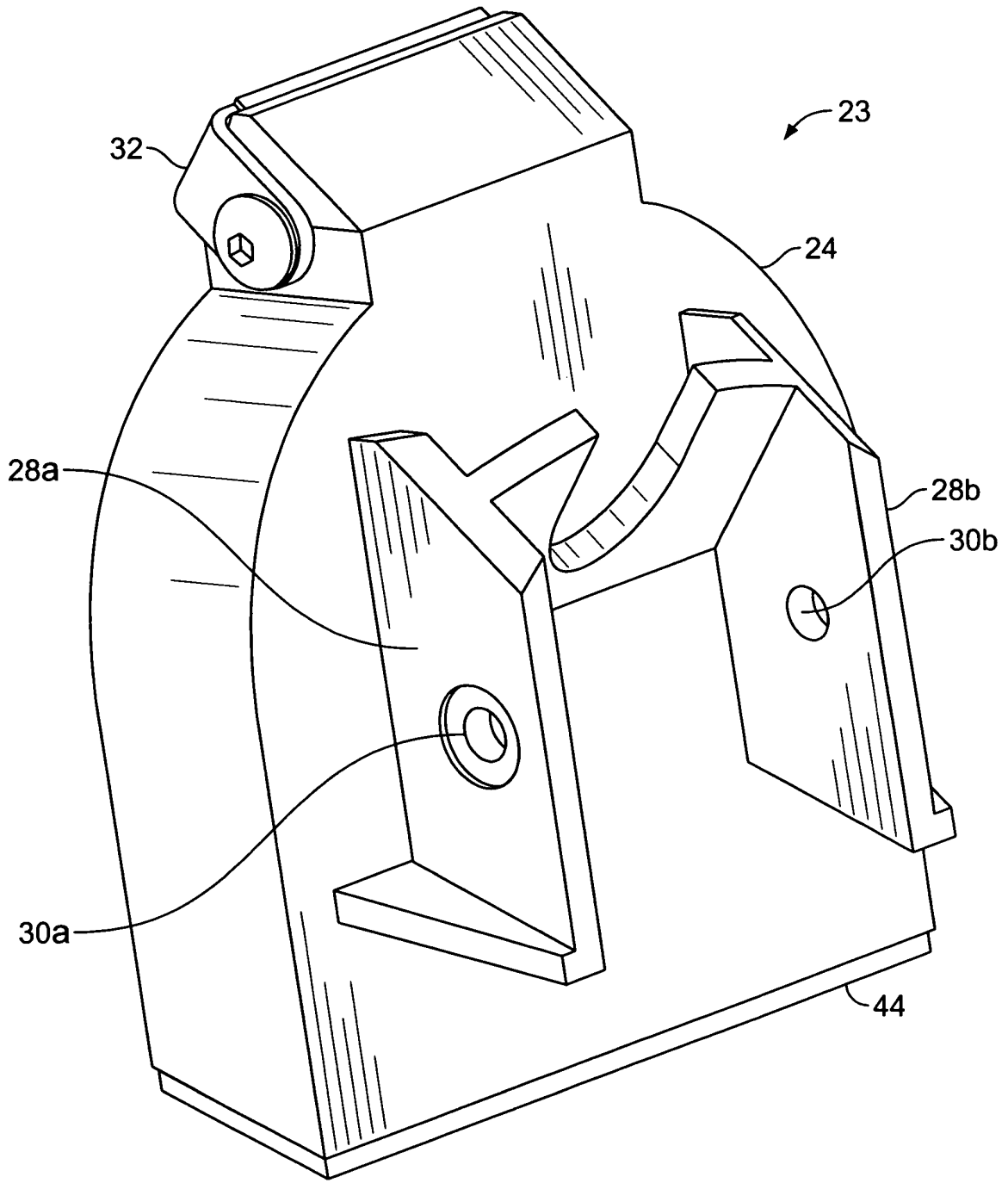

FIG. 7

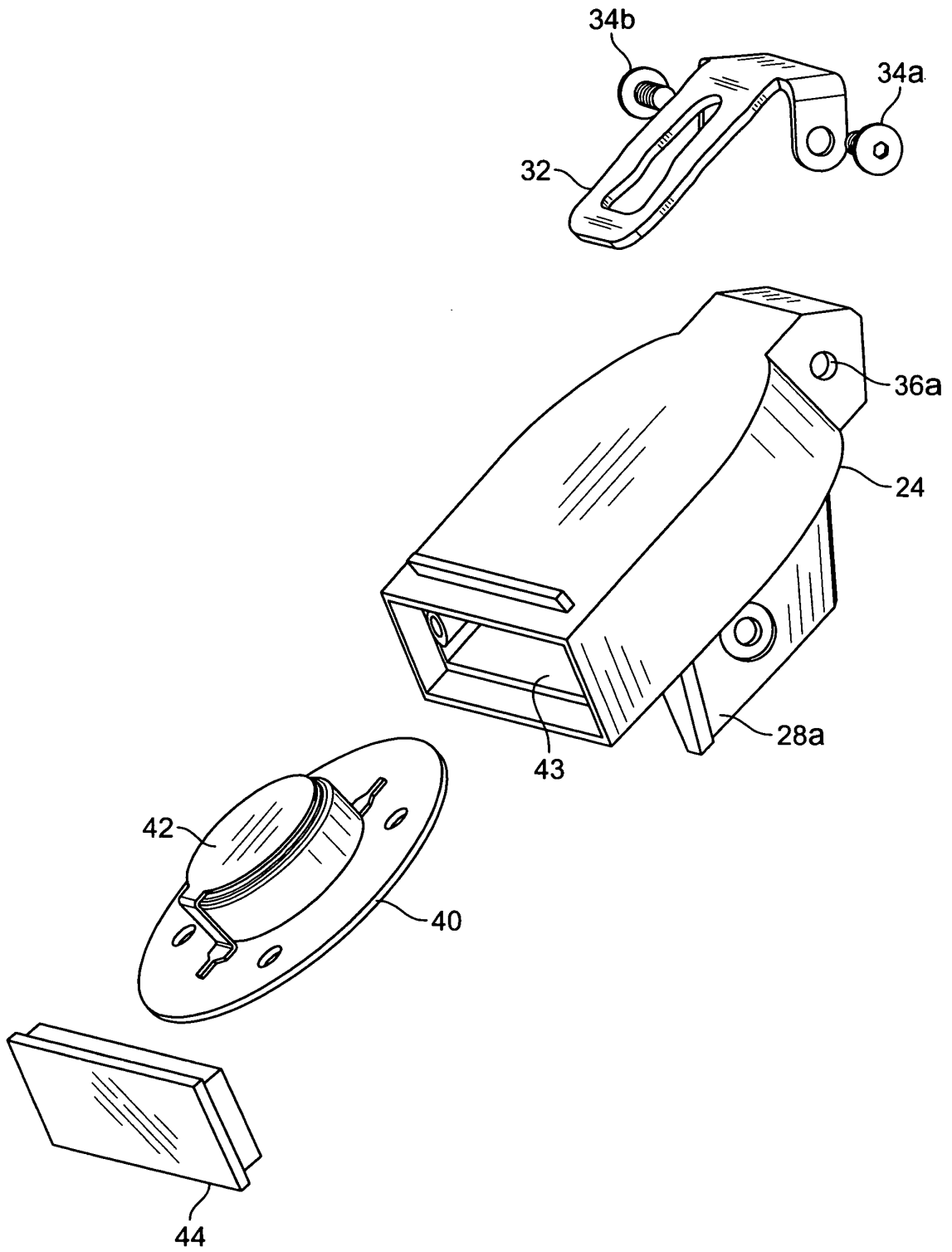

FIG. 8

REFERENCES CITED IN THE DESCRIPTION

This list of references cited by the applicant is for the reader's convenience only. It does not form part of the European patent document. Even though great care has been taken in compiling the references, errors or omissions cannot be excluded and the EPO disclaims all liability in this regard.

Patent documents cited in the description

- US 96162707 P [0001]