

10



Europäisches Patentamt
European Patent Office
Office européen des brevets

11 Publication number:

0 330 207
B1

12

EUROPEAN PATENT SPECIFICATION

45 Date of publication of patent specification: **06.02.91**

51 Int. Cl.⁵: **B 01 J 2/16, B 01 J 8/38**

21 Application number: **89103205.4**

22 Date of filing: **23.02.89**

54 **Fluidized bed dryer/granulator.**

30 Priority: **24.02.88 US 159805**

43 Date of publication of application:
30.08.89 Bulletin 89/35

46 Publication of the grant of the patent:
06.02.91 Bulletin 91/06

84 Designated Contracting States:
AT BE CH DE ES FR GB GR IT LI LU NL SE

56 References cited:
US-A-4 027 624
US-A-4 532 155

73 Proprietor: **WARNER-LAMBERT COMPANY**
201 Tabor Road
Morris Plains New Jersey 07950 (US)

72 Inventor: **Chaur-Ming, Jan**
3 Bedminister Road
Randolph New Jersey 07869 (US)
Inventor: **Oehling, Mark E.**
Rd. No. 1, Box 670A
Stroudsburg Pennsylvania 18301 (US)

74 Representative: **Mansmann, Ivo**
c/o Gödecke AG - Patentabteilung Postfach 569
Mooswaldallee 1-9
D-7800 Freiburg (DE)

Note: Within nine months from the publication of the mention of the grant of the European patent, any person may give notice to the European Patent Office of opposition to the European patent granted. Notice of opposition shall be filed in a written reasoned statement. It shall not be deemed to have been filed until the opposition fee has been paid. (Art. 99(1) European patent convention).

Description**Field of the invention**

This invention relates to fluidized bed apparatus for treating pulverulent material, and more particularly, to a fluidized bed dryer/granulator for applying a coating to pellets used in pharmaceutical preparations.

Description of the prior art:

In the production and/or treatment of various pulverulent or granular materials, including pharmaceutical preparations, fluidized bed apparatus is commonly used to promote coating, drying and/or granulation of the material. In some conventional apparatus, air or other gaseous medium is caused to flow through a chamber to form granules from a fluid introduced into the chamber, or to coat and/or dry pulverulent material already in the chamber. Examples of some prior art devices are shown in the following patents: US patent Nos. 3,443,621, 3,607,365, 3,716,020 and 3,828,729; British patent Nos. 1,212,074 and 1,517,104; and German Offenlegungsschrift 27 38 485.

Conventional fluidized bed apparatus for drying and/or coating granular material is either relatively complex and expensive in construction, expensive to operate, and/or has a very specialized use limited by fixed components of the apparatus.

Summary of the invention:

According to the invention, a fluidized bed chamber for containing material to be treated has an axial air inlet for directing a flow of air axially therethrough, and at least one removable air inlet is positioned in the chamber for directing a circumferential flow of air into the chamber to interact with the axial flow to produce an orbital or swirling motion, enhancing the rate of treatment of the material in the chamber. The apparatus is thus exceptionally simple and economical in construction and at the same time achieves an economy of operation not obtained in most prior art devices.

Brief description of the drawings:

The foregoing and additional objects and advantages of the invention will become apparent from the following detailed description and appended claims taken in conjunction with the drawings, wherein like reference characters designate like parts throughout the several views and wherein:

Fig. 1 is a top plan view of the apparatus of the invention;

Fig. 2 is a vertical sectional view taken along line 2—2 in figure 1;

Fig. 3 is a transverse sectional view taken along line 3—3 in figure 2; and

Fig. 4 is an enlarged perspective view of one of the removable air inlets which are positioned in the chamber of the dryer/granulator.

Description of the preferred embodiments:

Referring more particularly to the drawings, the fluidized bed dryer/granulator according to the invention is indicated generally at 10 in the drawings and comprises a housing having a cylindrical chamber 11 with a top wall 12 having a plurality of filtered outlets 13 distributed thereover. The filtered outlets may comprise, for example, suitable frames (not shown) with cloth filter bags 14 secured thereover. A number of inlet nozzles 15 are also uniformly distributed over the top wall 12 for spraying a desired coating material into the chamber. For example, the material might be any water-soluble polymer, sustained release coating for pellets used in the manufacture of pharmaceutical capsules.

A frustoconically shaped bowl 16 at the bottom of the chamber has an inwardly tapered wall 17 terminating at its lower end in a perforated bottom wall 18. An axial air inlet 19 is connected to the bottom of the chamber for effecting an axially upward flow of air through the perforated bottom wall 18 and thence upwardly through the bowl and chamber and outwardly through the filtered outlets 13.

A pair of diametrically opposed, perforated, removable, lateral or circumferential air inlet housings 20 and 21 are supported in the bottom of the bowl 16 on perforated bottom wall 18 and side wall 17. Each air inlet housing 20 and 21 has a curved front wall 22, a back wall 23, bottom wall 24, and opposite side walls 25 and 26. One of the side walls 25 in each removable air inlet housing is perforated as at 27. An air inlet 28 is connected with the interior of the housing 20 through non-perforate wall 26, and an air inlet 29 is connected with the interior of the housing 21 through non-perforate wall 26. It should be noted that the perforated side walls 25 in the air inlet housings face in the same circumferential direction, i.e., either clockwise or counterclockwise (clockwise as shown in figure 3). Consequently, the streams of air flowing from the axial air inlet 19 and the circumferential air inlets 20 and 21 interact to cause an orbital or swirling motion to the air flowing through the bowl and chamber, as shown by the arrows "A" in figure 2.

In use, a quantity of granular material, such as pellets "P" for use in making filled medicinal capsules, is placed in the chamber as shown in figure 2 and air is caused to flow through the axial inlet 19 and circumferential inlets 20 and 21, thereby producing an orbital motion in the pellets. A suitable coating material may then be introduced into the chamber via nozzles 15 for coating the pellets. The motion of the pellets in the chamber insures maximum coverage of the pellets in a minimum amount of time. In fact, an increase in the rate of coating of fifteen to twenty times the normal rate has been observed.

The air inlet housing 20 and 21 simply rest in the bowl and can be lifted out, if desired, to return the apparatus to normal configuration so that it can be used for other purposes.

The size of the perforations in the side walls 25

of air inlet housings 20 and 21 may be varied by simply replacing that wall, as desired, to obtain an opening size compatible with the size of the pellets being treated.

Although the invention has been described with reference to a particular embodiment, it is to be understood that this embodiment is merely illustrative of the application of the principles of the invention. Numerous modifications may be made therein and other arrangements may be devised without departing from the spirit and scope of the invention.

Claims

1. A fluidized bed apparatus, comprising:
a housing (10) having a top wall (12), a side wall (11) and a bottom wall (18);

an axial air inlet (19) communicating with the interior of the housing for directing an axial flow of air through the housing; and

at least one lateral air inlet (20, 21) communicating with the interior of the housing characterized by air inlets (20, 21) which are removably supported on the perforated bottom wall (18) and the inwardly tapering position (17) and have perforated side walls facing in the same circumferential direction, directing a lateral flow of air to produce a swirling or orbital motion.

2. A fluidized bed apparatus as claimed in claim 4, wherein:

the axial air inlet extends through the bottom wall (18);

and a plurality of filtered air outlets (13) are in the top wall (12).

3. A fluidized bed apparatus as claimed in claim 2, wherein:

at least one spray nozzle (15) extends through the top wall (12) for directing a spray of material into the housing.

4. A process for drying, coating and/or granulating a quantity of granule material in a vertical air stream caused to flow axially upwards from the bottom of a cylindrical chamber, characterized in that a second substantially horizontal air stream is blown peripherally and laterally into the chamber by means of a plurality of lateral or circumferential air inlets characterized by perforated side-walls facing in the same circumferential direction and being positioned in the lower part of said chamber, thereby producing an additional concentric vector of an orbital or swirling motion of the granular material around the vertical axis of said chamber.

Patentansprüche

1. Wirbelschichtgerät, welches ein Gehäuse (10) mit einer oberen Wandung (12), einer seitlichen Wandung (11) und einem Boden (18); einen in axialer Richtung angeordneten Lufteinlass (19), der mit dem Innenraum des Gehäuses in Verbindung steht, um einen Luftstrom in axialer Richtung durch das Gehäuse zu lenken; und wenigstens eine seitliche Luftzuführung (20, 21), die mit

dem Innenraum des Gehäuses in Verbindung steht, aufweist, gekennzeichnet durch Luftzuführungen (20, 21), die auf dem perforierten Boden (18) und dem sich nach innen verjüngenden Bereich (17) auswechselbar gelagert sind und perforierte seitliche Wandung aufweisen, die in der Richtung entlang der durch den Umfang bestimmten Kreisbahn ausgerichtet sind, derart, dass ein seitlicher Luftstrom so gelenkt wird, dass er eine Durchwirbelung oder eine Bewegung entlang einer Kreisbahn erzeugt.

2. Wirbelschichtgerät nach Anspruch 1, dadurch gekennzeichnet, dass der in axialer Richtung angeordnete Lufteinlass sich durch den Boden (18) erstreckt und dass in der oberen Wandung (12) eine Vielzahl von mit Filtern ausgestatteten Luftaustrittsöffnungen (13) angeordnet sind.

3. Wirbelschichtgerät nach Anspruch 2, dadurch gekennzeichnet, dass sich durch die obere Wandung (12) wenigstens eine Einspritzdüse (15) erstreckt, die dazu bestimmt ist, einen Materialstrahl in den Innenraum des Gehäuses einzuführen.

4. Verfahren zum Trocknen, Beschichten und/oder Granulieren einer Menge körnigen Materials in einem senkrechten Luftstrom, der vom Boden einer zylindrischen Kammer in axialer Richtung nach oben gelenkt wird, dadurch gekennzeichnet, dass ein zweiter, im wesentlichen horizontaler Luftstrom vom Umfang her oder seitlich mittels einer Vielzahl von seitlichen oder am Umfang angeordneten Luftzuführungen in die Kammer eingeblasen wird, wobei diese Luftzuführungen perforierte Seitenwände aufweisen, die entlang einer durch den Gehäuseumfang bestimmten Kreisbahn ausgerichtet und im unteren Teil der Kammer angeordnet sind, wodurch ein zusätzlicher konzentrischer Vektor einer kreisförmigen Bewegung oder Wirbelbewegung des körnigen Materials um die senkrechte Achse der Kammer erzeugt wird.

Revendications

1. Un appareil à lit fluidisé, comprenant:

—un carter (10) équipé d'une paroi supérieure (12), d'une paroi latérale (11) et d'une paroi inférieure (18);

—une voie d'entrée d'air axiale (19) communiquant avec l'intérieur du carter pour diriger un courant d'air axial à travers le carter; et

—au moins une voie d'entrée d'air latérale (20, 21) communiquant avec l'intérieur du carter, caractérisé par des voies d'entrées d'air (20, 21) qui sont fixées et, démontables, sur la paroi perforée inférieure (18) et sur la partie conique vers l'intérieur (17) et qui présente des parois latérales perforées tournées dans la même direction circonférentielle, dirigeant un courant d'air latéral pour produire un tourbillon ou un mouvement orbital.

2. Un appareil à lit fluidisé selon la revendication 1, dans lequel la voie d'entrée d'air axiale s'étend à travers la paroi inférieure (18); et une

pluralité de sorties d'air avec filtres (13) est située dans la paroi supérieure (12).

3. Un appareil à lit fluidisé selon la revendication 2, dans lequel au moins une buse d'arrosage ou d'atomisation (15) traverse la paroi supérieure (12) afin d'arroser ou atomiser un jet dirigé de matériau dans le carter.

4. Un procédé pour sécher, revêtir et/ou mettre en grains une certaine quantité de matériau en graines dans un courant d'air vertical se déplaçant vers le haut axialement, en partant du fond d'une chambre cylindrique, caractérisé en ce

qu'un second courant d'air, sensiblement horizontal, est insufflé périphériquement et latéralement dans la chambre d'air au moyen d'une pluralité de voies d'entrées d'air latérales ou circonférentielles, caractérisées par des parois latérales perforées tournées dans la même direction circonférentielle et positionnées dans le bas de ladite chambre, de manière à réaliser une composante vectorielle concentrique additionnelle à un déplacement orbital ou tourbillonnaire du matériau en grains, autour de l'axe vertical de ladite chambre.

15

20

25

30

35

40

45

50

55

60

65

4

FIG. 1

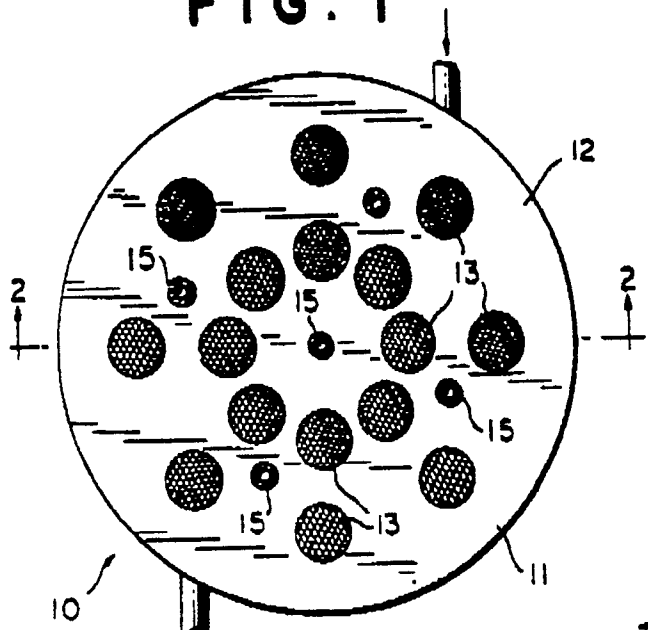

FIG. 4

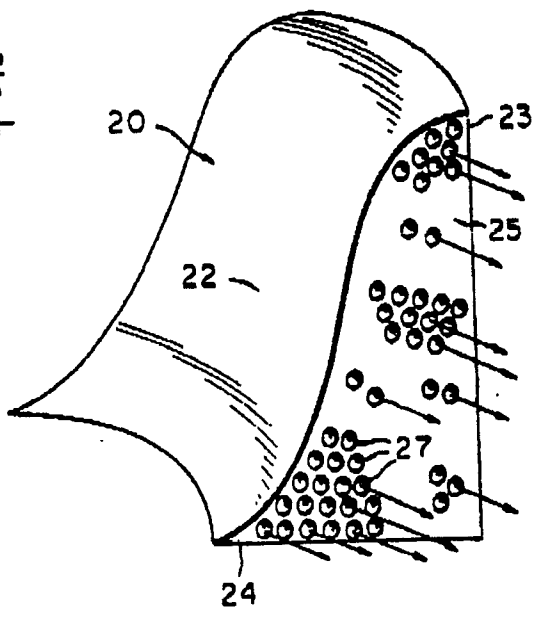

FIG. 2

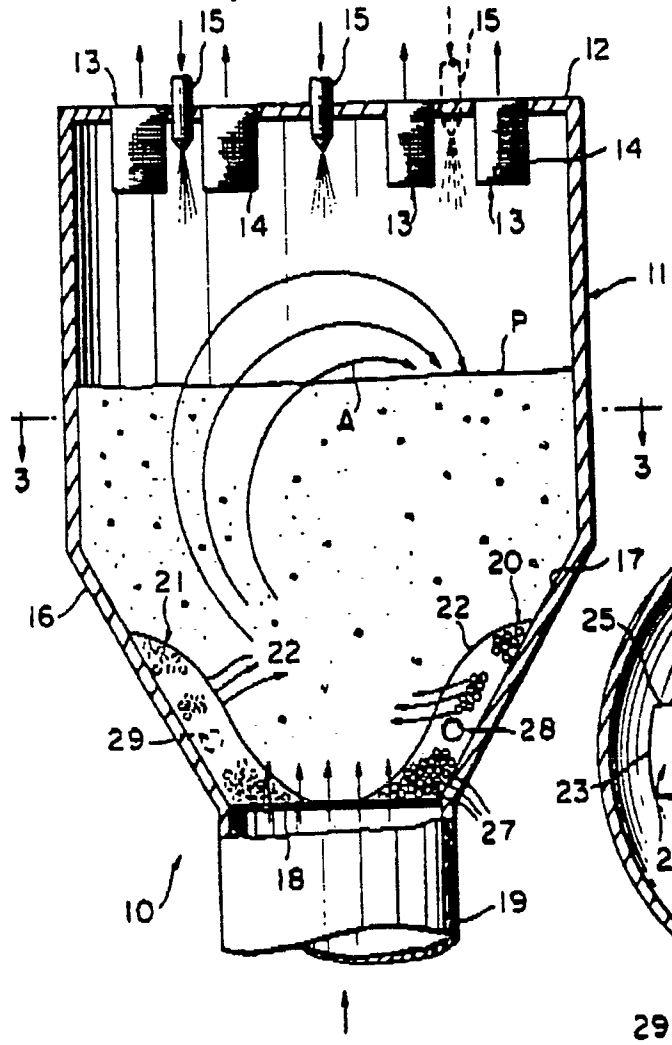

FIG. 3

