

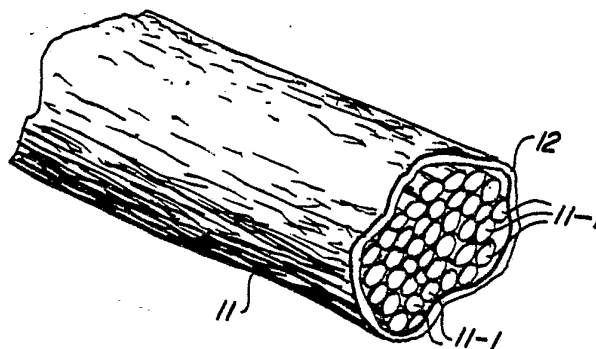

INTERNATIONAL APPLICATION PUBLISHED UNDER THE PATENT COOPERATION TREATY (PCT)

<p>(51) International Patent Classification³ : A61F 1/00, 5/04</p>	<p>A1</p>	<p>(11) International Publication Number: WO 85/ 00511 (43) International Publication Date: 14 February 1985 (14.02.85)</p>
<p>(21) International Application Number: PCT/US84/01186 (22) International Filing Date: 24 July 1984 (24.07.84) (31) Priority Application Number: 517,020 (32) Priority Date: 25 July 1983 (25.07.83) (33) Priority Country: US (71)(72) Applicant and Inventor: MEDLEN, John, C. [US/US]; 2002 East River Road K17, Tucson, AZ 85718 (US). (74) Agents: HOFFMAN, Charles, R. et al.; Cahill, Sutton & Thomas, 1400 Valley Bank Center, Phoenix, AZ 85073 (US). (81) Designated States: AT (European patent), DE (European patent), FR (European patent), GB (European patent), JP, SE (European patent).</p>		<p>Published <i>With international search report.</i></p>

(54) Title: COLLAGEN LIGAMENT AND TENDON REGENERATION METHOD AND MATERIAL



(57) Abstract

A skin collagen or a structural collagen (11) is treated with glutaraldehyde to achieve cross linking (30) of the protein strands which constitute the collagen. The collagen is provided in the form of a suitable weave with sufficient space between its strands or fibers to function as a 'scaffold' through which ligament fibroblasts can propagate. A sheet (16) of the collagen is rolled into a coil-shaped configuration which is positioned between ends of a torn anterior cruciate ligament. The ends (20) of the collagen coil are sutured to the torn ends of the ligament. The joint is immobilized, during which time the synovial sheath regrows and protects the ligament from synovial fluid. The fibroblasts grow through the collagen, completely healing in as little as three weeks. In one embodiment of the invention, one end of the collagen is inserted in a carved out portion of the bone and is peripherally stitched to its periosteum. The regenerating ligament forms a normal attachment to the bone.

FOR THE PURPOSES OF INFORMATION ONLY

Codes used to identify States party to the PCT on the front pages of pamphlets publishing international applications under the PCT.

AT	Austria	KR	Republic of Korea
AU	Australia	LI	Liechtenstein
BE	Belgium	LK	Sri Lanka
BG	Bulgaria	LU	Luxembourg
BR	Brazil	MC	Monaco
CF	Central African Republic	MG	Madagascar
CG	Congo	MR	Mauritania
CH	Switzerland	MW	Malawi
CM	Cameroon	NL	Netherlands
DE	Germany, Federal Republic of	NO	Norway
DK	Denmark	RO	Romania
FI	Finland	SD	Sudan
FR	France	SE	Sweden
GA	Gabon	SN	Senegal
GB	United Kingdom	SU	Soviet Union
HU	Hungary	TD	Chad
JP	Japan	TG	Togo
KP	Democratic People's Republic of Korea	US	United States of America

COLLAGEN LIGAMENT AND TENDON REGENERATION METHOD AND
MATERIAL

Background of the Invention

5

The invention relates to methods and materials for repairing ligaments and tendons, and more particularly to methods using collagen material to repair anterior cruciate ligaments without causing inflammation and avoiding digestion of ligament tissue by synovial fluid.

10

In animal knee structures and human knee structures, large ligaments called cruciate ligaments prevent knee joints from translating in opposite directions during movement, especially twisting or pivoting movement. The anterior cruciate ligament is the one that is most often torn in athletes. When this happens, it usually ends an athlete's career, because up to now, no adequate way of repairing or replacing the anterior cruciate has been devised. A ligament is composed of a number of bundles of collagen fibers, the collagens consisting of complex protein molecules, including strings of amino acids. Ligaments and tendons are composed of different kinds of collagens, ligaments having the property that they have very high tensile strength and are very unyielding, whereas tendons stretch more and have more shock absorbing characteristics. In the knee, the anterior cruciate ligaments are covered by synovial sheaths which protect the ligaments from synovial fluid which lubricates the knee joints to reduce friction between the surface of the bones forming the joint. Synovial fluid has the property that it digests ligament material. The anterior cruciate ligament is exposed

20

25

30

35

SUBSTITUTE SHEET



to synovial fluid if it is torn, and it is this problem that has prevented successful repair of ligaments by simply suturing the torn ligament together. Torn ligaments in the knee which are not exposed to synovial fluid, such as posterior cruciate ligaments, are frequently successfully repaired by simply suturing the torn ends together. But up to now, anterior cruciate ligaments have never been successfully repaired because it has not been possible to reconstitute the synovial sheath of a torn anterior cruciate ligament or otherwise protect ligament tissue from digestion by synovial fluid. In the past, it has been attempted to take fatty tissue and wrap it around a torn anterior cruciate ligament, after suturing it to protect it from synovial fluid. This expedient has failed, and the ligament has dissolved. Approximately, twenty-five years ago, surgeons began taking tendon tissue, for example, fascia lata tissue from a tough band of tendon near the thigh, and weaving that into the knee, drilling a hole through a portion of the bone forming the joint, tunneling the fascia lata tissue through the drilled hole, and stapling it to the bone. Initially, this technique works well in that it stabilizes the knee joint. However, the fascia lata tendon tissue gradually stretches, and inevitably fails. Numerous operations have been devised to replace such repairs after they fail or to tighten up the tissue that has been used to replace a torn ligament. More recently, due to the failure of natural collagen materials as ligament replacements for the anterior cruciate ligament, synthetic substitutes have been tried. For example, a synthetic ligament referred to as a Jenkins ligament, has been made in Great Britain beginning in about 1976. This ligament consists of a carbon fiber material which is

SUBSTITUTE SHEET



perhaps one-half a millimeter in diameter. Bundles of these fibers are woven together to make the Jenkins ligament, which is then attached to the bone of a knee joint using the above-mentioned drilling technique, tunneling of the fibers through the drilled hole, and stapling a remote end of the substitute ligament to the bone on the other end of the hole. This technique provides a ligament replacement which is initially very strong and provides a high degree of initial stabilization of the joint. Unfortunately, after approximately 10,000 cycles of stressing, or typically twelve to eighteen months, the fibers usually begin to crack. This results in small carbon particles breaking loose and being present in the joint, causing serious inflammatory reactions that lead to arthritis. The inflammation, of course, usually cuts down in joint movement and mobility, preventing the patient from doing exercises that are necessary to keep the muscles from atrophying. Attempts have been made to coat the Jenkins ligament with inert material, such as polyglycolic acid have failed, although they extend the life of the Jenkins ligament approximately six months.

Other collagens than the above-mentioned fascia lata have been experimentally used for ligament repair or replacement, but up to now, all of them have failed in useful repairing the anterior cruciate ligament or any other ligament that is exposed to synovial fluid. One reason for the universal failure of such collagens is that they are all antigenic and simulate severe inflammatory reactions. Furthermore, none has displayed the enduring strength that it would be necessary to permanently stabilize a knee joint.

SUBSTITUTE SHEET



It is clear that there is a great need for development of any method that will permanently and satisfactorily stabilize a joint of an individual whose anterior cruciate ligament (or any other ligament that is exposed to synovial fluid) has been torn, especially among high salaried professional athletes whose careers are ended by the tearing of an anterior cruciate ligament.

Accordingly, it is a primary object of the invention to provide an improved method and material for repairing torn anterior cruciate ligaments and other ligaments that are exposed to synovial fluid.

It is another object of the invention to provide an improved method and material which allows ligament material, especially in portions of a joint wherein synovial fluid is present, or tendon material to regenerate itself.

It is another object of the invention to provide an improved method and collagen material which is not antigenic and which does not produce severe inflammatory reactions in a joint, a ligament of which is being repaired.

It is another object of the invention to provide a collagen method and material which allows regrowth or reconstitution of the synovial sheath of a torn anterior cruciate ligament, or other torn ligament exposed to synovial fluid.

It is another object of the invention to provide a method and material for repair of a torn ligament

SUBSTITUTE SHEET



which minimizes the amount of time that immobilization of the joint is required.

5 It is another object of the invention to provide a method and material for repairing ligaments which avoids the need for immobilizing the joint to allow immediate exercise of the joint tissues.

10 It is another object of the invention to provide a method and material which provides a non-antigenic "scaffolding" of proper density to allow ligament material or tendon material in an animal or human to regenerate itself by growing and propagating through the scaffolding without being digested by synovial
15 fluid.

It is another object of the invention to provide a "scaffolding" substance which is sufficiently non-antigenic to permit regrowth of the synovial sheath
20 of a ligament in a joint.

Summary of the Invention

25 Briefly described, and in accordance with one embodiment thereof, the invention provides a method for treating a skin collagen or a structural collagen of proper density to allow it to function as a scaffolding through which ligament or tendon fibroblasts can propagate, which method achieves a sufficiently high
30 degree of cross-linking of the collagen, avoiding antigenicity of the collagen sufficiently to allow regrowth of a torn synovial sheath of the ligament, by treating the collagen with glutaraldehyde or other similar cross-linking agent that does not leave unbound
35 side radicals that cause inflammation. In the described

SUBSTITUTE SHEET

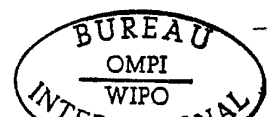

embodiment of the invention, bovine skin collagen, "woven" to produce the needed density, is cross-linked by glutaraldehyde. This collagen is rolled up as a small coil from a small sheet of the
5 glutaraldehyde-treated collagen material. The diameter and length of the collagen coil is selected so that it can be positioned between ends of the torn ligament to be repaired. DEXON or PROLENE sutures are provided in a close stitching pattern
10 to attach each end of the collagen coil to the respective torn ends of the ligament. In one described embodiment of the invention, as one end of the collagen coil is situated in a drilled out portion of the bone of one member of the knee joint,
15 and peripheral portions of the collagen coil at the level of the surface of that bone member of the joint are peripherally stitched to the periosteum. The coiled configuration of the collagen material provides greatly increased surface area which increases
20 structural strength, avoids the weakness due to friability of the collagen material when it becomes wet, and improves the function of the collagen as a scaffold through which ligament fibroblasts can propagate and regenerate themselves. Experiments upon
25 dogs and histologic analyses of attempted ligament repairs at different stages of healing have shown that fibroblasts of the torn end of the ligament propagate through the scaffolding structure provided by the woven glutaraldehyde treated bovine skin
30 collagen to form a completely normal appearing regenerated anterior cruciate ligament in only approximately three weeks. In cases where the connection of the ligament to bone is torn, it has been found that if the bone is drilled into the

SUBSTITUTE SHEET

cancellous portion of the bone, actual ligament
fibroblasts grow out of the bone into woven,
glutaraldehyde-treated bovine skin collagen implanted
in the drilled hole and completely regenerate the
5 ligament. Drilled portions of the bone also become
regenerated to a normal level and a normal calcified
bone-ligament interface also is regenerated.
Histologic analysis of the regenerated joints shows that
the synovial sheath also regrown around the regenerated
10 ligament. After six weeks, the implanted collagen
mesh has essentially completely dissolved and
disappeared, and healthy regenerated ligament tissue
is present in its place. The regeneration of the
synovial sheath is believed to be due to the non-
15 antigenic character of the glutaraldehyde treated, woven
bovine skin collagen. The structural strength of
the glutaraldehyde treated skin collagen has been made
sufficiently strong to not only provide a scaffolding
structure through which the torn ligament may
20 regenerate, but also allows early de-immobilization
of the joint allowing early therapy and avoiding
atrophy of the regenerated ligament, cartilage,
ligament, and muscle tissue. The technique can
also be utilized to allow regeneration of tendon tissue.

25

Brief Description of the Drawings

Fig. 1 is a section view diagram illustrating a
portion of a knee joint, including the cruciate
30 ligaments thereof.

Fig. 1A is a section diagram similar to Fig. 1,
illustrating a torn anterior cruciate ligament.

SUBSTITUTE SHEET



Fig. 1B is a cross section of a typical anterior cruciate ligament.

5 Fig. 1C is an enlarged view illustrating the torn end portion of a torn ligament and the torn synovial sheath around it.

10 Fig. 2A is a schematic magnified diagram showing the basic structure of the woven, treated skin collagen used in accordance with the ligament repair method of the present invention.

15 Fig. 3 is a partial perspective view of the scaffolding structure formed by a structural collagen, such as rodent tail collagen.

Fig. 4 is a diagram illustrating generalized cross-linking of collagen strands.

20 Fig. 5 is a perspective view of a coiled configuration of collagen utilized in repair of a torn anterior cruciate ligament in accordance with the present invention.

25 Fig. 6 is a section diagram illustrating attachment of a coil collagen configuration to a bone in accordance with the present invention.

30 Fig. 7 illustrates an alternate technique for attachment of the collagen of the present invention to the torn bone of a joint using a drill and staple technique.

Fig. 8A is a section view diagram illustrating

SUBSTITUTE SHEET



use of the coiled collagen mesh of the present invention sutured to repair a partial defect in a ligament.

5 Fig. 8B is a section diagram illustrating use of the glutaraldehyde treated woven bovine skin collagen mech of the present invention sutured between frayed ends of a completely torn ligament.

10 Fig. 9 is a section view diagram illustrating a completely regenerated anterior cruciate ligament and a regenerated interface thereof with femur and tibia bone portions of a knee joint, and also illustrating a regenerated synovial sheath surround-
15 ing the regenerated anterior cruciate ligament.

 Fig. 10 is a photoprint of a dog's knee six weeks after an anterior cruciate ligament had been totally removed, showing a completely regenerated,
20 healthy anterior ligament that, in accordance with the present invention, regrew and replaced the original ligament.

 Fig. 11 is a print of a photomicrograph showing
25 the results of histologic analysis of a regenerated ligament and synovial sheath produced in accordance with the present invention in the anterior cruciate ligament of a dog's knee.

30 Fig. 12 is a print of a photomicrograph of a biopsy showing both original, natural anterior cruciate ligament material and ligament material regenerated in accordance with the present invention and a transition zone therebetween in a dog six weeks after

SUBSTITUTE SHEET



implantation of the collagen mesh to repair that ligament in accordance with the invention.

5 Fig. 13 is a print of a photograph showing an anterior cruciate ligament/bone interface after twelve weeks in a dog's knee in which the entire original anterior cruciate ligament had been removed and replaced by the collagen mesh of the present invention.

10

Fig. 14 is a print of a photomicrograph showing an abrupt transition between normal ligament tissue and MARLEX mesh implanted to repair a human anterior cruciate ligament.

15

Fig. 15 is a print of a photomicrograph showing an abrupt transition between normal anterior ligament tissue and DEXON mesh used to repair a human anterior cruciate ligament.

20

Fig. 16 is a print of a photomicrograph illustrating rupturing of an inflammation due to carbon fiber mesh used to replace an anterior cruciate ligament in a human knee.

25

Fig. 17 is a print of a photomicrograph illustrating the transition between normal ligament tissue which is not exposed to synovial fluid and has been repaired by the prior art technique of suturing or stapling torn ends together.

30

Fig. 18 is a print similar to Fig. 17 showing different features thereof.

SUBSTITUTE SHEET



Description of the Invention

Referring now to Fig. 1, knee joint 1 includes an upper bone 2, called the femur and a lower bone 3, called the tibia. The enlarged end of femur 2 is covered by a layer of cartilage 4 which interfaces with a layer of cartilage 5 that is disposed upon the upper end of tibia 3. Reference numeral 6 designates the knee cap on the front end of the knee and tendons attached thereto. Reference numeral 8 generally designates the cruciate ligaments, which together have the general shape of a cross. Their upper ends are attached to the surfaces of femur 2 and their lower ends are attached to the surface of tibia 3. Cruciate ligaments 8 prevent lateral translation of the surface of femur 2 in the direction of arrow 9 relative to tibia 3, and also prevent twisting of tibia 3 relative to femur 2. Reference numeral 11 designates the anterior cruciate ligament, the other ligament shown being the posterior cruciate ligament.

It is important to note that the knee is surrounded by a sac which keeps synovial fluid in the vicinity of the knee, and within that sac is the anterior cruciate ligament 11, including a synovial sheath surrounding anterior cruciate ligament fiber bundles from being digested by synovial fluid.

Often, tears of the anterior cruciate ligament 11 occur in the mid portion thereof, as indicated by reference numeral 11A in Fig. 1A. Both the ligament tissue and the synovial sheath surrounding the anterior cruciate ligament are completely torn.

SUBSTITUTE SHEET

Referring now to Fig. 1B, a cross section diagram is shown of anterior cruciate ligament 11, which includes a plurality of densely packed bundles 11A of ligament collagen fibers. Reference numeral 5 12 designates the synovial sheath which is disposed about ligament material 11A to protect it from being digested by the above-mentioned synovial fluid.

10 In accordance with the present invention, it was necessary to attempt to find a way of cross linking the collagen molecules to give the woven bovine skin collagen adequate strength to possible function as a ligament repair scaffolding material. In the past, various cross linking agents including chromic 15 acid, cyanide gas, and glutaraldehyde have been used to treat various collagens in order to provide increased molecular cross linking that increases the strength thereof. However, these cross linking agents, although they do effectively cross link the 20 collagen materials, have also generally made the collagen materials even more antigenic than they normally are. It occurred to me that glutaraldehyde, which is used as a fixative for manufacture of hemostatic sponges and reduces the antigenicity thereof, 25 (see "Experimental and Clinical Experiences With Collagen Fleece as a Hemostatic Agent" by Silverstein et al., The Journal of Trauma, Volume 21, No. 5, page 388; "Collagen Fibers as a Fleece Hemostatic Agent", by Silverstein et al., The Journal of Trauma, 30 Volume 20, No. 8, page 688; and "Biological Effects of Residual Glutaraldehyde in Glutaraldehyde-Tanned Collagen Biomaterials", by Speer et al., Journal of Biomedical Materials Research, Volume 14, page 7753, (1980), might sufficiently effectively cross-link

SUBSTITUTE SHEET



woven bovine skin collagen fibers without making the material excessively dense or excessively antigenic to allow that collagen to be used as a ligament repair or replacement medium.

5

Initial experiments with woven bovine skin collagen material, which seems to be the only appropriate type because it is amorphous and loosely woven as opposed to many other collagens, such as tendon material, were to use the woven bovine skin collagen to repair tendons in the heels of rabbits. This resulted in a great deal of inflammation and scarring of the repaired heel tendon tissue, probably because the tanning chemicals used in manufacturing the collagen material were highly antigenic.

10
15

Later, pieces of "woven" bovine skin collagen were obtained from B. Braun, Inc. of Melsungen, Germany. These samples were previously woven as explained above with reference to Fig. 2, by B. Braun, Inc. I then treated these samples by soaking them for approximately two hours in 10% glutaraldehyde solution, after which the collagen was dried and hot gas sterilized with ethylene oxide (which is a common sterilization procedure).

20
25

Fig. 2 shows a print of a photomicrograph of the above described glutaraldehyde-treated woven bovine collagen mesh that is obtained from B. Braun, Inc. before treating it with glutaraldehyde by soaking it in a 10% glutaraldehyde solution to provide an antigenic scaffolding through which fibroblasts can propagate and around which a torn synovial can regenerate. The "woven" structure is

30

SUBSTITUTE SHEET

clearly shown in Fig. 2, wherein reference numeral 111 shows individual fibers of the woven bovine skin collagen. The general orientation of these fibers is in the vertical pattern indicated by the upper arrow. The thickness dimension of the illustrated piece of collagen is in the direction of the thickness of the sheet of paper on which Fig. 2 is printed. The so-called "weaving" process actually simply produces a subtle variation of the original bovine collagen "weave" pattern by gripping, orienting, and compressing the layers of skin collagen in a particular manner. Reference numeral 112 shows where the bovine skin collagen specimen was grasped by hooks of the compressing machine during the so-called weaving process.

This glutaraldehyde-treated woven bovine skin collagen material was then used to repair torn heel cords of rabbits by suturing a piece of the collagen material between torn ends of these tendons. Relatively little inflammation occurred, showing that the glutaraldehyde-treated woven bovine skin collagen material is relatively antigenic for ligament and tendon repair purposes.

In later experiments, the same type of glutaraldehyde-treated woven bovine skin collagen was used to repair and replace anterior cruciate ligaments in the knees of dogs; these ligaments are exposed to synovial fluid, although the posterior cruciate ligaments are not. The ends of the collagen repair material or medium were sutured between the torn ends of these ligaments. The dog's knees then were immobilized in casts for three to fifteen weeks. The animals

SUBSTITUTE SHEET



then were sacrificed and the normal ligaments and repaired ligaments were cross-sectioned and subjected to histologic analysis at various stages during the three to fifteen week periods. The analyses

5 showed that after as little as three to four weeks, the repaired ligaments appeared essentially identical to normal ligaments. The analyses also showed, very surprisingly, that new synovial sheaths had grown over the repaired ligaments and that fibro-

10 blasts of the original ligaments had grown and propagated through the scaffolding provided by the above-mentioned glutaraldehyde-treated woven bovine skin collagen material that had been sutured between the ends of the torn anterior cruciate

15 ligaments. The histologic analyses also showed that there were only faint hints of inflammatory reactions in the dogs' knee joints, not enough to prevent new growth of the synovial sheaths, which prevent the synovial fluid from attacking the

20 fibroblasts growing from the torn ends of the anterior cruciate ligaments and prevent them from growing through the collagen scaffolding. This result contrasts sharply with the results of other experiments that have shown that no such re-growth of the

25 synovial sheaths occurred for any previous ligament repair techniques or substitutes, such as using MARLEX or DEXON mesh or suturing of torn ends of anterior cruciate ligaments, or use of carbon fiber mesh material.

30

The structure shown in Figs. 8A and 8B illustrate how my original experiments were carried out. A piece of healthy ligament consisting of approximately a three-fourths cylinder section of the anterior

SUBSTITUTE SHEET

cruciate ligament 18 was removed, leaving only
a bottom section 18C connecting the two ends 18A
and 18B together. A piece of suitable length
glutaraldehyde-treated woven bovine skin collagen
5 material was inserted into the resulting gap in the
ligament 18 and sutured peripherally as shown in
Fig. 8A. However, the tensile weakness and the high
degree of friability of this peice of collagen
when it became wet due to blood and other fluids
10 caused considerable difficulty. By rolling a
rectangular piece of the same kind of collagen
material tightly into a small coil 16, as shown in
Fig. 5, and positioning it in the gap between sections
18A and 18B of ligament 18 and then suturing the
15 peripheries of the opposite ends of the coil 16
to sections 18A and 18B of anterior cruciate 18,
as indicated in Fig. 8A using tightly spaced
stitching with DEXON 5-0 or Prolene 6-0 suture
material. In order to avoid possible infection,
20 antibiotics were administered to the animals after
the operation.

In another experiment, an anterior cruciate ligament
of a dog knee was completely severed, as indicated
25 by reference numeral 18 in Fig. 8B, leaving separate
ligament sections 18A and 18B with a gap therebetween.
The glutaraldehyde-treated woven bovine skin collagen
coil 16 was positioned between these two torn ligament
sections; close stitching of the periphery of each
30 end of the torn ligaments to the opposite ends of the
collagen coil 16 was performed. After this implant-
ation of collagen coil 16, the joint was immobilized
by a cast for three weeks, and then at various
periods from three to fifteen weeks, the animals

were sacrificed and the repaired ligaments were subjected to histologic analyses.

The analyses showed that the use of the collagen coils to join the torn ligament sections provides much more surface area than a strip of the collagen material to greatly enhance the growth of the fibroblasts from the ends of the original ligament through the scaffolding structure of the collagen coil 16, resulting in essentially complete regeneration of the torn ligament section and only approximately three to four weeks. The coiled collagen configuration greatly facilitates the handling and stitching thereof and greatly increases the tensile strength of the repaired ligament immediately and during the initial part of the ligament regrowth process.

In other experiments illustrated generally by Fig. 6, one end of the collagen coil 16 was peripherally stitched to a torn end of an anterior cruciate ligament 19 of a dog's knee by means of sutures 20 after the surface of tibia or femur bone 21 had been drilled or chiseled to produce a void 22 three to five millimeters in depth therein. The lower end of the glutaraldehyde-treated woven bovine skin collagen coil was inserted all the way into the hole 22, and at the surface level of the bone 21 peripheral sutures 23 were utilized to attach the collagen coil 16 to the periosteum. As before, the joints were immobilized for varying periods of time from three to fifteen weeks, after which the animals were sacrificed and the ligaments and joints were subjected to histologic

SUBSTITUTE SHEET



analyses. These analyses showed that the ligament fibroblasts from ligament fibroblasts from ligament 19 had, within three to four weeks, regrown entirely through the collagen coil scaffolding 16 and had taken route in the bone material. Also, the bone had generated fibroblasts which had propagated toward ligament 19, as will be made clear subsequently.

In each of the previously described examples, by the time the histologic analyses were prepared, the collagen coil mesh had completely dissolved and did not appear in the analyzed biopsies.

Although experiments performed up to now have used glutaraldehyde treated woven bovine skin collagen that is obtained by the above-mentioned processing of ordinary cow skin by removing the outer layer, and then "weaving" it by gripping and twisting it in a certain manner, and pressing it to provide a suitable weave density and structure, and then cross linking it by soaking it in glutaraldehyde, other collagens having what I refer to as a "structural" type of weave may be used in the future. As an example, the collagen material obtained from a bandicoot tail may prove to be satisfactory. Fig. 3 shows the structure of a type of collagen that I refer to as a "structural collagen" as opposed to an "amorphous" type of collagen, which is what the bovine skin collagen is. It can be seen from Fig. 3 that the structure, which closely represents the structure of rodent tail collagen, is very densely woven. It is known to have a very high tensile strength. I believe that if it is properly manipulated and "woven" and then treated with glutaraldehyde, sufficient cross linking may be

accomplished, as indicated by reference numerals 30
in Fig. 5, to reduce the antigenicity enough to
avoid severe inflammatory reactions; these procedures
might be provided so as to result in a density that
5 is low enough to permit propagation of fibroblasts
and yet result in a sufficiently high tensile
strength that this "structural collagen" may be used
in the manner shown in Fig. 7 to replace torn
10 cruciate ligaments without immobilization of the
joint, or at least reducing the amount of time that
the joint has to be immobilized to considerably less
than three weeks, thereby allowing physical therapy
to begin as soon as possible.

15
In Fig. 7, the coil collagen mesh 35 extends
through two holes 33 and 34 that have been drilled,
respectively, through femur 2 and tibia 3. The
opposite ends of the coiled collagen mesh 35 are
20 stapled by means of metal staples 36 to the portions
of the bones indicated in Fig. 7. If the elongated
collagen coil mesh 35 has sufficient tensile strength,
the joint might not need to be immobilized, allowing
immediate physical therapy. (It should be appreciated
25 that the glutaraldehyde-treated woven bovine skin mesh
that I have used up to now in experiments is not
nearly as strong as healthy ligament tissue or healthy
tendon tissue. Therefore, it has been necessary to
immobilize the joints for at least three weeks).

30
Of course, the earliest possible physical therapy
is desirable to avoid atrophying and scarring of
regenerated ligament and/or tendon tissue and the
cartilage and associated muscles.

Referring now to Fig. 10, which is a print of a disarticulated dog's knee taken six weeks after the implantation of a glutaraldehyde-treated woven bovine skin collagen coil which was implanted to completely replace the original anterior cruciate ligament, which had been completely removed. Holes were drilled in both the femur 93A and tibia 93B at the points to which the original removed anterior cruciate ligament had been attached. The holes were drilled down into the cancellous bone tissue designated by reference numeral 21B in Fig. 6, and a coiled section of glutaraldehyde-treated woven bovine skin collagen was inserted into the two drilled out holes to replace the anterior cruciate ligament which had been removed; the collagen coil was peripheral-ly sutured to the periosteums of the femur 93A and tibia 93B. The joint was immobilized for three weeks, the dog was allowed to run for three weeks, and then the dog was sacrificed to obtain the analysis. Reference numeral 92 in Fig. 10 shows the completely regenerated and regrown anterior cruciate ligament that resulted. For all practical purposes this regenerated ligament is completely normal. Reference numeral 93 designates two ligament-bone interfaces, which appear to be completely normal both at the femur and the tibia. The knee shown appears to be a normal knee, and there appears to be no remnant of the collagen mesh, which at this point had completely dissolved. Fig. 9 is a diagram of the dog's knee joint and regenerated ligament of Fig. 10.

Fig. 11 is a print of a photomicrograph of a biopsy of a regenerated anterior ligament connection wherein glutaraldehyde-treated wove bovine skin collagen mesh was sutured to an anterior cruciate ligament in the knee of a dog; the synovial sheath was also completely torn. Fig. 11 clearly shows that the torn synovial sheath completely regenerated itself. In this case, the dog was sacrificed after six weeks from the implantation of the collagen coil. Reference numeral 86 represents the reconstituted ligament material. Reference numeral 87 represents a normal blood vessel therein. Reference numeral 88 refers to the regenerated or regrown synovial sheath that grew over the implanted glutaraldehyde-treated woven bovine skin collagen mesh that was implanted. It is to be noted that there is not indication of inflammatory reaction (which would appear as a darkened area) in the synovial sheath or underneath it in the regenerated ligament material 86. Superimposed dotted lines 89 show roughly what an inflammatory action would look like if there had been one. (Such an inflammatory reaction, if present, would cause a densely cellular layer of scar tissue to be formed.) Reference numeral 90 designates a clear or pale zone showing the normal collagen bundles that are beginning to form where the collagen coil was originally implanted.

Fig. 12 shows a print of a micrograph of a biopsy of an anterior cruciate ligament of a dog regenerated in accordance with the present invention. The dog was sacrificed six weeks after the collagen coil was sutured to the torn end of the ligament. Reference numeral 69 refers to the normal original

anterior cruciate ligament material. Reference numeral 70 refers to a normal blood vessel therein, which appears as a dark spot in the original ligament material 69. Reference numeral 71 designates
5 a dark spot that represents a healthy, normal ligament cell in the original ligament material 69. Reference numeral 72 refers to what appears as a pale zone in the biopsy, and designates normal ligament collagen bundles in the original ligament material 69.
10 Reference numeral 73 shows regenerated or regrown ligament material that has propagated through the collagen coil mesh in the dog's ligament during the six weeks after the collagen coil was implanted. There is no evidence in Fig. 12 of the collagen mesh
15 itself, which after six weeks had completely dissolved and disappeared. Reference numeral 74 shows a very gradual transition zone between the normal original ligament 69 and the region 73 where the collagen mesh was implanted. Reference numeral 75 shows a regrowing
20 blood vessel and the region 73 where the collagen mesh was implanted and the ligament has regenerated. Numeral 76 designated dark spots that show regrown ligament cells which are comparable to the ligament cells or fibroblasts 71. Reference numeral 77 shows reforming
25 mature collagen bundles that are comparable to the original collagen bundles 72. It is very significant that there are no inflammatory reactions (which would appear as dark areas) in transition zone 74 and in region 73.
30

Referring now to Fig. 13, which is a print of a photomicrograph of a biopsy of the junction between collagen mesh that was implanted in a holed drilled to the level of cancellous tissue in bone, wherein the

SUBSTITUTE SHEET



periphery of the collagen mesh coil had been sutured to the periosteum of the bone. Reference numeral 80 refers to regenerated ligament material which had propagated from fibroblasts in the cancellous tissue of the bone through the collagen coil such as 16 in Figs. 5 and 6, by the end of a twelve week period in the knee of a dog. Reference numeral 81 refers to regenerated ligament cells that appear to be perfectly normal. Note that in this portion of a ligament there are normally very few blood vessels. Note also that in this case, there was initially no ligament present at all; the original ligament had been removed and the portion of the bone 82 to which the original ligament was attached had been completely drilled out down into cancellous bone tissue. Reference numeral 82 refers to normal bone tissue which has regenerated in the drilled hole in which one end of the collagen coil was implanted. Reference numeral 83 refers to regenerated bone cells which appear to be normal in this region. The white spots with dark dots therein represent normal bone cells 83. Note that there are normally very few blood vessels in this part of the bone. Reference numeral 84 designates an irregular interface of calcification between regenerated bone and regenerated ligament that also has been regenerated in accordance with the method of the invention. This interface region forms as result of a condensation reaction between calcium and other minerals to form what appears in Fig. 13 as a regenerated calcification interface. The appearance of regenerated recalcification line 84 appears, after twelve weeks from implantation of the collagen coil, to be perfectly normal.

SUBSTITUTE SHEET

Note that the process described above with reference to Fig. 13 makes possible the complete regeneration of anterior cruciate ligaments such as 11 in Fig. 9 and 92 in Fig. 10 by regenerating not
5 only ligament tissue, but also a perfect ligament-bone interface to the femur and tibia bones.

Fig. 14 shows what happens when MARLEX mesh is used in a human body as a ligament replacement.
10 Reference numeral 97 designates normal ligament material. Reference numeral 98 designates the location of MARLEX mesh. Reference numeral 99 designates a very abrupt transition between the normal ligament material and the MARLEX mesh six weeks after
15 implantation of the MARLEX mesh by suturing it to the torn end of an anterior cruciate ligament in a human knee. No gradual transition between the MARLEX and normal ligament material appears, as was the case when glutaraldehyde treated wove bovine
20 skin collagen is implanted in a dog's knee, in which case the torn ligament regenerates itself by growing through the scaffolding provided by the collagen mesh in accordance with the present invention. The dark areas, such as the ones designated by reference numeral
25 100, indicate dense, severe, inflammatory reactions that accompany the presence of the MARLEX mesh in the human knee. The clear areas indicated by reference numeral 101 show normal collagen bundles in the normal ligament in Fig. 14. There are none of these normal collagen
30 bundles appearing in region 98 with the MARLEX mesh.

Fig. 15 shows, after six weeks, where woven DEXON material was implanted and sutured to a torn anterior cruciate ligament in a human knee to repair it. Reference

numeral 104 generally designates the implanted DEXON mesh. Reference numeral 105 shows normal ligament material to which the DEXON mesh was sutured. Reference numeral 106 shows a very abrupt transition
5 between the normal ligament material 105 and the DEXON material 104. Reference numeral 107 shows isolated DEXON synthetic fibers; these fibers clearly have not been absorbed during the six weeks of implantation.
10 Reference numeral 108 indicates black areas which represent intense inflammatory reaction that accompanies the presence of DEXON material in the human knee. The light areas pointed to by reference numeral 109 show normal collagen fiber bundles in the normal ligament
15 tissue 105; none of this normal collagen fiber bundle tissue is present in the region 104 in which DEXON material is present.

Fig. 16 is a print of a photomicrograph of
20 a carbon fiber ligament after it has been implanted in a human knee for roughly 18 months. Reference numerals 112 show individual carbon fibers which have undergone extensive fracturing and disorientation during the eighteen months. Reference numerals 113 designate
25 dark areas that indicate regions of severe cellular inflammation around the individual carbon fibers. Note that in Fig. 16, there is an absence of healthy, well organized collagen bundles of ligament tissue that are present in healthy human anterior cruciate
30 ligaments.

There are two basic chemical reactions which occur when protein molecules of a collagen are cross-linked by glutaraldehyde. The following chemical formula
35 illustrates this.

FORMULA 1

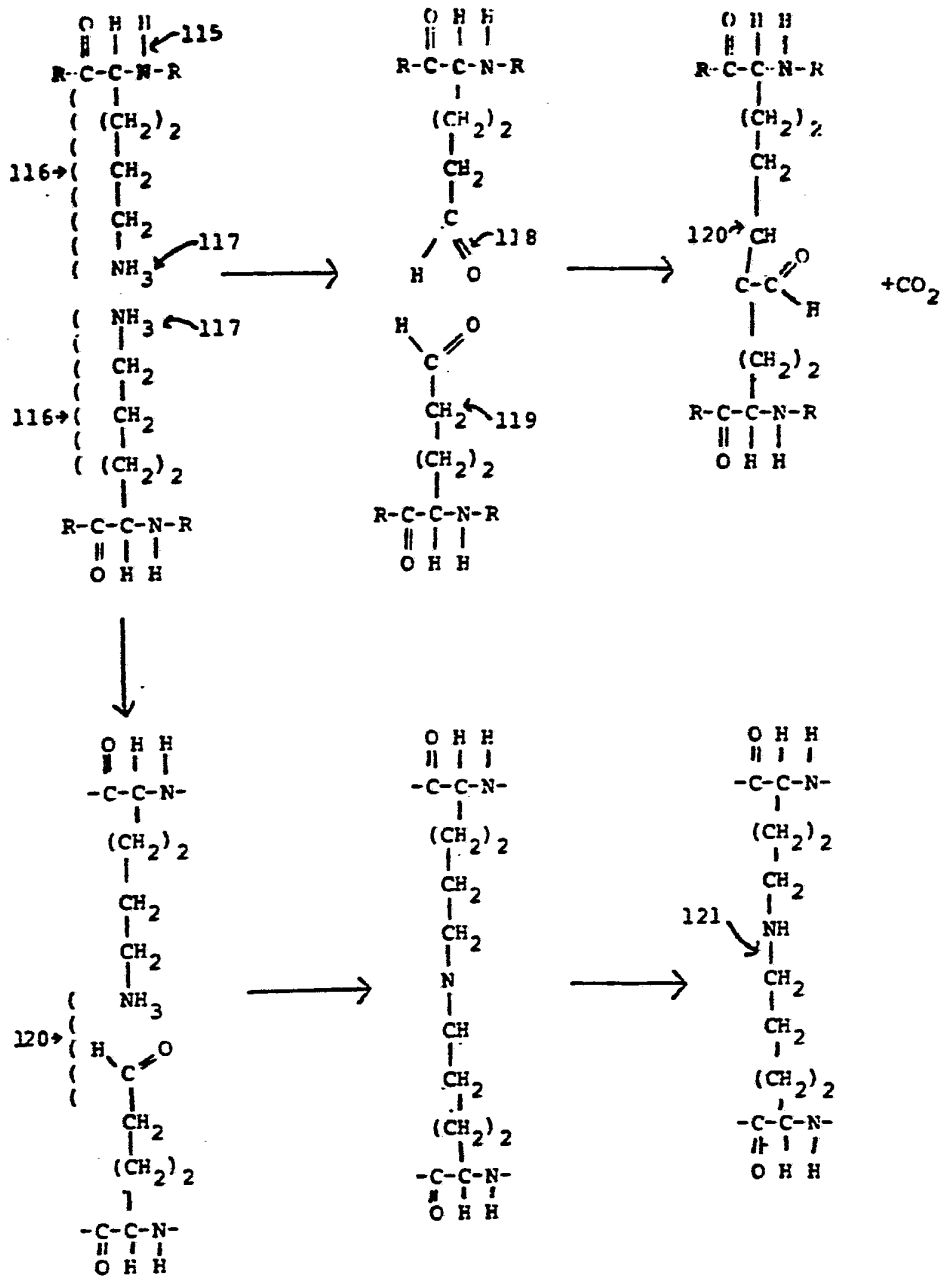

In Formula 1, reference numeral 115 refers to the amino acid chains which form the protein collagen backbone. Reference numeral 116 refers to the side chains that extend from the side of the protein molecules. The one designated by reference numeral 16 is lysine, an amino acid. Reference numeral 117 refers to the amine groups or terminal groups, which are the reactive groups that are desired to be joined in the cross-linking process when the collagen is treated with glutaraldehyde or other similar cross-linking agents, such as other aldehydes.

The reaction generally designated by the upper half of Formula 1 is a condensation reaction, and the reaction represented by the lower half of Formula 1 is a base shift reaction.

Formula 1 represents two kinds of cross-linking of the woven bovine skin collagen that occur as a result of being treated with glutaraldehyde. The net result of both types of cross-linking is essentially the same, even though there are subtle differences in the chemical bonding that occurs as a result of the two reactions.

The molecules designated by reference numeral 118 bond with the molecules indicated by reference numeral 119 to produce the condensation reaction. R represents the "rest" of the protein chain that is not shown in Formula 1. Reference numeral 120 at the bottom of Formula 1 refers to a slightly different base shift chemical reaction that occurs when proteins are cross-linked using glutaraldehyde. This reaction

is an oxidation and differs from the condensation reaction shown in the upper part of Formula 1 in that there is a different bond between the two protein chains. But the next effect of each is a stable chemical cross linking bond. The qualities of both reactions are that neither leave any reactive side groups or radicals which will be reacted to be human or animal bodies by causing severe inflammatory reactions. In effective cross-linking, all of the reactive side groups or radicals participate in the cross-linking. This is in contrast to other cross-linking agents, such as chromates, which do result in effective cross-linking, but also leave a salt of the chromate hanging unbonded to the linking molecule; the salt then causes a severe inflammatory reaction.

The undesirable reactive groups or radicals can be some other group that a salt of the molecule that has been oxidized by a cross-linking action process and thereby made reactive or antigenic. These undesired reactive groups are ones that are not capable of participating in the cross-linking process, however, and are referred to herein simply as radicals. Frequently, they are amines or carboxyl groups. Most radicals are antigenic. Herein, desirable cross-linking agents are referred to herein as ones that do not have an attached radical that cannot participate in the cross-linking process. The radical could be any part of the cross-linking molecule that oxidizes in the cross-linking treatment process and does not have an attached radical that the body will attack to produce an inflammation.

The Glutaraldehyde-treated woven bovine skin collagen technique of the present invention is expected to be very useful not only in repair of ligaments which are exposed to synovial fluid, but also to ligaments which are not exposed to synovial fluid and also to tendons because even though the tendons and latter mentioned ligaments can be successfully repaired by suturing the torn ends together, it is technically impractical to actually properly suture each one of the torn bundles of fibers together. Therefore, in repairing such ligaments and tendons by suturing, one generally simply sutures or staples the torn ends of the ligament together. A biopsy of the resulting repaired ligament, after healing is complete, will show tissue structure that varies considerably from that of normal healthy ligament or tendon tissue in that there is scar tissue which is very disorganized and that the ligament or tendon material in the repaired region is less well cross-linked than is the case for healthy tissue. As a result, the tensile strength of ligaments or tendons which have been repaired by suturing the torn ends together is not nearly as great as the tensile strength of corresponding healthy ligament or tendon tissue. Due to these shortcomings of previous successful attempts to suture together loose ends of torn tendons or ligaments not exposed to synovial fluid, the method and collagen of the present invention to provide scaffolding through which fibroblasts can propagate to regenerate ligament or tendon tissue is expected to be an important application of the invention. In Figs. 17 and 18, which show photomicrographs of biopsys of a torn medial collateral ligament of a human knee, the torn ends of which have been sutured together and allowed to heal

for twelve weeks, reference numerals 124 indicates such disorganized, relatively weak scar tissue.

5 The techniques and materials described herein provide the great advantage of allowing, for the first time, reliable repair of anterior cruciate ligaments and other ligaments that are exposed to synovial fluid. The techniques and materials described further allow essentially complete
10 regeneration of normal-appearing ligaments from cancellous bone tissue, and also allow, for the first time, regeneration of normal-appearing bone/ligament calcification interface regions, even if the original ligament has been previously completely
15 removed. The described techniques and materials allow, for the first time, regeneration of the synovial sheath which protects some ligaments, such as anterior cruciate ligaments, from digestion by synovial fluid. The described techniques and materials also
20 allow, for the first time, repair of tendons and ligaments without the generation of relatively weak, disorganized scar tissue that ordinarily grows where torn ends of ligaments or tendons have been sutured together in accordance with prior techniques.
25 Remobilization of joints much sooner after surgery is made possible by the techniques and materials of the present invention, which is very desirable to prevent atrophy of all related tissue.

30 While the invention has been described with reference to particular embodiments thereof, those skilled in the art will be able to make various modification to the described techniques without departing from the true spirit and scope of the
35 invention. For example, other chemical cross-linking

SUBSTITUTE SHEET



agents, possibly acetic acid or cross-linking agents that do not have an attached radical that cannot participate in the cross-linking process can be used to cross-link the woven bovine skin collagen, or possibly other collagens having higher tensile strength, but not being too dense to permit propagation of fibroblasts after the cross-linking process, so that the final cross-linked collagen is sufficiently non-antigenic to prevent inflammation severe enough to prevent re-growth of the synovial sheath or propagation of fibroblasts through the collagen. Other collagen configurations than the described collagen coil might be used to overcome the problems of friability of the weak tensile strength of glutaraldehyde-treated woven bovine skin collagens.



SUBSTITUTE SHEET

I CLAIM:

1. A method of repairing a torn end of a ligament or tendon, said method comprising the steps of:

5

a) treating a piece of loosely woven collagen with glutaraldehyde to increase the amount of cross-linking between amino acid groups of separate protein strands of said piece of collagen and to reduce antigenicity of said piece of collagen; and

10

b) attaching a first edge portion of said piece of collagen to a first torn end portion of said ligament or tendon;

15

wherein said piece of collagen functions as a non-antigenic scaffolding through which fibroblasts from said first torn end of said ligament or tendon can grow to form regenerated ligament or tendon tissue.

20

2. A method of repairing a torn end of a ligament or tendon, said method comprising the steps of:

25

a) treating a piece of loosely woven collagen with glutaraldehyde to increase the amount of cross-linking between amino acid groups of separate protein strands of said piece of collagen and to reduce antigenicity of said pieces of collagen;

30

SUBSTITUTE SHEET

b) producing a hole in the surface of a bone to which said ligament or tendon is to be attached, said hole extending into cancellous tissue of said bone;

5

c) inserting an end portion of said piece of collagen into said hole to touch said cancellous tissue; and

10

d) attaching a part of said end portion to the periosteum of said bone to hold said end portion in contact with said cancellous tissue.

15

3. A method of repairing a torn anterior cruciate ligament of a joint, the synovial sheath of said anterior cruciate ligament also being torn, said method comprising the steps of:

20

a) treating a piece of loosely woven collagen with glutaraldehyde to increase the amount of cross-linking between amino acid groups of separate protein strands of said piece of collagen and reduce antigenicity of said piece of collagen; and

25

b) attaching a first edge portion of said piece of collagen to a first torn end portion of said anterior cruciate ligament,

30

wherein said piece of collagen functions as a non-antigenic scaffolding material through which fibroblasts

SUBSTITUTE SHEET

from said first torn end portion of said anterior
cruciate ligament can grow and become connected to
other portions of said ligament or to a bone of
said joint to form regenerated anterior cruciate
5 ligament tissue and around which new synovial sheath
material grows to isolate said first torn end
portion and said fibroblasts from digestion by synovial
fluid that exists in the vicinity of said anterior
cruciate ligament.

10

4. The method of Claim 3 wherein said piece
of collagen is sufficiently loosely woven to encourage
rapid growth of fibroblasts from said first end
15 portion of said anterior cruciate ligament through
said piece of collagen.

5. The method of Claim 3 including attaching a
20 second edge portion of said piece of collagen to a
second torn end portion of said anterior cruciate
ligament.

25 6. The method of Claim 3 including the steps of
creating a hole in the joint surface of a first one
of the bones forming said joint, said hole extending
into bleeding cancellous bone tissue of said first bone,
inserting a second edge portion of said piece of
30 collagen into said hole to contact said bleeding cancel-
lous tissue, and attaching a portion of said piece
of collagen at the level of said joint surface to the
periosteum surrounding said hole.

7. The method of Claim 6 wherein said attaching of said piece of collagen to said periosteum is performed by suturing.

5

8. The method of Claim 4 including immobilizing said joint for approximately three weeks and then remobilizing said joint and causing exercise therapy of said joint and only associated muscles, ligaments and tendons.

10

9. The method of Claim 4 wherein said collagen is woven bovine skin collagen.

15

10. The method of Claim 4 wherein said collagen is structural collagen material.

20

11. The method of Claim 3 including rolling said piece of collagen up into a coiled roll before step (6) wherein said attaching includes suturing the peripheral edge portion of a first end of said coiled roll to a peripheral portion of said first torn end portion of said anterior cruciate ligament.

25

12. A method of repairing a torn anterior cruciate ligament of a joint, the synovial sheath of said anterior cruciate ligament also being torn, said method comprising the steps of:

30



SUBSTITUTE SHEET

5 a) treating a piece of loosely woven collagen with glutaraldehyde to increase the amount of cross-linking between amino acid groups of separate protein strands of said piece of collagen and reduce antigenicity of said piece of collagen;

10 b) producing a hole in the surface of a bone to which said ligament or tendon is to be attached, said hole extending into cancellous tissue of said bone;

15 c) inserting a first end portion of said piece of collagen into said hole to touch said cancellous tissue; and

20 d) attaching a part of said first end portion to the periosteum of said bone to hold said first end portion in contact with said cancellous tissue, wherein said collagen functions as non-antigenic scaffolding material through which fibroblasts from said cancellous tissue grow to form regenerated anterior cruciate ligament tissue around which new synovial sheath material grows to isolate said fibroblasts and
25 said regenerated anterior cruciate ligament tissue from digestion by synovial fluid that exists in the vicinity of said anterior cruciate ligament.

30

13. The method of Claim 12 including suturing a second end portion of said piece of collagen to a

SUBSTITUTE SHEET



torn end of said torn anterior cruciate ligament.

14. A method of repairing a torn ligament of a
5 joint, said method comprising the steps of:

a) treating a piece of loosely woven
collagen with glutaraldehyde to increase the
amount of cross-linking between separate
10 protein strands of said piece of collagen and
reduce antigenicity of said piece of collagen;

b) completely removing said torn ligament
from said joint;

15

c) producing a first hole in the surface
of a first bone of said joint, said first hole
extending into cancellous tissue of said first
bone and producing a second hole in the
20 surface of a second bone of said joint, said
second hole extending into cancellous tissue of
said second bone;

d) inserting a first end portion of said
25 piece of collagen into said first hole and in
contact with cancellous tissue of said first
bone, and inserting a second end portion of
said piece of collagen into said second hole
and in contact with cancellous tissue of said
30 second bone; and

e) attaching said first and second end
portions of said piece of collagen to said
first and second bones, respectively, to hold

SUBSTITUTE SHEET



said first and second end portions in contact with cancellous bone tissue in said first and second holes, respectively.

5 wherein said piece of collagen functions as non-antigenic scaffolding material through which fibroblasts from cancellous tissue in said first and second holes can rapidly grow to form a complete regenerated ligament and regenerated calcified ligament/bone interfaces
10 between said regenerated ligament and said first and second bones.

15 15. The method of Claim 14 wherein said torn ligament is an anterior cruciate ligament, the synovial sheath around said anterior cruciate ligament also being torn, a new regenerated synovial sheath forming to protect said fibroblasts and said regenerated ligament.

20 16. The method of Claim 15 including the step of suturing peripheral portions of said first and second end portions of said piece of collagen to the periosteums of said first and second end portions of
25 first and second bones, respectively.

30 17. The method of Claim 15 wherein said first and second holes extend all the way through said first and second bones, respectively, said method including the steps of passing said first and second end portions of said piece of collagen all the way through said first and second holes, respectively, and stapling them to said first and second bones, respectively.

18. A method of repairing a torn end of a ligament or tendon, said method comprising the steps of:

5 a) treating a piece of loosely woven collagen with a cross-linking chemical to increase the amount of cross-linking between amino acid groups of separate protein strands of said piece of collagen and to reduce
10 antigenicity of said piece of collagen, said cross-linking chemical having the property that after the cross linking by said chemical is completed, it has a negligible number of attached radicals which can cause inflammatory
15 reaction in said ligament or tendon;

 b) attaching a first edge portion of said piece of collagen to a first torn end portion of said ligament or tendon;

20

wherein said piece of collagen functions as a non-antigenic scaffolding through which fibroblasts from said torn end of said ligament or tendon can grow to form regenerated ligament or tendon tissue.

25

19. A method of repairing a torn end of a ligament or tendon, said method comprising the steps of:

30 a) treating a piece of loosely woven collagen with a cross-linking chemical to increase the amount of cross-linking between amino acid groups of separate protein strands of said piece of collagen and to reduce anti-

SUBSTITUTE SHEET



genicity of said piece of collagen, said cross-linking chemical having the property that after the cross-linking by said chemical is completed, it has a negligible number of attached radicals which can cause inflammatory reaction in said ligament or tendon;

b) producing a hole in the surface of a bone to which said ligament or tendon is to be attached, said hole extending into cancellous tissue of said bone;

c) inserting an end portion of said piece of collagen into said hole to touch said cancellous tissue; and

d) attaching a part of said end portion to the periosteum of said bone to hole said end portion in contact with said cancellous tissue.

20. A repair medium for a torn ligament or tendon, comprising in combination:

a) a piece of loosely woven glutaraldehyde treated bovine skin collagen; and

b) suturing means for attaching a first edge portion of said piece of collagen to a first torn end portion of said ligament or tendon,

wherein said piece of collagen functions as a non-antigenic scaffolding through which fibroblasts from

SUBSTITUTE SHEET



said first torn end portion of said ligament or tendon can grow to form regenerated ligament or tendon tissue.

5

21. The repair medium of Claim 17 wherein said piece of collagen is a coiled roll of collagen material.

10

22. A repair medium for a torn ligament or tendon, comprising in combination:

15 a) a piece of loosely woven collagen with chemical cross-linking which increases the tensile strength of said piece of collagen by a predetermined amount and reduces the anti-genicity of said piece of collagen enough to avoid unacceptable inflammation in tendon tissue
20 that grows through said piece of collagen; and

25

b) means for attaching a first end portion of said piece of collagen to said torn ligament or tendon,
said piece of collagen function as a non-antigenic scaffolding material through which fibroblasts from said first end portion rapidly grow to form regenerated ligaments or tendon tissue.

30

23. The repair medium of Claim 22 including means for attaching a second end portion of said piece

SUBSTITUTE SHEET

of collagen to a bone to hold said second end portion in a hole extending into cancellous tissue of said bone and in contact with said cancellous tissue, said piece of collagen also functioning as scaffolding material through which fibroblasts from said cancellous tissue rapidly grow to form a regenerated calcification bone/ligament or bone/tendon interface.

24. A repair medium for a torn ligament, comprising in combination:

a) a piece of loosely woven collagen with chemical cross-linking that provides a predetermined amount of tensile strength in the collagen and reduce the antigenicity of said piece of collagen to a level that avoids unacceptable inflammation that would prevent growth of fibroblasts through said piece of collagen; and

b) means for attaching a first end portion of said piece of collagen to a bone by holding said first end portion in a hole extending from a surface of said hole into cancellous tissue of said bone and in contact with said cancellous tissue,

said piece of collagen functioning as a non-antigenic scaffolding material through which fibroblasts from said cancellous tissue rapidly grow to regenerate said torn ligament and to regenerate a bone/ligament calcification interface.

SUBSTITUTE SHEET



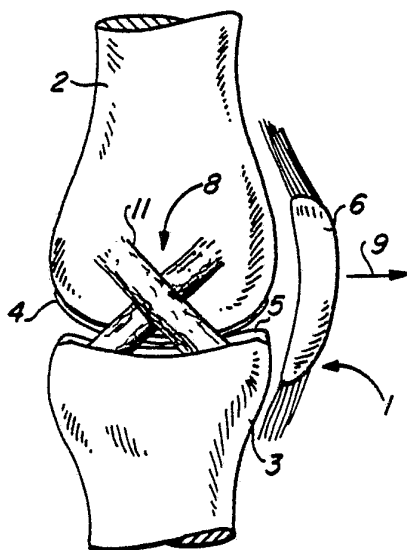

FIG. 1

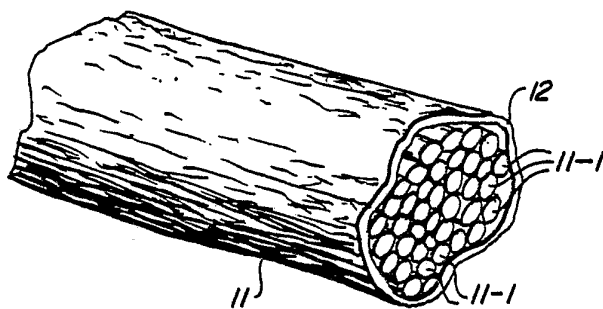

FIG. 1C

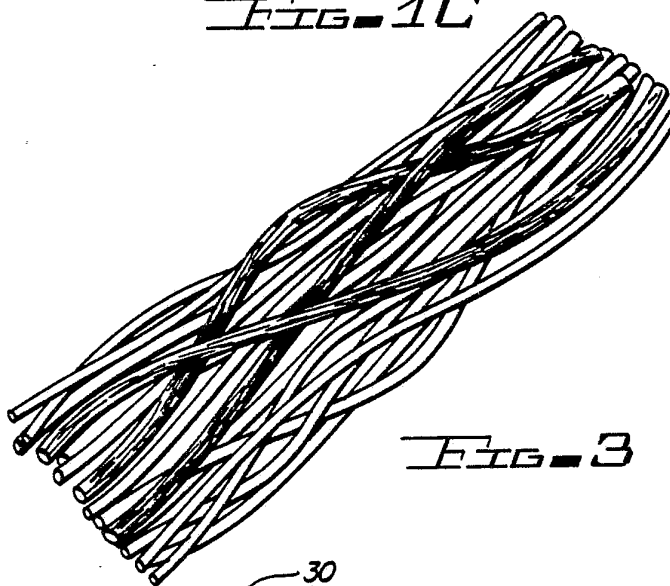

FIG. 3

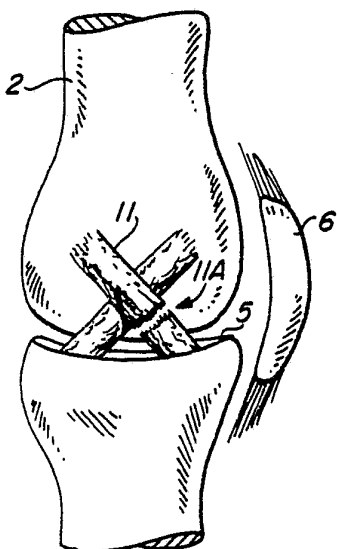

FIG. 1A

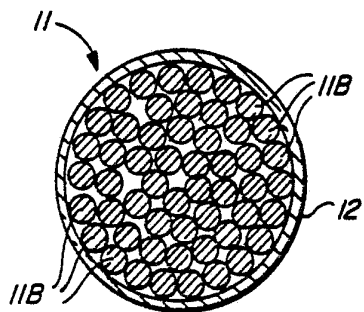
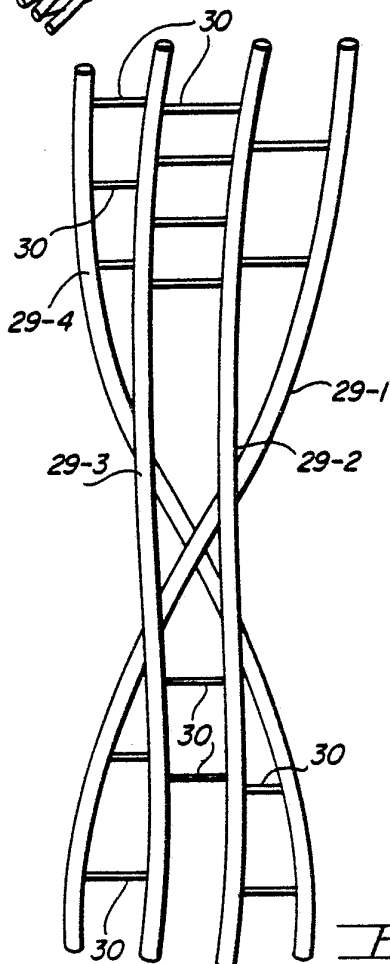
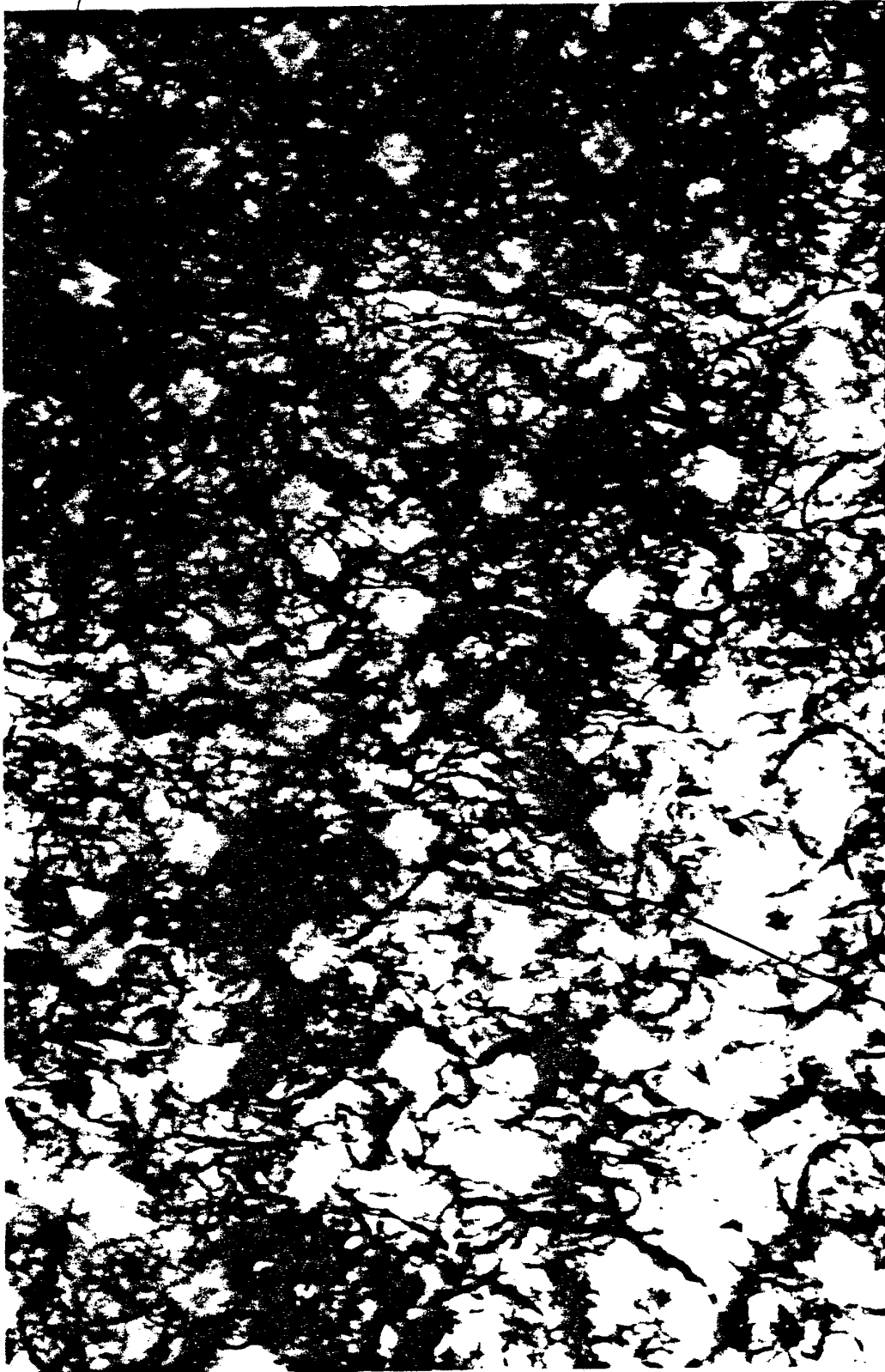

FIG. 1B



112



111A

111

111

111B

SUBSTITUTE SHEET



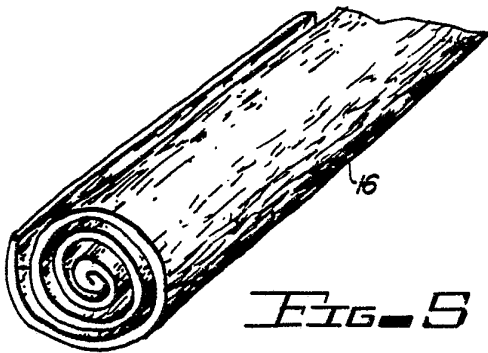

FIG. 5

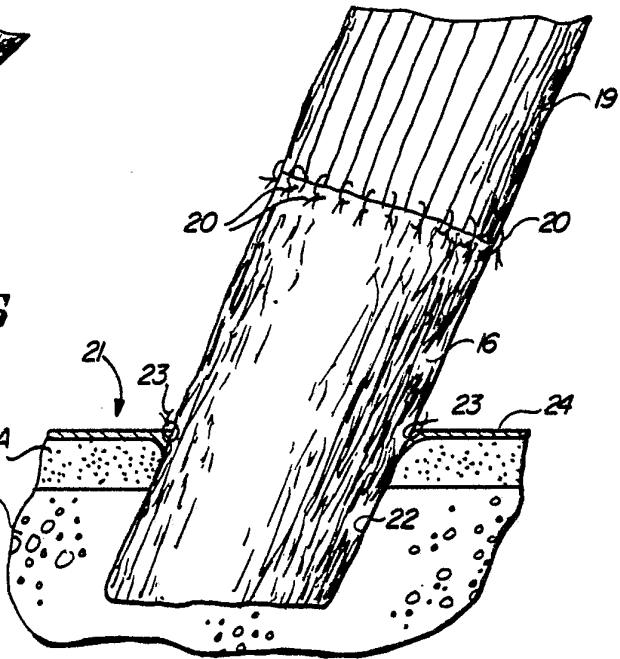

FIG. 6

FIG. 7

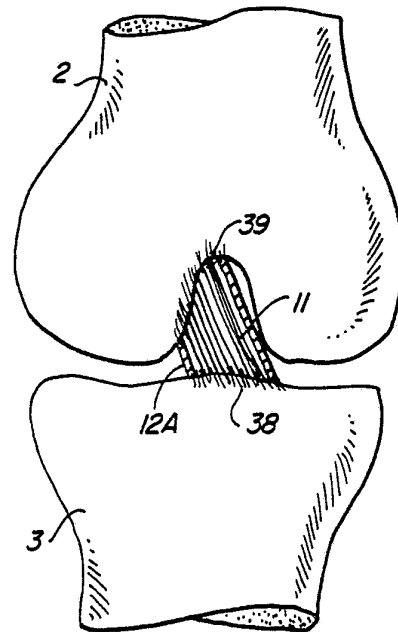
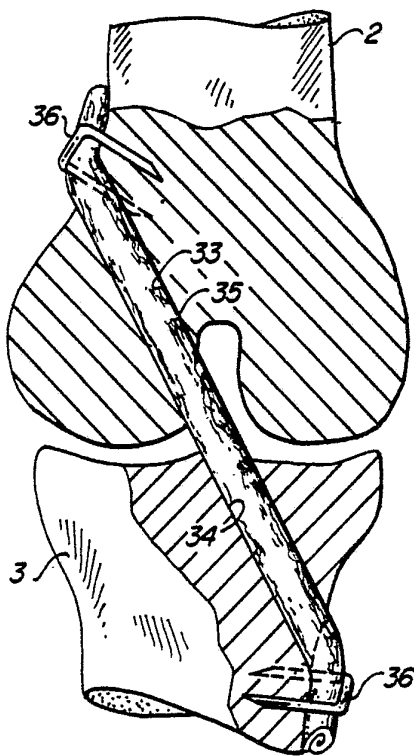

FIG. 9

FIG. 8A

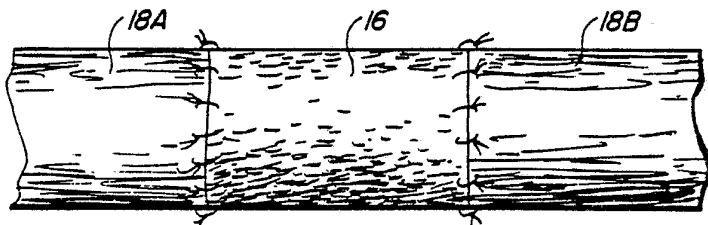
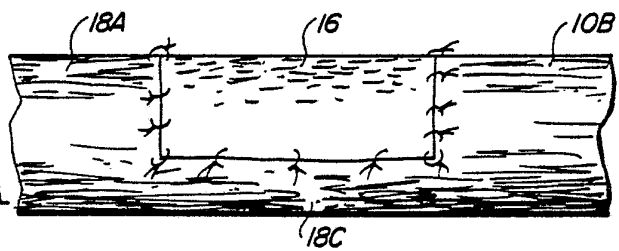

FIG. 8B

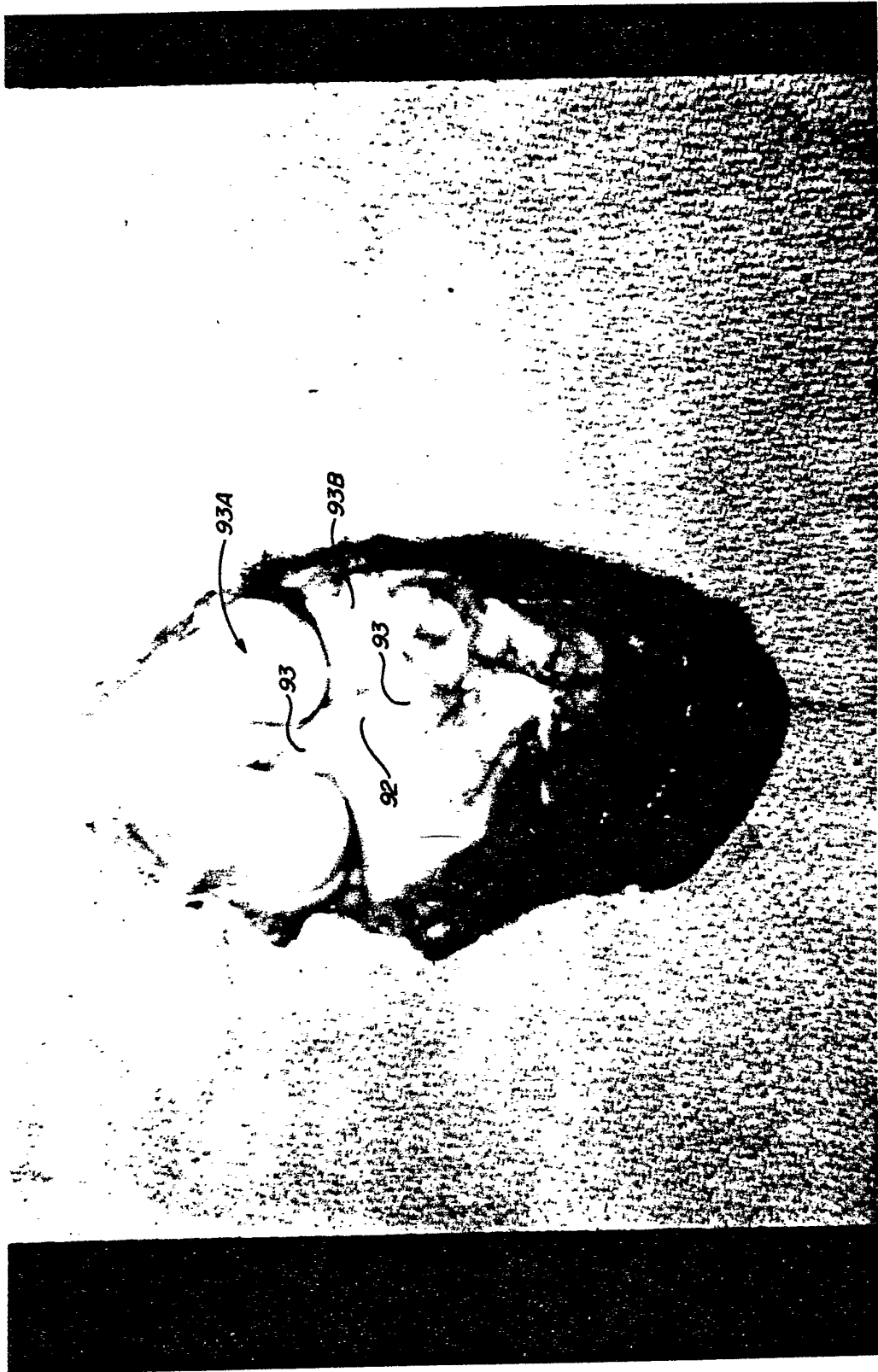

FIG-10

SUBSTITUTE SHEET



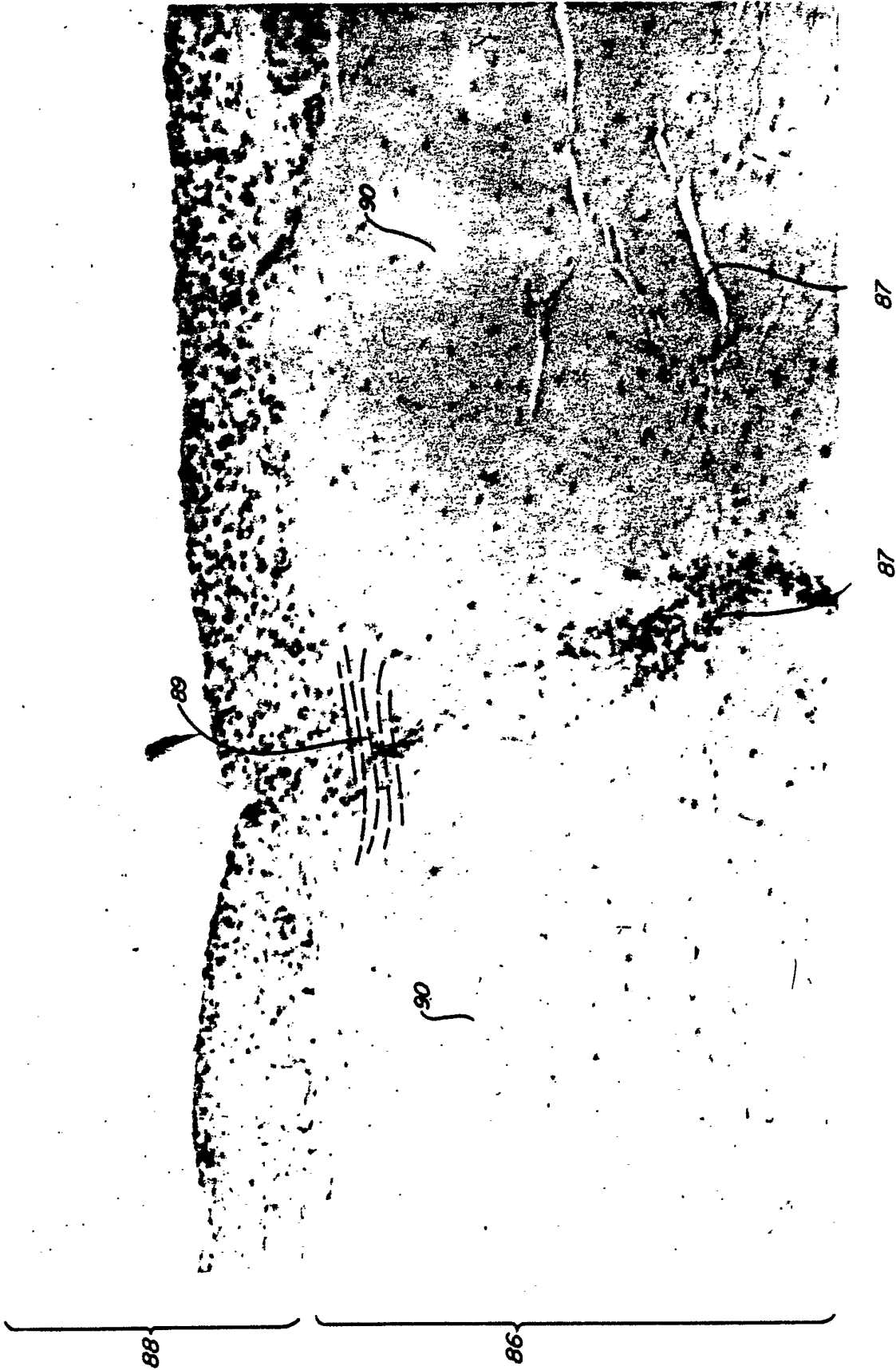
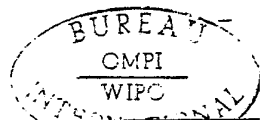

FIG. 11

SUBSTITUTE SHEET





SUBSTITUTE SHEET



7/12



FIG. 13

82

80

SUBSTITUTE SHEET



8/12



FIG. 14

SUBSTITUTE SHEET



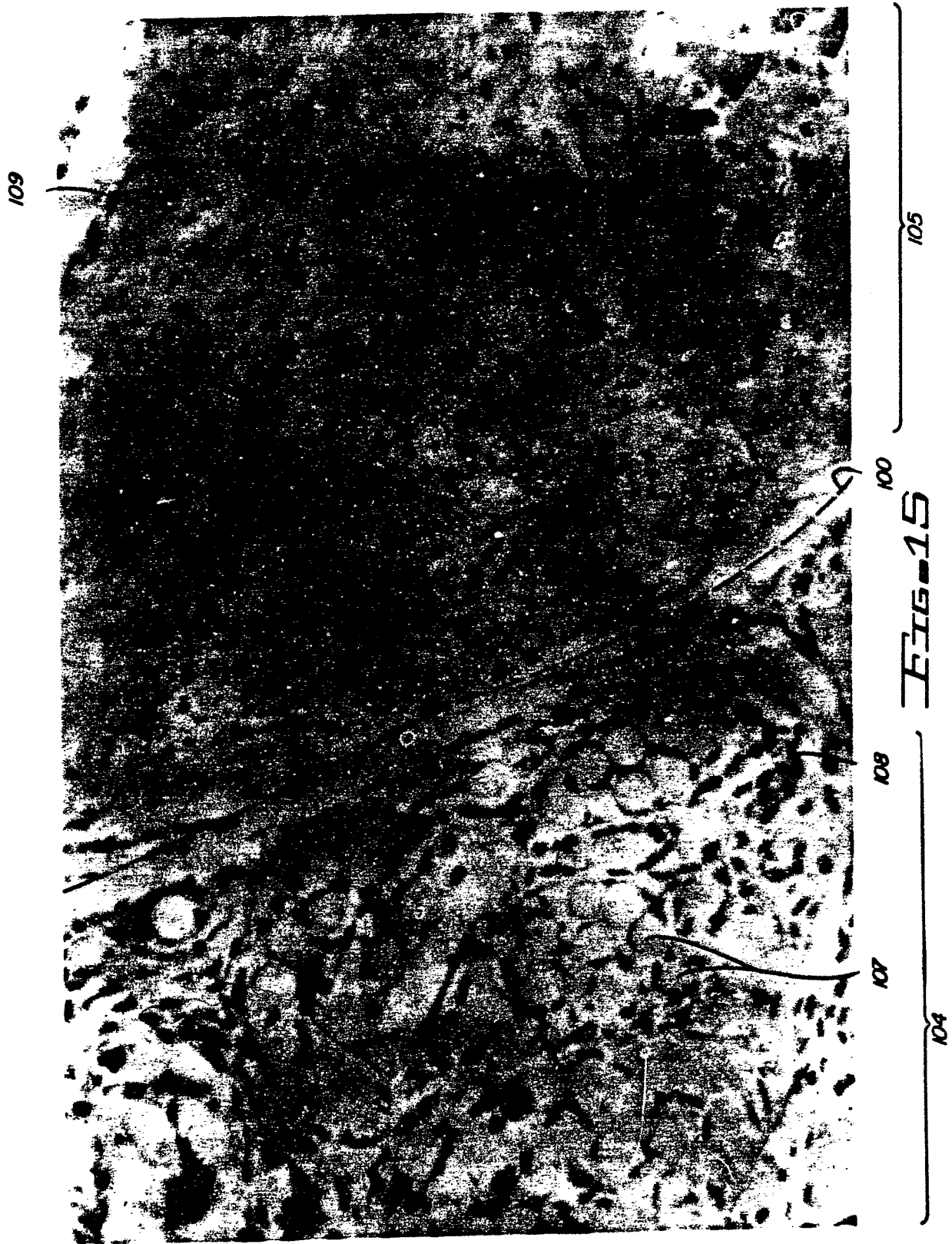

10/12



FIG. 16

113

113

SUBSTITUTE SHEET





FIG. 17

SUBSTITUTE SHEET



12/12



FIG. 18

SUBSTITUTE SHEET



INTERNATIONAL SEARCH REPORT

International Application No **PCT/US 84/01186**

I. CLASSIFICATION OF SUBJECT MATTER (if several classification symbols apply, indicate all) ³		
According to International Patent Classification (IPC) or to both National Classification and IPC IPC: A61F 1/00, A61F 5/04 U.S. CL: 3/1		
II. FIELDS SEARCHED		
Minimum Documentation Searched ⁴		
Classification System	Classification Symbols	
US	3/1, 1.4, 1.5, 1.3, 1.91 128/92C, 334R, 1R, 155, 156 424/94.34	604/830, 881 8/94.11
Documentation Searched other than Minimum Documentation to the Extent that such Documents are Included in the Fields Searched ⁵		
III. DOCUMENTS CONSIDERED TO BE RELEVANT ¹⁴		
Category [*]	Citation of Document, ¹⁶ with indication, where appropriate, of the relevant passages ¹⁷	Relevant to Claim No. ¹⁸
Y,P	U.S. A, 4400833 (Kurland) 30 August 1983	1-24
Y,P	U.S. A, 4458678 (Yannas et al) 10 July 1984	1-24
Y	U.S. A, 4378224 (Nimni et al) 29 March 1983	1-24
E,Y	U.S. A, 4467478 (Jurgutis) 28 August 1984	1-24
<p>[*] Special categories of cited documents: ¹⁵</p> <p>"A" document defining the general state of the art which is not considered to be of particular relevance</p> <p>"E" earlier document but published on or after the international filing date</p> <p>"L" document which may throw doubts on priority claim(s) or which is cited to establish the publication date of another citation or other special reason (as specified)</p> <p>"O" document referring to an oral disclosure, use, exhibition or other means</p> <p>"P" document published prior to the international filing date but later than the priority date claimed</p> <p>"T" later document published after the international filing date or priority date and not in conflict with the application but cited to understand the principle or theory underlying the invention</p> <p>"X" document of particular relevance; the claimed invention cannot be considered novel or cannot be considered to involve an inventive step</p> <p>"Y" document of particular relevance; the claimed invention cannot be considered to involve an inventive step when the document is combined with one or more other such documents, such combination being obvious to a person skilled in the art.</p> <p>"&" document member of the same patent family</p>		
IV. CERTIFICATION		
Date of the Actual Completion of the International Search ²	Date of Mailing of this International Search Report ²	
10/2/84	12 OCT 1984	
International Searching Authority ¹	Signature of Authorized Officer ²⁰	
RO/US	