



- (51) International Patent Classification: US 13/107,759 (CIP)
A61B 18/18 (2006.01) Filed on 13 May 2011 (13.05.2011)
- (21) International Application Number: PCT/US2012/037551
- (22) International Filing Date: 11 May 2012 (11.05.2012)
- (25) Filing Language: English
- (26) Publication Language: English
- (30) Priority Data:
61/486,206 13 May 2011 (13.05.2011) US
61/485,621 13 May 2011 (13.05.2011) US
13/107,720 13 May 2011 (13.05.2011) US
13/107,759 13 May 2011 (13.05.2011) US
- (63) Related by continuation (CON) or continuation-in-part (CIP) to earlier applications:
US 13/107,720 (CIP)
Filed on 13 May 2011 (13.05.2011)
- (71) Applicant (for all designated States except US): BRONCUS TECHNOLOGIES, INC. [US/US]; 1400 N. Shoreline Blvd., Bldg A, Suite 8, Mountain View, CA 94043 (US).
- (72) Inventor; and
(75) Inventor/Applicant (for US only): LAUFER, Michael, D. [US/US]; 1259 El Camino Real, #211, Menlo Park, CA 94025 (US).
- (74) Agents: GIOVANNETTI, Steven, M. et al.; Levine Bagade Han LLP, 2400 Geng Road, Suite 120, Palo Alto, CA 94303 (US).
- (81) Designated States (unless otherwise indicated, for every kind of national protection available): AE, AG, AL, AM, AO, AT, AU, AZ, BA, BB, BG, BH, BR, BW, BY, BZ, CA, CH, CL, CN, CO, CR, CU, CZ, DE, DK, DM, DO, DZ, EC, EE, EG, ES, FI, GB, GD, GE, GH, GM, GT, HN, HR, HU, ID, IL, IN, IS, JP, KE, KG, KM, KN, KP, KR,

[Continued on next page]

(54) Title: METHODS AND DEVICES FOR ABLATION OF TISSUE

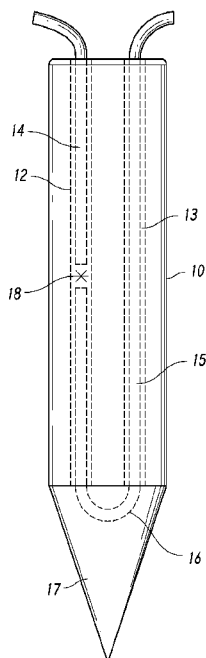

FIG. 1

(57) Abstract: Various apparatus and methods for ablating tissue are described therein. In certain variations, a method for ablating tissue may include advancing one or more electrodes, e.g., a first electrode and a second electrode, to or near a target tissue in a subject. The electrodes may be energized such that the electrodes create a plasma arc. The plasma arc generates heat which desiccates or ablates the target tissue. An apparatus for ablating tissue may include an elongate instrument, e.g., a tube or rod. One or more electrodes, e.g., a first electrode and a second electrode, may be provided in the elongate instrument. The electrodes may be energized such that the electrodes create a plasma arc for generating heat to desiccate or ablate a target tissue.

KZ, LA, LC, LK, LR, LS, LT, LU, LY, MA, MD, ME, MG, MK, MN, MW, MX, MY, MZ, NA, NG, NI, NO, NZ, OM, PE, PG, PH, PL, PT, QA, RO, RS, RU, RW, SC, SD, SE, SG, SK, SL, SM, ST, SV, SY, TH, TJ, TM, TN, TR, TT, TZ, UA, UG, US, UZ, VC, VN, ZA, ZM, ZW.

(84) Designated States (unless otherwise indicated, for every kind of regional protection available): ARIPO (BW, GH, GM, KE, LR, LS, MW, MZ, NA, RW, SD, SL, SZ, TZ, UG, ZM, ZW), Eurasian (AM, AZ, BY, KG, KZ, RU, TJ, TM), European (AL, AT, BE, BG, CH, CY, CZ, DE, DK, EE, ES, FI, FR, GB, GR, HR, HU, IE, IS, IT, LT, LU,

LV, MC, MK, MT, NL, NO, PL, PT, RO, RS, SE, SI, SK, SM, TR), OAPI (BF, BJ, CF, CG, CI, CM, GA, GN, GQ, GW, ML, MR, NE, SN, TD, TG).

Declarations under Rule 4.17:

— as to applicant's entitlement to apply for and be granted a patent (Rule 4.17(ii))

Published:

— with international search report (Art. 21(3))

METHODS AND DEVICES FOR ABLATION OF TISSUE

CROSS-REFERENCE TO RELATED APPLICATIONS

[0001] The present application claims priority to U.S. Provisional Application Serial No. 61/486,206 filed May 13, 2011 and U.S. Provisional Application Number 61/485,621 filed May 13, 2011; and is a continuation-in-part of U.S. Application Number 13/107,720 filed May 13, 2011 and U.S. Application Number 13/107,759 filed May 13, 2011, the contents of each of which are incorporated herein by reference in their entirety.

FIELD OF THE INVENTION

[0002] This application is directed to methods and devices for ablating tissue. The procedures described herein may be performed in various regions of the body.

BACKGROUND

[0003] Procedures have involved the insertion of an electrode directly into tumors, with a ground electrode positioned elsewhere on a patient or utilizing a bipolar electrode array. RF is sent through the electrode to generate heat in the tumor in an attempt to kill the tumor. The problem with these procedures is that generating heat around an electrode within a tumor may cause the tumor to desiccate. This increases impedance within the tumor and reduces current flow such that there isn't enough current flow to heat through and destroy the entire tumor. Multiple electrodes have been inserted into a tumor and the electrodes have been multiplexed in an attempt to energize each electrode and generate heat, however, this has shown to be complex and not very effective.

[0004] Therefore, there remains a need for a more effective and efficient apparatus and method for ablating tissue in a minimally invasive manner.

SUMMARY

[0005] Various apparatus and methods for ablating tissue are described therein.

[0006] In certain variations, a method for ablating tissue may include one or more of the following steps. One or more electrodes, e.g., a first electrode and a second electrode, may be advanced to or near a target tissue in a subject. The electrodes may be energized

such that the electrodes create a plasma arc. The plasma arc generates heat which desiccates or ablates the target tissue.

[0007] An apparatus for ablating tissue may include an elongate instrument, e.g., a tube or rod. One or more electrodes, e.g., a first electrode and a second electrode, may be positioned in the elongate instrument, e.g., within channels, lumens or bores in the elongate instrument. The electrodes may be energized such that the electrodes create a plasma arc for generating heat to desiccate or ablate a target tissue.

[0008] In certain variations, various ablation methods and apparatus described herein may be guided to or near a target tissue or may access a target tissue or tumor by being advanced into and through an airway, through an opening or extra-anatomic opening created in an airway wall and to or near the target tissue or tumor beyond, at, outside or near the created opening. In other variations, the methods and apparatus described herein may be utilized to perform ablation procedures in various regions of the body utilizing various access techniques.

[0009] This application is also related to the following applications 61/485,621, filed on May 13, 2011; 13/107,720, filed on May 13, 2011; 13/107,759, filed on May 13, 2011; 61/563,369 filed November 23, 2011; 11/538,950 filed October 5, 2006; 12/939,968 filed November 4, 2010; 12/939,961 filed November 4, 2010; 12/939,956 filed November 4, 2010 and the patent application filed on the same day as the present application and titled "METHODS AND DEVICES FOR EXCISION OF TISSUE" and identified by attorney docket number BRON-N-E029.01-US; the contents of each of which are incorporated herein by reference in their entirety.

BRIEF DESCRIPTION OF THE DRAWINGS

[0010] Figure 1 illustrates a variation of an apparatus for ablating tissue.

[0011] Figure 2 illustrates a cross section of a variation of an elongate instrument of an apparatus for ablating tissue.

DETAILED DESCRIPTION

[0012] Various apparatus and methods for ablating tissue in a subject are described herein. Ablation may be performed on various types of tissues in various regions of the body, including, e.g., the lung. Various types of tissue may be ablated, including, e.g., diseased tissue or tumors. In certain variations, ablation may be performed

on blood vessels supplying blood to a tumor or other diseased or cancerous tissue. In certain variations, the procedures described herein may be performed through an opening, port or channel through an airway wall.

[0013] An apparatus for ablating tissue may include a heat source. The heat source may generate heat or heated steam to ablate a target tissue. A method for ablating tissue may include advancing a heat source to, near or in the proximity of a target tissue. The heat source may be left in position, next to or inside the target tissue where the heat source generates heat which desiccates, ablates, chars, vaporizes, and/or destroys the target tissue.

[0014] Various heat sources may be utilized to ablate tissue. In one variation, an apparatus for ablating tissue may include one or more electrodes. For example, an apparatus may include two electrodes. The distal ends of the electrodes may be spaced apart such that when the electrodes are energized, a plasma or a plasma arc may be formed across the gap or space between the electrodes, creating or generating heat or steam for ablating tissue. The electrodes may be energized to generate heat to desiccate or kill target tissue and/or the blood vessels supplying blood to such tissue. The electrodes may be positioned within or may extend from an elongate instrument, such as a tube, shaft or other device.

[0015] Figure 1 shows one variation of an apparatus for ablating tissue. The apparatus may include an elongate instrument 10, e.g., a rod, tube shaft or sheath. The elongate instrument 10 may include one or more lumens, bores or channels. For example, the elongate instrument 10 may include a first channel 12 and a second channel 13 for holding or enclosing one more electrodes (e.g., as shown in Figure 2). A first electrode 14 may be positioned in the first channel 12 and a second electrode 15 may be positioned in the second channel 13. The distal ends (or other portion) of the first and second electrodes 14, 15 may be spaced apart such that when the electrodes are energized an electrical arc, plasma (ionized gas), or a plasma arc 18 may be formed between the electrodes, across the gap or space between the electrodes, creating or generating heat for ablating, desiccating, and/or killing tissue. The heat or plasma may create temperatures ranging from about 1000 to about 6000 degrees C or about 1500 to about 2000 degrees C. A heated steam may be created between the electrodes and the heated steam may coil, flow, expand or spread out and ablate and kill the target tissue. The electrodes or wires may be connected to a generator (e.g., a radiofrequency (RF) generator) as a source of energy, e.g., high frequency energy or electricity. The plasma or plasma arc may be bright.

[0016] As shown in Figure 1, second electrode 15 may extend along a longitudinal

axis of the elongate instrument 10. Second electrode 15 may also include an arc 16 or turn, positioned at the distal end of the elongate instrument 10. The arc 16 may extend into a cap 17 or tip of the elongate instrument 10. The cap 17 or tip may be pointed or cone shaped and may include a conductive material. The energized second electrode 15 may transmit energy, e.g., heat or electrical current, through the conductive cap 17, to create a cutter or cutting element. For example, the energized conductive cap 17 may be used to cut or create an opening through an airway wall and/or to cut through parenchyma or lung tissue when the conductive cap 17 is advanced through an airway wall and/or into parenchyma or lung tissue to access a target tissue. Optionally, at least a portion of second electrode 15 may extend into a first channel 12 as well.

[0017] The elongate instrument 10 may be in the form of a tube or cylinder made from glass, quartz, ceramic, or similar material or any material having a high melting point, able to withstand high temperatures. The tube or cylinder may include one or more channels, lumens or bores. One or more electrodes or wires may be positioned in the channels, lumens or bores of the tube or cylinder or otherwise within the elongate instrument. The electrodes may include a variety of materials. For example, tungsten, molybdenum, carbon, stainless steel or any other materials having similar properties or materials having a high melting point. The electrodes may have a variety of shapes or configurations, e.g., having straight or curved portions. The electrodes may be positioned in a channel that is either open to air or sealed. If sealed, the channel could be in a vacuum or filled with an inert gas. Alternatively, the channel may be melted around the electrodes, leaving no space at all. In certain variations, an elongate instrument, a tube or cylinder may encapsulate the electrodes and trap any released vapor or gas emitted from the electrodes, e.g., tungsten vapor, to prevent or reduce the emission of vapor or gas into a patient's body. In certain variations, an elongate instrument may be with or without channels.

[0018] The apparatus or electrodes for ablating tissue may be monopolar or bipolar. For example, in certain variations, a ground plate or ground electrode may be utilized. The electrodes or wires may be affixed or melted to the elongate instrument to prevent the electrode wires from moving within the elongate instrument. For example, a laser welder may be used to administer heat through a glass tube to melt the electrodes or wires to the glass tube.

[0019] In certain variations, an apparatus for ablating tissue may include one or more

electrodes or conductive wires or elements for generating heat between the electrodes or wires, and/or creating plasma or a plasma arc between the electrodes, to heat and ablate tissue. The electrodes or wires may or may not be encapsulated or positioned within an elongate instrument, e.g., a tube or cylinder. In certain variations, the electrodes may extend outside of an elongate instrument to form plasma or otherwise generate heat outside of the elongate instrument. Optionally, the ends of electrodes utilized herein may be melted or shaped to provide an anode or cathode configuration. For this, each tip must be electrified and there may be no grounding plate. The grounding plate could be utilized for cutting a tract or path if the conductive wire or element most distal is one electrode and the grounding plate is the other electrode.

[0020] In one variation, a method for ablating a target tissue, e.g., a tumor, (lung or other), tissue surrounding a tumor, or blood vessels supplying blood to a tumor, may include one or more of the following steps. The elongate instrument may be navigated within the subject. For example, in the lung, the elongate instrument may be advanced within a lumen of an airway in the lung. The elongate instrument may be advanced to, near or in proximity to the target tissue. One or more electrodes positioned within the elongate instrument may be energized and may transmit energy, e.g., heat or electrical current, through a conductive distal portion or cap of the elongate instrument, providing a cutting or piercing member or tip for cutting or piercing through tissue. For example, for procedures in the lung, the energized distal portion or cap may be advanced through an airway wall, creating an opening or port through the airway wall and/or through or into the parenchyma or lung tissue. Alternately, a non-energy based tunneling device, such as a blunt dissection probe navigation and access system as described below and in US. Pat. Applications: US. Pat. Applications: 61/485,621, filed on May 13, 2011; 13/107,720, filed on May 13, 2011; 13/107,759, filed on May 13, 2011; and 61/563,369 filed November 23, 2011, the contents of each of which are incorporated herein by reference in their entirety, may be employed to create the opening in the airway wall and/or the tunnel to access the target tissue.

[0021] The elongate instrument and electrodes positioned therein may be advanced next to or near the target tissue or tumor or into the target tissue or tumor. The electrodes are energized (e.g., an electrical current flows through the electrode) such that a plasma or plasma arc is created between the electrodes. The electrodes and/or the plasma may generate heat to desiccate and kill the target tissue, e.g., the tumor or the blood vessels surrounding a target tissue or tumor, thereby cutting off the blood supply to the tumor. Ablation may be performed around the tumor to cut off its blood supply, e.g., in a couple of

places around the tumor or all around the tumor. A crater may be ablated around the target tissue or tumor to kill the target tissue. A heated steam may be created between the electrodes and the heated steam may coil or spread out and ablate and kill the target tissue. The elongate instrument and energized electrodes are allowed to remain in place within or near the target tissue for a certain time interval or until ablation of the target tissue is achieved. Indeed, the elongate instrument and electrodes may be positioned in or near the target tissue for an amount of time sufficient to allow heat to radiate from the electrodes and/or plasma arc, and through the tissue to desiccate, ablate vaporize and/or kill the target tissue. Radiation of heat through the target tissue may improve or increase as the tissue desiccates.

[0022] In one variation, the plasma arc may remain activated and may deliver heat to the target tissue for about 0 to 5 minutes. In certain variations, the plasma arc between the electrodes may generate heat until the electrodes are burned off and the plasma arc dissipates. The apparatus may then be disposed. In certain variations, the electricity provided to the electrodes may be pulsed to avoid burning off the electrodes or to cool the electrodes such that the electrodes may last for a longer duration. In certain variations a fluid or gas may be circulated, e.g., on, in or around the elongate instrument, to provide active cooling of the electrodes.

[0023] Various imaging technologies (e.g. MRI, CT, PET, fluoroscopy, etc) may be utilized to monitor the shrinkage of a tumor or target tissue as the tumor or other target tissue or the blood vessels supplying blood to the tumor are ablated using the apparatus and/or methods described herein. Alternatively, the light generated by the electrodes and/or the plasma or plasma arc may provide feedback, e.g. rapid feedback, regarding the location of the apparatus or the electrodes and plasma arc in the patient, e.g., when using visualization technology. The light may also be visible through the patient's skin, e.g., through the chest wall when the apparatus is positioned in the lung, allowing for localization of the apparatus by transillumination or direct visualization feedback.

[0024] In certain variations, the apparatus and methods described herein may be utilized in a region of the patient's body where one or more or multiple tumors are present. For example, tumors present in an upper lobe, lower lobe, and/or right or left side of a lung may be ablated using the apparatus and methods described herein. The apparatus may be advanced into tissue of a lung via an opening created through an airway wall, where the apparatus may be used to ablate multiple tumors and/or their corresponding blood vessels

while the apparatus is positioned within the lung. The tumors or nodules may each be ablated, cooked or killed, e.g., in seconds to a minute or minutes, allowing multiple tumors or nodules to be ablated in a relatively short period of time. The apparatus and methods described herein may be used for performing ablation in various regions of a patient's body, e.g., the lung, liver, and/or brain.

[0025] The energized electrodes or the plasma may create a vapor, e.g., a tungsten vapor when tungsten electrodes are utilized. Various devices for encapsulating the vapor such that the vapor is not released into a patient's body are provided. As described supra, the electrodes and plasma may be encapsulated within an elongate instrument, e.g., a glass tube (quartz glass or regular glass), which has a space for capturing the tungsten vapor. The glass tube may have dual channels in which electrodes may be positioned. The vapor may be captured within a channel and/or in a separate space or pocket within the elongate instrument or glass tube.

[0026] In one variation, a glass tube is provided for encapsulating one or more electrodes or microelectrodes. The glass tube may have a diameter ranging from about 1.0 to about 2.0 millimeters, e.g., about 1.4 millimeters. The glass tube includes one or more channels or bores having a diameter similar in size or slightly larger than the size of the electrode or wire (e.g., tungsten) to be positioned therein and an outside diameter having a size sufficient to allow the apparatus to be fed down the working channel of common endoscopes or bronchoscopes.

[0027] In one variation, a method for creating a dual channel glass (or similar material) tube for encapsulating energized tungsten electrodes and the resulting tungsten vapor includes one or more of the following steps. A glass tube is heated such that the glass may melt around one or more tungsten electrodes. A balloon (e.g., a nylon balloon) may be positioned between the electrodes, and may remain in between the electrodes as the glass is melted around the electrodes and the balloon, creating a bubble between the electrodes. Once the melting is complete and the tube having tungsten electrodes secured therein is complete, the electrodes may be energized or activated, burning away the balloon which leaves a space between the electrodes that was previously occupied by the balloon. The energized electrodes create a plasma or plasma arc across that space. The glass tube surrounds, encapsulates or encloses the electrodes and the plasma arc and may capture any released gasses or vapor, e.g., tungsten vapor. Tubes for encapsulated other types of electrodes and their resulting vapor may also be created in accordance with the above manner.

[0028] Electrodes encapsulated or enclosed in a glass tube or other elongate instrument may not oxidize or may experience minimal oxidation, allowing the electrodes to remain energized and/or burn for an extended amount of time, avoiding a rapid burn off. The encapsulated electrodes have strong conduction and generate heat sufficient for ablating tissue. Over time, the heat may melt the tube, and once the tube is melted around and/or between the electrodes to a point where the plasma arc and/or electrical arc and/or heat or heated steam is no longer generated, the apparatus may be disposed. In other variations, an elongate instrument or glass tube may be reusable where the electrodes may be replaced after use with new electrodes.

[0029] In another variation, a tungsten wire may be bonded to molybdenum either mechanically or by laser welding and a glass tube may be melted and/or bonded to the molybdenum for a stronger or improved bonding or connection between the glass and the electrodes. During melting of the glass, air/inert gas can be blown into the center of the glass tube or the formed pocket may later be filled with argon or other material. The tungsten can also be released, marking the area with a radio-opaque and MRI visible material.

[0030] In any of the above variations, a nose cone or cap of various configurations or pointed tip may be fused or attached to the distal end of the elongate instrument over an electrode. This provides a cover or distal end to the apparatus or elongate instrument, which may have a variety of shapes or configurations depending on the particular use. The cap may conduct energy (e.g., electricity or heat) and act as a piercing member or cutter. Alternatively or in addition, the cap may have sharpened or pointed end to allow for mechanical piercing or cutting.

[0031] In certain variations, glass utilized in any of the apparatus described herein may be metalized by inserting metal particles in the glass. Optionally, a sheath (e.g., a metal sheath) may be positioned around a glass tube, which provides a differing profile for temperature or delivery. For example, a thick metal may maintain a high temperature for a longer duration.

[0032] In any of the above variations, a thermocouple or temperature gauge may be positioned in an elongate instrument, e.g., in a channel or bore within the elongate instrument. The thermocouple or temperature gauge may measure the temperature of the tissue and provide feedback regarding whether or not the ablation treatment is completed or not. In certain variations, a table may be utilized which provides parameters for how long tissue should be heated based on the size of a tumor or target tissue mass and/or distance of

the device from the tumor. An MRI signature may also be used to determine the temperature of the tissue as it is heated.

[0033] In certain variations, a reflector may be utilized to direct heat in a certain direction. For example, a metalized reflector may be positioned on one side of the apparatus such that all of the heat is directed to the opposite side of the apparatus. In certain variations, the elongate instrument may be parabolic and/or radiopaque to facilitate proper orientation of the elongate instrument and the electrodes during use.

[0034] The various ablating apparatus described herein, may be guided or navigated to the target tissue or tumor and/or the target tissue or tumor may be located using one or more imaging technologies, such as, x-ray, CT, MRI, fluoroscopy

[0035] In certain variations, various ablation methods and apparatus described herein may be guided to or may access a target tissue or tumor by being advanced into and through an airway, through an opening or extra anatomic opening created in an airway wall and to the target tissue or tumor beyond, at or near the created opening, where the target tissue is located in the lung, outside the lung or in another area of the body.

[0036] In certain variations, methods or platforms for accessing target tissues (e.g., diseased tissue, tumors, parenchyma or other tissues or structures) in a lung or other area of the body, through an opening, extra-anatomic opening or port through the airway wall may be utilized to access a target tissue with any of the ablation apparatus or methods described herein. The target tissue may be located outside of the airway in which the opening is created or beyond the airway wall, e.g., in the parenchyma of the lung.

[0037] Access to the central airways may be achieved by using a standard bronchoscope or other scope or elongate instrument. A target site or point in a larger airway or central airway or smaller airway may be determined or selected, which may allow a straight or substantially straight tunnel, channel or path to be created leading directly to the target tissue. Once the target site on the airway wall is located an opening is created through the airway wall at the target site on the wall by advancing a piercing member or needle to the target site and through the airway wall at the target site. The created opening may be dilated with a balloon catheter or other expandable device.

[0038] Once the opening has been dilated, a sheath or other elongate instrument may be fed

through the hole or opening and into the lung tissue. The sheath may contain a dissecting catheter and the tip of the dissecting catheter may be sharp to tunnel through tissue or it may be blunt or rounded to allow it to tunnel without perforating blood vessels or other structures. The tip may tunnel or advance through the lung tissue in a substantially straight path where turns are minimized or eliminated. Once the sheath and dissecting catheter are fed to or near the target tissue or tumor, the dissecting catheter may be removed, with the sheath remaining in position to be used to access the target tissue or tumor and to deliver any of the various ablation apparatus described herein to or near the target tissue or tumor to perform ablation. Various imaging techniques may be utilized to guide the bronchoscope and piercing member and to guide the sheath, dissecting catheter, and/or ablation apparatus through the airway to the target site on the airway wall and/or to the target tissue for removal. Imaging techniques may include fluoroscopy, computed tomography, positron emission technology, magnetic resonance imaging, or ultrasound.

[0039] In certain variations, the multiple steps of the above procedure, i.e., creating an opening in the airway wall, going through the opening to dilate it and/or extending an instrument or apparatus through the opening to access a target tissue for ablation, may be performed with a single device or with more than one device. For example, a multi purpose device, e.g., a variation of an ablation apparatus as described herein, may create an opening with an energized piercing tip, and be advanced through the opening to dilate the opening and/or access a target tissue to perform ablation. Alternatively, the above procedure may be performed with more than one device, e.g., utilizing separate devices to create an opening, to dilate the opening and/or access a target tissue via the created opening with an ablation apparatus (as described herein) to ablate tissue.

[0040] The various ablation methods or apparatus described herein may also be guided or navigated to or may access a target tissue or tumor using any of the various devices or methods for creating an extra-anatomic opening in an airway wall and/or accessing tissue through an extra-anatomic opening through an airway wall as described in the following: US. Pat. Applications: 61/485,621, filed on May 13, 2011; 13/107,720, filed on May 13, 2011; 13/107,759, filed on May 13, 2011; 61/563,369 filed November 23, 2011; 11/538,950 filed October 5, 2006; 12/939,968 filed November 4, 2010; 12/939,961 filed November 4, 2010; and 12/939,956 filed November 4, 2010; the contents of each of which are incorporated herein by reference in their entirety.

[0041] In certain variations, any of the imaging technologies described above may be

incorporated into an ablation apparatus or may be performed through an elongate instrument of the apparatus such that navigation or tracking, tissue cutting, and tissue ablation may be performed by a single device or, alternatively, by multiple devices provided via the elongate instrument or other instrument.

[0042] Any of the variations described herein may be used for cutting or ablating tissue in any region of the body, e.g., the lung, liver, or brain via various access points, utilizing minimally invasive or open surgery techniques.

[0043] All publications, patent applications, patents, and other references mentioned herein are incorporated by reference in their entirety. To the extent there is a conflict in a meaning of a term, or otherwise, the present application will control. Although variations of the foregoing invention have been described in some detail by way of illustration and example for purposes of clarity of understanding, it will be readily apparent to those of ordinary skill in the art in light of the teachings of this invention that certain changes and modifications may be made thereto without departing from the spirit or scope of the appended claims. It is also contemplated that combinations of the above described embodiments/variations or combinations of the specific aspects of the above described embodiments/variations are within the scope of this disclosure.

[0044] Each of the individual variations described and illustrated herein has discrete components and features which may be readily separated from or combined with the features of any of the other variations. Modifications may be made to adapt a particular situation, material, composition of matter, process, process act(s) or step(s) to the objective(s), spirit or scope of the present invention.

[0045] Methods recited herein may be carried out in any order of the recited events which is logically possible, as well as the recited order of events. Furthermore, where a range of values is provided, every intervening value between the upper and lower limit of that range and any other stated or intervening value in that stated range is encompassed within the invention. Also, any optional feature of the inventive variations described may be set forth and claimed independently, or in combination with any one or more of the features described herein.

[0046] All existing subject matter mentioned herein (e.g., publications, patents, patent applications and hardware) is incorporated by reference herein in its entirety except insofar as the subject matter may conflict with that of the present invention (in which case what is present herein shall prevail). The referenced items are provided solely for their disclosure prior to the filing date of the present application. Nothing herein is to be construed as an

admission that the present invention is not entitled to antedate such material by virtue of prior invention.

[0047] Reference to a singular item, includes the possibility that there are plural of the same items present. More specifically, as used herein and in the appended claims, the singular forms “a,” “an,” “said” and “the” include plural referents unless the context clearly dictates otherwise. It is further noted that the claims may be drafted to exclude any optional element. As such, this statement is intended to serve as antecedent basis for use of such exclusive terminology as “solely,” “only” and the like in connection with the recitation of claim elements, or use of a “negative” limitation. Unless defined otherwise, all technical and scientific terms used herein have the same meaning as commonly understood by one of ordinary skill in the art to which this invention belongs.

[0048] This disclosure is not intended to be limited to the scope of the particular forms set forth, but is intended to cover alternatives, modifications, and equivalents of the variations described herein. Further, the scope of the disclosure fully encompasses other variations that may become obvious to those skilled in the art in view of this disclosure. The scope of the present invention is limited only by the appended claims.

CLAIMS

We claim:

1. An apparatus for ablating tissue comprising:
an elongate instrument;
a first electrode and a second electrode positioned in the elongate instrument, wherein the electrodes are configured to create a plasma arc for generating heat.
2. The apparatus of claim 1, wherein the elongate instrument comprises a tube having a first channel and a second channel, wherein at least a portion of the first electrode is positioned within the first channel and at least a portion of the second electrode is positioned in the second channel.
3. The apparatus of claim 1 or 2, wherein a space is provided between the electrode and a plasma arc is created in the space.
4. The apparatus as claimed in any one of the preceding claims, wherein the elongate instrument is configured to encapsulate vapor released from the electrodes.
5. The apparatus as claimed in any one of the preceding claims, wherein the electrodes are configured to burn off after a period of time.
6. The apparatus as claimed in any one of the preceding claims, wherein the electrodes are made from tungsten or molybdenum.
7. The apparatus as claimed in any one of the preceding claims, wherein the elongate instrument comprises a conductive cap positioned at the distal end of the elongate instrument, wherein a portion of an electrode is positioned within the cap, such that the cap functions as an electrical cutter.
8. The apparatus as claimed in any one of the preceding claims, further comprising an imaging mechanism for guiding or tracking the apparatus.
9. The apparatus as claimed in any one of the preceding claims, wherein light generated

by the plasma arc provides feedback regarding the localization of the plasma arc in the patient using.

10. The apparatus as claimed in any one of the preceding claims, wherein the heat or plasma may create temperatures ranging from about 1000 to about 6000 degrees C.

11. The apparatus as claimed in any one of the preceding claims, wherein the elongate instrument is configured to be advanced through an opening through an airway wall to position the plasma arc next to a target tissue or tumor in the lung.

12. A method for ablating tissue, the method comprising:

advancing a first electrode and a second electrode to or near a target tissue in a subject; and

energizing the electrodes such that the electrodes create a plasma arc, wherein the plasma arc generates heat which desiccates the target tissue.

13. The method of claim 12, wherein the plasma arc is positioned next to a tumor such that the heat desiccates or ablates blood vessels supplying blood to the tumor.

14. The method of claim 12, wherein the plasma arc generates a heated steam which desiccates and ablates the target tissue.

15. The method of claim 12, wherein the first and second electrodes are positioned within an elongate instrument, wherein the elongate instrument comprises an electrical cutting distal tip for cutting tissue to advance the electrodes to the target tissue.

16. The method of claim 12, wherein light generated by the plasma arc provides feedback regarding the localization of the plasma arc in the patient.

17. The method of claim 16, wherein the light is visible through the subject's skin, e.g., allowing for localization of the apparatus.

18. The method of claim 12, further comprising, providing imaging to monitor target tissue shrinkage.

19. The method of claim 12, wherein the first and second electrodes are advanced through an opening through an airway wall to position the plasma arc next to a target tissue or tumor in the lung.

20. The method of claim 12, wherein the heat or plasma may create temperatures ranging from about 1000 to about 6000 degrees C.

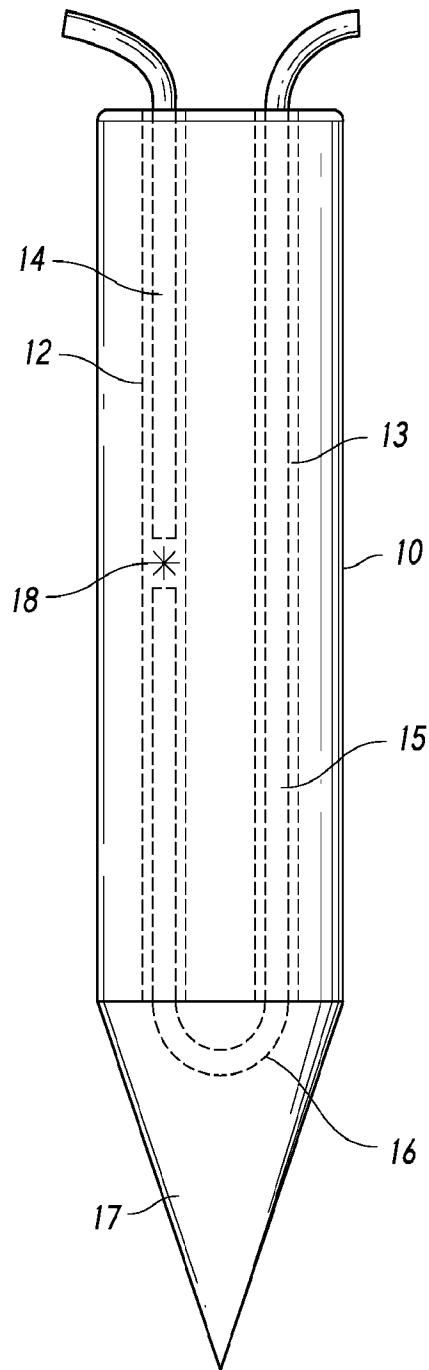

FIG. 1

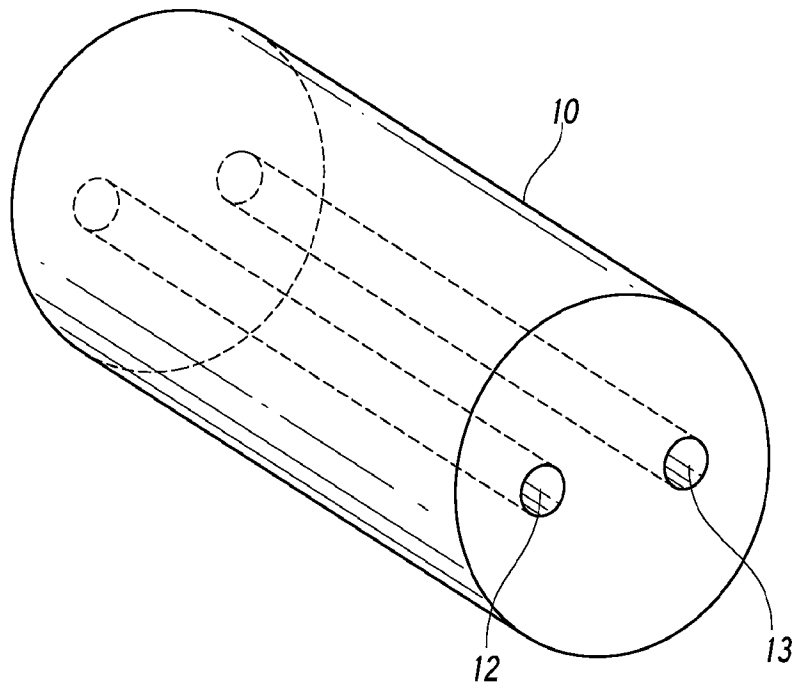

FIG. 2

INTERNATIONAL SEARCH REPORT

International application No.
PCT/US2012/037551

A. CLASSIFICATION OF SUBJECT MATTER
 IPC(8) - A61B 18/18 (2012.01)
 USPC - 606/48
 According to International Patent Classification (IPC) or to both national classification and IPC

B. FIELDS SEARCHED
 Minimum documentation searched (classification system followed by classification symbols)
 IPC(8) - A61B 18/00, 18/18 (2012.01)
 USPC - 604/22, 23; 606/46, 48

Documentation searched other than minimum documentation to the extent that such documents are included in the fields searched

Electronic data base consulted during the international search (name of data base and, where practicable, search terms used)
 Patbase, Google Patents

C. DOCUMENTS CONSIDERED TO BE RELEVANT

Category*	Citation of document, with indication, where appropriate, of the relevant passages	Relevant to claim No.
X ---	US 5,919,191 A (LENNOX et al) 06 July 1999 (06.07.1999) entire document	1-3, 12-14, 20
Y		----- 15-19
Y	US 6,749,606 B2 (KEAST et al) 15 June 2004 (15.06.2004) entire document	15, 19
Y	US 2008/0039715 A1 (WILSON et al) 14 February 2008 (14.02.2008) entire document	16-17
Y	US 7,483,755 B2 (INGLE et al) 27 January 2009 (27.01.2009) entire document	18
A	US 5,843,079 A (SUSLOV) 01 December 1998 (01.12.1998) entire document	1-3, 12-20
A	US 4,855,563 A (BERESNEV et al) 08 August 1989 (08.08.1989) entire document	1-3, 12-20

Further documents are listed in the continuation of Box C.

* Special categories of cited documents:	"T" later document published after the international filing date or priority date and not in conflict with the application but cited to understand the principle or theory underlying the invention
"A" document defining the general state of the art which is not considered to be of particular relevance	"X" document of particular relevance; the claimed invention cannot be considered novel or cannot be considered to involve an inventive step when the document is taken alone
"E" earlier application or patent but published on or after the international filing date	"Y" document of particular relevance; the claimed invention cannot be considered to involve an inventive step when the document is combined with one or more other such documents, such combination being obvious to a person skilled in the art
"L" document which may throw doubts on priority claim(s) or which is cited to establish the publication date of another citation or other special reason (as specified)	"&" document member of the same patent family
"O" document referring to an oral disclosure, use, exhibition or other means	
"P" document published prior to the international filing date but later than the priority date claimed	

Date of the actual completion of the international search 09 August 2012	Date of mailing of the international search report 24 AUG 2012
---	--

Name and mailing address of the ISA/US Mail Stop PCT, Attn: ISA/US, Commissioner for Patents P.O. Box 1450, Alexandria, Virginia 22313-1450 Facsimile No. 571-273-3201	Authorized officer: Blaine R. Copenheaver PCT Helpdesk: 571-272-4300 PCT OSP: 571-272-7774
---	---

INTERNATIONAL SEARCH REPORT

International application No.

PCT/US2012/037551

Box No. II Observations where certain claims were found unsearchable (Continuation of item 2 of first sheet)

This international search report has not been established in respect of certain claims under Article 17(2)(a) for the following reasons:

1. Claims Nos.:
because they relate to subject matter not required to be searched by this Authority, namely:

2. Claims Nos.:
because they relate to parts of the international application that do not comply with the prescribed requirements to such an extent that no meaningful international search can be carried out, specifically:

3. Claims Nos.: 4-11
because they are dependent claims and are not drafted in accordance with the second and third sentences of Rule 6.4(a).

Box No. III Observations where unity of invention is lacking (Continuation of item 3 of first sheet)

This International Searching Authority found multiple inventions in this international application, as follows:

1. As all required additional search fees were timely paid by the applicant, this international search report covers all searchable claims.
2. As all searchable claims could be searched without effort justifying additional fees, this Authority did not invite payment of additional fees.
3. As only some of the required additional search fees were timely paid by the applicant, this international search report covers only those claims for which fees were paid, specifically claims Nos.:

4. No required additional search fees were timely paid by the applicant. Consequently, this international search report is restricted to the invention first mentioned in the claims; it is covered by claims Nos.:

Remark on Protest

- The additional search fees were accompanied by the applicant's protest and, where applicable, the payment of a protest fee.
- The additional search fees were accompanied by the applicant's protest but the applicable protest fee was not paid within the time limit specified in the invitation.
- No protest accompanied the payment of additional search fees.